

LICENSE AGREEMENT

THIS LICENSE AGREEMENT ("Agreement" or "License Agreement"), dated as of the latter of the signature dates below (the "Effective Date"), is entered into by MT. DIABLO UNIFIED SCHOOL DISTRICT, a California public school district having a mailing address 1936 Carlotta Drive, Concord CA 94519 (hereinafter referred to as "Licensor" or "District") and T-Mobile West Corporation, a Delaware corporation (hereinafter referred to as "Licensee"), having a mailing address of 12920 SE 38th Street, Bellevue, WA 98006, Attn: PCS Lease Administrator, with a copy to: Attn: Legal Dept..

RECITALS

This License Agreement is entered into based on the following facts, circumstances and understandings:

A. Licensor is a California public school district which owns certain real property commonly known as Mount Diablo Unified School District, 1936 Carlotta Drive, Concord, CA 94519 ("Property"). Licensee desires to use a portion of Licensor's Property for a ground area space of approximately six hundred (600) square feet and communications fixtures, more particularly described in Exhibit 1 ("the Premises"), with any necessary easements over other portions of Licensor's Property and/or shared use of Licensor's easements over other real property necessary for Licensee's access to the Premises, as described in Exhibit 1.

B. Licensee is a communications carrier that desires to construct and operate a wireless communications site at the Premises as part of its communications network.

C. Licensor is willing to license the Premises to Licensee for Licensee's proposed use subject to the terms and conditions of this License Agreement.

The parties, in exchange for good and valuable consideration which is hereby acknowledged, agree as follows:

AGREEMENT

1. **GRANT OF LICENSE.** Licensor hereby grants a license to Licensee to use the Premises for Licensee's proposed use, subject to the following terms and conditions ("**License**"). Except as set forth in Recital A above, the term "easement" in this Agreement shall not confer any greater right than a license as described herein. This License shall be deemed a license coupled with an interest, the interest being the equipment described herein. Notwithstanding the above, Licensor agrees that it will not terminate this License and the rights contained herein, unless as otherwise set forth herein below or as required by law.

2. **PERMITTED USE.** Licensee may use the Premises for the transmission and reception of communications signals and the installation, construction, maintenance, operation, repair, replacement and upgrade of its communications fixtures and related equipment, cables, accessories and improvements, which may include a suitable support structure, associated antennas, equipment shelters or cabinets and fencing and any other items reasonably necessary to the successful and secure use of the Premises (collectively, the "**Communication Facility**"), as set forth in Exhibit 1. Pursuant to the provisions set forth in paragraph 5(c) below, Licensee has the right to test and survey the Property upon advance notice to, and written approval from,

District; Licensee further has the right to add, modify and/or replace equipment in order to be in compliance with any current or future federal, state or local mandated application, including, but not limited to, emergency 911 communication services, at no additional cost to Licensee or Licensor (collectively, the "**Permitted Use**"). Licensor and Licensee agree that any portion of the Communication Facility conceptually described on **Exhibit 1** will not be deemed to limit Licensee's Permitted Use though it will limit Licensee to the Premises and to uses related to Licensee's use of the Premises as a Communication Facility. If **Exhibit 1** includes drawings of the initial installation of the Communication Facility, Licensor's execution of this Agreement will signify Licensor's approval of **Exhibit 1**. Licensee has the right to install and operate transmission cables from the equipment shelter or cabinet to the antennas as set forth in Exhibit 1, electric lines from the main feed to the equipment shelter or cabinet and communication lines from the main entry point to the equipment shelter or cabinet, and to make improvements, alterations, upgrades or additions appropriate for Licensee's use ("**Licensee Changes**") both set forth in Exhibit 1, or if not set forth, after receiving District's written approval. Licensee shall construct a fence around the Premises and shall undertake all appropriate means to secure the Premises. Licensee agrees to comply with all applicable governmental laws, rules, statutes and regulations, relating to its use of the Communication Facility on the Premises. Upon providing prior written notice to Licensor, Licensee has the right to modify, supplement, replace, upgrade, expand the equipment, increase the number of antennas or relocate the Communication Facility within the Premises at any time during the term of this Agreement. Licensee will be allowed to make such alterations to the Property in order to accomplish Licensee's Changes, or to insure that Licensee's Communication Facility complies with all applicable federal, state or local laws, rules or regulations. However, any modifications which exceed the dimensions of the Premises or materially alter the exterior appearance of the Communication Facility shall require Licensor's prior written consent. In the event Licensee desires to modify or upgrade the Communication Facility, and Licensee requires an additional portion of the Property (the "**Additional Premises**") for such modification or upgrade, Licensor agrees to consider expanding this License Agreement to include the Additional Premises, as may be acceptable to Licensor, upon the same terms and conditions set forth herein, except that the Rent shall increase, in conjunction with the use of the Additional Premises by a reasonable amount consistent with rental rates then charged for comparable portions of real property being in the same area, or upon any different terms and conditions as may be agreed upon by the parties. Licensor shall not be required to grant use of Additional Premises. In the event that Licensor grants use of Additional Premises, Licensor agrees to take such actions and enter into and deliver to Licensee such documents as Licensee reasonably requests in order to effect and memorialize the License of the Additional Premises to Licensee. Licensee agrees not to include signage on the Premises except for emergency signage shown in Exhibit 1 and that otherwise may be required by law.

3. **TERM.**

(a) The initial License term will be five (5) years ("**Initial Term**"), commencing upon Licensee's start of construction or October 1, 2010, whichever first occurs. The Initial Term will terminate on the fifth (5th) annual anniversary of the Effective Date.

(b) This Agreement will automatically renew for four (4) additional five (5) year term(s) (each five (5) year term shall be defined as the "**Extension Term**"), upon the same terms and conditions, but subject to the provisions set forth in paragraph 4(c) below, unless the Licensee notifies the Licensor in writing of Licensee's intention not to renew this Agreement at least sixty (60) days prior to the expiration of the existing Term.

(c) If Licensee remains in possession of the Premises after the termination or expiration of this Agreement then Licensee will be deemed to be occupying the Premises on a month to month basis (the "**Holdover Term**"), subject to the terms and conditions of this Agreement.

(d) The Initial Term, the Extension Term and the Holdover Term are collectively referred to as the Term ("**Term**").

4. **CONSIDERATION.** In consideration for District granting Licensee the License as set forth in this Agreement:

(a) Licensee shall pay District a one-time payment in the amount of Five Thousand and No/100 Dollars (\$5,000.00); provided that Licensee completes its testing as outlined in Section 5 below and Licensee elects to commence construction. This payment shall represent a signing fee and is a one-time only payment, due at the time that Licensee completes its testing as outlined in Section 5 below and Licensee elects to commence construction.

(b) Commencing on the first day of the month following the date that Licensee commences construction, or October 1, 2010, whichever occurs earlier (the "**Rent Commencement Date**"), Licensee will pay the Licensor a monthly rental payment of Three Thousand and No/100 Dollars (\$3,000) ("**Rent**"), at the address set forth above, on or before the fifth (5th) day of each calendar month in advance. In partial months occurring after the Rent Commencement Date, Rent will be prorated. The initial Rent payment will be forwarded by Licensee to Licensor within thirty (30) days after the Rent Commencement Date.

(c) Starting at the end of first year after the Rent Commencement Date, and for each year following thereafter, the monthly Rent will increase by three percent (3 %) over the Rent paid during the previous year.

5. **CONDITION PRECEDENT: APPROVALS.**

(a) Licensor agrees that Licensee's ability to use the Premises is contingent upon the suitability of the Premises for Licensee's Permitted Use and Licensee's ability to obtain and maintain all governmental licenses, permits, approvals or other relief required of or deemed necessary or appropriate by Licensee for its use of the Premises, including without limitation applications for zoning variances, zoning ordinances, amendments, special use permits, and construction permits (collectively, the "**Government Approvals**"). Licensor authorizes Licensee to prepare, execute and file all required applications to obtain Government Approvals for Licensee's Permitted Use under this Agreement and agrees to reasonably assist Licensee with such applications and with obtaining and maintaining the Government Approvals. In addition, Licensee shall have the right to initiate the ordering and/or scheduling of necessary utilities as set forth in Exhibit 1.

(b) Licensee has the right to obtain a title report or commitment for a leasehold title policy from a title insurance company of its choice and to have the Property surveyed by a surveyor of Licensee's choice within forty five (45) days after execution of this Agreement. If the survey results show that the condition of the Premises is unsatisfactory for the permitted use, Licensee will have the right to terminate this Agreement upon notice to District.

(c) Licensee may also perform and obtain, at Licensee's sole cost and expense, soil borings, percolation tests, engineering procedures, environmental investigation or other tests or reports on, over, and under the Premises, necessary to determine if the Licensee's use of the Premises will be compatible with Licensee's engineering specifications, system, design, operations or Government Approvals. Licensee shall provide District with twenty four (24) hour advance written notice of any testing it plans to undertake pursuant to this section and will tender true and correct copies of any and all such borings, tests, investigations or reports to District. At completion of testing, Licensee shall immediately return the Premises to the condition in which it existed prior to the Licensee undertaking any testing. If Licensee does not immediately return Premises to the condition which existed prior to Licensee undertaking its testing, District may repair the damage and Licensee shall reimburse District for all of its costs. Licensee shall conduct its tests and construction in such a manner that they shall not interfere with the school

programs or activities or jeopardize the safety of Licensor's students, employees and invitees, licensees, and agents of Licensor.

6. TERMINATION. This Agreement may be terminated, without penalty or further liability, as follows:

(a) by Licensor for non-payment of Rent if such Rent remains unpaid for more than twenty (20) days after Licensee's receipt of written notice from Licensor of such failure to pay;

(b) by either party on thirty (30) days written notice, if the other party remains in default under Paragraph 16 Default and Right to Cure of this Agreement after the applicable cure periods; if Licensee defaults, Licensee shall immediately return the Premises to the condition in which it existed prior to the execution of the Agreement, reasonable wear and tear and loss beyond Licensee's control excepted, unless District agrees in writing that the Premises can remain in its present condition. If Licensor defaults, and Licensee elects to terminate this Agreement, Licensee shall remove the Communication Facility and return the Premises to the condition in which it existed prior to the execution of this Agreement.

(c) by Licensee upon written notice to Licensor, if Licensee is unable to obtain, or maintain, any required approval(s) or the issuance of a license or permit by any agency, board, court or other governmental authority necessary for the construction or operation of the Communication Facility as now or hereafter intended by Licensee; or if Licensee determines in its sole discretion that the cost of obtaining or retaining the same is commercially unreasonable; Licensee shall immediately return the Premises to the condition in which it existed prior to the Commencement Date, reasonable wear and tear and loss beyond Licensee's control excepted, unless District agrees in writing that the Premises remain in its present condition;

(d) by Licensee upon written notice to Licensor for any reason, at any time prior to commencement of construction by Licensee;

(e) by Licensee upon sixty (60) days prior written notice to Licensor for any reason, so long as Licensee pays Licensor a termination fee equal to three (3) months Rent, at the then current rate, provided, however, that no such termination fee will be payable on account of the termination of this Agreement by Licensee under any one or more of Paragraphs 5(b) Approvals, 6(b) Termination, 6(c) Termination, 6(d) Termination, 8 Interference, 11(d) Environmental, 20 Condemnation or 21 Casualty of this Agreement. Licensee shall return the Premises to the condition in which it existed prior to the Commencement Date, reasonable wear and tear and loss beyond Licensee's control excepted, unless District agrees in writing that the Premises remain in its present condition; or

(f) by District, after the expiration of the first Extension Term, if any, upon three hundred sixty-five (365) days advance written notice to Licensee.

(g) In addition to termination rights as provided in Section 6 of this Agreement, this Agreement may be terminated immediately by Licensor without any penalty or further liability by or of Licensor in the event there is a termination made pursuant to an official non-appealable order of a county, state or national governmental health agency having proper jurisdiction, including all state agencies with any oversight over District as a California public school district, including but not limited to, CDE, DSA, DTSC, etc., or by any court of competent jurisdiction, that an electromagnetic field associated with facilities like those operated by Licensee constitute material health risks. Any termination of the Agreement as provided under the provisions of this Section 6(g) shall relieve both parties of any further obligations under this Agreement (except provisions which indicate they survive termination), although Licensee shall continue to be responsible for any breach of any obligations which occurred prior to the date of such termination. Upon such termination pursuant to this section 6(g), Licensee shall as soon as reasonably practicable thereafter return the Premises to the condition in which it existed prior to

the Commencement Date, reasonable wear and tear and loss beyond Licensee's control excepted, unless District agrees in writing that the Premises can remain in its present condition.

(h) In addition, at the termination of this Agreement, and except for circumstances associated with Licensor's default, Licensee shall, at Licensee's sole cost and expense, return the Premises to the condition in which it existed prior to the execution of the Agreement, reasonable wear and tear and loss beyond Licensee's control excepted. If Licensee does not return the Premises to the condition which existed prior to Licensee's control, District may return the Premises to such condition and Licensee shall reimburse District for all of its costs.

7. **INSURANCE.** Licensee will carry during the Term, at its own cost and expense, the following insurance: (i) "All Risk" property insurance for its property's replacement cost; (ii) commercial general liability insurance with a minimum limit of liability of Two Million Dollars (\$2,000,000.00) combined single limit for bodily injury or death/property damage arising out of any one occurrence; (iii) Workers' Compensation Insurance as required by law; and (iv) Automobile Liability with combined single limit of One Million Dollars (\$1,000,000.00) per accident. Such limits may be satisfied by a combination of primary and umbrella policies. The coverage afforded by Licensee's commercial general liability insurance shall apply to Licensor as an additional insured. Licensee's policy shall be primary and any insurance of Licensor's shall be in excess of Licensee's insurance and shall not contribute to it, unless the underlying cause of the claim is caused by Licensor in which case Licensor's insurance shall be primary. Licensee's insurance shall not be canceled or reduced in coverage or in limits during the Term of this Agreement. Licensee shall provide a certificate of insurance and Additional Insured Endorsements to Licensor as of the time of the tender of the consideration as set forth in paragraph 4(a) above.

8. **INTERFERENCE.**

(a) Where there are existing radio frequency user(s) on the Property, the Licensor will provide Licensee with a list of all existing radio frequency user(s) on the Property to allow Licensee to evaluate the potential for interference. Licensee warrants that its use of the Premises will not interfere with existing radio frequency user(s) on the Property so disclosed by Licensor as of the Effective Date, as long as the existing radio frequency user(s) operate and continue to operate within their respective frequencies and in accordance with all applicable laws and regulations. In the event that measurable interference with existing radio frequency occurs, Licensor agrees to take all reasonable action necessary to eliminate such interference, in a reasonable time period. Licensee shall not interfere with Licensor's school programs or activities on the Property and Licensee's Communication Facilities and operations shall comply with all non-interference rules of the Federal Communications Commission ("FCC"). Licensee may terminate this Agreement as set forth in paragraph 6 above if Licensor fails to comply with this paragraph and/or pursue any other remedies available under this Agreement.

(b) Licensor reserves the right to grant, after the date of this Agreement, a lease, license or other right to a third party for the use of the Property, so long as such use does not measurably adversely affect or interfere with the Communication Facility, the operations of Licensee or the rights of Licensee under this Agreement. Licensor warrants to the best of its ability, that any third party licensee will engage in acts or omissions consistent with the business or educational interests of Licensor as a California public school district. Licensor will notify Licensee in writing prior to granting any third party the right to install and operate communications equipment on the Property.

(c) Licensor will not use, nor will Licensor permit its employees, tenants, licensees, invitees or agents to use, any portion of the Property in any way which measurably interferes with the Communication Facility, the operations of Licensee or the rights of Licensee under this

Agreement. Licensor will cause such interference to cease within a reasonable time period after receipt of notice of interference from Licensee, and in no case less than three (3) business days after said notification. In the event any such interference does not cease within the aforementioned time period, Licensee may terminate this Agreement as set forth in paragraph 6 above, in addition to any other rights that it may have at law or in equity, upon notice to Licensor.

(d) Licensee shall comply with all present and future laws, orders and regulations relating to Electromagnetic Fields ("EMF") and Radio-Frequencies ("RF"), including, but not limited to, the standards set by the American National Standards Institute ("ANSI") and FCC and all other local, State and Federal laws, rules, regulations and ordinances applicable to the subject matter of this License Agreement. (The FCC's new RF emission standards went into effect on October 15, 1997. Said standards are set forth in Section 1.1307 et seq. of the FCC Rules and in a related advisory document, "Evaluating Compliance with the FCC Guidelines for Human Exposure to Radio Frequency Electromagnetic Fields," OET Bulletin 65, Edition 97-01, issued August 25, 1997). Notwithstanding anything to the contrary contained in this License Agreement, it is Licensee's responsibility to make sure Licensee's employees and agents are informed of and comply with these FCC standards when conducting any work on or around the Property.

(e) Licensee shall be responsible for compliance with all tower and pole marking and lighting requirements of the Federal Aviation Administration ("FAA") and the FCC, provided it installs, owns and maintains the tower or pole. Should Licensee or Licensor be cited because the tower or pole is not in compliance, and should Licensee fail to cure the conditions of noncompliance within the time frame allowed by the citing agency, after notice of default and expiration of Licensee's period to cure, Licensor may, inter alia, terminate this License Agreement immediately on notice to Licensee or proceed to cure the conditions of noncompliance at Licensee's expense. Licensee shall indemnify and hold Licensor harmless from any fines or other liabilities caused by Licensee's failure to comply with such requirements and shall reimburse Licensor for all of its costs.

9. INDEMNIFICATION.

(a) Licensee agrees to indemnify, defend and hold Licensor harmless from and against any and all third party injury, loss, damage or liability (or any third party claims in respect of the foregoing), and any and all of Licensor's costs or expenses (including reasonable attorneys' fees and court costs), concerning any act or omission of Licensee relating to or arising under the Permitted Uses, any other uses of the Premises by Licensee, or the subject matter of this Agreement, except to the extent attributable to the negligence or intentional acts or omissions of Licensor, its employees, agents or independent contractors.

(b) Licensor agrees to indemnify, defend and hold Licensee harmless from and against any and all third party injury, loss, damage or liability (or any third party claims in respect of the foregoing), and any and all of Licensor's costs or expenses (including reasonable attorneys' fees and court costs), concerning any act or omission of Licensor relating to or arising under the Permitted Uses, any other uses of the Premises by Licensor, or the subject matter of this Agreement, except to the extent attributable to the negligence or intentional acts or omissions of Licensee, its employees, agents or independent contractors.

10. WARRANTIES.

(a) Licensee and Licensor each acknowledge and represent that it is duly organized, validly existing and in good standing and has the right, power and authority to enter into this Agreement and bind itself hereto through the party set forth as signatory for the party below.

(b) Licensor represents and warrants that: (i) Licensor solely owns the Property as a legal lot in fee simple, or controls the Property by lease or license; (ii) the Property is not encumbered by any liens, restrictions, mortgages, covenants, conditions, easements, leases, or any

other agreements of record or not of record, which would adversely affect Licensee's Permitted Use and enjoyment of the Premises under this Agreement; (iii) as long as Licensee is not in default then Licensor grants to Licensee sole, actual, quiet and peaceful use, enjoyment and possession of the Premises; (iv) to the best of Licensor's knowledge, Licensor's execution and performance of this Agreement will not violate any laws, ordinances or covenants, or the provisions of any lease or other agreement binding on the Licensor; and (v) if the Property is or becomes encumbered by a deed to secure a debt, mortgage or other security interest, Licensor will provide promptly to Licensee the name and contact information of such encumbrancer so Licensee may seek a mutually agreeable Subordination, Non-Disturbance and Attornment Agreement.

(c) Licensee represents and warrants that: (i) Licensee shall engage in lawful use of the Premises and for no other purpose; (ii) none of Licensee's acts or omissions on the Property shall cause injury, loss, damage or liability to any third party; (iii) none of Licensee's acts or omissions shall interfere with Licensor's duty to maintain a safe school environment for the pupils of the District; (iv) Licensee will not transport any Hazardous Material on to the Premises in violation of the law; and (v) to the best of Licensee's knowledge, Licensee's execution and performance of this Agreement will not violate any laws, ordinances or covenants, or the provisions of any lease or other agreement binding on the Licensee.

11. ENVIRONMENTAL.

(a) Licensor represents that to the best of Licensor's knowledge, the Premises is free of "Hazardous Materials," as defined in this paragraph, as of the date of this Agreement, *except as noted in the asbestos Hazard Emergency Response Act Report of February 16, 2004* and, to the best of Licensor's knowledge, the Premises has never been subject to any contamination or hazardous conditions resulting in any environmental investigation, inquiry or remediation. Licensor and Licensee agree that each will be responsible for compliance with any and all Hazardous Material laws, including any regulations, guidelines, standards, or policies of any governmental authorities regulating or imposing standards of liability or standards of conduct with regard to any Hazardous Material condition or other matters as may now or at any time hereafter be in effect, that are now or were related to that party's activity conducted in or on the Property. "Hazardous Material" shall mean petroleum or any petroleum product, asbestos, any substances known by the state in which the Property is located to cause cancer and/or reproductive toxicity, and/or any substance, chemical or waste that is identified as hazardous, toxic or dangerous in any applicable federal, state or local law or regulation. Within ten (10) days of the Effective Date of this Agreement, District will disclose and deliver to Licensee relevant reports and records in its possession related to Hazardous Materials on the Property.

(b) Licensor and Licensee agree to hold harmless, defend and indemnify the other from, and to assume all duties, responsibilities and liabilities at the sole cost and expense of the indemnifying party for, payment of penalties, sanctions, forfeitures, losses, costs or damages, and for responding to any action, notice, claim, order, summons, citation, directive, litigation, investigation or proceeding ("Claims") which is related to (i) the indemnifying party's failure to comply with any Hazardous Material law, including without limitation any regulations, guidelines, standards or policies of any governmental authorities regulating or imposing standards of liability or standards of conduct with regard to any Hazardous Material conditions or matters as may now or hereafter be in effect, or (ii) any Hazardous Material conditions to the extent that they are caused by the activities conducted by the party thereon, except for Hazardous Materials existing on the Property prior to the Commencement Date in which case Licensor shall indemnify, defend and hold Licensee harmless from any and all Claims. Licensor and Licensee agree, on a best efforts basis, to cooperate and assist in mitigating (i) and (ii) if they occur.

(c) The indemnifications of this Paragraph 11 Environmental specifically include reasonable costs, expenses and fees incurred in connection with any investigation of Property

conditions or any clean-up, remediation, removal or restoration work required by any governmental authority. The provisions of this Paragraph 11 Environmental will survive the expiration or termination of this Agreement.

(d) In the event Licensee becomes aware of any Hazardous Materials on the Property, or any Hazardous Material condition or matter relating to the Property that, in Licensee's sole determination, renders the condition of the Premises or Property unsuitable for Licensee's use, or if Licensee believes that the licensing or continued licensing of the Premises would expose Licensee to undue risks of government action, intervention or third-party liability, Licensee will have the right, in addition to any other rights it may have at law or in equity, to terminate the Agreement as set forth in paragraph 6 above. In the event that Licensee terminates the Agreement pursuant to this section, Licensee shall return the Premises to the condition in which it existed prior to the execution of the Agreement, reasonable wear and tear and casualty beyond Licensee's control excepted, unless District agrees in writing that the Premises remain in its present condition, taking into consideration the existence of Hazardous Materials when restoring the Premises. If Licensee does not return the Premises to the condition which existed on the Commencement Date, reasonable wear and tear and casualty beyond Licensee's control excepted, District may return the Premises to such condition and Licensee shall reimburse District for all of its costs.

12. **ACCESS.** At all times throughout the Term of this Agreement, and at no additional charge to Licensee, Licensee and its employees, agents, and subcontractors, will have pedestrian and vehicular access to and over the Property, solely for the installation, maintenance and operation of the Communication Facility and any utilities serving the Premises upon providing District with two (2) hour telephonic notice except in the case of an emergency, when Licensee shall be allowed access, provided that it notify the Licensor as soon as reasonably practicable thereafter. Licensor agrees to provide to Licensee such codes, keys and other instruments necessary for such access at no additional cost to Licensee. Licensor will provide access keys and codes for up to three Licensee designees. Licensee shall keep any codes, keys or other instruments necessary for such access confidential or secure as applicable. In the event any public utility is unable to use the access provided to Licensee then the Licensor agrees, to the extent it reasonably can, to grant additional access either to Licensee or to the public utility, for the benefit of Licensee, at no cost to Licensee.

13. **REMOVAL/RESTORATION.** All portions of the Communication Facility brought onto the Premises by Licensee will be and remains Licensee's personal property and, at Licensee's option, may be removed by Licensee at any time during the Term. Licensor covenants and agrees that no part of the Communication Facility constructed, erected or placed on the Premises by Licensee will become, or be considered as being affixed to or a part of, the Property, it being the specific intention of the Licensor that all improvements of every kind and nature constructed, erected or placed by Licensee on the Premises will be and remain the property of the Licensee and may be removed by Licensee at any time during the Term. At the earlier of the expiration or termination of this Agreement, Licensee will be responsible for the replacement of any trees, shrubs, or other vegetation if any are damaged by Licensee's removal, and Licensee will be required to remove from the Premises any foundations, underground utilities, or any part of the Communication Facility unless District agrees in writing to allow any such item to remain. If, upon termination or expiration, Licensee does not return the Premises to the condition which existed prior to the Commencement Date, reasonable wear and tear and casualty beyond Licensee's control excepted, District may return the Premises to such condition and Licensee shall reimburse District for all of its costs.

14. MAINTENANCE/UTILITIES.

(a) Licensee will keep and maintain the Premises in good condition, reasonable wear and tear and damage from the elements excepted. Licensor will maintain and repair the Property and access thereto, in good and tenantable condition, subject to reasonable wear and tear and damage from the elements. Licensee will remove graffiti within three (3) business days of notification.

(b) Licensee will be responsible for paying on a monthly or quarterly basis all utilities charges for electricity, telephone service or any other utility used or consumed by Licensee for utility access as set forth in Exhibit 1. Licensor will reasonably cooperate with any utility company requesting an access, under and across the Property in order for the utility company to provide service to the Licensee. Repair or maintenance of Licensee's utilities or Communications Facilities shall be subject to the access restrictions contained in Section 12 above. Licensor will not be responsible for interference with, interruption of or failure, beyond the reasonable control of Licensor, of such services to be furnished or supplied by Licensor.

15. TAXES. In the event that any property tax and/or assessments are levied on the Communications Facility, Licensee will be responsible for paying within thirty (30) days of receipt of reasonably sufficient documentation from Licensor all charges for these taxes and/or assessments which are attributable to Licensee's use and occupancy thereof. Notwithstanding anything contained herein to the contrary, Licensee's use of the Property under this License Agreement may be determined to create a "taxable possessory interest" in said Property and Licensee may be subject to the assessment of property taxes based upon such a possessory interest. As between the Licensor and the Licensee, Licensee shall be solely responsible for the payment of any and all such property taxes levied on such interest, including any penalties and interest in connection therewith. Licensor hereby grants Licensee the right to contest or challenge such taxes, whether in administrative proceeding or other venues on behalf of Licensor or Licensee, and to withhold payment of such taxes pending any such contest or challenge, if such withholding is permitted by the legal, equitable or administrative rules associated with such contest or challenge. Licensor agrees to provide timely notice of annual tax assessment to Licensee, sufficient to contest or challenge such assessment.

16. DEFAULT AND RIGHT TO CURE.

(a) In addition to other provisions in this Agreement setting forth breaches, the following will be deemed a default by Licensee and a breach of this Agreement: (i) non-payment of Rent if such Rent remains unpaid for more than twenty (20) days after Licensee's receipt of written notice from Licensor of such failure to pay; or (ii) Licensee's failure to perform any other term or condition under this Agreement within thirty (30) days after receipt of written notice from Licensor specifying the failure. No such failure, however, will be deemed to exist if Licensee has commenced to cure such default within such period and provided that such efforts are prosecuted to completion with reasonable diligence. Delay in curing a default will be excused if due to causes beyond the reasonable control of Licensee. If Licensee remains in default beyond any applicable cure period, Licensor will have the right to exercise any and all rights and remedies available to it under law and equity except where explicitly stated in this Agreement, including the right to cure Licensor's default and to deduct the costs of such cure from any monies due to Licensor from Licensee.

(b) The following will be deemed a default by Licensor and a breach of this Agreement: Licensor's failure to perform any term or condition under this Agreement within thirty (30) days after receipt of written notice from Licensee specifying the failure. No such failure, however, will be deemed to exist if Licensor has commenced to cure the default within such period and provided such efforts are prosecuted to completion with reasonable diligence. Delay in curing a default will be excused if due to causes beyond the reasonable control of

Licensor. If Licensor remains in default beyond any applicable cure period, Licensee will have the right to exercise any and all rights available to it under law and equity except where explicitly stated in this Agreement, including the right to cure Licensor's default and to deduct the costs of such cure from any monies due to Licensor from Licensee.

17. **ASSIGNMENT/SUB-LICENSE.** Licensee shall not have the right to assign this Agreement or sub-license the Premises and its rights herein, in whole or in part, provided however, Licensee may assign this Agreement upon written notice to Licensor, to any person controlling, controlled by, or under common control with Licensee, or any person or entity that acquires Licensee's radio communications business and assumes all obligations of Licensee under this Agreement. Upon such assignment, Licensee shall be relieved of all liabilities and obligations hereunder, provided that such assignee (i) has a net worth capable of maintaining the equipment and performing all obligations of this License (ii) does not engage in any activity which interferes with, or is otherwise incompatible with, Licensor's activities as a California public school district and provider of education services to minors, or which otherwise violates any Federal, State or local law or ordinance, and (iii) affirmatively provides a writing to Licensor indicating that such assignee accepts all duties and obligations under this Agreement on behalf of assignee.

18. **NOTICES.** All notices, requests, demands and communications hereunder will be given by first class certified or registered mail, return receipt requested, or by a nationally recognized overnight courier, postage prepaid, to be effective when properly sent and received. Notices will be addressed to the parties as follows:

If to Licensee: T-Mobile USA, Inc.
12920 SE 38th Street
Bellevue, WA 98006
Attn: PCS Lease Administrator
With a copy to: Attn: Legal Dept.

With a copy to: T-Mobile West Corporation
2380-A Bisso Lane
Concord, CA 94520
Attn: Lease Administration Manager

And with a copy to: Attn: Legal Dept.

If to Licensor: Richard Nicoll, Interim Superintendent
Mt. Diablo Unified School District
1936 Carlotta Drive
Concord, CA 94519

With a copy to: Pete Pedersen, Assistant Superintendent

And with a copy to: Office of the General Counsel

Either party hereto may change the place for the giving of notice to it by thirty (30) days prior written notice to the other as provided herein.

19. **SEVERABILITY.** If any term or condition of this Agreement is found unenforceable, the remaining terms and conditions will remain binding upon the parties as though said unenforceable provision were not contained herein.

20. **CONDEMNATION.** In the event Licensor receives notification of any condemnation proceedings affecting the Property, Licensor will provide notice of the proceeding to Licensee within forty-eight (48) hours. If a condemning authority takes all of the Property, or a portion sufficient, in Licensee's sole determination, to render the Premises unsuitable for Licensee, this Agreement will terminate as of the date designated by Licensee's notice of termination hereunder. The parties will each be entitled to pursue their own separate awards in the condemnation proceeds, which for Licensee will include, where applicable, the value of its Communication Facility, moving expenses, prepaid Rent, and business dislocation expenses, provided that any award to Licensee will not diminish Licensor's recovery. Licensee will be entitled to reimbursement for any prepaid Rent on a pro-rata basis. In the event Licensee is required to vacate the Property pursuant to a condemnation action, Licensee shall remove and bear all costs associated with moving the Communications Facility from the Premises, and shall return the Premises to the condition that existed on the Rent Commencement Date, reasonably taking into account the casualty and wear and tear, the repairs for which Licensee shall not be responsible. If, upon condemnation, Licensee does not return the Premises to the condition which existed prior to the Commencement Date, reasonable wear and tear and casualty beyond Licensee's control excepted, District may return the Premises to such condition and Licensee shall reimburse District for all of its costs.

21. **CASUALTY.** Licensor will provide notice to Licensee of any casualty affecting the Property within forty-eight (48) hours of the casualty. If any part of the Communication Facility or Property is damaged by fire or other casualty so as to render the Premises unsuitable, in Licensee's sole determination, then Licensee may terminate this Agreement by providing written notice to the Licensor, which termination will be effective as of the date of such damage or destruction. Upon such termination, Licensee will be entitled to collect all insurance proceeds payable to Licensee on account thereof and to be reimbursed for any prepaid Rent on a pro-rata basis. In the event that Licensee terminates this Agreement pursuant to this provision, Licensee shall remove and bear all costs associated with moving the Communications Facility from the Premises, and shall return the Premises to the condition that existed on the Rent Commencement Date, reasonably taking into account the casualty, the repairs for which Licensee shall not be responsible.

22. **WAIVER OF LICENSOR'S LIENS.** Licensor waives any and all lien rights it may have, statutory or otherwise, concerning the Communication Facility or any portion thereof. The Communication Facility shall be deemed personal property for purposes of this Agreement, regardless of whether any portion is deemed real or personal property under applicable law, and Licensor consents to Licensee's right to remove all or any portion of the Communication Facility from time to time in Licensee's sole discretion and without Licensor's consent.

23. **MISCELLANEOUS.**

(a) **Amendment/Waiver.** This Agreement cannot be amended, modified or revised unless done in writing and signed by an authorized agent of the Licensor and an authorized agent of the Licensee. No provision may be waived except in a writing signed by both parties.

(b) **Memorandum/Short Form License.** Either party will, at any time upon fifteen (15) business days prior written notice from the other, execute, acknowledge and deliver to the other a recordable Memorandum of License. Either party may record this Memorandum of License at any time, in its absolute discretion. Any such Memorandum of License may assert the existence of this Agreement, but shall not disclose the financial terms and conditions of this Agreement.

(c) **Bind and Benefit.** The terms and conditions contained in this Agreement will run with the Property and bind and inure to the benefit of the parties, their respective heirs, executors, administrators, successors and assigns.

(d) **Entire Agreement.** This Agreement and the exhibits attached hereto, all being a part hereof, constitute the entire agreement of the parties hereto and will supersede all prior offers, negotiations and agreements with respect to the subject matter of this Agreement.

(e) **Governing Law and Venue.** This Agreement will be governed by the laws of the state in which the Premises are located, without regard to conflicts of law. Venue shall be with the appropriate state or federal court located in Contra Costa County or in the Northern District of California, respectively.

(f) **Interpretation.** Unless otherwise specified, the following rules of construction and interpretation apply: (i) captions are for convenience and reference only and in no way define or limit the construction of the terms and conditions hereof; (ii) use of the term "including" will be interpreted to mean "including but not limited to"; (iii) whenever a party's consent is required under this Agreement, except as otherwise stated in the Agreement or as same may be duplicative, such consent will not be unreasonably withheld, conditioned or delayed; (iv) exhibits are an integral part of the Agreement and are incorporated by reference into this Agreement; (v) use of the terms "termination" or "expiration" are interchangeable; and (vi) reference to a default will take into consideration any applicable notice, grace and cure periods.

(g) **Estoppel.** Either party will, at any time upon twenty (20) business days prior written notice from the other, execute, acknowledge and deliver to the other a statement in writing (i) certifying that this Agreement is unmodified and in full force and effect (or, if modified, stating the nature of such modification and certifying this Agreement, as so modified, is in full force and effect) and the date to which the Rent and other charges are paid in advance, if any, and (ii) acknowledging that there are not, to such party's knowledge, any uncured defaults on the part of the other party hereunder, or specifying such defaults if any are claimed. Any such statement may be conclusively relied upon by any prospective purchaser or encumbrancer of the Premises. The requested party's failure to deliver such a statement within such time will be conclusively relied upon by the requesting party that (i) this Agreement is in full force and effect, without modification except as may be properly represented by the requesting party, (ii) there are no uncured defaults in either party's performance, and (iii) no more than one month's Rent has been paid in advance.

(h) **No Electronic Signatures/No Option.** The submission of this Agreement to any party for examination or consideration does not constitute an offer, reservation of or option for the Premises based on the terms set forth herein. This Agreement will become effective as a binding Agreement only upon the handwritten legal execution, acknowledgment and delivery hereof by Licensor and Licensee.

(i) **Subject to Approval of Board.** This Agreement confers no legal or equitable rights until it is approved by the District Board of Trustees at a lawfully conducted public meeting.

[SIGNATURES APPEAR ON THE NEXT PAGE]

IN WITNESS WHEREOF, the parties have caused this Agreement to be effective as of the last date written below.

"LICENSOR"

Mt. Diablo Unified School District, a
California public school district

By: _____

Print Name: _____

Its: _____

Date: _____

"LICENSEE"

T-Mobile West Corporation,
a Delaware corporation

By: _____

Print Name: Martin Vernon

Its: Director NorCal/San Francisco
Engineering and Operations

Date: _____

EXHIBIT 1
Communication Facility

SITE ADDRESS
 154 CARLOTTA DR.
 CONCORD, CA 94519

OWNER
 MOUNT DIABLO UNIFIED SCHOOL DIST.
 1935 CARLOTTA DR.
 CONCORD, CA 94519

T-Mobile
 T-MOBILE WEST CORPORATION
 170 Emerald Bay Drive, Suite 100, Sausalito, CA 94965
SITE#:BA41426B

Peak Site-Com
 853 Lincoln Way, Suite 106
 Auburn, California 95603
 Phone (530) 885-6160
 E-Mail info@peaksite.com

The project, including identification, which is the preliminary property of the applicant, is not a final project and is subject to change without notice. The applicant is responsible for obtaining all necessary permits and approvals from the appropriate local agencies.

REVISIONS

| NO. | DATE | BY |
|-----|---------|-----|
| 1 | 7-27-09 | MRT |
| 2 | 8-4-09 | MRT |

PROJECT
 MOUNT DIABLO UNIFIED SCHOOL DIST.

PREPARED BY
 PEAK SITE-COM

DATE
 7-27-09

SCALE
 AS NOTED

PROJECT NO.
 7-27-09

SHEET
 A-1

OVERALL SITE PLAN

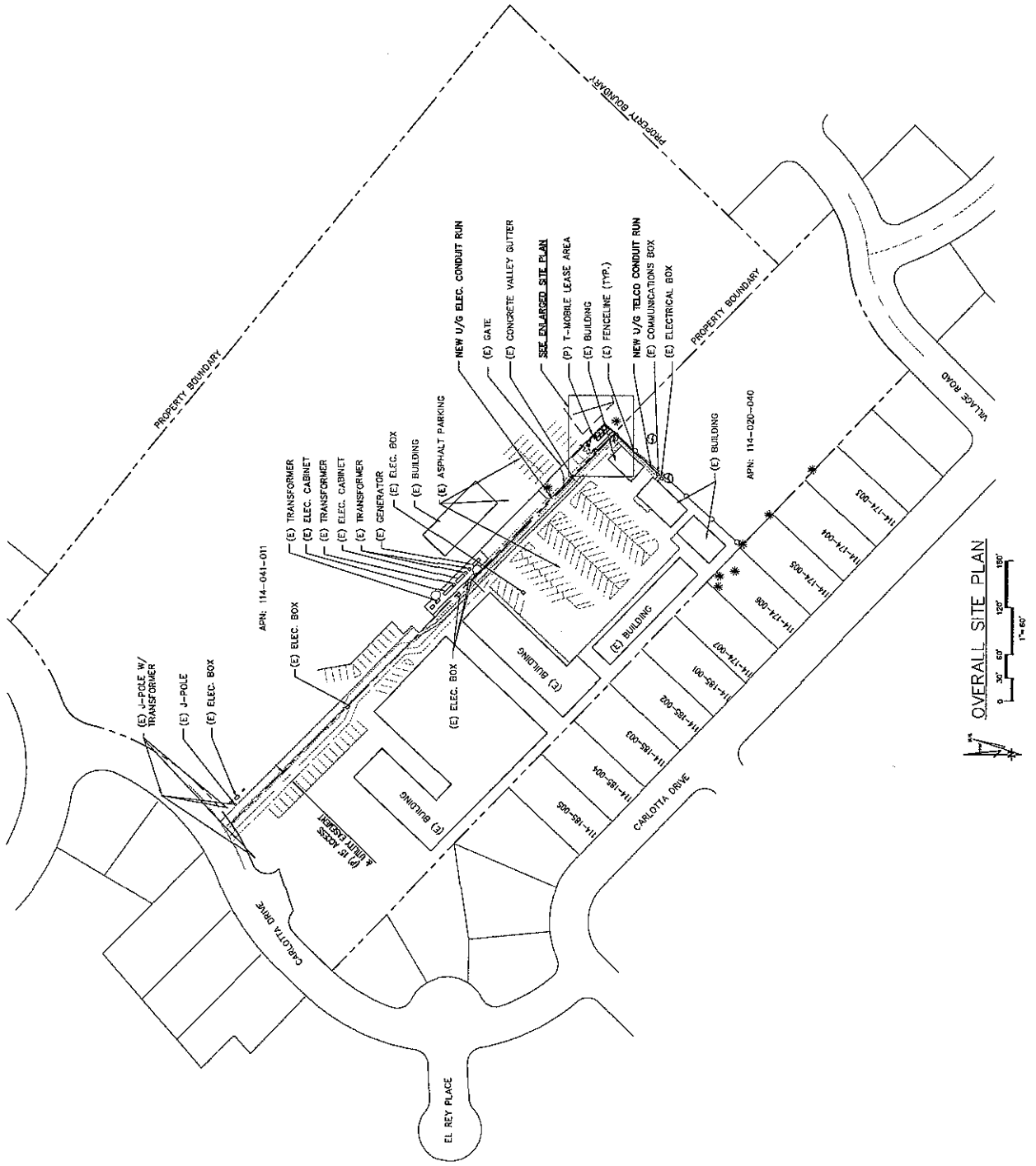

OVERALL SITE PLAN

1" = 60'

KEY NOTES:

1. NEW 1/2" CHAIN LINK FENCE ON UNDISTURBED SUPPORT
2. NEW 1/2" CHAIN LINK FENCE ON UNDISTURBED SUPPORT
3. NEW 1/2" CHAIN LINK FENCE ON UNDISTURBED SUPPORT
4. NEW FULLY ENCLOSED CONCRETE BRIDGE # 14
5. NEW 1/2" CHAIN LINK FENCE W/ VINYL SLATS TO EXISTING CONCRETE BRIDGE # 14
6. NEW 200A WATER MAIN ON NEW UNDISTURBED SUPPORT
7. NEW 8" WATER MAIN ON NEW UNDISTURBED SUPPORT
8. NEW 8" WATER MAIN ON NEW UNDISTURBED SUPPORT
9. NEW 8" WATER MAIN ON NEW UNDISTURBED SUPPORT
10. NEW 100A T-NOBLE SITE LIGHT AT 8' A.D.
11. NEW 100A T-NOBLE SITE LIGHT AT 8' A.D.
12. NEW 100A T-NOBLE SITE LIGHT AT 8' A.D.
13. NEW 100A T-NOBLE SITE LIGHT AT 8' A.D.
14. NEW 100A T-NOBLE SITE LIGHT AT 8' A.D.
15. NEW 100A T-NOBLE SITE LIGHT AT 8' A.D.

SITE ADDRESS
 1000 CAROLINA DR.
 CONCORD, CA 94519

Mount Diablo Unified School Dist.
 1035 CAROLINA DR.
 CONCORD, CA 94519

T-Mobile
 T-MOBILE WEST CORPORATION
 1740 Central Exp. Hwy., Suite 100-1000, Concord, CA 94503
SITE# BA41426B

Peek Site-Com
 853 Lincoln Way, Suite 105
 Auburn, California 95603
 Phone (530) 885-6160
 E-Mail: info@peeksite.com

REVISIONS

| NO. | DESCRIPTION | DATE | BY |
|-----|---------------|---------|-----|
| 1 | ISSUE DRAWING | 7-27-09 | WRT |
| 2 | ISSUE DRAWING | 8-4-09 | WRT |

PROJECT: MOUNT DIABLO UNIFIED SCHOOL DIST.
DRAWING TITLE: ENLARGED SITE PLAN

DATE: 7-27-09
 DRAWING NO.: A-1.1
 SHEET NO. OF

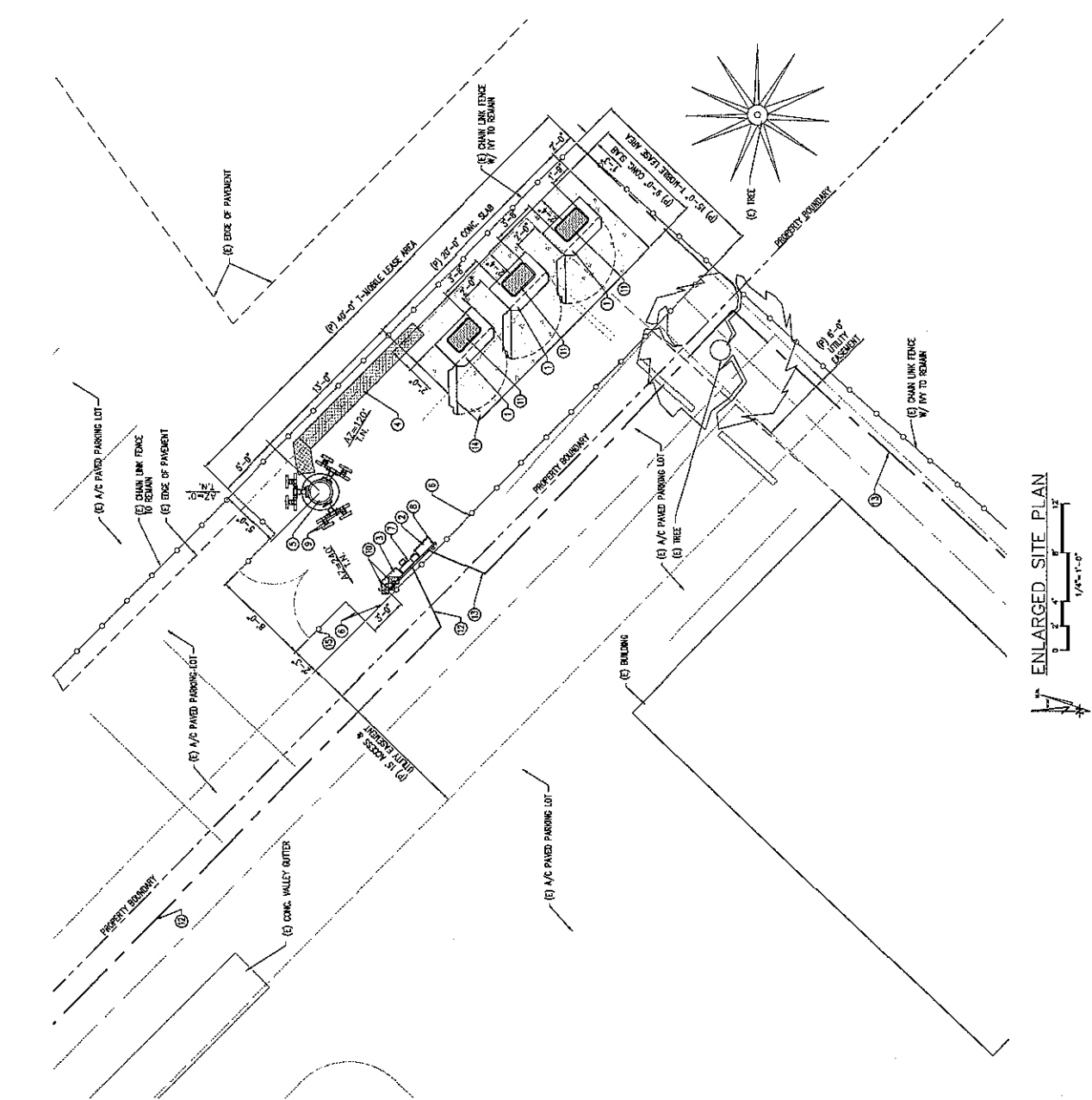

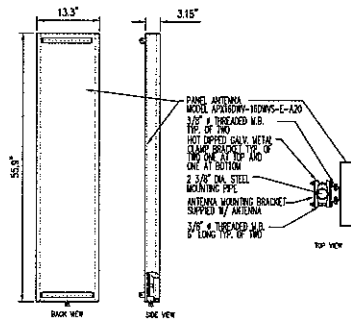

TYP. ANTENNA DETAIL
NOT TO SCALE

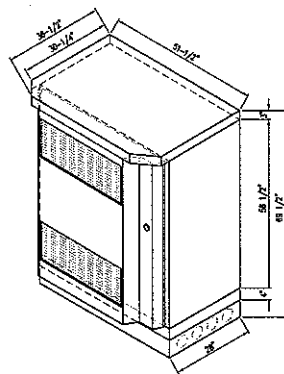

TYP. BTS DETAIL
NOT TO SCALE

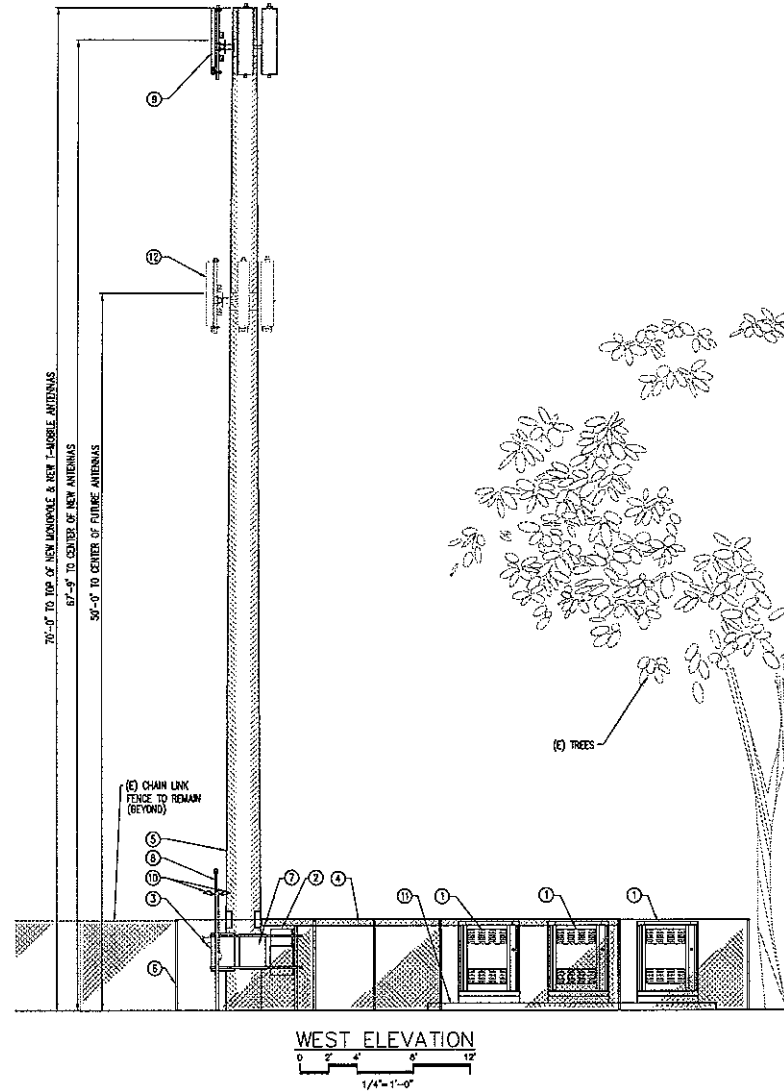

WEST ELEVATION
0 2' 4' 6' 12'
1/4" = 1'-0"

KEY NOTES:

- 1 NEW BTS UNITS
- 2 NEW TELCO CABINET ON UNISTRUT SUPPORT
- 3 NEW 200 AMP ELECTRICAL PANEL ON UNISTRUT SUPPORT
- 4 NEW FULLY ENCLOSED COAX CABLE BRIDGE @ 6' AGL
- 5 NEW MONOPOLE
- 6 NEW 6" ZALL CHAIN LINK FENCE W/ VINYL SLATS TO MATCH (E)
- 7 NEW 200A METER MAIN ON NEW UNISTRUT SUPPORT
- 8 NEW OPT UNIT TO MOUNT TO NEW UNISTRUT SUPPORT
- 9 NEW T-MOBILE WIRELESS ANTENNAS
NEW OF (1) PROPOSED & (4) EXISTING PER SECTION FOR A TOTAL OF (5) ANTENNAS ON NEW MONOPOLE
- 10 (2) NEW 100w T-MOBILE SITE LIGHT AT 6' AGL
- 11 NEW 6" THK CONC. SLAB WITH #4 REBAR AT 24" OC EACH WAY AT MID SLAB FOR T-MOBILES
- 12 FUTURE ANTENNAS BY OTHERS

SITE ADDRESS

1936 CARLOTTA DR.
CONCORD, CA 94519

OWNER: MOUNT DIABLO UNIFIED SCHOOL DIST.

OWNER ADDRESS:
1936 CARLOTTA DR.
CONCORD, CA 94519

T-Mobile
T-MOBILE WEST CORPORATION
1750 Conditville Hills Dr., Suite 100 • Sacramento, CA 95825

SITE#: BA41426B

Peek Site--Com

853 Lincoln Way, Suite 106
Auburn, California 95603
Phone (530) 885-6160
E-Mail info@peeksitecom.com

This drawing contains information which is the proprietary property of DESCHER. No unauthorized reuse or duplication of these plans or any information contained herein, without the express written consent.

| REVISIONS | | |
|-----------|--------------------|-------------|
| NO | DESCRIPTION | DATE BY |
| 1 | BIDS ZONING DOC.'S | 7-21-09 VRY |
| 2 | LOOK ZONING DOC.'S | 8-4-09 VRY |
| | | |
| | | |
| | | |
| | | |

PROJECT: MOUNT DIABLO UNIFIED SCHOOL DIST.

| DRAWING TITLE: ELEVATIONS | | | |
|---------------------------|----------------|-----------------------|------------------|
| SEAL | DRAWN BY: VRY | PROJECT NO.: BA41426B | DRAWING NO.: A-2 |
| | CHECKED BY: | CADD FILE NO.: | DRAWING NO.: |
| | SCALE AS NOTED | DATE: 7-27-09 | PROJECT: |
| | DATE: 7-27-09 | PROJECT: | SHEET: 01 |

Exhibit 1 (4)

EXHIBIT 2

The location of the Premises within the Property (together with access and utilities) is more particularly described and depicted as follows:

However, it is expressly agreed and understood by and between the Licensor and Licensee that the exact and precise location of the Licensee's Communication Facilities are subject to review and approval by the planning and/or zoning boards having jurisdiction over the "Premises".

Therefore, it is expressly agreed and understood by and between and Licensee that the precise location of the Premises as shown on Exhibit "2" may be modified by the Licensee in order to comply with and obtain necessary planning and/or zoning approvals, and any and all other approvals necessary for Licensee's intended use of the property, with the understanding that the Premises will consist of approximately six hundred (600) square feet. The Premises as described herein may therefore be modified by the Licensee to reflect the final engineering design. An amended Exhibit "2" (if necessary) will be provided by the Licensee and attached to the license in place of the existing Exhibit "2", a copy of which will be provided to the Licensor for review prior to being incorporated into the license.

LICENSE AGREEMENT

THIS LICENSE AGREEMENT ("Agreement" or "License Agreement"), dated as of the latter of the signature dates below (the "Effective Date"), is entered into by MT. DIABLO UNIFIED SCHOOL DISTRICT, a California public school district having a mailing address 1936 Carlotta Drive, Concord CA 94519 (hereinafter referred to as "Licensor" or "District") and T-Mobile West Corporation, a Delaware corporation (hereinafter referred to as "Licensee"), having a mailing address of 12920 SE 38th Street, Bellevue, WA 98006, Attn: PCS Lease Administrator, with a copy to: Attn: Legal Dept..

RECITALS

This License Agreement is entered into based on the following facts, circumstances and understandings:

A. Licensor is a California public school district which owns certain real property commonly known as Riverview Middle School, 205 Pacifica Avenue, Bay Point, CA 94565 ("Property"). Licensee desires to use a portion of Licensor's Property for a ground area space of approximately four hundred and eighty (480) square feet and communications fixtures, more particularly described in Exhibit 1 ("the Premises"), with any necessary easements over other portions of Licensor's Property and/or shared use of Licensor's easements over other real property necessary for Licensee's access to the Premises, as described in Exhibit 1.

B. Licensee is a communications carrier that desires to construct and operate a wireless communications site at the Premises as part of its communications network.

C. Licensor is willing to license the Premises to Licensee for Licensee's proposed use subject to the terms and conditions of this License Agreement.

The parties, in exchange for good and valuable consideration which is hereby acknowledged, agree as follows:

AGREEMENT

1. **GRANT OF LICENSE.** Licensor hereby grants a license to Licensee to use the Premises for Licensee's proposed use, subject to the following terms and conditions ("**License**"). Except as set forth in Recital A above, the term "easement" in this Agreement shall not confer any greater right than a license as described herein. This License shall be deemed a license coupled with an interest, the interest being the equipment described herein. Notwithstanding the above, Licensor agrees that it will not terminate this License and the rights contained herein, unless as otherwise set forth herein below or as required by law.

2. **PERMITTED USE.** Licensee may use the Premises for the transmission and reception of communications signals and the installation, construction, maintenance, operation, repair, replacement and upgrade of its communications fixtures and related equipment, cables, accessories and improvements, which may include a suitable support structure, associated antennas, equipment shelters or cabinets and fencing and any other items reasonably necessary to the successful and secure use of the Premises (collectively, the "**Communication Facility**"), as set forth in Exhibit 1. Pursuant to the provisions set forth in paragraph 5(c) below, Licensee has the right to test and survey the Property upon advance notice to, and written approval from,

District; Licensee further has the right to add, modify and/or replace equipment in order to be in compliance with any current or future federal, state or local mandated application, including, but not limited to, emergency 911 communication services, at no additional cost to Licensee or Licensor (collectively, the "**Permitted Use**"). Licensor and Licensee agree that any portion of the Communication Facility conceptually described on **Exhibit 1** will not be deemed to limit Licensee's Permitted Use though it will limit Licensee to the Premises and to uses related to Licensee's use of the Premises as a Communication Facility. If **Exhibit 1** includes drawings of the initial installation of the Communication Facility, Licensor's execution of this Agreement will signify Licensor's approval of **Exhibit 1**. Licensee has the right to install and operate transmission cables from the equipment shelter or cabinet to the antennas as set forth in Exhibit 1, electric lines from the main feed to the equipment shelter or cabinet and communication lines from the main entry point to the equipment shelter or cabinet, and to make improvements, alterations, upgrades or additions appropriate for Licensee's use ("**Licensee Changes**") both set forth in Exhibit 1, or if not set forth, after receiving District's written approval. Licensee shall construct a fence around the Premises and shall undertake all appropriate means to secure the Premises. Licensee agrees to comply with all applicable governmental laws, rules, statutes and regulations, relating to its use of the Communication Facility on the Premises. Upon providing prior written notice to Licensor, Licensee has the right to modify, supplement, replace, upgrade, expand the equipment, increase the number of antennas or relocate the Communication Facility within the Premises at any time during the term of this Agreement. Licensee will be allowed to make such alterations to the Property in order to accomplish Licensee's Changes, or to insure that Licensee's Communication Facility complies with all applicable federal, state or local laws, rules or regulations. However, any modifications which exceed the dimensions of the Premises or materially alter the exterior appearance of the Communication Facility shall require Licensor's prior written consent. In the event Licensee desires to modify or upgrade the Communication Facility, and Licensee requires an additional portion of the Property (the "**Additional Premises**") for such modification or upgrade, Licensor agrees to consider expanding this License Agreement to include the Additional Premises, as may be acceptable to Licensor, upon the same terms and conditions set forth herein, except that the Rent shall increase, in conjunction with the use of the Additional Premises by a reasonable amount consistent with rental rates then charged for comparable portions of real property being in the same area, or upon any different terms and conditions as may be agreed upon by the parties. Licensor shall not be required to grant use of Additional Premises. In the event that Licensor grants use of Additional Premises, Licensor agrees to take such actions and enter into and deliver to Licensee such documents as Licensee reasonably requests in order to effect and memorialize the License of the Additional Premises to Licensee. Licensee agrees not to include signage on the Premises except for emergency signage shown in Exhibit 1 and that otherwise may be required by law.

3. **TERM.**

(a) The initial License term will be five (5) years ("**Initial Term**"), commencing upon Licensee's start of construction or October 1, 2010, whichever first occurs. The Initial Term will terminate on the fifth (5th) annual anniversary of the Effective Date.

(b) This Agreement will automatically renew for four (4) additional five (5) year term(s) (each five (5) year term shall be defined as the "**Extension Term**"), upon the same terms and conditions, but subject to the provisions set forth in paragraph 4(c) below, unless the Licensee notifies the Licensor in writing of Licensee's intention not to renew this Agreement at least sixty (60) days prior to the expiration of the existing Term.

(c) If Licensee remains in possession of the Premises after the termination or expiration of this Agreement then Licensee will be deemed to be occupying the Premises on a month to month basis (the "**Holdover Term**"), subject to the terms and conditions of this Agreement.

(d) The Initial Term, the Extension Term and the Holdover Term are collectively referred to as the Term ("**Term**").

4. **CONSIDERATION.** In consideration for District granting Licensee the License as set forth in this Agreement:

(a) Licensee shall pay District a one-time payment in the amount of Five Thousand and No/100 Dollars (\$5,000.00); provided that Licensee completes its testing as outlined in Section 5 below and Licensee elects to commence construction. This payment shall represent a signing fee and is a one-time only payment, due at the time that Licensee completes its testing as outlined in Section 5 below and Licensee elects to commence construction.

(b) Commencing on the first day of the month following the date that Licensee commences construction, or October 1, 2010, whichever occurs earlier (the "**Rent Commencement Date**"), Licensee will pay the Licensor a monthly rental payment of Three Thousand and No/100 Dollars (\$3,000.00) ("**Rent**"), at the address set forth above, on or before the fifth (5th) day of each calendar month in advance. In partial months occurring after the Rent Commencement Date, Rent will be prorated. The initial Rent payment will be forwarded by Licensee to Licensor within thirty (30) days after the Rent Commencement Date.

(c) Starting at the end of first year after the Rent Commencement Date, and for each year following thereafter, the monthly Rent will increase by three percent (3 %) over the Rent paid during the previous year.

5. **CONDITION PRECEDENT: APPROVALS.**

(a) Licensor agrees that Licensee's ability to use the Premises is contingent upon the suitability of the Premises for Licensee's Permitted Use and Licensee's ability to obtain and maintain all governmental licenses, permits, approvals or other relief required of or deemed necessary or appropriate by Licensee for its use of the Premises, including without limitation applications for zoning variances, zoning ordinances, amendments, special use permits, and construction permits (collectively, the "**Government Approvals**"). Licensor authorizes Licensee to prepare, execute and file all required applications to obtain Government Approvals for Licensee's Permitted Use under this Agreement and agrees to reasonably assist Licensee with such applications and with obtaining and maintaining the Government Approvals. In addition, Licensee shall have the right to initiate the ordering and/or scheduling of necessary utilities as set forth in Exhibit 1.

(b) Licensee has the right to obtain a title report or commitment for a leasehold title policy from a title insurance company of its choice and to have the Property surveyed by a surveyor of Licensee's choice within forty five (45) days after execution of this Agreement. If the survey results show that the condition of the Premises is unsatisfactory for the permitted use, Licensee will have the right to terminate this Agreement upon notice to District.

(c) Licensee may also perform and obtain, at Licensee's sole cost and expense, soil borings, percolation tests, engineering procedures, environmental investigation or other tests or reports on, over, and under the Premises, necessary to determine if the Licensee's use of the Premises will be compatible with Licensee's engineering specifications, system, design, operations or Government Approvals. Licensee shall provide District with twenty four (24) hour advance written notice of any testing it plans to undertake pursuant to this section and will tender true and correct copies of any and all such borings, tests, investigations or reports to District. At completion of testing, Licensee shall immediately return the Premises to the condition in which it existed prior to the Licensee undertaking any testing. If Licensee does not immediately return Premises to the condition which existed prior to Licensee undertaking its testing, District may repair the damage and Licensee shall reimburse District for all of its costs. Licensee shall conduct its tests and construction in such a manner that they shall not interfere with the school

programs or activities or jeopardize the safety of Licensor's students, employees and invitees, licensees, and agents of Licensor.

6. TERMINATION. This Agreement may be terminated, without penalty or further liability, as follows:

(a) by Licensor for non-payment of Rent if such Rent remains unpaid for more than twenty (20) days after Licensee's receipt of written notice from Licensor of such failure to pay;

(b) by either party on thirty (30) days written notice, if the other party remains in default under Paragraph 16 Default and Right to Cure of this Agreement after the applicable cure periods; if Licensee defaults, Licensee shall immediately return the Premises to the condition in which it existed prior to the execution of the Agreement, reasonable wear and tear and loss beyond Licensee's control excepted, unless District agrees in writing that the Premises can remain in its present condition. If Licensor defaults, and Licensee elects to terminate this Agreement, Licensee shall remove the Communication Facility and return the Premises to the condition in which it existed prior to the execution of this Agreement.

(c) by Licensee upon written notice to Licensor, if Licensee is unable to obtain, or maintain, any required approval(s) or the issuance of a license or permit by any agency, board, court or other governmental authority necessary for the construction or operation of the Communication Facility as now or hereafter intended by Licensee; or if Licensee determines in its sole discretion that the cost of obtaining or retaining the same is commercially unreasonable; Licensee shall immediately return the Premises to the condition in which it existed prior to the Commencement Date, reasonable wear and tear and loss beyond Licensee's control excepted, unless District agrees in writing that the Premises remain in its present condition;

(d) by Licensee upon written notice to Licensor for any reason, at any time prior to commencement of construction by Licensee;

(e) by Licensee upon sixty (60) days prior written notice to Licensor for any reason, so long as Licensee pays Licensor a termination fee equal to three (3) months Rent, at the then current rate, provided, however, that no such termination fee will be payable on account of the termination of this Agreement by Licensee under any one or more of Paragraphs 5(b) Approvals, 6(b) Termination, 6(c) Termination, 6(d) Termination, 8 Interference, 11(d) Environmental, 20 Condemnation or 21 Casualty of this Agreement. Licensee shall return the Premises to the condition in which it existed prior to the Commencement Date, reasonable wear and tear and loss beyond Licensee's control excepted, unless District agrees in writing that the Premises remain in its present condition; or

(f) by District, after the expiration of the first Extension Term, if any, upon three hundred sixty-five (365) days advance written notice to Licensee.

(g) In addition to termination rights as provided in Section 6 of this Agreement, this Agreement may be terminated immediately by Licensor without any penalty or further liability by or of Licensor in the event there is a termination made pursuant to an official non-appealable order of a county, state or national governmental health agency having proper jurisdiction, including all state agencies with any oversight over District as a California public school district, including but not limited to, CDE, DSA, DTSC, etc., or by any court of competent jurisdiction, that an electromagnetic field associated with facilities like those operated by Licensee constitute material health risks. Any termination of the Agreement as provided under the provisions of this Section 6(g) shall relieve both parties of any further obligations under this Agreement (except provisions which indicate they survive termination), although Licensee shall continue to be responsible for any breach of any obligations which occurred prior to the date of such termination. Upon such termination pursuant to this section 6(g), Licensee shall as soon as reasonably practicable thereafter return the Premises to the condition in which it existed prior to

the Commencement Date, reasonable wear and tear and loss beyond Licensee's control excepted, unless District agrees in writing that the Premises can remain in its present condition.

(h) In addition, at the termination of this Agreement, and except for circumstances associated with Licensor's default, Licensee shall, at Licensee's sole cost and expense, return the Premises to the condition in which it existed prior to the execution of the Agreement, reasonable wear and tear and loss beyond Licensee's control excepted. If Licensee does not return the Premises to the condition which existed prior to Licensee's control, District may return the Premises to such condition and Licensee shall reimburse District for all of its costs.

7. **INSURANCE.** Licensee will carry during the Term, at its own cost and expense, the following insurance: (i) "All Risk" property insurance for its property's replacement cost; (ii) commercial general liability insurance with a minimum limit of liability of Two Million Dollars (\$2,000,000.00) combined single limit for bodily injury or death/property damage arising out of any one occurrence; (iii) Workers' Compensation Insurance as required by law; and (iv) Automobile Liability with combined single limit of One Million Dollars (\$1,000,000.00) per accident. Such limits may be satisfied by a combination of primary and umbrella policies. The coverage afforded by Licensee's commercial general liability insurance shall apply to Licensor as an additional insured. Licensee's policy shall be primary and any insurance of Licensor's shall be in excess of Licensee's insurance and shall not contribute to it, unless the underlying cause of the claim is caused by Licensor in which case Licensor's insurance shall be primary. Licensee's insurance shall not be canceled or reduced in coverage or in limits during the Term of this Agreement. Licensee shall provide a certificate of insurance and Additional Insured Endorsements to Licensor as of the time of the tender of the consideration as set forth in paragraph 4(a) above.

8. **INTERFERENCE.**

(a) Where there are existing radio frequency user(s) on the Property, the Licensor will provide Licensee with a list of all existing radio frequency user(s) on the Property to allow Licensee to evaluate the potential for interference. Licensee warrants that its use of the Premises will not interfere with existing radio frequency user(s) on the Property so disclosed by Licensor as of the Effective Date, as long as the existing radio frequency user(s) operate and continue to operate within their respective frequencies and in accordance with all applicable laws and regulations. In the event that measurable interference with existing radio frequency occurs, Licensor agrees to take all reasonable action necessary to eliminate such interference, in a reasonable time period. Licensee shall not interfere with Licensor's school programs or activities on the Property and Licensee's Communication Facilities and operations shall comply with all non-interference rules of the Federal Communications Commission ("FCC"). Licensee may terminate this Agreement as set forth in paragraph 6 above if Licensor fails to comply with this paragraph and/or pursue any other remedies available under this Agreement.

(b) Licensor reserves the right to grant, after the date of this Agreement, a lease, license or other right to a third party for the use of the Property, so long as such use does not measurably adversely affect or interfere with the Communication Facility, the operations of Licensee or the rights of Licensee under this Agreement. Licensor warrants to the best of its ability, that any third party licensee will engage in acts or omissions consistent with the business or educational interests of Licensor as a California public school district. Licensor will notify Licensee in writing prior to granting any third party the right to install and operate communications equipment on the Property.

(c) Licensor will not use, nor will Licensor permit its employees, tenants, licensees, invitees or agents to use, any portion of the Property in any way which measurably interferes with the Communication Facility, the operations of Licensee or the rights of Licensee under this

Agreement. Licensor will cause such interference to cease within a reasonable time period after receipt of notice of interference from Licensee, and in no case less than three (3) business days after said notification. In the event any such interference does not cease within the aforementioned time period, Licensee may terminate this Agreement as set forth in paragraph 6 above, in addition to any other rights that it may have at law or in equity, upon notice to Licensor.

(d) Licensee shall comply with all present and future laws, orders and regulations relating to Electromagnetic Fields ("EMF") and Radio-Frequencies ("RF"), including, but not limited to, the standards set by the American National Standards Institute ("ANSI") and FCC and all other local, State and Federal laws, rules, regulations and ordinances applicable to the subject matter of this License Agreement. (The FCC's new RF emission standards went into effect on October 15, 1997. Said standards are set forth in Section 1.1307 et seq. of the FCC Rules and in a related advisory document, "Evaluating Compliance with the FCC Guidelines for Human Exposure to Radio Frequency Electromagnetic Fields," OET Bulletin 65, Edition 97-01, issued August 25, 1997). Notwithstanding anything to the contrary contained in this License Agreement, it is Licensee's responsibility to make sure Licensee's employees and agents are informed of and comply with these FCC standards when conducting any work on or around the Property.

(e) Licensee shall be responsible for compliance with all tower and pole marking and lighting requirements of the Federal Aviation Administration ("FAA") and the FCC, provided it installs, owns and maintains the tower or pole. Should Licensee or Licensor be cited because the tower or pole is not in compliance, and should Licensee fail to cure the conditions of noncompliance within the time frame allowed by the citing agency, after notice of default and expiration of Licensee's period to cure, Licensor may, inter alia, terminate this License Agreement immediately on notice to Licensee or proceed to cure the conditions of noncompliance at Licensee's expense. Licensee shall indemnify and hold Licensor harmless from any fines or other liabilities caused by Licensee's failure to comply with such requirements and shall reimburse Licensor for all of its costs.

9. INDEMNIFICATION.

(a) Licensee agrees to indemnify, defend and hold Licensor harmless from and against any and all third party injury, loss, damage or liability (or any third party claims in respect of the foregoing), and any and all of Licensor's costs or expenses (including reasonable attorneys' fees and court costs), concerning any act or omission of Licensee relating to or arising under the Permitted Uses, any other uses of the Premises by Licensee, or the subject matter of this Agreement, except to the extent attributable to the negligence or intentional acts or omissions of Licensor, its employees, agents or independent contractors.

(b) Licensor agrees to indemnify, defend and hold Licensee harmless from and against any and all third party injury, loss, damage or liability (or any third party claims in respect of the foregoing), and any and all of Licensor's costs or expenses (including reasonable attorneys' fees and court costs), concerning any act or omission of Licensor relating to or arising under the Permitted Uses, any other uses of the Premises by Licensor, or the subject matter of this Agreement, except to the extent attributable to the negligence or intentional acts or omissions of Licensee, its employees, agents or independent contractors.

10. WARRANTIES.

(a) Licensee and Licensor each acknowledge and represent that it is duly organized, validly existing and in good standing and has the right, power and authority to enter into this Agreement and bind itself hereto through the party set forth as signatory for the party below.

(b) Licensor represents and warrants that: (i) Licensor solely owns the Property as a legal lot in fee simple, or controls the Property by lease or license; (ii) the Property is not encumbered by any liens, restrictions, mortgages, covenants, conditions, easements, leases, or any

other agreements of record or not of record, which would adversely affect Licensee's Permitted Use and enjoyment of the Premises under this Agreement; (iii) as long as Licensee is not in default then Licensor grants to Licensee sole, actual, quiet and peaceful use, enjoyment and possession of the Premises; (iv) to the best of Licensor's knowledge, Licensor's execution and performance of this Agreement will not violate any laws, ordinances or covenants, or the provisions of any lease or other agreement binding on the Licensor; and (v) if the Property is or becomes encumbered by a deed to secure a debt, mortgage or other security interest, Licensor will provide promptly to Licensee the name and contact information of such encumbrancer so Licensee may seek a mutually agreeable Subordination, Non-Disturbance and Attornment Agreement.

(c) Licensee represents and warrants that: (i) Licensee shall engage in lawful use of the Premises and for no other purpose; (ii) none of Licensee's acts or omissions on the Property shall cause injury, loss, damage or liability to any third party; (iii) none of Licensee's acts or omissions shall interfere with Licensor's duty to maintain a safe school environment for the pupils of the District; (iv) Licensee will not transport any Hazardous Material on to the Premises in violation of the law; and (v) to the best of Licensee's knowledge, Licensee's execution and performance of this Agreement will not violate any laws, ordinances or covenants, or the provisions of any lease or other agreement binding on the Licensee.

11. ENVIRONMENTAL.

(a) Licensor represents that to the best of Licensor's knowledge, the Premises is free of "Hazardous Materials," as defined in this paragraph, as of the date of this Agreement, *except as noted in the asbestos Hazard Emergency Response Act Report of February 16, 2004* and, to the best of Licensor's knowledge, the Premises has never been subject to any contamination or hazardous conditions resulting in any environmental investigation, inquiry or remediation. Licensor and Licensee agree that each will be responsible for compliance with any and all Hazardous Material laws, including any regulations, guidelines, standards, or policies of any governmental authorities regulating or imposing standards of liability or standards of conduct with regard to any Hazardous Material condition or other matters as may now or at any time hereafter be in effect, that are now or were related to that party's activity conducted in or on the Property. "Hazardous Material" shall mean petroleum or any petroleum product, asbestos, any substances known by the state in which the Property is located to cause cancer and/or reproductive toxicity, and/or any substance, chemical or waste that is identified as hazardous, toxic or dangerous in any applicable federal, state or local law or regulation. Within ten (10) days of the Effective Date of this Agreement, District will disclose and deliver to Licensee relevant reports and records in its possession related to Hazardous Materials on the Property.

(b) Licensor and Licensee agree to hold harmless, defend and indemnify the other from, and to assume all duties, responsibilities and liabilities at the sole cost and expense of the indemnifying party for, payment of penalties, sanctions, forfeitures, losses, costs or damages, and for responding to any action, notice, claim, order, summons, citation, directive, litigation, investigation or proceeding ("Claims") which is related to (i) the indemnifying party's failure to comply with any Hazardous Material law, including without limitation any regulations, guidelines, standards or policies of any governmental authorities regulating or imposing standards of liability or standards of conduct with regard to any Hazardous Material conditions or matters as may now or hereafter be in effect, or (ii) any Hazardous Material conditions to the extent that they are caused by the activities conducted by the party thereon, except for Hazardous Materials existing on the Property prior to the Commencement Date in which case Licensor shall indemnify, defend and hold Licensee harmless from any and all Claims. Licensor and Licensee agree, on a best efforts basis, to cooperate and assist in mitigating (i) and (ii) if they occur.

(c) The indemnifications of this Paragraph 11 Environmental specifically include reasonable costs, expenses and fees incurred in connection with any investigation of Property

conditions or any clean-up, remediation, removal or restoration work required by any governmental authority. The provisions of this Paragraph 11 Environmental will survive the expiration or termination of this Agreement.

(d) In the event Licensee becomes aware of any Hazardous Materials on the Property, or any Hazardous Material condition or matter relating to the Property that, in Licensee's sole determination, renders the condition of the Premises or Property unsuitable for Licensee's use, or if Licensee believes that the licensing or continued licensing of the Premises would expose Licensee to undue risks of government action, intervention or third-party liability, Licensee will have the right, in addition to any other rights it may have at law or in equity, to terminate the Agreement as set forth in paragraph 6 above. In the event that Licensee terminates the Agreement pursuant to this section, Licensee shall return the Premises to the condition in which it existed prior to the execution of the Agreement, reasonable wear and tear and casualty beyond Licensee's control excepted, unless District agrees in writing that the Premises remain in its present condition, taking into consideration the existence of Hazardous Materials when restoring the Premises. If Licensee does not return the Premises to the condition which existed on the Commencement Date, reasonable wear and tear and casualty beyond Licensee's control excepted, District may return the Premises to such condition and Licensee shall reimburse District for all of its costs.

12. **ACCESS.** At all times throughout the Term of this Agreement, and at no additional charge to Licensee, Licensee and its employees, agents, and subcontractors, will have pedestrian and vehicular access to and over the Property, solely for the installation, maintenance and operation of the Communication Facility and any utilities serving the Premises upon providing District with two (2) hour telephonic notice except in the case of an emergency, when Licensee shall be allowed access, provided that it notify the Licensor as soon as reasonably practicable thereafter. Licensor agrees to provide to Licensee such codes, keys and other instruments necessary for such access at no additional cost to Licensee. Licensor will provide access keys and codes for up to three Licensee designees. Licensee shall keep any codes, keys or other instruments necessary for such access confidential or secure as applicable. In the event any public utility is unable to use the access provided to Licensee then the Licensor agrees, to the extent it reasonably can, to grant additional access either to Licensee or to the public utility, for the benefit of Licensee, at no cost to Licensee.

13. **REMOVAL/RESTORATION.** All portions of the Communication Facility brought onto the Premises by Licensee will be and remains Licensee's personal property and, at Licensee's option, may be removed by Licensee at any time during the Term. Licensor covenants and agrees that no part of the Communication Facility constructed, erected or placed on the Premises by Licensee will become, or be considered as being affixed to or a part of, the Property, it being the specific intention of the Licensor that all improvements of every kind and nature constructed, erected or placed by Licensee on the Premises will be and remain the property of the Licensee and may be removed by Licensee at any time during the Term. At the earlier of the expiration or termination of this Agreement, Licensee will be responsible for the replacement of any trees, shrubs, or other vegetation if any are damaged by Licensee's removal, and Licensee will be required to remove from the Premises any foundations, underground utilities, or any part of the Communication Facility unless District agrees in writing to allow any such item to remain. If, upon termination or expiration, Licensee does not return the Premises to the condition which existed prior to the Commencement Date, reasonable wear and tear and casualty beyond Licensee's control excepted, District may return the Premises to such condition and Licensee shall reimburse District for all of its costs.

14. MAINTENANCE/UTILITIES.

(a) Licensee will keep and maintain the Premises in good condition, reasonable wear and tear and damage from the elements excepted. Licensor will maintain and repair the Property and access thereto, in good and tenantable condition, subject to reasonable wear and tear and damage from the elements. Licensee will remove graffiti within three (3) business days of notification.

(b) Licensee will be responsible for paying on a monthly or quarterly basis all utilities charges for electricity, telephone service or any other utility used or consumed by Licensee for utility access as set forth in Exhibit 1. Licensor will reasonably cooperate with any utility company requesting an access, under and across the Property in order for the utility company to provide service to the Licensee. Repair or maintenance of Licensee's utilities or Communications Facilities shall be subject to the access restrictions contained in Section 12 above. Licensor will not be responsible for interference with, interruption of or failure, beyond the reasonable control of Licensor, of such services to be furnished or supplied by Licensor.

15. TAXES. In the event that any property tax and/or assessments are levied on the Communications Facility, Licensee will be responsible for paying within thirty (30) days of receipt of reasonably sufficient documentation from Licensor all charges for these taxes and/or assessments which are attributable to Licensee's use and occupancy thereof. Notwithstanding anything contained herein to the contrary, Licensee's use of the Property under this License Agreement may be determined to create a "taxable possessory interest" in said Property and Licensee may be subject to the assessment of property taxes based upon such a possessory interest. As between the Licensor and the Licensee, Licensee shall be solely responsible for the payment of any and all such property taxes levied on such interest, including any penalties and interest in connection therewith. Licensor hereby grants Licensee the right to contest or challenge such taxes, whether in administrative proceeding or other venues on behalf of Licensor or Licensee, and to withhold payment of such taxes pending any such contest or challenge, if such withholding is permitted by the legal, equitable or administrative rules associated with such contest or challenge. Licensor agrees to provide timely notice of annual tax assessment to Licensee, sufficient to contest or challenge such assessment.

16. DEFAULT AND RIGHT TO CURE.

(a) In addition to other provisions in this Agreement setting forth breaches, the following will be deemed a default by Licensee and a breach of this Agreement: (i) non-payment of Rent if such Rent remains unpaid for more than twenty (20) days after Licensee's receipt of written notice from Licensor of such failure to pay; or (ii) Licensee's failure to perform any other term or condition under this Agreement within thirty (30) days after receipt of written notice from Licensor specifying the failure. No such failure, however, will be deemed to exist if Licensee has commenced to cure such default within such period and provided that such efforts are prosecuted to completion with reasonable diligence. Delay in curing a default will be excused if due to causes beyond the reasonable control of Licensee. If Licensee remains in default beyond any applicable cure period, Licensor will have the right to exercise any and all rights and remedies available to it under law and equity except where explicitly stated in this Agreement, including the right to cure Licensor's default and to deduct the costs of such cure from any monies due to Licensor from Licensee.

(b) The following will be deemed a default by Licensor and a breach of this Agreement: Licensor's failure to perform any term or condition under this Agreement within thirty (30) days after receipt of written notice from Licensee specifying the failure. No such failure, however, will be deemed to exist if Licensor has commenced to cure the default within such period and provided such efforts are prosecuted to completion with reasonable diligence. Delay in curing a default will be excused if due to causes beyond the reasonable control of

Licensor. If Licensor remains in default beyond any applicable cure period, Licensee will have the right to exercise any and all rights available to it under law and equity except where explicitly stated in this Agreement, including the right to cure Licensor's default and to deduct the costs of such cure from any monies due to Licensor from Licensee.

17. **ASSIGNMENT/SUB-LICENSE.** Licensee shall not have the right to assign this Agreement or sub-license the Premises and its rights herein, in whole or in part, provided however, Licensee may assign this Agreement upon written notice to Licensor, to any person controlling, controlled by, or under common control with Licensee, or any person or entity that acquires Licensee's radio communications business and assumes all obligations of Licensee under this Agreement. Upon such assignment, Licensee shall be relieved of all liabilities and obligations hereunder, provided that such assignee (i) has a net worth capable of maintaining the equipment and performing all obligations of this License (ii) does not engage in any activity which interferes with, or is otherwise incompatible with, Licensor's activities as a California public school district and provider of education services to minors, or which otherwise violates any Federal, State or local law or ordinance, and (iii) affirmatively provides a writing to Licensor indicating that such assignee accepts all duties and obligations under this Agreement on behalf of assignee.

18. **NOTICES.** All notices, requests, demands and communications hereunder will be given by first class certified or registered mail, return receipt requested, or by a nationally recognized overnight courier, postage prepaid, to be effective when properly sent and received. Notices will be addressed to the parties as follows:

If to Licensee: T-Mobile USA, Inc.
12920 SE 38th Street
Bellevue, WA 98006
Attn: PCS Lease Administrator
With a copy to: Attn: Legal Dept.

With a copy to: T-Mobile West Corporation
2380-A Bisso Lane
Concord, CA 94520
Attn: Lease Administration Manager

And with a copy to: Attn: Legal Dept.

If to Licensor: Richard Nicoll, Interim Superintendent
Mt. Diablo Unified School District
1936 Carlotta Drive
Concord, CA 94519

With a copy to: Pete Pedersen, Assistant Superintendent
And with a copy to: Office of the General Counsel

Either party hereto may change the place for the giving of notice to it by thirty (30) days prior written notice to the other as provided herein.

19. **SEVERABILITY.** If any term or condition of this Agreement is found unenforceable, the remaining terms and conditions will remain binding upon the parties as though said unenforceable provision were not contained herein.

20. **CONDEMNATION.** In the event Licensor receives notification of any condemnation proceedings affecting the Property, Licensor will provide notice of the proceeding to Licensee within forty-eight (48) hours. If a condemning authority takes all of the Property, or a portion sufficient, in Licensee's sole determination, to render the Premises unsuitable for Licensee, this Agreement will terminate as of the date designated by Licensee's notice of termination hereunder. The parties will each be entitled to pursue their own separate awards in the condemnation proceeds, which for Licensee will include, where applicable, the value of its Communication Facility, moving expenses, prepaid Rent, and business dislocation expenses, provided that any award to Licensee will not diminish Licensor's recovery. Licensee will be entitled to reimbursement for any prepaid Rent on a pro-rata basis. In the event Licensee is required to vacate the Property pursuant to a condemnation action, Licensee shall remove and bear all costs associated with moving the Communications Facility from the Premises, and shall return the Premises to the condition that existed on the Rent Commencement Date, reasonably taking into account the casualty and wear and tear, the repairs for which Licensee shall not be responsible. If, upon condemnation, Licensee does not return the Premises to the condition which existed prior to the Commencement Date, reasonable wear and tear and casualty beyond Licensee's control excepted, District may return the Premises to such condition and Licensee shall reimburse District for all of its costs.

21. **CASUALTY.** Licensor will provide notice to Licensee of any casualty affecting the Property within forty-eight (48) hours of the casualty. If any part of the Communication Facility or Property is damaged by fire or other casualty so as to render the Premises unsuitable, in Licensee's sole determination, then Licensee may terminate this Agreement by providing written notice to the Licensor, which termination will be effective as of the date of such damage or destruction. Upon such termination, Licensee will be entitled to collect all insurance proceeds payable to Licensee on account thereof and to be reimbursed for any prepaid Rent on a pro-rata basis. In the event that Licensee terminates this Agreement pursuant to this provision, Licensee shall remove and bear all costs associated with moving the Communications Facility from the Premises, and shall return the Premises to the condition that existed on the Rent Commencement Date, reasonably taking into account the casualty, the repairs for which Licensee shall not be responsible.

22. **WAIVER OF LICENSOR'S LIENS.** Licensor waives any and all lien rights it may have, statutory or otherwise, concerning the Communication Facility or any portion thereof. The Communication Facility shall be deemed personal property for purposes of this Agreement, regardless of whether any portion is deemed real or personal property under applicable law, and Licensor consents to Licensee's right to remove all or any portion of the Communication Facility from time to time in Licensee's sole discretion and without Licensor's consent.

23. **MISCELLANEOUS.**

(a) **Amendment/Waiver.** This Agreement cannot be amended, modified or revised unless done in writing and signed by an authorized agent of the Licensor and an authorized agent of the Licensee. No provision may be waived except in a writing signed by both parties.

(b) **Memorandum/Short Form License.** Either party will, at any time upon fifteen (15) business days prior written notice from the other, execute, acknowledge and deliver to the other a recordable Memorandum of License. Either party may record this Memorandum of License at any time, in its absolute discretion. Any such Memorandum of License may assert the existence of this Agreement, but shall not disclose the financial terms and conditions of this Agreement.

(c) **Bind and Benefit.** The terms and conditions contained in this Agreement will run with the Property and bind and inure to the benefit of the parties, their respective heirs, executors, administrators, successors and assigns.

(d) **Entire Agreement.** This Agreement and the exhibits attached hereto, all being a part hereof, constitute the entire agreement of the parties hereto and will supersede all prior offers, negotiations and agreements with respect to the subject matter of this Agreement.

(e) **Governing Law and Venue.** This Agreement will be governed by the laws of the state in which the Premises are located, without regard to conflicts of law. Venue shall be with the appropriate state or federal court located in Contra Costa County or in the Northern District of California, respectively.

(f) **Interpretation.** Unless otherwise specified, the following rules of construction and interpretation apply: (i) captions are for convenience and reference only and in no way define or limit the construction of the terms and conditions hereof; (ii) use of the term "including" will be interpreted to mean "including but not limited to"; (iii) whenever a party's consent is required under this Agreement, except as otherwise stated in the Agreement or as same may be duplicative, such consent will not be unreasonably withheld, conditioned or delayed; (iv) exhibits are an integral part of the Agreement and are incorporated by reference into this Agreement; (v) use of the terms "termination" or "expiration" are interchangeable; and (vi) reference to a default will take into consideration any applicable notice, grace and cure periods.

(g) **Estoppel.** Either party will, at any time upon twenty (20) business days prior written notice from the other, execute, acknowledge and deliver to the other a statement in writing (i) certifying that this Agreement is unmodified and in full force and effect (or, if modified, stating the nature of such modification and certifying this Agreement, as so modified, is in full force and effect) and the date to which the Rent and other charges are paid in advance, if any, and (ii) acknowledging that there are not, to such party's knowledge, any uncured defaults on the part of the other party hereunder, or specifying such defaults if any are claimed. Any such statement may be conclusively relied upon by any prospective purchaser or encumbrancer of the Premises. The requested party's failure to deliver such a statement within such time will be conclusively relied upon by the requesting party that (i) this Agreement is in full force and effect, without modification except as may be properly represented by the requesting party, (ii) there are no uncured defaults in either party's performance, and (iii) no more than one month's Rent has been paid in advance.

(h) **No Electronic Signatures/No Option.** The submission of this Agreement to any party for examination or consideration does not constitute an offer, reservation of or option for the Premises based on the terms set forth herein. This Agreement will become effective as a binding Agreement only upon the handwritten legal execution, acknowledgment and delivery hereof by Licensor and Licensee.

(i) **Subject to Approval of Board.** This Agreement confers no legal or equitable rights until it is approved by the District Board of Trustees at a lawfully conducted public meeting.

[SIGNATURES APPEAR ON THE NEXT PAGE]

IN WITNESS WHEREOF, the parties have caused this Agreement to be effective as of the last date written below.

"LICENSOR"

Mt. Diablo Unified School District, a
California public school district

By: _____

Print Name: _____

Its: _____

Date: _____

"LICENSEE"

T-Mobile West Corporation,
a Delaware corporation

By: _____

Print Name: Martin Vernon

Its: Director NorCal/San Francisco
Engineering and Operations

Date: _____

EXHIBIT 1
Communication Facility

GENERAL NOTES

1. DRAWINGS ARE NOT TO BE SCALED. WRITTEN DIMENSIONS TAKE PRECEDENCE, AND THIS SET OF PLANS IS INTENDED TO BE USED FOR DIAGRAMMATIC PURPOSES ONLY, UNLESS NOTED OTHERWISE. THE GENERAL CONTRACTOR'S SCOPE OF WORK SHALL INCLUDE FURNISHING ALL MATERIALS, EQUIPMENT, LABOR AND ANYTHING ELSE DEEMED NECESSARY TO COMPLETE INSTALLATIONS AS DESCRIBED HEREIN.
2. PRIOR TO THE SUBMISSION OF BOB, THE CONTRACTORS INVOLVED SHALL VISIT THE JOB SITE AND FAMILIARIZE THEMSELVES WITH ALL CONDITIONS AFFECTING THE PROPOSED PROJECT, WITH THE CONSTRUCTION AND CONTRACT DOCUMENTS. FIELD CONDITIONS AND CONFIRM THAT THE PROJECT MAY BE ACCOMPLISHED AS SHOWN PRIOR TO PROCEEDING WITH CONSTRUCTION. ANY ERRORS, OMISSIONS OR DISCREPANCIES ARE TO BE BROUGHT TO THE ATTENTION OF THE ARCHITECT/ENGINEER.
3. THE GENERAL CONTRACTOR SHALL RECEIVE WRITTEN AUTHORIZATION TO PROCEED WITH CONSTRUCTION PRIOR TO STARTING WORK ON ANY ITEM NOT CLEARLY DEFINED BY THE CONSTRUCTION DRAWINGS/CONTRACT DOCUMENTS.
4. THE CONTRACTOR SHALL SUPERVISE AND DIRECT THE PROJECT DESCRIBED HEREIN. THE CONTRACTOR SHALL BE SOLELY RESPONSIBLE FOR ALL CONSTRUCTION MEANS, METHODS, TECHNIQUES, SEQUENCES, AND PROCEDURES AND FOR COORDINATING ALL PORTIONS OF THE WORK UNDER THE CONTRACT.
5. THE CONTRACTOR SHALL INSTALL ALL EQUIPMENT AND MATERIALS ACCORDING TO MANUFACTURER'S/VENDOR'S SPECIFICATIONS UNLESS NOTED OTHERWISE OR WHERE LOCAL CODES OR ORDINANCES TAKE PRECEDENCE.
6. ALL WORK PERFORMED ON PROJECT AND MATERIALS INSTALLED SHALL BE IN STRICT ACCORDANCE WITH ALL APPLICABLE CODES, REGULATIONS, AND ORDINANCES. CONTRACTOR SHALL OBEY ALL NOTICES AND COMPLY WITH ALL LAWS, ORDINANCES, RULES, REGULATIONS, AND LAWFUL ORDERS OF ANY PUBLIC AUTHORITY, MUNICIPAL AND UTILITY COMPANY SPECIFICATIONS, AND LOCAL AND STATE JURISDICTIONAL CODES BEARING ON THE PERFORMANCE OF THE WORK.
7. GENERAL CONTRACTOR SHALL PROVIDE AT THE PROJECT SITE A FULL SET OF CONSTRUCTION DOCUMENTS UPDATED WITH THE LATEST REVISIONS AND ADDENDUMS OR CLARIFICATIONS FOR THE USE BY ALL PERSONNEL INVOLVED WITH THE PROJECT.
8. THE STRUCTURAL COMPONENTS OF THIS PROJECT SITE/FACILITY ARE NOT TO BE ALTERED BY THIS CONSTRUCTION PROJECT UNLESS NOTED OTHERWISE.
9. DETAILS HEREIN ARE INTENDED TO SHOW END RESULT OF DESIGN. MINOR MODIFICATIONS MAY BE REQUIRED TO SUIT JOB CONDITIONS OR SITUATIONS, AND SUCH MODIFICATIONS SHALL BE INCLUDED AS PART OF THE SCOPE OF WORK.
10. SEAL PENETRATIONS THROUGH FIRE-RATED AREAS WITH U.L. LISTED OR FIRE MARSHAL APPROVED MATERIALS IF APPLICABLE TO THIS FACILITY AND OR PROJECT SITE.
11. THE CONTRACTOR SHALL MAKE NECESSARY PROVISIONS TO PROTECT EXISTING IMPROVEMENTS, EASEMENTS, PAVING, CURBING, ETC. DURING CONSTRUCTION. UPON COMPLETION OF WORK, CONTRACTOR SHALL REPAIR ANY DAMAGE THAT MAY HAVE OCCURRED DUE TO THE CONSTRUCTION ON OR ABOUT THE PROPERTY.
12. CONTRACTOR SHALL SEE TO IT THAT GENERAL WORK AREA IS KEPT CLEAN AND HAZARD FREE DURING CONSTRUCTION AND DISPOSE OF ALL DIRT, DEBRIS, RUBBISH AND REMOVE EQUIPMENT NOT SPECIFIED AS REMAINING ON THE PROPERTY. PREMISES SHALL BE LEFT IN CLEAN CONDITION AND FREE FROM PAINT SPOTS, DUST, OR SMUDGES OF ANY NATURE.
13. THE ARCHITECTS/ENGINEERS HAVE MADE EVERY EFFORT TO SET FORTH IN THE CONSTRUCTION AND CONTRACT DOCUMENTS THE COMPLETE SCOPE OF WORK. CONTRACTORS BIDDING THE JOB ARE NEVERTHELESS CAUTIONED THAT MINOR OMISSIONS OR ERRORS IN THE DRAWINGS AND OR SPECIFICATIONS SHALL NOT EXCUSE SAID CONTRACTOR FROM COMPLETING THE PROJECT AND IMPROVEMENTS IN ACCORDANCE WITH THE INTENT OF THESE DOCUMENTS. THE BIDDER SHALL BEAR THE RESPONSIBILITY OF NOTIFYING (IN WRITING) THE ARCHITECT/ENGINEER OF ANY CONFLICTS, ERRORS, OR OMISSIONS PRIOR TO THE SUBMISSION OF CONTRACTOR'S PROPOSAL. IN THE EVENT OF DISCREPANCIES THE CONTRACTOR SHALL PRICE THE MORE COSTLY OR EXTENSIVE WORK, UNLESS DIRECTED OTHERWISE.

DIRECTIONS

- FROM T-MOBILE OFFICE @ 1755 CREEKSIDE OAKS DRIVE, SACRAMENTO, CA 95833:
- 1: Start out going SOUTHWEST on CREEKSIDE OAKS DR toward CAPITAL PARK DR.
 - 2: Turn LEFT onto CAPITAL PARK DR.
 - 3: Turn LEFT onto NATHANS PARK DR.
 - 4: Turn RIGHT onto GARDEN HWY.
 - 5: Merge onto I-5 N/CA-99 N toward WOODLAND.
 - 6: Merge onto I-80 W via EXIT 522 toward SAN FRANCISCO.
 - 7: Merge onto I-80 S via EXIT 40 toward BENICIA/SAN JOSE.
 - 8: Merge onto CA-4 E via EXIT 53 toward ANTIOCH/PRITSBURG.
 - 9: Take the SAN MARCO BLVD exit toward BAY POINT.
 - 10: Turn LEFT onto SAN MARCO BLVD/WILLOW PASS RD. Continue to follow WILLOW PASS RD.
 - 11: Turn LEFT onto PORT CHICAGO HWY.
 - 12: Turn LEFT onto PACIFICA AVE.
 - 13: End at 205 PACIFICA AVE, on the LEFT.

T-Mobile

OMNIPOINT COMMUNICATIONS

1755 CREEKSIDE OAKS DRIVE #190, SACRAMENTO, CA 95833

BA51992 - RIVERVIEW MIDDLE SCHOOL
 205 PACIFICA AVENUE
 BAY POINT, CA 94565
 APN: 098-210-025

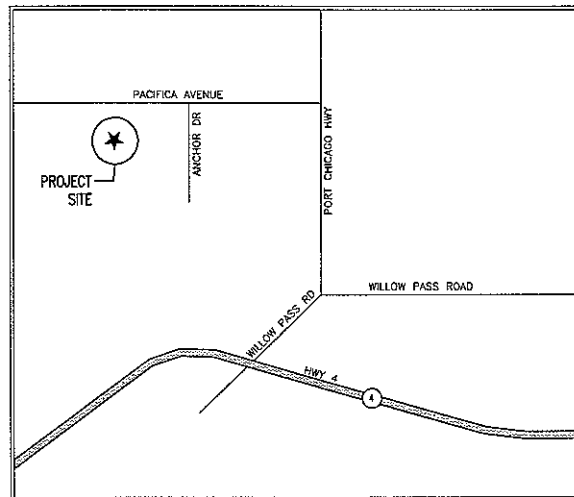

BAY POINT, CA

LOCATION PLAN

PROJECT DIRECTORY

| | |
|--|--|
| OWNER/APPLICANT T-MOBILE OMNIPOINT COMMUNICATIONS 1755 CREEKSIDE OAKS DR. #190 SACRAMENTO, CA 95833 | LANDLORD MOUNT Diablo UNITED SCHOOL DISTRICT 1936 CHARLOTTE DRIVE CONCORD, CA 94519 |
| ARCHITECT MARCEL S. TSHILAG MST ARCHITECTS, INC. 801 ALHAMBRA BLVD., SUITE 2 SACRAMENTO, CA 95816 916-505-3811 monu@mstarchitects.com | CONSTRUCTION MANAGER KARL LUBERSMIDT T-MOBILE 1755 CREEKSIDE OAKS DR. #190 SACRAMENTO, CA 95833 916-880-9229 |

APPROVALS

| | |
|---------------------------|-------------|
| LEASING: _____ | DATE: _____ |
| ZONING: _____ | DATE: _____ |
| RF ENGINEER: _____ | DATE: _____ |
| CONSTRUCTION: _____ | DATE: _____ |
| EQUIPMENT ENGINEER: _____ | DATE: _____ |
| OWNER: _____ | DATE: _____ |

PROJECT SUMMARY

PROPERTY INFORMATION
 LAT: N35° 01' 59.32" N40 83
 LONG: W121° 58' 06.10" N40 83
 ASSESSOR'S PARCEL NUMBER: 098-210-025
 JURISDICTION: CITY OF BAY POINT
 OCCUPANCE: S-2 (NON-HABITABLE EQUIPMENT) U (TOWER)
 TYPE OF CONSTRUCTION: TYPE V-B
 ZONING: RESIDENTIAL

CODE COMPLIANCE

ALL WORK AND MATERIALS SHALL BE PERFORMED AND INSTALLED IN ACCORDANCE WITH THE CURRENT EDITIONS OF THE FOLLOWING CODES AS ADOPTED BY THE LOCAL GOVERNING AUTHORITIES. NOTHING IN THESE PLANS IS TO BE CONSTRUED TO PERMIT WORK NOT CONFORMING TO THESE CODES:

1. CALIFORNIA ADMINISTRATIVE CODE (INCL. TITLE 24 & 25)
2. 2007 CALIFORNIA BUILDING CODE (CBC)
3. 2007 CALIFORNIA MECHANICAL CODE (CMC)
4. 2007 CALIFORNIA PLUMBING CODE (CPC)
5. 2007 CALIFORNIA ENERGY CODE (CEC)
6. 2007 CALIFORNIA ELECTRICAL CODE (CEC)
7. 2007 CALIFORNIA FIRE CODE (CFD)
8. LOCAL COUNTY OR CITY ORDINANCES

ACCESSIBILITY REQUIREMENTS:
 THIS FACILITY IS UNMANNED AND NOT FOR HUMAN HABITATION. HANDICAPPED ACCESS REQUIREMENTS ARE NOT REQUIRED IN ACCORDANCE WITH THE 2007 CALIFORNIA BUILDING CODE.

PROJECT DESCRIPTION

PROPOSED LAYOUT OF A T-MOBILE WIRELESS FACILITY IN A FENCED 20'-0" x 24'-0" LEASE AREA INCLUDING: (2) PROPOSED & (1) FUTURE T-MOBILE BTS EQUIPMENT CABINETS, POWER AND FIBER TO SITE, AND (3) ANTENNA SECTORS WITH (2) PROPOSED ANTENNAS PER SECTOR PLUS UNMOUNTED, VERTICALLY STACKED & CONCEALED WITHIN A 35'x FACIOME ON A NEW 70'-0" TALL T-MOBILE SUBLINE MONOPOLE.

PROJECT MILESTONES

| | |
|----------|-----------------------------|
| 07/21/09 | 90% ZONING DOCUMENTS |
| -- | 100% ZONING DOCUMENTS |
| -- | 90% CONSTRUCTION DOCUMENTS |
| -- | 100% CONSTRUCTION DOCUMENTS |

INDEX OF DRAWINGS

| | | |
|---|------|--|
| 1 | T1.1 | TITLE SHEET, LOCATION PLAN, PROJECT DATA |
| 2 | C.1 | CAN. SURVEY SHEET |
| 3 | A1.1 | EQUIPMENT LAYOUT PLANS |
| 4 | A1.2 | PROJECT ELEVATIONS |

MST ARCHITECTS
 801 ALHAMBRA BLVD., SUITE 2
 SACRAMENTO, CA 95816
 916-505-3811



BA51992 - RIVERVIEW MIDDLE SCHOOL
 205 PACIFICA AVENUE
 BAY POINT, CA 94565

T-Mobile
 OMNIPOINT COMMUNICATIONS
 SHEET TITLE: TITLE SHEET, LOCATION PLAN, PROJECT DATA

| |
|------------|
| Revisions: |
| △ -- |
| △ -- |
| △ -- |
| △ -- |
| △ -- |

File: 171108_1111.mxd
 Drawn: SP: ad
 Checked: BY: wst
 Scale: as NOTED
 Date: 07/21/09

Job No. 177128

T1.1

(1) 17191483

Exhibit 1 (2)

MST ARCHITECTS
 1700 Broadway, Suite 1000, San Francisco, CA 94133
 Tel: 415.774.1100
 Fax: 415.774.1101
 www.mstarchitects.com

Mobile
 EQUIPMENT LAYOUT PLANS
 SHEET TITLE: EQUIPMENT LAYOUT PLANS

| | |
|--------------|-----------|
| DATE: | 02/15/10 |
| SCALE: | AS SHOWN |
| DESIGNED BY: | MM |
| CHECKED BY: | MM |
| PROJECT NO.: | 10-000000 |

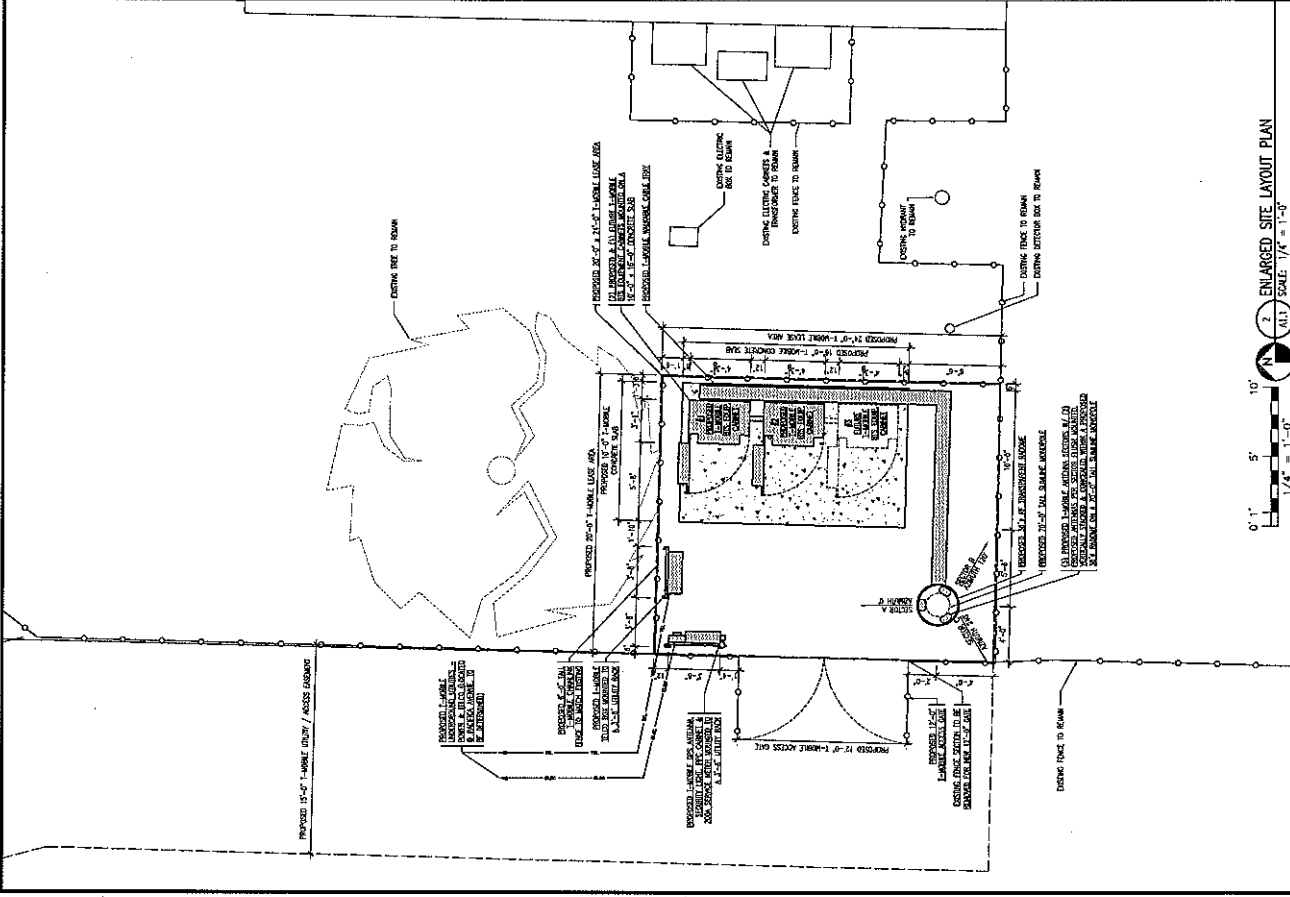
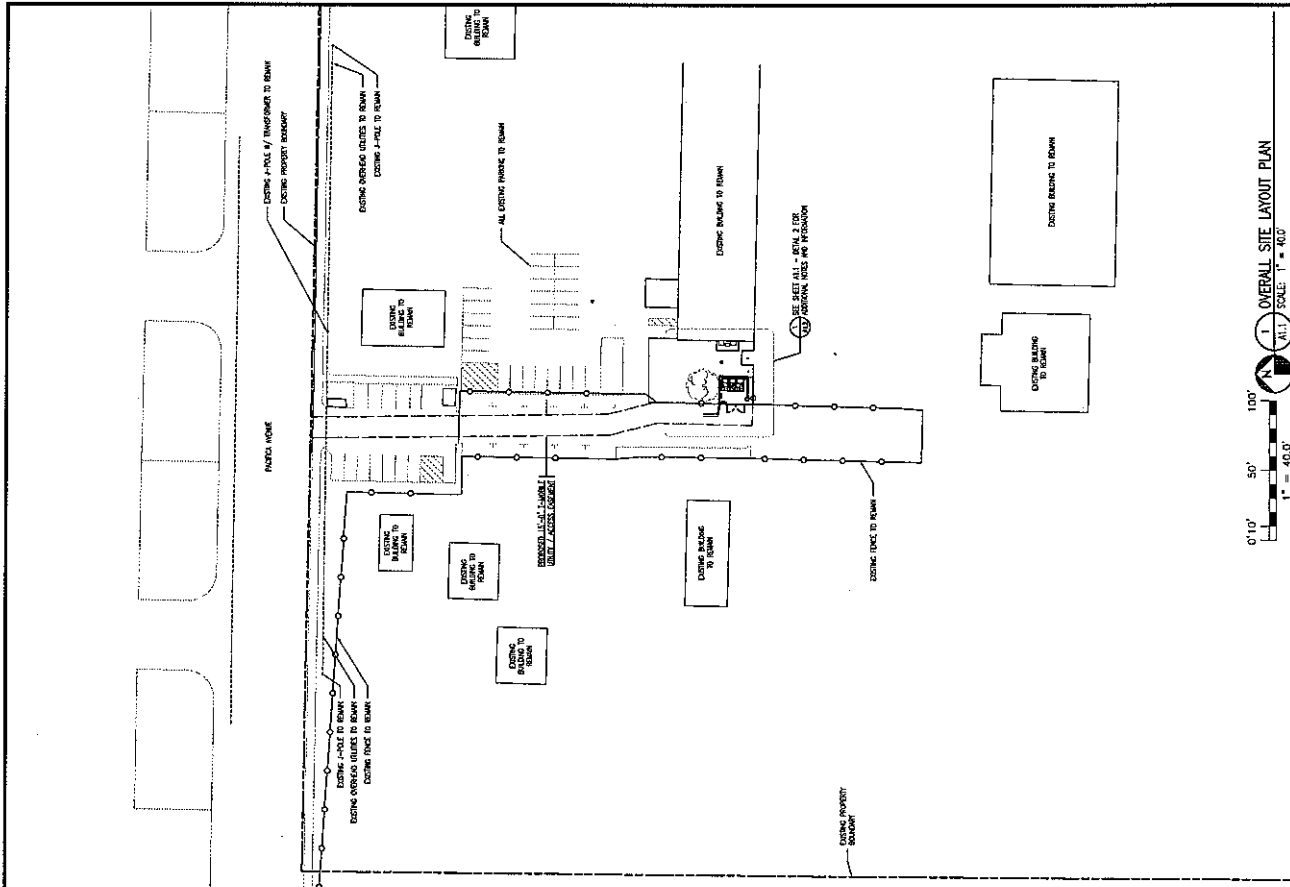

EXHIBIT 2

The location of the Premises within the Property (together with access and utilities) is more particularly described and depicted as follows:

However, it is expressly agreed and understood by and between the Licensor and Licensee that the exact and precise location of the Licensee's Communication Facilities are subject to review and approval by the planning and/or zoning boards having jurisdiction over the "Premises".

Therefore, it is expressly agreed and understood by and between and Licensee that the precise location of the Premises as shown on Exhibit "2" may be modified by the Licensee in order to comply with and obtain necessary planning and/or zoning approvals, and any and all other approvals necessary for Licensee's intended use of the property, with the understanding that the Premises will consist of approximately six hundred (600) square feet. The Premises as described herein may therefore be modified by the Licensee to reflect the final engineering design. An amended Exhibit "2" (if necessary) will be provided by the Licensee and attached to the license in place of the existing Exhibit "2", a copy of which will be provided to the Licensor for review prior to being incorporated into the license.

