

Mt. Diablo Unified School District

**Request For Qualifications and Proposals
MDUSD 1617**

**S-Wing
Modernization**

at

Mt. Diablo High School

Dated

April 24, 2013

Mt. Diablo Unified School District
2010 Measure C
3333 Ronald Way, Concord, CA 94519

April 24, 2013

REQUEST FOR QUALIFICATIONS AND PROPOSALS

S-Wing Renovation at Mt. Diablo High School

Mt. Diablo Unified School District invites responses from qualified firms, partnerships, corporations, associations, persons, or professional organizations to enter into agreements with the District for the **S-Wing Renovation at Mt. Diablo High School** ("Project").

The District intends to award this Project pursuant to a lease-leaseback structure (Education Code section 17406). Interested firms or persons are invited to submit their qualifications and proposal as described below, with one (1) original and five (5) copies of requested materials to:

Mt. Diablo Unified School District
2010 Measure C
3333 Ronald Way, Concord, CA 94519
Attn: Timothy M. Cody
(925) 682-8000 ext. 85615

Questions regarding this Request for Qualifications/Request for Proposals ("RFQ/RFP") may be directed to Timothy M. Cody at codyt@mdusd.org. Firms with questions or comments about the RFQ/RFP or the Project should not contact any other District representative, Board member, consultant, or employee, unless directed to do so by Mr. Cody.

All responses must be received by May 10, 2013, no later than 2:00 p.m.

This RFQ/RFP is not a formal request for bids or an offer by the District to contract with any party responding to this RFQ/RFP. The District reserves the right to reject any and all responses. The District also reserves the right to amend this RFQ/RFP as necessary.

I. General Information.

- A. Qualifications.** The District invites firms to submit qualifications related to their ability to provide development and construction services with respect to the construction of the Project described herein (“Firm”).
- B. Proposal.** In addition, the Firms shall provide a firm proposal to the District to perform the Project as indicated herein. The Firm selected as a result of this process may thereafter work cooperatively with the District Board, staff and consultants, the design team (if any), and the Project inspectors, to facilitate the timely completion of the Project.
- C. Criteria.** The District wishes to retain a Firm that has the financial strength, management and expertise to deliver the Project within the proposed schedule and within the established budget. The District reserves the right to choose any Firm. The Firm will be selected based on qualifications and demonstrated competence that include relevant experience with public school construction, experience with State of California school construction approval process, and a proven track record for cost-efficient and timely construction projects. A “best value” method of selection will be utilized. The “best value” method includes, but is not limited to, evaluating the following selection criteria (“Criteria”). The order listed does not imply order of importance.
1. Technical expertise;
 2. Firm experience and individual team member experience;
 3. Recent completion of projects through a lease-leaseback structure (Education Code section 17406);
 4. Recent completion of similar projects;
 5. Proximity of offices and availability of qualified staff;
 6. Prior positive experience with District staff and current consultants;
 7. Skilled labor force;
 8. Safety record;
 9. Constructability and value engineering expertise, experience, and approach;
 10. Experience with the type of product(s) requested and features similar to the Project;
 11. Logical and efficient methodology in technical approach to the Project;
 12. Ability to meet approved schedules;
 13. Anticipated charge for Project, including general conditions, fees and other costs;
 14. General responsiveness to this RFQ/RFP.
- D. Description of Project.** The Project for which the District is seeking responses is indicated in **Attachment “A,”** attached hereto.
- E. Project Architect.** The District’s architect of record for the Project is **Nacht and Lewis Architects** in Sacramento, California.
- F. Lease-Leaseback Structure**
1. **Education Code Section 17406.** The Project will be funded from various sources, and any agreement reached will conform to the statutory framework for the lease-leaseback delivery method (Education Code section 17406).
 2. **Potential Financing / Payments.**
 - (a) The Firm may be responsible for financing a portion of the construction of the Project.

(b) During construction, the District shall pay tenant improvement payments at a pre-determined payment amount. Once the Project is complete, the Firm shall lease the facilities constructed back to the District for a pre-determined monthly lease payment amount and lease period. The District intends the lease to include an early termination payment option for the District.

- G. Schedule.** The Project must be fully completed by the dates indicated in **Attachment “A-1”**.
- H. Project Estimates.** The current construction estimate for the Project is as indicated in **Attachment “A”**. The District expects significant cost reductions to be realized through cost cutting efforts with the Firm as described herein.
- I. District Provided Equipment and Materials.** As indicated in the contract documents.
- J. District Project Management Description.** The District’s 2010 Measure C Program Manager or his/her designee will be the primary point of contact between the Firm and the District.
- K. Diligence.** Submission of a proposal signifies careful examination of the Contract Documents and a complete understanding of the nature, extent, and location of Work to be performed. Firms submitting proposals must complete the tasks listed below as a condition to submitting a proposal, and submission of a proposal shall constitute the Firm’s express representation to District that the Firm has fully completed the following:
1. The Firm has visited the Project Site, if required, and has examined thoroughly and understood the nature and extent of the Contract Documents, Work, Site, locality, actual conditions, as-built conditions, and all local conditions and federal, state and local laws, and regulations that in any manner may affect cost, progress, performance, or furnishing of Work or that relate to any aspect of the means, methods, techniques, sequences, or procedures of construction to be employed by the Firm and safety precautions and programs incident thereto;
 2. The Firm has conducted or obtained and has understood all examinations, investigations, explorations, tests, reports, and studies that pertain to the subsurface conditions, as-built conditions, underground facilities, and all other physical conditions at or contiguous to the Site or otherwise that may affect the cost, progress, performance, or furnishing of Work, as the Firm considers necessary for the performance or furnishing of Work at the Guaranteed Project Cost, within the Contract Time, and in accordance with the other terms and conditions of Contract Documents, including specifically the provisions of the General Construction Provisions; and no additional examinations, investigations, explorations, tests, reports, studies, or similar information or data are or will be required by the Firm for such purpose;
 3. The Firm has correlated its knowledge and the results of all such observations, examinations, investigations, explorations, tests, reports, and studies with the terms and conditions of the Contract Document;
 4. The Firm has given the District prompt written notice of all conflicts, errors, ambiguities, or discrepancies that it has discovered in or among the Contract Documents and the actual conditions, and the written resolution thereof by the District is acceptable to the Firm;
 5. The Firm has made a complete disclosure in writing to the District of all facts bearing upon any possible interest, direct or indirect, that the Firm believes any representative of the District or other officer or employee of the District presently has or will have in this Contract or in the performance thereof or in any portion of the profits thereof;
 6. The Firm must, prior to submitting a proposal, perform the work, investigations, research, and analysis required by the Request for Qualifications and that the Firm represented in its proposal and the leases that it performed prior to submitting a proposal. The Firm is charged with all information and knowledge that a reasonable contractor would ascertain from having performed this required work, investigation, research, and analysis. Proposals must include entire cost of all work “incidental” to completion of the Work.
 7. Conditions shown on the Contract Documents: Information as to underground conditions, as-built conditions, or other conditions or obstructions, indicated in the Contract Documents, e.g., on

Drawings or in Specifications, has been obtained with reasonable care, and has been recorded in good faith. However, District only warrants, and the Firm may only rely, on the accuracy of limited types of information.

- L. As to above-ground conditions or as-built conditions shown or indicated in the Contract Documents, there is no warranty, express or implied, or any representation express or implied, that such information is correctly shown or indicated. This information is verifiable by independent investigation and the Firm is required to make such verification as a condition to submitting a proposal. In submitting its proposal, the Firm shall rely on the results of its own independent investigation. In submitting its proposal, the Firm shall not rely on District-supplied information regarding above-ground conditions or as-built condition.
- M. As to any subsurface condition shown or indicated in the Contract Documents, the Firm may rely only upon the general accuracy of actual reported depths, actual reported character of materials, actual reported soil types, actual reported water conditions, or actual obstructions shown or indicated. District is not responsible for the completeness of such information for preparing a proposal or construction; nor is District responsible in any way for any conclusions or opinions of the Firm drawn from such information; nor is District responsible for subsurface conditions that are not specifically shown (for example, District is not responsible for soil conditions in areas contiguous to areas where a subsurface condition is shown).
 - 1. Conditions Shown in Reports and Drawings Supplied for Informational Purposes: Reference is made to the document entitled Geotechnical Data, if exists, and the document entitled Existing Conditions, for identification of:
 - a. Subsurface Conditions: Those reports of explorations and tests of subsurface conditions at or contiguous to the Project Site that have been utilized by Architect in preparing the Contract Documents; and
 - b. Physical Conditions: Those drawings of physical conditions in or relating to existing surface or subsurface structures at or contiguous to the Project Site that has been utilized by Architect in preparing the Contract Documents.
- N. These reports and drawings are **not** Contract Documents and, except for any “technical” data regarding subsurface conditions specifically identified in Geotechnical Data and Existing Conditions, and underground facilities data, the Firm may not in any manner rely on the information in these reports and drawings. Subject to the foregoing, the Firm must make its own independent investigation of all conditions affecting the Work and must not rely on information provided by District

II. Submittal Requirements

All responses must be concise, well organized, and demonstrate the Firm’s qualifications. Responses shall follow the format outlined below. Responses shall be no longer than **50 pages (or 25 pages double-side)**, 8½” x 11” paper, inclusive of resumes, forms, and pictures, and tabbed according to the numbering system reflected below.

A. Cover Letter

B. Table of Contents

C. Firm Information

- 1. **General Information.** Provide the name, address, and a brief history of the Firm. Please include any former names of the Firm, the number of years the Firm has participated in construction as a general contractor, and current as well as past Contractors’ License Number. Include an organizational chart of the Firm.
- 2. **Personnel.** Provide resumes of personnel to be involved with the Project, including their school construction experience. Upon engagement, any change in personnel must be approved by the District. The Firm shall be responsible for any additional costs incurred by the engagement of a change in personnel.

3. **Past Project Values.** Provide the volume of completed construction in dollars for each of the past five (5) years and projects in progress.
 4. **Financials, Bonding & Insurance.** Provide a statement regarding financial resources, bonding capacity, and insurance coverage.
 5. **Claims Statement.** Provide a claims statement indicating any and all suits or claims in which the Firm or its personnel were parties and which related to construction projects within the past five (5) years. If a suit or claim was limited to a claim from a subcontractor to the Firm or a supplier to the Firm and did not include a project's owner, you need not include that suit or claim in your claims statement.
 6. **Contractor's License Information.** Provide the Firm's contractor license number and whether that license has been revoked or suspended in the past five (5) years.
 7. **Engineering / Architect License Information.** Provide the Firm's engineer and/or architect license number.
 8. **Firm Officers.** Provide signatory status of officer(s) of the Firm.
 9. **Local Office.** Provide the location of your local office nearest to the District, your main office if different, and other relevant resources of your Firm.
- D. Prior Relevant Experience.** The District prefers to contract with a Firm that has direct experience on projects of similar scope and structure, located in the geographic vicinity of the District.
1. **School Projects.** List **ALL** projects your Firm has been involved with for the past seven (7) years that satisfy the following factors:
 - (a) The project is located within approximately Fifty (50) miles of the District's administrative offices;
 - (b) The total project contract exceeds \$1,500,000;
 - (c) Multiple phased Projects at one single site: and
 - (d) The owner is a public school.

For these projects, provide a contact name and telephone number for the owners and indicate which key Firm personnel worked on each project.

Also, indicate whether the Firm performed its work under a lease-leaseback arrangement pursuant to Education Code section 17406, or other alternative delivery methods.
 2. **Complicated Projects.** As part of or in addition to your description of your Firm's past projects listed above, list projects your Firm has successfully completed that had some or all of the following obstacles, including the creative solutions from the Firm on how these obstacles were overcome:
 - (a) A very aggressive schedule;
 - (b) Significant budgetary restrictions.
 - (c) Be prepared to expand upon the following:
 - (i) What you did to accommodate the complexity of the project,
 - (ii) The needs of the clients on site,
 - (iii) Minimize inconveniences, and
 - (iv) Maximize safety.
 3. **Other Projects.** List other projects you would like the District to consider in its evaluation.
- E. Lease-Leaseback Agreement Forms.** Attached to this RFQ/RFP as **Attachment "B"** are forms

for the lease-leaseback agreement in substantially the form of the final lease-leaseback agreements. The District reserves the right to combine the leases for all projects into one lease-leaseback agreement or to separate them into separate leases for the site. The successful Firm shall be required to comply with the terms of these forms. Please provide any comments or objections to these forms, if any. **PLEASE NOTE:** The District will not consider any substantive changes to these forms if they are not submitted at this time.

- F. Architectural Drawings:** If applicable, provide a copy of Firm’s base-line architectural drawings. Additional drawings may be submitted if the Firm believes that the inclusion is necessary to fully describe ability to meet District design criteria. **Provide any additional documentation related to DSA approval and/or status thereof.**
- G. Proposal.** The District is requesting Firms to provide a firm proposal to perform the Project. Your pricing should be as detailed as possible, divided by scope. In addition, provide your Firm’s charges to the District for the following items. .
- 1. General Conditions:** List what is included in the Firm’s general conditions (including full-time and part-time personnel) and a monthly value of each item within the general conditions. Indicate what would be included as a cost of work vs. a line item in the general conditions.
 - (a)** You may list your general conditions as either a set monthly amount or a percentage of Project construction budget (hard) costs.
 - (b)** If applicable, provide a simplified cash flow to indicate reduced general conditions charges at different periods in the project.
 - (c)** The District will have the right to review and approve these items and costs.
 - 2. Mark-up on subcontractor work:** As a percentage of subcontract amounts. Provide a breakdown of actual mark-up or any information that will help the district evaluate this proposed item. List the name of all subcontractors to be utilized on the project.
 - 3. Mark-up on direct costs for self-performed work:** As a percentage of direct costs. Provide a breakdown of actual mark-up or any information that will help the district evaluate this proposed item.
 - 4. Fee:** If your Firm intends to charge a fee, overhead, profit, or similar charge in addition to the “mark-ups” indicated above, please state what that charge is, either as a set amount or a percentage of Project construction budget (hard) costs.
 - 5. Contingency:** Provide a line item for contingency of five percent (5%). This amount may be adjusted later. It shall be understood that any contingency is owned by the District and unused funds shall be returned to District upon completion.
 - 6. Other Costs:** Any other costs, fees, or a charge the Firm intends to charge the District to perform the work of the Project.
 - 7. Separate proposal for each site:** District requests separate proposal per this RFQ RFP. This proposal shall be comprehensive and include item G.1.

III. Public Records Act

Responses to this RFQ/RFP will become the property of the District and subject to the California Public Records Act, Government Code sections 6250, *et seq.* Those elements in each response that are trade secrets as that term is defined in Civil Code section 3426.1(d) or otherwise exempt by law from disclosure and which

are prominently marked as "TRADE SECRET," "CONFIDENTIAL," or "PROPRIETARY" may not be subject to disclosure. The District shall not be liable or responsible for the disclosure of any such records including, without limitation, those so marked if disclosure is deemed to be required by law or by an order of the Court. A Firm that indiscriminately identifies all or most of its response as exempt from disclosure without justification may be deemed non-responsive. In the event the District is required to defend an action on a Public Records Act request for any of the contents of a response marked "Confidential," "Proprietary," or "Trade Secret," the Firm agrees, by submission of its response for the District's consideration, to defend and indemnify the District from all costs and expenses, including attorneys' fees, in any action or liability arising under the Public Records Act.

IV. Districts' Evaluation and Selection Process

- A.** The District will review and evaluate all submitted documents received per this RFQ/RFP.
- B.** Responses will be opened privately to assure confidentiality and avoid disclosure of the contents to competing respondents prior to and during the review, evaluation and negotiation processes.
- C.** Responses will be reviewed for responsiveness and objectively evaluated pursuant to the Criteria.
- D.** After the responses are evaluated and/or ranked, the District, at its sole discretion, may elect to interview one or more Firms. Adequate time will be allowed for presentation of qualifications followed by questions and answers.
- E.** District staff will recommend one Firm (but reserves the right to recommend more than one Firm) to the District's Board that, in staff's opinion, is most qualified.
 - 1.** The District intends to first enter into a PSA with the successful Firm(s) as indicated herein.
 - 2.** District intends to then enter into the lease-leaseback agreement with the successful Firm.
 - 3.** If the District is unable to successfully negotiate a satisfactory agreement, at any time during this process, with terms and conditions the District determines to be fair and reasonable, the District may then commence negotiations with the next most qualified Firm in sequence until an agreement is reached or determination is made to reject all responses.
- F.** Final selection of a Firm, terms and conditions of any and all agreements and authority to proceed with noted construction services, shall be at the sole discretion of the District.

Attachment "A"

Preliminary Description of Project

**S-Wing Renovation at
Mt. Diablo High School ("Project")**

1. This District has estimated that the Project's construction budget (hard costs) is between **\$400,000 and \$500,000**, which already includes a contingency and escalation.
2. This Project, including equipment, occupancy and punch-list must be fully completed by **August 22, 2013**.
3. The Project is generally described as follows:
 - 3.1. Selective demolition and construction required to deliver a full and complete Campus Core Improvement Project, in accordance with documents prepared by Nacht and Lewis Architects, dated February 19, 2013.
 - 3.2. District provided equipment and materials, as indicated in contract documents, shall be included in this RFQ/RFP.
 - 3.3. The Project includes all utilities, including connection and integration to existing District infrastructure
 - 3.4. The Project is at Mt. Diablo High School, 2450 Grant Street, Concord, CA 94520
4. The Project must also comply with the District's technical specifications and drawings, as indicated in **Attachment "C" and "D"**, respectively.
5. **The details of the Project are subject to change**

Attachment "A-1"

Lease/Lease-Back Package 1617 Milestone Schedule

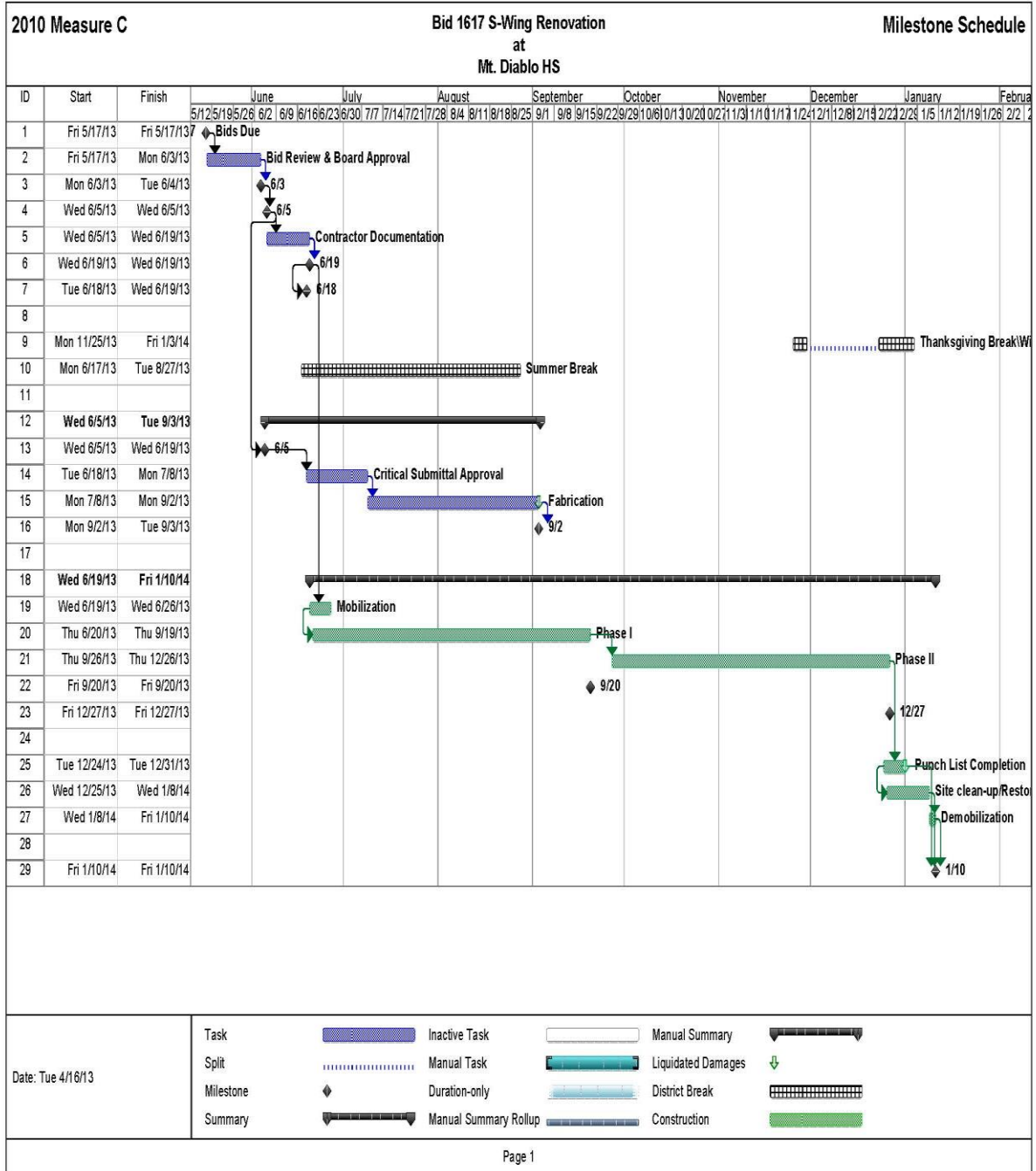

Attachment "B"
Lease-Leaseback Agreement Forms
RFQ 1617
See attachment
179 Page(s)

Attachment "C"

Technical Specifications

RFQ1617 Attachment C Technical Specs 02-19-13
(NLA, Inc. - Job Number Y1211.00
604 Page(s)

Attachment "D"

Plans

RFQ1617 Attachment D Plans 02-19-13

(NLA - Job Number Y1211.00

53 Page(s)

SITE LEASE

This site lease ("Site Lease") dated as of _____, 20__ ("Effective Date"), is made and entered into by and between the **Mount Diablo Unified School District**, a school district duly organized and validly existing under the laws of the State of California, as lessor ("District"), and _____, a California company duly organized and existing under the laws of the State of California, as lessee ("Developer") (together, the "Parties").

WHEREAS, the District currently owns a parcel of land located at **2450 Grant Street, Concord, CA 94520**, known as **Mt. Diablo High School**, and as more particularly described in **Exhibit A** attached hereto and incorporated herein by this reference ("School Site"); and

WHEREAS, the District desires to provide for the **S-Wing Modernization and appurtenant facilities to be performed on portions of the School Site** ("Project"); and

WHEREAS, the District determines that a portion of the School Site is adequate to accommodate the Project, as more particularly described in **Exhibit B** ("Project Site") attached hereto and incorporated herein by this reference; and

WHEREAS, District desires to have the construction of the Project completed and to lease it back, as more particularly described in the facilities lease between the Parties dated as of the Effective Date whereby the Developer agrees to lease the Project Site back to the District and perform the work of the Project ("Facilities Lease"), which Facilities Lease is incorporated herein by this reference; and

WHEREAS, the Board of Education of the District ("Board") has determined that it is in the best interests of the District and for the common benefit of the citizens residing in the District to construct the Project by leasing the Project Site to Developer and by immediately entering into the Facilities Lease under which District will lease back the Project from Developer; and

WHEREAS, the District further determines that it has entered into this Site Lease and the Facilities Lease pursuant to Education Code section 17406 as the best available and most expeditious means for the District to satisfy its substantial need for the facilities to be provided by the Project and to accommodate and educate District students; and

WHEREAS, the District is authorized under Education Code section 17406 to lease the Project Site to Developer and to have Developer develop and cause the construction of the Project thereon and lease the Project Site back to the District by means of the Facilities Lease, and the Board has duly authorized the execution and delivery of this Site Lease in order to effectuate the foregoing, based upon a finding that it is in the best interest of the District to do so; and

WHEREAS, Developer as lessee is authorized and competent to lease the Project Site from District and to develop and cause the construction of the Project on the Project Site, and has duly authorized the execution and delivery of this Site Lease; and

WHEREAS, the Parties have performed all acts, conditions and things required by law to exist, to have happened, and to have been performed prior to and in connection with the execution and entering into this Site Lease, and those conditions precedent do exist, have happened, and have been performed in regular and due time, form, and manner as required by law, and the Parties hereto are now duly authorized to execute and enter into this Site Lease;

NOW, THEREFORE, in consideration of the promises and of the mutual agreements and covenants contained herein, and other valuable consideration, the receipt and sufficiency of which is hereby acknowledged, the Parties hereto do hereby agree as follows:

1. **Definitions.** Unless the context clearly otherwise requires, all words and phrases defined in the Facilities Lease shall have the same meaning in this Site Lease.
2. **Exhibits.** The following Exhibits are attached to and by reference incorporated and made a part of this Site Lease.
 - 2.1. **Exhibit A:** Description of School Site
 - 2.2. **Exhibit B:** Description of Project Site
3. **Lease of the Project Site.** The District hereby leases to the Developer, and the Developer hereby leases from the District, the Project Site, subject only to Permitted Encumbrances, in accordance with the provisions of this Site Lease, to have and to hold for the term of this Site Lease. This Site Lease shall only take effect if the Facilities Lease is executed by the District and Developer within three (3) days of execution of this Site Lease.
4. **Leaseback of the Project Site.** The Parties agree that the Project Site will be leased back to the District pursuant to the Facilities Lease for the term thereof.
5. **Term.** The term of this Site Lease shall commence as of the Effective Date and shall terminate on the last day of the Term of the Facilities Lease, provided the District has paid to the Developer, or its assignee, all payments which may be due under the Facilities Lease, and provided this Site Lease has not been terminated pursuant to the termination provisions of the Facilities Lease.
6. **Payment.** In consideration for the lease of the Project Site by the District to the Developer and for other good and valuable consideration, the Developer shall pay One Dollar (\$1.00) to the District upon execution of this Site Lease.
7. **Termination**
 - 7.1. **Termination Upon Purchase of Project.** If the District exercises its option to purchase the Project pursuant to the Facilities Lease, then this Site Lease shall terminate concurrently with the District's buy out and termination of the Facilities Lease.
 - 7.2. **Termination Due to Default by Developer.** If Developer defaults pursuant to the provision(s) of the Facilities Lease and the District terminates the Facilities Lease pursuant to the Facilities Lease provision(s) allowing termination, then the Developer shall be deemed to be in default of this Site Lease and this Site Lease shall also terminate at the same time as the Facilities Lease.
 - 7.3. **Termination Due to Default by District.** If District defaults pursuant to the provision(s) of the Facilities Lease, the Developer, or its assignee, will have the right, for the then remaining term of this Site Lease, to:
 - 7.3.1. Take possession of the Project Site;
 - 7.3.2. If it deems it appropriate, cause appraisal of the Project Site and a study of the then reasonable uses thereof; and
 - 7.3.3. Relet the Project Site.
8. **Title to School Site.** During the term of this Site Lease, the District shall hold fee title to the School Site, including the Project Site, and nothing in this Site Lease or the Facilities Lease shall change, in any way, the District's ownership interest in the School Site.
9. **Improvements.** Title to all improvements made on the Project Site during the term hereof shall be held, vest

and transfer pursuant to the terms of the Facilities Lease.

10. **No Merger.** The leaseback of the Project Site by the Developer to the District pursuant to the Facilities Lease shall not effect or result in a merger of the estates of the District in the Project Site, and the Developer shall continue to have a leasehold estate in the Project Site pursuant to this Site Lease throughout the term hereof.
11. **Right of Entry.** The District reserves the right for any of its duly authorized representatives to enter upon the Project Site at any reasonable time to inspect the same, provided the District follows all safety precautions required by the Developer.
12. **Quiet Enjoyment.** Subject to any rights the District may have under the Facilities Lease (in the absence of an Event of Default) to possession and enjoyment of the Project Site, the District hereby covenants and agrees that it will not take any action to prevent the Developer from having quiet and peaceable possession and enjoyment of the Project Site during the term hereof and will, at the request of the Developer, to the extent that it may lawfully do so, join in any legal action in which the Developer asserts its right to such possession and enjoyment.
13. **Waste.** The Developer agrees that at all times that it is in possession of the Project Site, it will not commit, suffer or permit any waste on the Project Site, and that it will not willfully or knowingly use or permit the use of the Project Site for any illegal purpose or act.
14. **Further Assurances and Corrective Instruments.** The Parties shall, from time to time, execute, acknowledge and deliver, or cause to be executed, acknowledged and delivered, such supplements hereto and such further instruments as may reasonably be required for correcting any inadequate or incorrect description of the Project Site hereby leased or intended so to be or for carrying out the expressed intention of this Site Lease and the Facilities Lease.
15. **Representations of the District.** The District represents, covenants and warrants to the Developer as follows:
 - 15.1. **Due Organization and Existence.** The District is a school district, duly organized and existing under the Constitution and laws of the State of California.
 - 15.2. **Authorization.** The District has the full power and authority to enter into, to execute and to deliver this Site Lease, and to perform all of its duties and obligations hereunder, and has duly authorized the execution of this Site Lease.
 - 15.3. **No Violations.** To the best of the District's actual knowledge, neither the execution and delivery of this Site Lease nor the Facilities Lease, nor the fulfillment of or compliance with the terms and conditions hereof or thereof, nor the consummation of the transactions contemplated hereby or thereby, conflicts with or results in a breach of the terms, conditions or provisions of any restriction or any agreement or instrument to which the District is now a party or by which the District is bound, or constitutes a default under any of the foregoing, or results in the creation or imposition of any lien, charge or encumbrance whatsoever upon any of the property or assets of the District, or upon the Project Site, except Permitted Encumbrances.
 - 15.4. **CEQA Compliance.** The District has complied with all requirements imposed upon it by the California Environmental Quality Act (Public Resource Code Section 21000 *et seq.* ("CEQA")) in connection with the Project, and no further environmental review of the project is necessary pursuant to CEQA before the construction of the Project may commence.
 - 15.5. **No Litigation.** To the best of the District's actual knowledge, there is no pending or, to the knowledge of District, threatened action or proceeding before any court or federal, state, municipal, or other government authority or administrative agency which will materially adversely affect the ability of District to perform its obligations under this Site Lease.

15.6. Condemnation Proceedings.

15.6.1. District covenants and agrees, but only to the extent that it may lawfully do so, that so long as this Site Lease remains in effect, the District will not seek to exercise the power of eminent domain with respect to the Project so as to cause a full or partial termination of this Site Lease and the Facilities Lease.

15.6.2. If for any reason the foregoing covenant is determined to be unenforceable or in some way invalid, or if District should fail or refuse to abide by such covenant, then, to the extent they may lawfully do so, the Parties agree that the financial interest of Developer shall be as indicated in the Facilities Lease.

15.7. Use and Zoning. To the best of the District's actual knowledge, the Project Site is properly zoned for its intended purpose and the use or activities contemplated by this Site Lease will not conflict with local, state or federal law.

15.8. Taxes. To the best of the District's actual knowledge, all taxes and assessments are paid current and such taxes and assessments will continue to be paid to the extent that the District is not exempt.

15.9. Hazardous Materials. District is not currently aware of any contamination to the Project Site by Hazardous Materials, except for Hazardous Materials of which District has already informed Developer. If District becomes aware of any act or circumstance which would change or render this representation incorrect, in whole or in part, District will give immediate written notice of such changed fact or circumstance to Developer.

16. Representations of the Developer. The Developer represents, covenants and warrants to the District as follows:

16.1. Due Organization and Existence. The Developer is a California corporation licensed to provide such services in the state of California, has power to enter into this Site Lease and the Facilities Lease; is possessed of full power to lease, leaseback, and hold real and personal property and has duly authorized the execution and delivery of all of the aforesaid agreements.

16.2. Authorization. The Developer has the full power and authority to enter into, to execute and to deliver this Site Lease, and to perform all of its duties and obligations hereunder, and has duly authorized the execution of this Site Lease.

16.3. No Violations. Neither the execution and delivery of this Site Lease or the Facilities Lease, nor the fulfillment of or compliance with the terms and conditions hereof or thereof, nor the consummation of the transactions contemplated hereby or thereby, conflicts with or results in a breach of the terms, conditions or provisions of any restriction or any agreement or instrument to which the Developer is now a party or by which the Developer is bound, or constitutes a default under any of the foregoing, or results in the creation or imposition of any lien, charge or encumbrance whatsoever upon any of the property or assets of the Developer, or upon the Project Site, except for Permitted Encumbrances.

16.4. No Bankruptcy. Developer is not now nor has it ever been in bankruptcy or receivership.

16.5. No Litigation. There is no pending or, to the knowledge of Developer, threatened action or proceeding before any court or administrative agency which will materially adversely affect the ability of Developer to perform its obligations under this Site Lease or the Facilities Lease.

17. Insurance and Indemnity. The Developer and the District shall comply with the insurance requirements and

22. **Binding Effect.** This Site Lease shall inure to the benefit of and shall be binding upon the Developer and the District and their respective successors and assigns.
23. **No Additional Waiver Implied by One Waiver.** In the event any agreement contained in this Site Lease should be breached by either party and thereafter waived by the other party, such waiver shall be limited to the particular breach so waived and shall not be deemed to waive future compliance with any term hereof or any other breach hereunder.
24. **Severability.** In the event any provision of this Site Lease shall be held invalid or unenforceable by any court of competent jurisdiction, such holding shall not invalidate or render unenforceable any other provision hereof, unless elimination of such invalid provision materially alters the rights and obligations embodied in this Site Lease or the Facilities Lease.
25. **Amendments, Changes and Modifications.** Except as to the termination rights of both Parties as indicated in the Facilities Lease, this Site Lease may not be amended, changed, modified, altered or terminated without the written agreement of both Parties hereto.
26. **Obligations Absolute.** The Developer agrees that the obligations of the Developer are absolute and unconditional and not subject to any charges or setoffs against the District whatsoever.
27. **Execution in Counterparts.** This Site Lease may be executed in several counterparts, each of which shall be an original and all of which shall constitute one and the same instrument.
28. **Developer and District Representatives.** Whenever under the provisions of this Site Lease approval by the Developer or the District is required, or the Developer or the District is required to take some action at the request of the other, such approval or such request shall be given for the Developer by the Developer Representative and for the District by the District Representative, and any party hereto shall be authorized to rely upon any such approval or request.
29. **Applicable Law.** This Site Lease shall be governed by and construed in accordance with the laws of the State of California, and venue shall be in the County within which the School Site is located.
30. **Attorney's Fees.** If either party brings an action or proceeding involving the School Site or to enforce the terms of this Site Lease or to declare rights hereunder, each party shall bear the cost of its own attorneys' fees.
31. **Captions.** The captions or headings in this Site Lease are for convenience only and in no way define, limit or describe the scope or intent of any provisions or sections of this Site Lease.
32. **Prior Agreements.** This Site Lease and the corresponding Facilities Lease collectively contain all of the agreements of the Parties hereto with respect to any matter covered or mentioned in this Site Lease and no prior agreements or understanding pertaining to any such matter shall be effective for any purpose.
33. **Further Assurances.** Parties shall promptly execute and deliver all documents and instruments reasonably requested to give effect to the provisions of this Site Lease.
34. **Recitals Incorporated.** The Recitals set forth at the beginning of this Site Lease are hereby incorporated into its terms and provisions by this reference.
35. **Time of the Essence.** Time is of the essence with respect to each of the terms, covenants, and conditions of this Site Lease.

36. Force Majeure. A party shall be excused from the performance of any obligation imposed in this Site Lease and the exhibits hereto for any period and to the extent that a party is prevented from performing such obligation, in whole or in part, as a result of delays caused by the other party or third parties, a governmental agency or entity, an act of God, war, terrorism, civil disturbance, forces of nature, fire, flood, earthquake, strikes or lockouts, and such nonperformance will not be a default hereunder or a grounds for termination of this Site Lease.

37. Interpretation. None of the Parties hereto, nor their respective counsel, shall be deemed the drafters of this Site Lease or the Facilities Lease for purposes of construing the provisions of each. The language in all parts of this Site Lease shall in all cases be construed according to its fair meaning, not strictly for or against any of the Parties hereto.

IN WITNESS WHEREOF, the Parties have caused this Site Lease to be executed by their respective officers who are duly authorized, as of the Effective Date.

ACCEPTED AND AGREED on the date indicated below:

Dated: _____, 20____

Dated: _____, 20____

Mount Diablo School District

_____, **Inc.**

By: _____

By: _____

Print Name: _____

Print Name: _____

Print Title: Superintendent

Print Title: _____

EXHIBIT A

DESCRIPTION OF SCHOOL SITE

Attached is the Legal Description for: Mt. Diablo High School, 2450 Grant Street, Concord, CA 94520

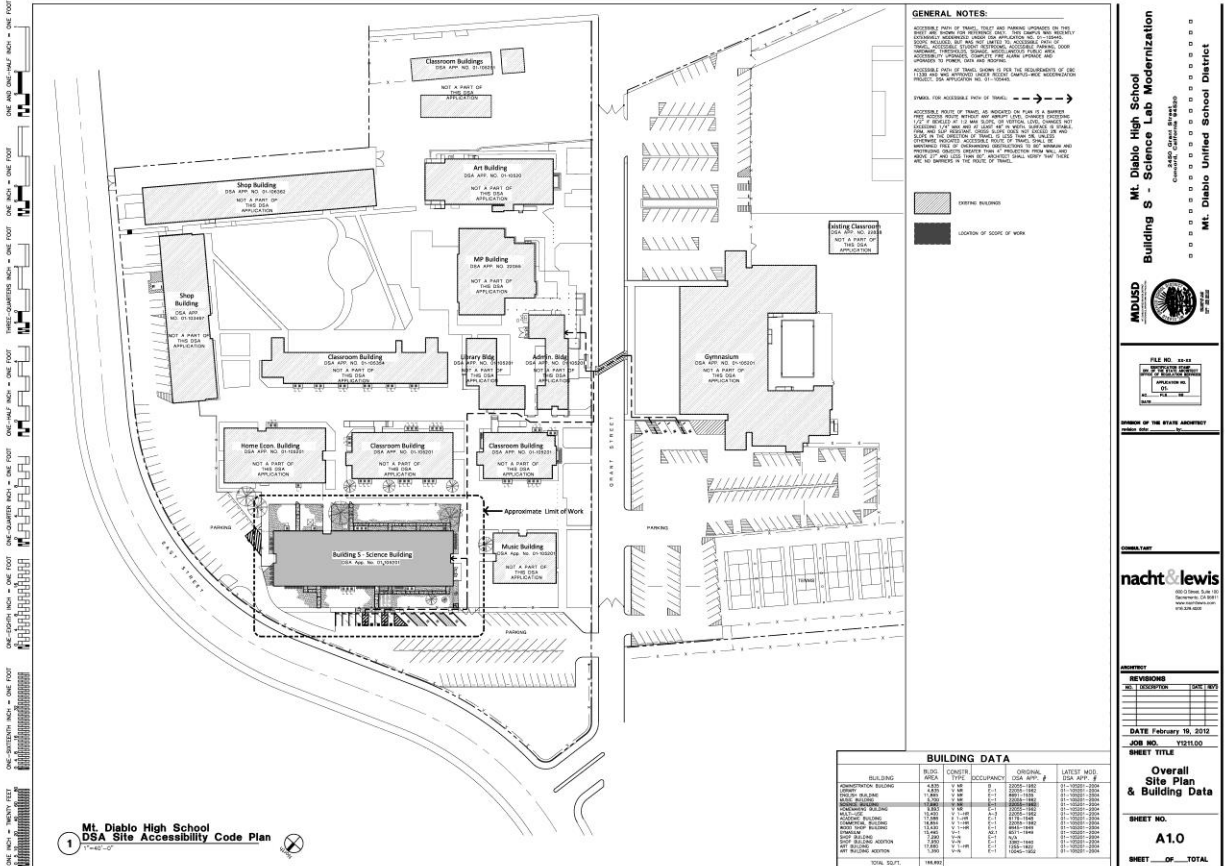

GENERAL NOTES:

ACCESSIBLE PORTS OF ENTRY, TRAVEL AND PARKING APPLICABLE TO THIS PROJECT ARE SHOWN ON THESE PLANS. THE WORK IS TO BE LIMITED TO THE EXISTING BUILDING AND NOT TO BE CONSIDERED AS A PART OF THE ACCESSIBLE PORTS OF ENTRY, TRAVEL AND PARKING. ACCESSIBLE PORTS OF ENTRY, TRAVEL AND PARKING ARE SHOWN IN THESE PLANS. ACCESSIBLE PORTS OF ENTRY, TRAVEL AND PARKING ARE SHOWN IN THESE PLANS. ACCESSIBLE PORTS OF ENTRY, TRAVEL AND PARKING ARE SHOWN IN THESE PLANS.

EXISTING BUILDING
LOCATION OF SCOPE OF WORK

BUILDING	AREA	TOTAL	ORIGINAL	LATEST MOD.
BUILDING	AREA	TOTAL	ORIGINAL	LATEST MOD.
ADMINISTRATIVE BUILDING	1,450	1,450	1,450	1,450
ART BUILDING	1,450	1,450	1,450	1,450
CLASSROOM BUILDING	1,450	1,450	1,450	1,450
HOME ECON BUILDING	1,450	1,450	1,450	1,450
SCIENCE BUILDING	1,450	1,450	1,450	1,450
SHOP BUILDING	1,450	1,450	1,450	1,450
TOTAL	1,450	1,450	1,450	1,450

MDUSD
Mt. Diablo High School
Building S - Science Lab Modernization
2450 Grant Street
Concord, California 94520
MT. Diablo Unified School District

FILE NO. 20-22
PROJECT CODE
DATE February 10, 2012
JOB NO. V2311.00
SHEET TITLE
Overall Site Plan & Building Data
SHEET NO. **A1.0**
SHEET OF TOTAL
DSA SUBMITTAL SET

EXHIBIT B

DESCRIPTION OF PROJECT SITE

Attached is the Legal Description for a portion of the School Site and Description of the Project that is subject to the Site Lease and the Facilities Lease and upon which Developer will construct the Project.
 Mt. Diablo High School, 2450 Grant Street, Concord, CA 94520

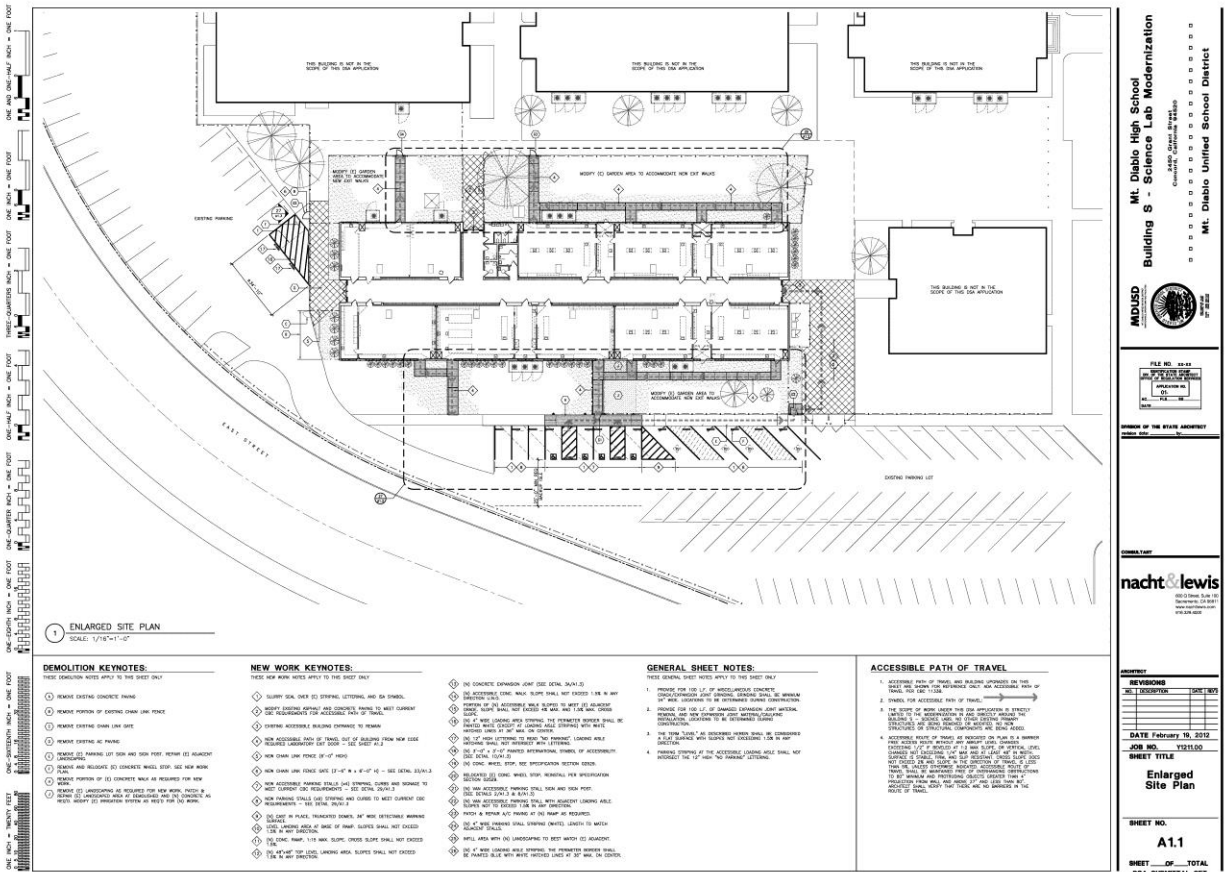

FACILITIES LEASE

This facilities lease ("Facilities Lease"), dated as of _____, 20__ ("Effective Date"), is made and entered into by and between and _____, a California company duly organized and existing under the laws of the State of California, as sublessor ("Developer"), and **Mount Diablo Unified School District**, a school district duly organized and validly existing under the laws of the State of California, as sublessee ("District") (together, the "Parties").

RECITALS

WHEREAS, the District currently owns a parcel of land located at **2450 Grant Street, Concord, CA 94520**, known as **Mt. Diablo High School**, and as more particularly described in **Exhibit A** attached hereto and incorporated herein by this reference ("School Site"); and

WHEREAS, the District desires to provide for the **S-Wing Renovation and appurtenant facilities to be performed on portions of the School Site.** That work will include related work as further indicated in **Exhibit B** (the "Project");

WHEREAS, the District determines that a portion of the School Site is adequate to accommodate the Project, as more particularly described in **Exhibit B** ("Project Site") attached hereto and incorporated herein by this reference; and

WHEREAS, District has retained **Nacht and Lewis Architects** ("Architect") to prepare plans and specifications for the Project ("Plans and Specifications") which are not required to be approved by the California Division of the State Architect ("DSA"); and

WHEREAS, District and Developer have executed a site lease at the same time as this Facilities Lease whereby the District is leasing the Project Site to the Developer ("Site Lease"); and

WHEREAS, Developer represents that it has the expertise and experience to perform the services set forth in this Facilities Lease; and

WHEREAS, the District is authorized under Section 17406 of the Education Code of the State of California to lease the Project Site to Developer and to have Developer develop and construct the Project on the Project Site and to lease back to the District the Project Site and the Project, and has duly authorized the execution and delivery of this Facilities Lease; and

WHEREAS, Developer is authorized to lease the Project Site as lessee and to develop the Project and to have the Project constructed on the Project Site and to lease the Project and the Project Site back to the District, and has duly authorized the execution and delivery of this Facilities Lease; and

WHEREAS, the Board of Education of the District (the "Board") has determined that it is in the best interests of the District and for the common benefit of the citizens residing in the District to construct the Project by leasing the Project Site to Developer and by simultaneously entering into this Facilities Lease under which the District will lease back the Project Site and the Project from Developer and if necessary, make Lease Payments as indicated in **Exhibit C** attached hereto and incorporated herein by reference); and

WHEREAS, the Parties have performed all acts, conditions and things required by law to exist, to have happened and to have been performed precedent to and in connection with the execution and entering into of this Facilities Lease and all those conditions precedent do exist, have happened and have been performed in regular and due time, form and manner as required by law, and the Parties hereto are now duly authorized to execute and enter into this Facilities Lease; and

WHEREAS, the District further acknowledges and agrees that it has entered into the Site Lease and the Facilities Lease pursuant to Education Code Section 17406 as the best available and most expeditious means for the District to satisfy its substantial need for the facilities to be provided by the Project and to accommodate and educate District students and to utilize its facilities proceeds expeditiously.

NOW, THEREFORE, in consideration of the above recitals and of the mutual covenants hereinafter contained, the Parties hereto do hereby agree as follows:

1. Definitions. In addition to the terms and entities defined above or subsequent provisions defined herein, and unless the context otherwise requires, the terms defined in this section shall, for all purposes of this Facilities Lease, have the meanings herein specified.

1.1. "Developer" or "Lessor" means _____, a California corporation, organized and existing under the laws of the State of California, and its successors and assigns.

1.2. "Developer's Representative" means the Managing Member of Developer, or any person authorized to act on behalf of Developer under or with respect to this Facilities Lease.

1.3. "Contract Documents" are defined in **Exhibit D** to this Facilities Lease.

1.4. "District" or "Lessee" means the **Mount Diablo Unified School District**, a school district duly organized and existing under the laws of the State of California.

1.5. "District Representative" means the Superintendent of the District, or any other person authorized by the Board of Trustees of the District to act on behalf of the District under or with respect to this Facilities Lease.

1.6. "Permitted Encumbrances" means, as of any particular time:

1.6.1. Liens for general and valorem taxes and assessments, if any, not then delinquent, or which the District may permit to remain unpaid;

1.6.2. The Project Site lease;

1.6.3. This Facilities Lease,

1.6.4. Easements, rights of way, mineral rights, drilling rights and other rights, reservations, covenants, conditions or restrictions which exist of record as of the date of this Facilities Lease.

1.6.5. Easements, rights of way, mineral rights, drilling rights and other rights, reservations, covenants, conditions or restrictions established following the date of recordation of this Facilities Lease and to which Developer and the District consent in writing which will not impair or impede the operation of the Project Site; and

2. Exhibits. The following Exhibits are attached to and by reference incorporated and made a part of this Facilities Lease:

2.1. Exhibit A: Description of the School Site: The descriptions of the real property constituting the School Site.

2.2. Exhibit B: Description of the Project Site and Description of the Project: The description of the Project Site and the Project.

2.3. Exhibit C: Guaranteed Project Cost and Other Project Cost, Funding, and Payment Provisions: A detailed description of the Guaranteed Project Cost and the provisions related to the payment of that amount to the Developer.

2.4. Exhibit D: General Construction Provisions: The provisions generally describing the Project's construction.

2.5. Exhibit E: Memorandum of Commencement Date: The Memorandum which will memorialize the commencement and expiration dates of the Term.

2.6. Exhibit F: Construction Schedule: Construction Schedule for the Project Site.

2.7. Exhibit G: Schedule of Values

2.8. Exhibit H: Agreement For Preliminary Services (If used)

2.9. Exhibit I: Certificates and Bonds to Lease-Leaseback Documents and Division 1 Documents to Lease-Leaseback Documents

2.10. Exhibit J: Plans, Technical Specifications, and Drawings

2.11. Exhibit K: Revisions to Contract Documents

3. Lease of Project and Project Site.

3.1. Developer hereby leases the Project and the Project Site to the District, and the District hereby leases said Project and Project Site from Developer upon the terms and conditions set forth in this Facilities Lease.

3.2. The leasing by Developer to the District of the Project Site shall not affect or result in a merger of the District's leasehold estate pursuant to this Facilities Lease and its fee estate as lessor under the Site Lease. Developer shall continue to have and hold a leasehold estate in the Project Site pursuant to the Site Lease throughout the term thereof and the term of this Facilities Lease.

3.3. As to the Project Site, this Facilities Lease shall be deemed and constitute a sublease.

3.4. Occupied School Site. The Developer acknowledges that portions the Project Site shall, at all times, be occupied by the District as an operating school. The Parties have agreed to a plan and process whereby the Developer's activities shall be kept separate from the operating school even though the operating school is within the Project site. The specifics of the plan and process are as indicated in **Exhibit K**.

3.5. Work During Instructional Time. Developer affirms that Work may be performed during ongoing instruction in existing facilities. If so, Developer agrees to cooperate to the best of its ability to minimize any disruption to the School Site up to, and including, rescheduling specific work activities, at no additional cost to the District.

3.6. No Work During Student Testing. Developer shall, at no additional cost to **the District** and at the District's request, coordinate its Work to not disturb District students including, without limitation, not performing any Work when students at the School Site are taking State-required tests. Refer to the testing schedule as indicated in **Exhibit K**.

4. Term.

4.1. Facilities Lease is Legally Binding. This Facilities Lease is legally binding on the Parties upon execution by the Parties and the District Board's approval of this Facilities Lease. The **Term** of this Facilities Lease for the purposes of District's obligation to make Lease Payments shall commence on the earlier of the following two (2) events ("Commencement Date") and shall terminate six (6) months after the Commencement Date (the "Term"):

- 4.1.1. The date the District takes beneficial occupancy of the Project; or
- 4.1.2. The date of Project Completion, as defined in **Exhibit D** to this Facilities Lease.

4.2. On the Commencement Date, the Parties shall execute the Memorandum of Commencement attached hereto as **Exhibit E** to memorialize the commencement and expiration dates of the Term. Notwithstanding this Term, the Parties hereby acknowledge that each has obligations, duties, and rights under this Facilities Lease that exist upon execution of this Facilities Lease and prior to the beginning of the Term.

4.3. The Term may be extended or shortened upon the occurrence of the earliest of any of the following events, which shall constitute the end of the Term:

- 4.3.1. An Event of Default by District as defined herein and Developer's election to terminate this Facilities Lease as permitted herein, or
- 4.3.2. An Event of Default by Developer as defined herein and District's election to terminate this Facilities Lease as permitted herein, or
- 4.3.3. Consummation of the District's purchase option pursuant to the Guaranteed Project Cost and Other Project Cost, Funding, and Payment Provisions indicated in **Exhibit C** ("Guaranteed Project Cost Provisions").
- 4.3.4. A third-party taking of the Project under Eminent Domain, only if the Term is ended as indicated more specifically herein.
- 4.3.5. Damage or destruction of the Project, only if the Term is ended as indicated more specifically herein.

5. Payment. In consideration for the lease of the Project Site by the Developer back to the District and for other good and valuable consideration, the District shall make the Tenant Improvements Payments and Lease Payments pursuant to the Guaranteed Project Cost Provisions indicated in **Exhibit C**.

6. Termination; Lease Terminable Only As Set Forth Herein.

6.1. Except as otherwise expressly provided in this Facilities Lease, this Facilities Lease shall not terminate, nor shall District have any right to terminate this Facilities Lease or be entitled to the abatement of any all necessary payments pursuant to the Guaranteed Project Cost Provisions indicated in **Exhibit C** or any reduction thereof. The obligations hereunder of District shall not be otherwise affected by reason of any damage to or destruction of all or any part of the Project; the taking of the Project or any portion thereof by condemnation or otherwise; the prohibition, limitation or restriction of District's use of the Project; the interference with such use by any private person or Developer; the District's acquisition of the ownership of the Project (other than pursuant to an express provision of this Facilities Lease); any present or future law to the contrary notwithstanding. It is the intention of the Parties hereto that all necessary payments pursuant to the Guaranteed Project Cost Provisions indicated in **Exhibit C** shall continue to be payable in all events, and the obligations of the District hereunder shall continue unaffected unless the requirement to pay or perform the same shall be terminated or modified pursuant to an express provision of this Facilities Lease.

6.2. Nothing contained herein shall be deemed a waiver by the District of any rights that it may have to bring a separate action with respect to any Event of Default by Developer hereunder or under any other agreement to recover the costs and expenses associated with that action. The District covenants and agrees that it will remain obligated under this Facilities Lease in accordance with its terms.

6.3. Following Project Completion, that the District will not take any action to terminate, rescind or avoid this Facilities Lease, notwithstanding the bankruptcy, insolvency, reorganization, composition, readjustment, liquidation, dissolution, winding-up or other proceeding affecting Developer or any assignee of Developer in any such proceeding, and notwithstanding any action with respect to this Facilities Lease which may be taken by any trustee or receiver of Developer or of any assignee of Developer in any such proceeding or by any court in any such proceeding. Following Project Completion, except as otherwise expressly provided in this Facilities Lease, District waives all rights now or hereafter conferred by law to quit, terminate or surrender this Facilities Lease or the Project or any part thereof.

6.4. District acknowledges that Developer may assign an interest in some or all of the necessary payments pursuant to the Guaranteed Project Cost Provisions indicated in **Exhibit C** to a lender in order to obtain financing for the cost of constructing the Project and that the lender may rely on the foregoing covenants and provisions in connection with such financing.

6.5. The District in its sole discretion may terminate for convenience this Facilities Lease upon three (3) days written notice to the Developer. In case of a termination for convenience, the Developer shall have no claims against the District except the actual portion of the Guaranteed Project Cost expended for labor, materials, and services performed that is unpaid and can be documented through timesheets, invoices, receipts, or otherwise, through the date of termination, plus necessary and reasonable documented demobilization costs.

7. Title.

7.1. During the Term of this Facilities Lease, the District shall hold fee title to the School Site, including the Project Site, and nothing in this Facilities Lease or the Site Lease shall change, in any way, the District's ownership interest.

7.2. During the Term of this Facilities Lease, Developer shall have a leasehold interest in the Project Site pursuant to the Site Lease.

7.3. During the Term of this Facilities Lease, the Developer shall hold title to the Project improvements provided by Developer which comprise fixtures, repairs, replacements or modifications thereto.

7.4. If the District exercises its Purchase Option pursuant the Guaranteed Project Cost Provisions indicated in **Exhibit C** or if District makes all necessary payments under the Guaranteed Project Cost Provisions indicated in **Exhibit C**, all right, title and interest of Developer, its assigns and successors in interest in and to the Project and the Project Site shall be transferred to and vested in the District at the end of the Term. Title shall be transferred to and vested in the District hereunder without the necessity for any further instrument of transfer; provided, however, that Developer agrees to execute any instrument requested by District to memorialize the termination of this Facilities Lease and transfer of title to the Project.

8. Quiet Enjoyment. Upon District's possession of the Project, Developer shall thereafter provide the District with quiet use and enjoyment of the Project, and the District shall during the Term peaceably and quietly have and hold and enjoy the Project, without suit, trouble or hindrance from Developer, except as otherwise may be set forth in this Facilities Lease. Developer will, at the request of the District and at Developer's cost, join in any legal action in which the District asserts its right to such possession and enjoyment to the extent Developer may lawfully

do so. Notwithstanding the foregoing, Developer shall have the right to inspect the Project and the Project Site as provided herein.

9. Representations of the District. The District represents, covenants and warrants to the Developer as follows:

9.1. Due Organization and Existence. The District is a school district, duly organized and existing under the Constitution and laws of the State of California.

9.2. Authorization. The District has the full power and authority to enter into, to execute and to deliver this Facilities Lease, and to perform all of its duties and obligations hereunder, and has duly authorized the execution of this Facilities Lease.

9.3. No Violations. Neither the execution and delivery of this Facilities Lease nor the Site Lease, nor the fulfillment of or compliance with the terms and conditions hereof or thereof, nor the consummation of the transactions contemplated hereby or thereby, conflicts with or results in a breach of the terms, conditions or provisions of any restriction or any agreement or instrument to which the District is now a party or by which the District is bound, or constitutes a default under any of the foregoing, or results in the creation or imposition of any lien, charge or encumbrance whatsoever upon any of the property or assets of the District, or upon the Project Site, except Permitted Encumbrances

9.4. CEQA Compliance. The District has complied with all requirements imposed upon it by the California Environmental Quality Act (Public Resource Code Section 21000 *et seq.* ("CEQA")) in connection with the Project, and no further environmental review of the project is necessary pursuant to CEQA before the construction of the Project may commence. Developer shall comply will all applicable mitigation measures, if any, adopted by any public agency with respect to this Project pursuant to the California Environmental Quality Act. (Public Resources Code section 21000 *et. seq.*).

9.5. No Litigation. Except for a validation action related to this transaction that the District may file, there is no pending or, to the knowledge of District, threatened action or proceeding before any court or federal, state, municipal, or other government authority or administrative agency which will materially adversely affect the ability of District to perform its obligations under this Facilities Lease.

9.6. Condemnation Proceedings.

9.6.1. District covenants and agrees, but only to the extent that it may lawfully do so, that so long as this Facilities Lease remains in effect, the District will not seek to exercise the power of eminent domain with respect to the Project so as to cause a full or partial termination of this Facilities Lease.

9.6.2. If for any reason the foregoing covenant is determined to be unenforceable or in some way invalid, or if District should fail or refuse to abide by such covenant, then, to the extent it may lawfully do so, District agrees that the financial interest of Developer shall be as indicated in Section 6.1 of this Facilities Lease.

10. Representations of the Developer. The Developer represents, covenants and warrants to the District as follows:

10.1. Due Organization and Existence. The Developer is a California corporation licensed to provide such services in the state of California, duly organized and existing under the laws of the State of California, has the power to enter into this Facilities Lease and the Site Lease; is possessed of full power to lease, lease back, and hold real and personal property and has duly authorized the execution and delivery of all of the aforesaid agreements.

10.2. Authorization. Developer has the full power and authority to enter into, to execute and to deliver this Facilities Lease, and to perform all of its duties and obligations hereunder, and has duly authorized the execution of this Facilities Lease.

10.3. No Violations. Neither the execution and delivery of this Facilities Lease and the Site Lease, nor the fulfillment of or compliance with the terms and conditions hereof or thereof, nor the consummation of the transactions contemplated hereby or thereby, conflicts with or results in a breach of the terms, conditions or provisions of any restriction or any agreement or instrument to which Developer is now a party or by which Developer is bound, or constitutes a default under any of the foregoing, or results in the creation or imposition of any lien, charge or encumbrance whatsoever upon any of the property or assets of Developer, or upon the Project Site, except Permitted Encumbrances.

10.4. No Bankruptcy. Developer is not now nor has it ever been in bankruptcy or receivership.

10.5. No Litigation. There is no pending or, to the knowledge of Developer, threatened action or proceeding before any court or administrative agency which will materially adversely affect the ability of Developer to perform its obligations under this Facilities Lease.

10.6. No Encumbrances. Developer shall not pledge any District payments of any kind, related to the Site Lease, this Facilities Lease, or in any way derived from the Project Site, and shall not mortgage or encumber the Project Site, except as may be specifically permitted pursuant to the provisions of this Facilities Lease related to Developer's financing the construction of the project.

10.7. Continued Existence. Developer shall not voluntarily commence any act intended to dissolve or terminate the legal existence of Developer, at or before the latest of the following:

10.7.1. Eighteen (18) months following Project Completion,

10.7.2. After dismissal and final resolution of any and all disputes between the Parties and/or any third-party claims related, in any way, to the Project,

Developer shall give District sixty (60) days written notice prior to dissolving or terminating the legal existence of Developer.

11. Construction Of Project

11.1. Project Site Conditions and Contract Documents. Developer acknowledges that it has and will perform certain special services in preparation to construct the Project.

11.2. Construction of Project.

11.2.1. Developer agrees to cause the Project to be developed, constructed, and installed in accordance with the terms hereof and the Construction Provisions set forth in **Exhibit D**, including those things reasonably inferable in the Construction Provisions as being within the scope of the Project and necessary to produce the stated result even though no mention is made in the Construction Documents.

11.2.2. **Contract Time / Construction Schedule.** It hereby understood and agreed that assuming the District issues a Notice to Proceed on or before **June 19, 2013**, District and Developer may also approve additional changes in the Construction Schedule. District shall have beneficial occupancy on or before **December 27, 2013**, and Project Completion shall on or before **February**

10, 2013. The time period between the Notice to Proceed and Completion shall be the total Contract time ("Contract Time"). The Construction shall be performed pursuant to the construction schedule, attached hereto as **Exhibit F** ("Construction Schedule"). The Construction Schedule must be approved by the District prior to execution of this Facilities Lease.

11.2.3. **Schedule of Values.** The Developer has provided a schedule of values, approved by the District, which attached hereto as **Exhibit G** ("Schedule of Values"). The Schedule of Values must be approved by the District prior to execution of this Facilities Lease.

11.2.4. **Liquidated Damages:** Time is of the essence for all work Developer must perform to obtain Project Completion. It is hereby understood and agreed that it is and will be difficult and/or impossible to ascertain and determine the actual damage that the District will sustain in the event of and by reason of Developer's delay; therefore, Developer agrees that it shall pay to the District the sum of **Three Thousand Dollars (\$3,000.00)** per day as liquidated damages for each and every day's delay beyond the Contract Time.

11.2.4.1. It is hereby understood and agreed that the liquidated damages daily amount is not a penalty.

11.2.4.2. In the event any portion of the liquidated damages is not paid to the District, the District may deduct that amount from any money due or that may become due the Developer under this Facilities Lease. The District's right to assess liquidated damages is as indicated herein and in the **Exhibit D**.

11.2.4.3. The time during which the construction of the Project is delayed for cause as hereinafter specified may extend the Contract Time for a reasonable time as the District may grant. This provision does not exclude the recovery of damages for delay by either party under other provisions in this Facilities Lease

11.2.5. **Guaranteed Project Cost.** Developer will cause the Project to be constructed within the Guaranteed Project Cost as set forth and defined in the Guaranteed Project Cost Provisions indicated in **Exhibit C** and Developer will not seek additional compensation from District in excess of that amount.

11.2.6. **Modifications.** If the DSA requires changes to the Contract Documents submitted by District to Developer, and those changes change the construction costs and/or construction time for the Project, then those changed costs will be handled as a Modification pursuant to the provisions of **Exhibit D**.

11.2.7. Developer shall cooperate with the District's efforts to obtain State funding for the Project by complying with any State requirements as reasonably requested.

12. Maintenance. Following delivery of possession of the Project by Developer to District, the repair, improvement, replacement and maintenance of the Project and the Project Site shall be at the sole cost and expense and the sole responsibility of the District, subject only to all warranties against defects in materials and workmanship of Developer as provided in **Exhibit D**. The District shall pay for or otherwise arrange for the payment of the cost of the repair and replacement of the Project resulting from ordinary wear and tear. The District waives the benefits of subsections 1 and 2 of Section 1932 of the California Civil Code, but such waiver shall not limit any of the rights of the District under the terms of this Facilities Lease.

13. Utilities. Following delivery of possession of the Project by Developer to District, the cost and expenses for all utility services, including, but not limited to, electricity, natural gas, telephone, water, sewer, trash removal, cable

television, janitorial service, security, heating, water, internet service and all other utilities of any type shall be paid by District.

14. Taxes and Other Impositions. All ad valorem real property taxes, special taxes, possessory interest taxes, bonds and special lien assessments or other impositions of any kind with respect to the Project, the Project Site and the improvements thereon, charged to or imposed upon either Developer or the District or their respective interests or estates in the Project, shall at all times be paid by District. In the event any possessory interest tax is levied on Developer, its successors and assigns, by virtue of this Facilities Lease or the Site Lease, District shall pay such possessory interest tax directly, if possible, or shall reimburse Developer, its successors and assigns for the full amount thereof within thirty (30) days after presentation of proof of payment by Developer.

15. Insurance

15.1. Developer's Insurance. The Developer shall comply with the insurance requirements as indicated herein.

15.1.1. **Commercial General Liability and Automobile Liability Insurance.** Developer shall procure and maintain, during the life of the Project, Commercial General Liability Insurance and Automobile Liability Insurance that shall protect Developer, District, and the State, from all claims for bodily injury, property damage, personal injury, death, advertising injury, and medical payments arising from operations under the Project. Developer shall ensure that Products Liability and Completed Operations coverage, Fire Damage Liability, and Any auto including owned and non-owned, are included within the above policies and at the required limits, or Developer shall procure and maintain these coverages separately.

15.1.2. **Umbrella Liability Insurance**

15.1.2.1. Developer may procure and maintain, during the life of the Project, an Umbrella Liability Insurance Policy to meet the policy limit requirements of the required policies if Developer's underlying policy limits are less than required.

15.1.2.2. There shall be no gap between the per occurrence amount of any underlying policy and the start of the coverage under the Umbrella Liability Insurance Policy. Any Umbrella Liability Insurance Policy shall protect Developer, District, and the State, in amounts and including the provisions and requirements for Commercial General Liability and Automobile Liability and Employers' Liability Insurance.

15.1.3. **Subcontractor:** Developer shall require its Subcontractor(s), if any, to procure and maintain Commercial General Liability Insurance, Automobile Liability Insurance, and Umbrella Liability Insurance with minimum limits as appropriate and required by the Developer.

15.1.4. **Workers' Compensation and Employers' Liability Insurance**

15.1.4.1. In accordance with provisions of section 3700 of the California Labor Code, the Developer and every Subcontractor shall be required to secure the payment of compensation to its employees.

15.1.4.2. Developer shall procure and maintain, during the life of the Project, Workers' Compensation Insurance and Employers' Liability Insurance for all of its employees engaged in work under the Project, on/or at the Site of the Project. This coverage shall cover, at a minimum, medical and surgical treatment, disability benefits, rehabilitation therapy, and survivors' death benefits. Developer shall require its Subcontractor(s), if any, to procure and maintain

Workers' Compensation Insurance and Employers' Liability Insurance for all employees of Subcontractor(s). Any class of employee or employees not covered by a Subcontractor's insurance shall be covered by Developer's insurance. If any class of employee or employees engaged in Work under the Project, on or at the Site of the Project, is not protected under the Workers' Compensation Insurance, Developer shall provide, or shall cause a Subcontractor to provide, adequate insurance coverage for the protection of any employee(s) not otherwise protected before any of those employee(s) commence work.

15.1.5. **Developer's Risk Insurance: Developer's Risk "All Risk" Insurance.** Developer shall procure and maintain, during the life of the Project, Developer's Builders Risk (Course of Construction), or similar first party property coverage acceptable to the District, issued on a replacement cost value basis. The cost shall be consistent with the total replacement cost of all insurable Work of the Project included within the Contract Documents. Coverage is to insure against all risks of accidental physical loss and shall include without limitation the perils of vandalism and/or malicious mischief (both without any limitation regarding vacancy or occupancy), sprinkler leakage, civil authority, sonic disturbance, earthquake, flood, collapse, wind, fire, lightning, and smoke. Coverage shall include debris removal, demolition, increased costs due to enforcement of all applicable ordinances and/or laws in the repair and replacement of damaged and undamaged portions of the property, and reasonable costs for the Architect's and engineering services and expenses required as a result of any insured loss upon the Work and Project, including completed Work and Work in progress, to the full insurable value thereof. The deductible for this insurance shall be paid by Developer.

15.1.6. **Professional Liability.** This insurance shall cover the Developer and his/her sub-consultant(s) for professional liability in at least the amounts set forth herein below. Additionally, the policy must contain terms or endorsements extending coverage that requires the insurer to defend and indemnify for acts which happen before the effective date of the policy provided the claim is first made during the policy period, coverage to continue through Project Completion plus "tail" coverage for two (2) years thereafter.

15.1.7. **Proof of Insurance and Other Requirements: Endorsements and Certificates**

15.1.7.1. Developer shall not commence Work nor shall it allow any Subcontractor to commence Work under the Project, until Developer and its Subcontractor(s) have procured all required insurance and Developer has delivered in duplicate to the District all insurance certificates indicating the required coverages have been obtained, and the District has approved these documents. If the District requests copies of Developer's insurance policies and/or endorsements from Developer, Developer shall provide them within fourteen (14) days.

15.1.7.2. Endorsements, certificates, and insurance policies shall include the following:

15.1.7.2.1. A clause stating:

"This policy shall not be amended, canceled or modified and the coverage amounts shall not be reduced until notice has been mailed to the District and Construction Manager stating date of amendment, modification, cancellation or reduction. Date of amendment, modification, cancellation or reduction may not be less than thirty (30) days after date of mailing notice."

15.1.7.2.2. Language stating in particular those insured, extent of insurance, location and operation to which insurance applies, expiration date, to whom cancellation and reduction notice will be sent, and length of notice period.

- 15.1.7.3. All endorsements, certificates and insurance policies shall state that District, its Board members, employees and agents, and the State of California, are named additional insureds under all policies except Workers' Compensation Insurance, Professional Liability Insurance, and Employers' Liability Insurance.
- 15.1.7.4. Developer's and Subcontractors' insurance policy(s) shall be primary and non-contributory to any insurance or self-insurance maintained by District, its trustees, employees and/or agents, the State of California, Construction Manager(s), Project Manager(s), Inspector(s), and/or Architect(s).
- 15.1.7.5. All endorsements, except for Professional Liability, shall waive any right to subrogation against any of the named additional insureds, except Architect.
- 15.1.7.6. All policies shall be written on an occurrence form, except for Professional Liability which shall be on a claims-made form.
- 15.1.7.7. All of Developer's insurance shall be with **ADMITTED** insurance companies with an A.M. Best rating of no less than **A: VII**. Developer shall provide documentation to the District demonstrating this rating.
- 15.1.8. **Insurance Policy Limits.** The limits of insurance shall not be less than the following amounts or as per the District's standard attached:

Commercial General Liability	Combined Single Limit	\$2,000,000
	General Aggregate	\$2,000,000
	Product Liability and Completed Operations	\$1,000,000
Automobile Liability – Any Auto	Combined Single Limit	\$2,000,000
Workers Compensation		Statutory limits pursuant to State law
Employers' Liability		\$1,000,000
Developers Risk (Course of Construction)		Issued for the value and scope of Work indicated herein.
Excess Liability		\$5,000,000
Professional Liability, If required by the District and either: - the premium is approved by the District, or - by each subconsultant and/or designer of documents produced by Developer.		\$1,000,000 per occurrence and annual aggregate

15.2. District's Insurance.

- 15.2.1. **Rental Interruption Insurance.** District shall at all times from and after District's acceptance of the Project, carry and maintain in force for the benefit of District and Developer, as their interests may appear, rental interruption insurance to cover loss, total or partial, of the use of the Project due to damage or destruction, in an amount at least equal to the maximum estimated Lease Payments payable under this Facilities Lease during the current or any future twelve (12) month period. This insurance may be maintained as part of or in conjunction with any other insurance coverage carried by the District, and such insurance may be maintained in

whole or in part in the form of participation by the District in a joint powers agency or other program providing pooled insurance. This insurance may not be maintained in the form of self-insurance. The proceeds of this insurance shall be paid to the Developer in lieu of the Lease Payments that would otherwise be due and owing during this period.

- 15.2.2. **Property Insurance.** District shall at all times from and after District's acceptance of the Project, carry and maintain in force a policy of property insurance for 100% of the insurable replacement value with no coinsurance penalty, on the Project Site and the Project, together with all improvements thereon, under a standard "all risk" contract insuring against loss or damage. Developer shall be named as additional insureds or co-insureds thereon by way of endorsement. District shall not be relieved from the obligation of supplying any additional funds for replacement of the Project and the improvements thereon in the event of destruction or damage where insurance does not cover replacement costs. District shall have the right to procure the required insurance through a joint powers agency or to self-insure against such losses or portion thereof as is deemed prudent by District.
- 15.2.3. **Commercial General Liability Insurance.** District shall at all times from and after District's acceptance of the Project, carry and maintain in force a policy of commercial general liability insurance policy of \$1,000,000. Developer shall be named as an additional insured or co-insured thereon by way of endorsement. District shall have the right to procure the required insurance through a joint powers agency or to self-insure against such losses or portion thereof as is deemed prudent by District.

16. Indemnification.

16.1. Developer's Indemnity Obligation. The Developer shall indemnify, defend with legal counsel reasonably acceptable to the District, keep and hold harmless the District, and their respective board members, officers, representatives, and employees, in both individual and official capacities ("Indemnitees"), against all suits, claims, damages, losses, and expenses, caused by, arising out of, resulting from, or incidental to, the performance of the Work under this Contract by the Developer or its Subcontractors to the full extent allowed by the laws of the State of California, and not to any extent that would render these provisions void or unenforceable, including, without limitation, any such suit, claim, damage, loss, or expense attributable to, without limitation, bodily injury, sickness, disease, death, alleged patent violation or copyright infringement, or to injury to or destruction of tangible property (including damage to the Work itself not covered by Developer's and/or District's insurance policy(s) and including the loss of use resulting therefrom), except to the extent caused by the negligence or willful misconduct of the Indemnitees. This agreement and obligation of the Developer shall not be construed to negate, abridge, or otherwise reduce any right or obligation of indemnity that would otherwise exist as to any party or person described herein. This indemnification, defense, and hold harmless obligation includes any failure or alleged failure by Developer to comply with any provision of law or the Contract Documents, including, without limitation, any stop notice actions, stop payment notice actions, or liens by the California Department of Labor Standards Enforcement.

- 16.1.1. The Developer shall give prompt notice to the District in the event of any injury (including death), loss, or damage included herein. Without limitation of the provisions herein, if the Developer's agreement to indemnify, defend, and hold harmless the Indemnitees as provided herein against liability for damage arising out of bodily injury to persons or damage to property caused by or resulting from the negligence of any of the Indemnitees shall to any extent be or be determined to be void or unenforceable, it is the intention of the Parties that these circumstances shall not otherwise affect the validity or enforceability of the Developer's agreement to indemnify, defend, and hold harmless the rest of the Indemnitees, as provided herein, and in the case of any such suits, claims, damages, losses, or expenses caused in part by the default, negligence, or act

or omission of the Developer, any Subcontractor, anyone directly or indirectly employed by any of them or anyone for whose acts any of them may be liable, and in part by any of the Indemnitees, the Developer shall be and remain fully liable on its agreements and obligations herein to the full extent permitted by law.

- 16.1.2. In any and all claims against any of the Indemnitees by any employee of the Developer, any Subcontractor, anyone directly or indirectly employed by any of them or anyone for whose acts any of them may be liable, the Developer's indemnification obligation herein shall not be limited in any way by any limitation on the amount or type of damages, compensation, or benefits payable by or for the Developer or any Subcontractor under workers' compensation acts, disability benefit acts, or other employee benefit acts.

16.2. District's Indemnity Obligation. District shall indemnify, defend and hold harmless Developer and Developer's officers, directors, shareholders, partners, members, agents and employees from and against any claims, damages, costs, expenses, judgments or liabilities connected with this Facilities Lease, including, without limitation claims, damages, expenses, or liabilities for loss or damage to any property or for death or injury to any person or persons, only to the extent that those claims, damages, expenses, judgments or liabilities arise from the negligence or willful acts or omissions of District, its officers, agents or employees at the Project.

17. Eminent Domain.

17.1. Total Taking After Project Delivery. If, following delivery of possession of the Project by Developer to District, all of the Project and the Project Site is taken permanently under the power of eminent domain, the Term shall cease as of the day possession shall be so taken.

- 17.1.1. The financial interest of Developer shall be limited to the amount of principal payments pursuant to the Guaranteed Project Cost Provisions indicated in **Exhibit C** that are then due or past due together with all remaining and succeeding principal payments pursuant to the Guaranteed Project Cost Provisions indicated in **Exhibit C** for the remainder of the original Term.

- 17.1.2. The balance of the award, if any, shall be paid to the District.

17.2. Total Taking Prior to Project Delivery. If all of the Project and the Project Site is taken permanently under the power of eminent domain and the Developer is still performing the work of the Project and has not yet delivered possession of the Project to District, the Term shall cease as of the day possession shall be so taken. The financial interest of Developer shall be the amount Developer has expended to date for work performed on the Project, subject to documentation reasonably satisfactory to the District.

17.3. Partial Taking. If, following delivery of possession of the Project by Developer to District, less than all of the Project and the Project Site is taken permanently, or if all of the Project and the Project Site or any part thereof is taken temporarily, under the power of eminent domain:

- 17.3.1. This Facilities Lease shall continue in full force and effect and shall not be terminated by virtue of that partial taking and the Parties waive the benefit of any law to the contrary, and

- 17.3.2. There shall be a partial abatement of any principal payments pursuant to the Guaranteed Project Cost Provisions indicated in **Exhibit C** as a result of the application of the net proceeds of any eminent domain award to the prepayment of those payments hereunder. The Parties agree to negotiate, in good faith, for an equitable split of the net proceeds of any eminent domain award and a corresponding reduction in the payments required pursuant to the Guaranteed Project Cost Provisions indicated in **Exhibit C**, and

18. Damage and Destruction. If, following delivery of possession of the Project by Developer to District, the Project is totally or partially destroyed due to fire, acts of vandalism, flood, storm, earthquake, Acts of God, or other casualty beyond the control of either party hereto, the Term shall end and District shall still no longer be required to make any payments required pursuant to the Guaranteed Project Cost Provisions indicated in **Exhibit C** that are then due or past due or any remaining and succeeding principal payments pursuant to the Guaranteed Project Cost Provisions indicated in **Exhibit C** for the remainder of the original Term. The Developer shall still be due any funds, payments, or disbursements from the District's rental interruption insurance to pay for the amounts that would otherwise have been due and owing from the District under **Exhibit C**.

19. Abatement.

19.1. If, after the Parties have executed the Memorandum of Commencement Date attached hereto as **Exhibit E**, the Project becomes destroyed or damaged beyond repair, the District may determine its use of the Project abated. Thereafter, the District shall have no obligation to make, nor shall the Developer have the right to demand, any future Lease Payments as indicated in the Guaranteed Project Cost Provisions indicated in **Exhibit C** to this Facilities Lease. The Term shall cease at that time.

19.2. The Parties hereby agree that the net proceeds of the District's rental interruption insurance that the District must maintain during the Term, as required herein, shall constitute a special fund for the payment of the Lease Payments indicated in the Guaranteed Project Cost Provisions indicated in **Exhibit C**.

19.3. The District shall as soon as practicable after such event, apply the net proceeds of its insurance policy intended to cover that loss ("Net Proceeds"), either to:

19.3.1. Repair the Project to full use;

19.3.2. Replace the Project, at the District's sole cost and expense, with property of equal or greater value to the Project immediately prior to the time of the destruction or damage, with that replacement, once completed, shall be substituted in this Facilities Lease by appropriate endorsement; or

19.3.3. Exercise the District's purchase option as indicated in the Guaranteed Project Cost Provisions indicated in **Exhibit C** to this Facilities Lease.

19.4. The District shall notify the Developer of which course of action it desires to take within thirty (30) days after the occurrence of the destruction or damage. The Net Proceeds of all insurance payable with respect to the Project shall be available to the District and shall be used to discharge the District's obligations under this Section.

20. Access

20.1. By Developer. Developer shall have the right at all reasonable times to enter upon the Project Site to construct the Project pursuant to this Facilities Lease. Following the acceptance of the Project by District, Developer may enter the Project at reasonable times with advance notice and arrangement with District for purposes of making any repairs required to be made by Developer.

20.2. By District. The District shall have the right to enter upon the Project Site at all times. District shall comply with all safety precautions and procedures required by Developer.

21. Assignment, Subleasing

21.1. Assignment and Subleasing by the District. Any assignment or sublease by District shall be subject to all of the following conditions:

- 21.1.1. This Facilities Lease and the obligation of the District to make the payments required pursuant to the Guaranteed Project Cost Provisions indicated in **Exhibit C** shall remain obligations of the District; and
- 21.1.2. The District shall, within thirty (30) days after the delivery thereof, furnish or cause to be furnished to Developer a true and complete copy of any assignment or sublease; and

21.2. Assignment by Developer. Developer may assign its right, title and interest in this Facilities Lease, in whole or in part to one or more assignees, only after the written consent of District, which District will not unreasonably withhold. No assignment shall be effective against the District unless and until the District has consented in writing. Notwithstanding anything to contrary contained in this Facilities Lease, no consent from the District shall be required in connection with any assignment by Developer to a lender for purposes of financing the Project as long as there are not additional costs to the District.

22. Events Of Default of District

22.1. Events of Default by District Defined. The following shall be “Events of Default” of the District under this Facilities Lease. The terms “Event of Default” and “Default” shall mean, whenever they are used as to the District in the Site Lease or this Facilities Lease, shall only be one or more of the following events:

- 22.1.1. Failure by the District to pay payments required pursuant to the Guaranteed Project Cost Provisions indicated in **Exhibit C**, and the continuation of such failure for a period of forty-five (45) days.
- 22.1.2. Failure by the District to perform any material covenant, condition or agreement in this Facilities Lease and that failure continues for a period of forty-five (45) days after Developer provides District with written notice specifying that failure and requesting that the failure be remedied; provided, however, if the failure stated in the notice cannot be corrected within the applicable period, Developer shall not unreasonably withhold its consent to an extension of such time if corrective action is instituted by the District within the applicable period and diligently pursued until the default is corrected.

22.2. Remedies on District’s Default. If there has been an Event of Default on the District’s part, the Developer may exercise any and all remedies available pursuant to law or granted pursuant to this Facilities Lease; provided, however, there shall be no right under any circumstances to accelerate any of the payments required pursuant to the Guaranteed Project Cost Provisions indicated in **Exhibit C** or otherwise declare those payments not then past due to be immediately due and payable.

- 22.2.1. Developer may rescind its leaseback of the Project Site to the District under this Facilities Lease and re-rent the Project Site to another lessee for the remaining Term for no less than the fair market value for leasing the Project Site, which shall be:
 - 22.2.1.1. An amount determined by a mutually-agreed upon appraiser, or
 - 22.2.1.2. If an appraiser cannot be agreed to, an amount equal to the mean between a District appraisal and a Developer appraisal for the Project Site, both prepared by an MAI-certified appraiser.

22.2.2. District's obligation to make the payments required pursuant to the Guaranteed Project Cost Provisions indicated in **Exhibit C** shall be:

22.2.2.1. Increased by the amount of costs, expenses, and damages incurred by the Developer in re-renting the Project Site, and

22.2.2.2. Decreased by the amount of rent Developer receives in reletting the Project Site.

22.2.3. The District agrees that the terms of this Facilities Lease constitute full and sufficient notice of the right of Developer to re-rent the Project Site in the Event of Default without effecting a surrender of this Facilities Lease, and further agrees that no acts of Developer in performing a re-renting as permitted herein shall constitute a surrender or termination of this Facilities Lease, but that, on the contrary, in the event of an Event of Default by the District the right to re-rent the Project Site shall vest in Developer as indicated herein.

22.3. District's Continuing Obligation. Unless there has been damage, destruction, a Taking as described above, or the Developer is in Default as indicated herein, the District shall continue to remain liable for the payments required pursuant to the Guaranteed Project Cost Provisions indicated in **Exhibit C** and those amounts shall be payable to Developer at the time and in the manner as therein provided.

22.4. No Remedy Exclusive. No remedy herein conferred upon or reserved to Developer is intended to be exclusive and every such remedy shall be cumulative and shall be in addition to every other remedy given under this Facilities Lease or now or hereafter existing at law or in equity. No delay or omission to exercise any right or power accruing upon any Default shall impair any such right or power or shall be construed to be a waiver thereof, but any such right and power may be exercised from time to time and as often as may be deemed expedient. In order to entitle Developer to exercise any remedy reserved to it in this Article 9, it shall not be necessary to give any notice, other than such notice as may be required in this Article or by law.

23. Events Of Default of Developer

23.1. Events of Default by Developer Defined. The following shall be "Events of Default" of the Developer under this Facilities Lease. The terms "Event of Default" and "Default" shall mean, whenever they are used as to the Developer in the Site Lease or this Facilities Lease, shall only be one or more of the following events:

23.1.1.1. Developer unreasonably refuses or fails to prosecute the work on the Project with such reasonable diligence as will accomplish Project Completion within the Contract Time or any extension thereof;

23.1.1.2. Prior to Project Completion, Developer is adjudged a bankrupt, or files for bankruptcy, or if it should make a general assignment for the benefit of its creditors, or if a receiver should be appointed on account of its insolvency;

23.1.1.3. Developer persistently disregards applicable law as indicated in **Exhibit D**, or otherwise be in violation of **Exhibit D**.

23.1.2. Failure by the Developer to perform any material covenant, condition or agreement in this Facilities Lease and that failure continues for a period of forty-five (45) days after District provides Developer with written notice specifying that failure and requesting that the failure be remedied; provided, however, if the failure stated in the notice cannot be corrected within the applicable period, District shall not unreasonably withhold its consent to an extension of such time if corrective action is instituted by the Developer within the applicable period and diligently pursued until the default is corrected.

23.2. Remedies on Developer’s Default. If there has been an Event of Default on the Developer’s part, the District may, without prejudice to any other right or remedy, terminate the Site Lease and Facilities Lease.

23.2.1. If District terminates the Site Lease and the Facilities Lease pursuant to this section, the Project Site and any improvements built upon the Project Site shall vest in District upon termination of the Site Lease and Facilities Lease, and District shall thereafter be required to pay only the principal amounts then due and owing pursuant to the Guaranteed Project Cost Provisions indicated in **Exhibit C**, less any damages incurred by District due to Developer’s Default.

23.2.2. The District shall retain all rights it possesses as indicated in **Exhibit D** including, without limitation,

23.2.2.1. The right to assess liquidated damages due as permitted herein;

23.2.2.2. All rights the District holds to demand performance pursuant to the Developer’s required performance bond;

24. Notices. All notices, certificates or other communications hereunder shall be sufficiently given and shall be deemed to have been received as indicated below and to the persons indicated below:

24.1. If notice is given by personal delivery thereof, it shall be considered delivered on the day of delivery.

24.2. If notice is given by overnight delivery service, it shall be considered delivered on (1) day after date deposited, as indicated by the delivery service.

24.3. If notice is given by depositing same in United States mail, enclosed in a sealed envelope, it shall be considered delivered three (3) days after date deposited, as indicated by the postmarked date.

24.4. If notice is given by registered or certified mail with postage prepaid, return receipt requested, it shall be considered delivered on the day the notice is signed for

If to District:

Mount Diablo Unified School District
 1936 Carlotta Drive
 Concord, CA 9519-1397
 Attention: Superintendent

Telephone: (925)682-8000
 Facsimile: (925)680-2505

With a copy to:

Orbach Huff & Suarez
 1 Kaiser Plaza, Ste. 1458
 Oakland, CA 94612
 Attention: Philip J. Henderson
 Telephone: (510) 999-7908
 Facsimile: (510) 999-7918

If to Developer:

_____, Inc.

 _____, CA 9_____
 Attention: _____

Telephone: () ____-_____
 Facsimile: () ____-_____

 _____, CA 9_____
 Attention: _____
 Telephone: () ____-_____
 Facsimile: () ____-_____

The Developer and the District, by notice given hereunder, may designate different addresses to which subsequent notices, certificates or other communications will be sent.

25. Binding Effect. This Facilities Lease shall inure to the benefit of and shall be binding upon Developer and the District and their respective successors, transferees and assigns.

26. No Additional Waiver Implied by One Waiver. In the event any agreement contained in this Facilities Lease should be breached by either party and thereafter waived by the other party, such waiver shall be limited to the particular breach so waived and shall not be deemed to waive any other breach hereunder.

27. Severability. In the event any provision of this Facilities Lease shall be held invalid or unenforceable by any court of competent jurisdiction, such holding shall not invalidate or render unenforceable any other provision hereof, unless elimination of such invalid provision materially alters the rights and obligations embodied in this Facilities Lease or the Site Lease.

28. Amendments, Changes and Modifications. Except as to the termination rights of both Parties as indicated herein, this Facilities Lease may not be amended, changed, modified, altered or terminated without the written agreement of both Parties hereto.

29. Net-Net-Net Lease. This Facilities Lease shall be deemed and construed to be a “net-net-net lease” and the District hereby agrees that all payments it makes pursuant to the Guaranteed Project Cost Provisions indicated in **Exhibit C** shall be an absolute net return to Developer, free and clear of any expenses, charges or set-offs.

30. Execution in Counterparts. This Facilities Lease may be executed in several counterparts, each of which shall be an original and all of which shall constitute but one and the same instrument.

31. Developer and District Representatives. Whenever under the provisions of this Facilities Lease the approval of Developer or the District is required, or Developer or the District is required to take some action at the request of the other, such approval or such request shall be given for Developer by Developer’s Representative and for the District by the District’s Representative, and any party hereto shall be authorized to rely upon any such approval or request.

32. Applicable Law. This Facilities Lease shall be governed by and construed in accordance with the laws of the State of California, and venued in the County within which the School Site is located.

33. Attorney's Fees. If either party brings an action or proceeding involving the Property or to enforce the terms of this Facilities Lease or to declare rights hereunder, each party shall bear the cost of its own attorneys’ fees.

34. Captions. The captions or headings in this Facilities Lease are for convenience only and in no way define, limit or describe the scope or intent of any provisions or Sections of this Facilities Lease.

35. Prior Agreements. This Facilities Lease and the corresponding Site Lease collectively contain all of the agreements of the Parties hereto with respect to any matter covered or mentioned in this Facilities Lease and no prior agreements or understanding pertaining to any such matter shall be effective for any purpose.

36. Further Assurances. Parties shall promptly execute and deliver all documents and instruments reasonably requested to give effect to the provisions of this Facilities Lease.

37. Recitals Incorporated. The Recitals set forth at the beginning of this Facilities Lease are hereby incorporated into its terms and provisions by this reference.

38. Time of the Essence. Time is of the essence with respect to each of the terms, covenants, and conditions of this Facilities Lease.

39. Force Majeure. A party shall be excused from the performance of any obligation imposed in this Facilities Lease and the exhibits hereto for any period and to the extent that a party is prevented from performing such obligation, in whole or in part, as a result of delays caused by the other party or third parties, a governmental agency or entity, an act of God, war, terrorism, civil disturbance, forces of nature, fire, flood, earthquake, strikes or lockouts , and such non performance will not be a default hereunder or a grounds for termination of this Facilities Lease.

40. Interpretation. None of the Parties hereto, nor their respective counsel, shall be deemed the drafters of this Facilities Lease for purposes of construing the provisions thereof. The language in all parts of this Facilities Lease shall in all cases be construed according to its fair meaning, not strictly for or against any of the Parties hereto.

IN WITNESS WHEREOF, the Parties have caused this Facilities Lease to be executed by their respective officers who are duly authorized, as of the Effective Date.

ACCEPTED AND AGREED on the date indicated below:

Dated: _____, 20____

Dated: _____, 20____

Mount Diablo Unified School District

_____, **Inc.**

By: _____

By: _____

Print Name: _____

Print Name: _____

Print Title: Superintendent

Print Title: _____

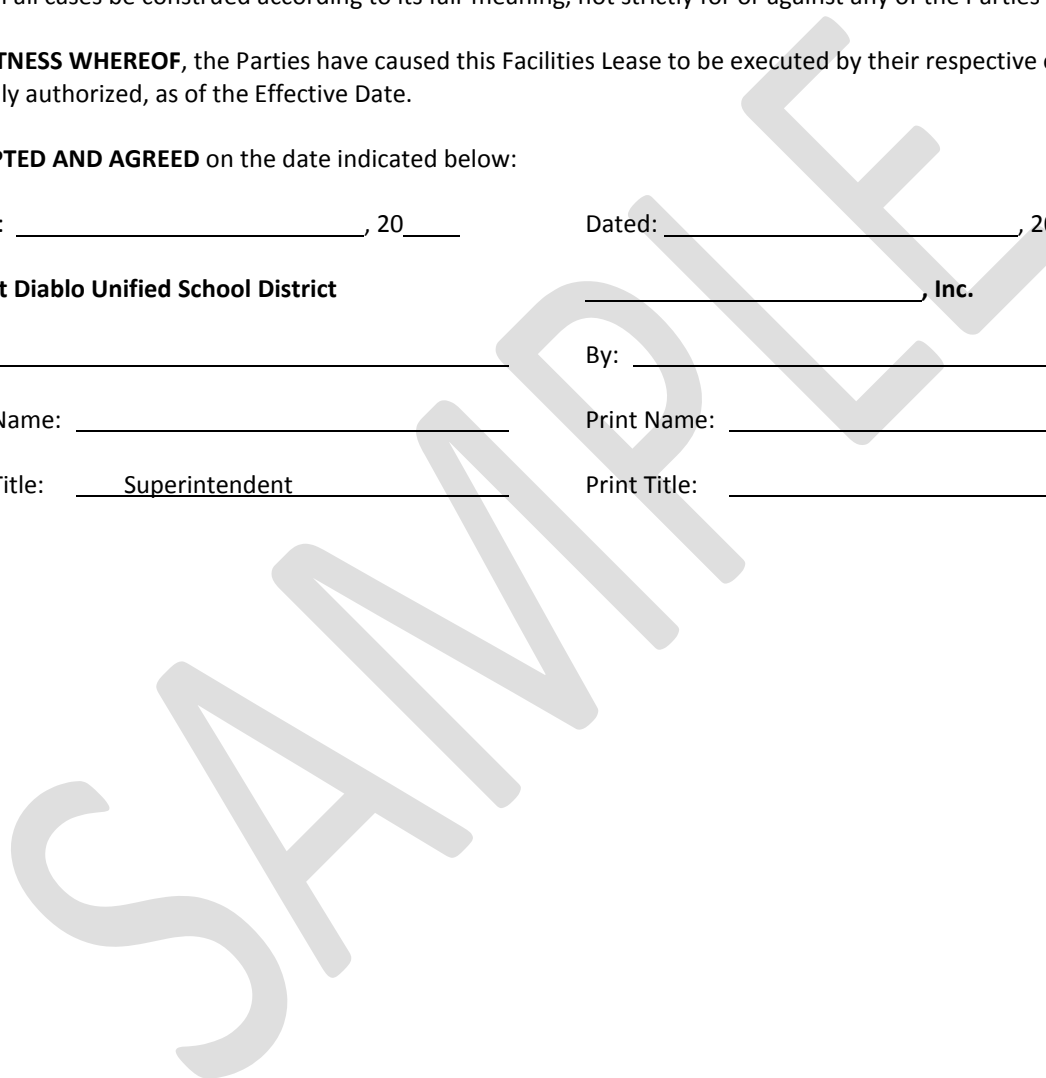

**EXHIBIT "C"
TO
FACILITIES LEASE**

**GUARANTEED PROJECT COST AND
OTHER PROJECT COST, FUNDING, AND PAYMENT PROVISIONS**

1. Site Lease Payments. As indicated in the Site Lease, Developer shall pay One Dollar (\$1.00) to the District as consideration for the Site Lease.

2. Guaranteed Project Cost. Pursuant to the Facilities Lease, Developer will cause the Project to be constructed for _____ Dollars (\$ _____), ("Guaranteed Project Cost"). Except as indicated herein for modifications to the Project approved by the District, Developer will not seek additional compensation from District in excess of Guaranteed Project Cost. District shall pay the Guaranteed Project Cost to Developer in the form of Tenant Improvement Payments and Lease Payments as indicated herein. The Guaranteed Project Cost includes the following components and as further detailed herein:

2.1. Cost to Perform Work.

2.1.1. Subcontract Costs. Payments made by the Developer to Subcontractors, which payments shall be made in accordance with the requirements of the Contract Documents.

2.1.2. Developer-Performed Work. Costs incurred by the Developer for self-performed work.

2.2. General Conditions. The amount to be paid be for all costs for labor, equipment and materials for the items identified therein which are necessary for the proper management of the Project, and shall include all costs paid or incurred by the Developer for insurance (except for general liability insurance), permits, taxes, and all contributions, assessments and benefits, holidays, vacations, retirement benefits, and incentives, whether required by law or collective bargaining agreements or otherwise paid or provided by Developer to its employees. The District reserves the right to request changes to the personnel, equipment, or facilities provided as General Conditions as may be necessary or appropriate for the proper management of the Project, in which case, the District shall be entitled to a reduction in the cost of General Conditions.

2.3. Fees. All fees, assessments and charges that are required to be paid to other agencies or entities to permit, authorize or entitle construction, reconstruction or completion of the Project.

2.4. Allowances. The following allowances are within the Guaranteed Project Cost. Developer shall be permitted to charge only its direct costs to perform the work, as indicated through documentation approved to the District. Developer shall not include in its charge(s) under a particular allowance the coordination, supervision, bond costs, overhead and profit, installation and all indirect costs associated with performing the work of each allowance.

2.4.1. N/A

Any unused allowance or unused portion thereof shall be deducted from the Cost of the Work. The amount to deduct shall be calculated using the steps in the "Changes in the Work" provisions of **Exhibit "D"** to the Facilities Lease including the Deductive Change Order provisions therein.

2.5. Contingency. Contingency of _____ (\$ _____) for potential additional construction costs that occur over the course of construction that Developer could have discovered during its preparation of the GPC or for scope gap, but which Developer did not include and which Developer can document to the District's

satisfaction were missed by Developer during its preparation of the GPC. The Contingency is not intended for such things as "Changes" as further described herein. The Contingency shall not be used without the agreement of the District. The unused portion of the Contingency shall be retained by the District at the end of the Project. The Developer cannot request any additional fee for any missed costs in excess of this Contingency.

2.5.1. Conflicts, ambiguities or omissions in the scope(s) of Work that Developer could have discovered during its preparation of the GPC, but which Developer did not include and which Developer can document to the District's satisfaction were missed by Developer during its preparation of the GPC. The Developer cannot request any additional fee for its fee for this use of the Contingency; or

2.5.2. Unforeseen conditions, cost overruns or costs of accelerating portions of the Work.

2.6. Bonds and Insurance.

2.7. Overhead and Profit.

3. Payment of Guaranteed Project Cost. District shall pay the Guaranteed Project Cost to Developer in the form of Tenant Improvement Payments and Lease Payments as indicated herein.

3.1. Tenant Improvement Payments. Prior to the District's taking delivery or occupancy of the Project, the District shall pay to Developer _____ Dollars (\$) ("Tenant Improvement Payment(s)"), based on the amount of Work performed according to the Developer's Schedule of Values (**Exhibit "G"** to the Facilities Lease) and pursuant to the provisions in **Exhibit "D"** to the Facilities Lease.

3.2. Lease Payments. After the Parties execute the Memorandum of Commencement Date, attached to the Facilities Lease as **Exhibit "E,"** the District shall pay to Developer _____ Dollars (\$) ("Lease Payment(s)"), as indicated below.

3.2.1. The Lease Payments shall be consideration for the District's rental, use, and occupancy of the Project and the Project Site and shall be made in equal monthly installments for the duration of the Term.

3.2.2. The District represents that the total annual Lease Payment obligation does not surpass the District's annual budget and will not require the District to increase or impose additional taxes or obligations on the public that did not exist prior to the execution of the Facilities Lease.

3.2.3. **Fair Rental Value.** District and Developer have agreed and determined that the total Lease Payments constitute adequate consideration for the Facilities Lease and are reasonably equivalent to the fair rental value of the Project. In making such determination, consideration has been given to the obligations of the Parties under the Facilities Lease and Site Lease, the uses and purposes which may be served by the Project and the benefits therefrom which will accrue to the District and the general public.

3.2.4. **Each Payment Constitutes a Current Expense of the District.**

3.2.4.1. The District and Developer understand and intend that the obligation of the District to pay Lease Payments and other payments hereunder constitutes a current expense of the District and shall not in any way be construed to be a debt of the District in contravention of any applicable constitutional or statutory limitation or requirement concerning the creation of indebtedness by the District, nor shall anything contained herein constitute a pledge of the general tax revenues, funds or moneys of the District.

3.2.4.2. Lease Payments due hereunder shall be payable only from current funds which are budgeted and appropriated or otherwise made legally available for this purpose. This Facilities Lease shall not create an immediate indebtedness for any aggregate payments that may become due hereunder.

3.2.4.3. The District covenants to take all necessary actions to include the estimated Lease Payments in each of its final approved annual budgets.

3.2.4.4. The District further covenants to make all necessary appropriations (including any supplemental appropriations) from any source of legally available funds of the District for the actual amount of Lease Payments that come due and payable during the period covered by each such budget. Developer acknowledges that the District has not pledged the full faith and credit of the District, State of California or any state agency or state department to the payment of Lease Payments or any other payments due hereunder. The covenants on the part of District contained in this Facilities Lease constitute duties imposed by law and it shall be the duty of each and every public official of the District to take such action and do such things as are required by law in the performance of the official duty of such officials to enable the District to carry out and perform the covenants and agreements in this Facilities Lease agreed to be carried out and performed by the District.

3.2.4.5. The Developer cannot, under any circumstances, accelerate the District’s payments under the Facilities Lease.

3.2.5. The Lease Payment Amount shall be paid pursuant to the following structure and the annual interest rate shall be at or below the then current Prime Rate as published in the Wall Street Journal plus two percent (2 %):

Date of Payment	(A) Total Lease Payment	(B) Total Interest Due on Lease Payment	Total Lease Payment plus interest due by District to Developer (A + B)
35 days after NOC filed	\$ ____		
65 days after NOC filed	\$ ____		
95 days after NOC filed	\$ ____		
125 days after NOC filed	\$ ____		
155 days after NOC filed	\$ ____		
185 days after NOC filed	\$ ____		

3.2.6. **Financed Portion of Lease Payments.** The District does not at this time believe it will need the Developer to finance a portion of the Lease Payments. The District and the Developer have agreed that the District may request at a future time that the Developer agree to convert a portion of the Tenant Improvement Payments into Lease Payments and revise the Lease Payment schedule. If the District makes this request, the District and the Developer agree to negotiate in good faith regarding whether Developer can provide that financing, the amount of that financing, and the terms of that financing, which, if agreed to, shall be memorialized in a written amendment to the Facilities Lease and approved by the Parties.

3.3. In no event shall the cumulative total of the Tenant Improvement Payments and the Lease Payments ever exceed the Guaranteed Project Price as defined herein, unless modified pursuant to **Exhibit "D"** to the Facilities Lease.

4. Changes to Guaranteed Project Cost.

4.1. As indicated in the Facilities Lease, the Parties may add or remove specific scopes of work from the Project. Based on these change(s), the Parties may agree to a reduction or increase in the Guaranteed Project Cost. If a cost impact or a change is agreed to by the Parties, it shall be reflected as a reduction or increase in the Tenant Improvement Payments and paid upon the payment request from the Developer when the work is performed, or deducted from the next payment request from the Developer, as applicable.

4.2. The Parties acknowledge that the Guaranteed Project Cost is based on the Construction Documents, including the plans, and specifications, as identified in **Exhibit "D"** to the Facilities Lease.

4.3. Cost Savings. Developer shall work cooperatively with Architect, subcontractors and District, in good faith, to identify appropriate opportunities to reduce the Project costs and promote cost savings. Any identified cost savings from the Guaranteed Project Cost shall be identified by Developer, and if approved in writing by the District, that cost savings shall be deducted from the Guaranteed Project Cost. If any cost savings require revisions to the Construction Documents, Developer shall work with the District with respect to revising the Construction Documents and, if necessary, obtaining the approval of DSA with respect to those revisions. At the District's discretion, any reasonable cost incurred by District and/or the Developer for those revisions may be paid for out of the identified savings before it is deducted from the Guaranteed Project Cost. Developer shall be entitled to an extension of Contract Time equal to the delay in Project Completion caused by any cost savings adopted by District, if requested in writing before the approval of the cost savings.

5. District's Purchase Option

5.1. If the District is not then in uncured Default hereunder, the District shall have the option to purchase not less than all of the Project in its "as-is, where-is" condition and terminate this Facilities Lease and Site Lease by paying the total remaining unpaid Lease Payments as of the date the option is exercised ("Option Price").

5.2. District shall provide Developer no less than three (3) days' prior written notice that District is exercising its option to purchase the Project as set forth above on a specific date ("Option Date"). If the District exercises this option, the District shall pay directly to Developer the Option Price on or prior to the Option Date and Developer shall at that time deliver to District all reasonably necessary documents in recordable form to terminate this Facilities Lease and the Site Lease. District may record all such documents at District's cost and expense.

5.3. Under no circumstances can the first Option Date be on or before thirty-five (35) days after the Developer completes the Project and the District accepts the Project.

6. Agreement for Preliminary Services ("PSA"). The Parties acknowledge that Developer performed preliminary services related to the project under a PSA.

**EXHIBIT "D"
TO
FACILITIES LEASE**

GENERAL CONSTRUCTION PROVISIONS

TABLE OF CONTENTS

1. CONTRACT TERMS AND DEFINITIONS 1

 1.1. Definitions 1

 1.2. Laws Concerning The Contract 4

 1.3. No Oral Agreements..... 4

 1.4. No Assignment..... 4

 1.5. Notice And Service Thereof 4

 1.6. No Waiver 5

 1.7. Substitutions For Specified Items 5

 1.8. Materials and Work 5

2. [RESERVED] 6

3. ARCHITECT..... 6

4. CONSTRUCTION MANAGER 6

5. INSPECTOR, INSPECTIONS, AND TESTS..... 7

 5.1. Project Inspector 7

 5.2. Tests and Inspections 7

 5.3. Costs for After Hours and/or Off Site Inspections..... 8

6. DEVELOPER..... 8

 6.1. Status of Developer..... 8

 6.2. Developer’s Supervision..... 8

 6.3. Duty to Provide Fit Workers..... 9

 6.4. Purchase of Materials and Equipment 10

 6.5. Documents on Work 10

 6.6. Preservation of Records 11

 6.7. Integration of Work 11

 6.8. Obtaining Licenses 12

 6.9. Work to Comply With Applicable Laws and Regulations 12

 6.10. Safety/Protection of Persons and Property..... 13

 6.11. Working Evenings and Weekends 15

 6.12. Cleaning Up..... 15

7. SUBCONTRACTORS 16

8. OTHER CONTRACTS/CONTRACTORS 17

9. DRAWINGS AND SPECIFICATIONS 17

10. DEVELOPER’S SUBMITTALS AND SCHEDULES 18

 10.1. Construction Schedule 18

 10.2. Schedule of Values 19

 10.2. Monthly Progress Schedule(s) 20

 10.3. Material Safety Data Sheets (MSDS) 20

 10.10. Logistics Plan 20

11. SITE ACCESS, CONDITIONS, AND REQUIREMENTS 20

 11.1. Site Investigation 20

 11.2. Soils Investigation Report & Site Due Diligence..... 21

 11.3. Access to Work..... 23

 11.4. Layout and Field Engineering 23

 11.5. Utilities & Sanitary Facilities..... 23

11.6. Surveys 23

11.7. Regional Notification Center 23

11.8. Existing Utility Lines 24

11.9. Notification 24

11.10. Hazardous Materials 24

11.11. No Signs 27

12. TRENCHES..... 28

 12.1. Trenches Greater Than Five Feet 28

 12.2. Excavation Safety 28

 12.3. No Tort Liability of District 28

 12.4. No Excavation Without Permits 28

 12.5. Discovery of Hazardous Waste and/or Unusual Conditions 28

13. INSURANCE AND BONDS 29

 13.1 Developer’s Insurance 29

 13.2 Contract Security - Bonds 29

14. WARRANTY/GUARANTEE/INDEMNITY 29

 14.1. Warranty/Guarantee 29

 14.2. Indemnity..... 30

15. TIME 30

 15.1. Computation of Time / Adverse Weather 30

 15.2. Hours of Work 30

 15.3. Progress and Project Completion 31

 15.4. Schedule 31

 15.5. Expeditious Completion 31

16. EXTENSIONS OF TIME – LIQUIDATED DAMAGES 31

 16.1. Liquidated Damages 31

 16.2. Excusable Delay 31

 16.3. No Additional Compensation for Delays Within Developer’s Control 32

 16.4. Float or Slack in the Schedule..... 32

17. CHANGES IN THE WORK..... 33

 17.1. No Changes Without Authorization 33

 17.2. Architect Authority 33

 17.3. Change Orders 33

 17.4. Price Request 34

 17.5. Proposed Change Order 34

 17.6. Format for Proposed Change Order..... 34

 17.7. Change Order Certification..... 35

 17.8. Determination of Change Order Cost 36

 17.9. Deductive Change Orders..... 36

 17.10. Construction Change Directives / Unilateral Change Orders..... 36

 17.11. Discounts, Rebates, and Refunds 36

 17.12. Accounting Records..... 36

 17.13. Notice Required 37

 17.14. Applicability to Subcontractors 37

 17.15. Alteration to Change Order Language 37

 17.16. Failure of Developer to Execute Change Order 37

 17.17. Allowances..... 37

18. REQUESTS FOR INFORMATION 37

19. PAYMENTS..... 38

 19.1. Contract Price..... 38

 19.2. Applications for Tenant Improvement Payments 38

 19.3. District’s Approval of Application for Tenant Improvement Payment 40

20. COMPLETION OF THE WORK..... 44

20.1. Completion 44

20.2. Close-Out Procedures..... 44

20.3. Final Inspection 45

20.4. Costs of Multiple Inspections 46

20.5. Beneficial Occupancy or Use Prior to Project Completion 46

21. FINAL PAYMENT 47

 21.1. Final Payment 47

 21.2. Prerequisites for Final Tenant Improvement Payment 47

22. UNCOVERING OF WORK 48

23. NONCONFORMING WORK AND CORRECTION OF WORK 48

 23.1. Nonconforming Work..... 48

 23.2. Correction of Work..... 48

 23.3 District's Right to Perform Work 49

24. TERMINATION AND SUSPENSION AND SCOPE REDUCTION 49

 24.1. Emergency Termination of Public Contracts Act of 1949 49

 24.2. Suspension of Work 50

 24.3. Scope Reduction 50

25. DISPUTES AND CLAIMS 50

 25.1. Performance During Dispute And Claim Resolution Process..... 50

 25.2. Waiver 50

 25.3. Intention 50

 25.4. Exclusive Remedy..... 51

 25.5. Other Provisions..... 51

 25.6. Subcontractors..... 51

 25.7. Dispute And Claim Resolution Process 51

26. LABOR, WAGE & HOUR, APPRENTICE AND RELATED PROVISIONS 55

 26.1. Labor Compliance Program 55

 26.2. Wage Rates, Travel and Subsistence 55

 26.3. Hours of Work 56

 26.4. Payroll Records 57

 26.5. Apprentices..... 58

 26.6. Non-Discrimination 59

 26.7. Labor First Aid 60

27. MISCELLANEOUS..... 60

 27.1. Assignment of Antitrust Actions..... 60

 27.2. Excise Taxes 61

 27.3. Taxes..... 61

 27.4. Shipments 61

This Exhibit D constitutes the “General Construction Provisions” that govern the overall construction and Project Completion by Developer.

1. CONTRACT TERMS AND DEFINITIONS

1.1. Definitions

Wherever used in the Contract Documents, the following terms shall have the meanings indicated, which shall be applicable to both the singular and plural thereof:

1.1.1. Adverse Weather: Shall be only weather that satisfies all of the following conditions: (1) unusually severe precipitation, sleet, snow, hail, heat, or cold conditions in excess of the norm for the location and time of year it occurred, and (2) at the Project.

1.1.2. Allowance: Amount(s) included in the Guaranteed Project Cost that the Parties agree shall be used, if used at all, to pay for the construction of the specific scope of work identified with that amount of money. By agreeing to an Allowance amount, the Parties agree (1) the specific scope of Work may not be necessary; (2) the cost to perform the specific scope of Work cannot be determined on the Effective Date; (3) is a reasonable estimate of the cost to do the specific scope of Work.

1.1.3. Approval, Approved, and/or Accepted: Refer to written authorization, unless stated otherwise.

1.1.4. Architect: The individual, partnership, corporation, joint venture, or any combination thereof, named as Architect, who will have the rights and authority assigned to the Architect in the Contract Documents. The term Architect means the District's Architect on this Project or the Architect's authorized representative.

1.1.5. Beneficial Occupancy: Occupancy of the Project by the District for its intended purpose and which produces relatively little interference with the Developer in completing construction.

1.1.6. Change Order: A written order to the Developer authorizing an addition to, deletion from, or revision in the Work, and/or authorizing an adjustment in the Guaranteed Project Cost or Contract Time.

1.1.7. Construction Change Directive: A written order prepared and issued by the District, the Construction Manager, and/or the Architect and signed by the District and the Architect, directing a change in the Work.

1.1.8. Construction Manager: The individual, partnership, corporation, joint venture, or any combination thereof, or its authorized representative, named as such by the District. If no Construction Manager is used on the Project that is the subject of this Contract, then all references to Construction Manager herein shall be read to refer to District.

1.1.9. Construction Schedule: The progress schedule of construction of the Project as provided by Developer and approved by District.

1.1.10. Contract, Contract Documents: The Contract consists exclusively of the documents evidencing the agreement of the District and Developer, identified as the Contract Documents. The Contract Documents consist of the following documents:

- 1.1.10.1. Site Lease
- 1.1.10.2. Facilities Lease, with all of its Exhibits
- 1.1.10.3. These General Construction Provisions
- 1.1.10.4. Noncollusion Affidavit

- 1.1.10.5. Workers' Compensation Certification
- 1.1.10.6. Prevailing Wage Certification
- 1.1.10.7. Disabled Veterans Business Enterprise Participation Certification
- 1.1.10.8. Drug-Free Workplace Certification
- 1.1.10.9. Tobacco-Free Environment Certification
- 1.1.10.10. Lead-Based Paint Certification
- 1.1.10.11. Hazardous Materials Certification
- 1.1.10.12. Imported Materials Certification
- 1.1.10.13. Criminal Background Investigation/Fingerprinting Certification
- 1.1.10.14. Roofing Contract Financial Interest Certification
- 1.1.10.15. Storm Water Pollution Prevention Plan
- 1.1.10.16. Labor Compliance Program Information and Forms
- 1.1.10.17. Performance Bond
- 1.1.10.18. Payment Bond (Developer's Labor & Material Bond)
- 1.1.10.19. All Division 1 Documents, which shall only supplement these General Construction Provisions, but shall not control if their provisions contradict these Construction Provisions
- 1.1.10.20. All Plans, Technical Specifications, and Drawings
- 1.1.10.21. Any and all addenda to any of the above documents
- 1.1.10.22. Any and all change orders or written modifications to the above documents if approved in writing by the District

1.1.11. **Contract Time:** The time period stated in the Facilities Lease for Project Completion.

1.1.12. **Daily Job Report(s):** Daily Project reports prepared by the Developer's employee(s) who are present on Site, which shall include the information required herein.

1.1.13. **Day(s):** Unless otherwise designated, day(s) means calendar day(s).

1.1.14. **Developer (or "Contractor"):** The entity identified in the Facilities Lease as contracting to perform the Work to be done under this Contract, or the legal representative of such a person or persons.

1.1.15. **District (or "Owner"):** The public agency or the school district for which the Work is performed. The governing board of the District or its designees will act for the District in all matters pertaining to the Contract. The District may, at any time,

1.1.15.1. Direct the Developer to communicate with or provide notice to the Construction Manager or the Architect on matters for which the Contract Documents indicate the Developer will communicate with or provide notice to the District; and/or

1.1.15.2. Direct the Construction Manager or the Architect to communicate with or direct the Developer on matters for which the Contract Documents indicate the District will communicate with or direct the Developer.

1.1.16. **Drawings:** (or "Plans") The graphic and pictorial portions of the Contract Documents showing the design, location, scope and dimensions of the work, generally including plans, elevations, sections, details, schedules, sequence of operation, and diagrams.

1.1.17. **DSA:** Division of the State Architect.

1.1.18. **Guaranteed Project Cost (or "Contract Price"):** The total monies payable to the Developer under the terms and conditions of the Contract Documents.

1.1.19. Labor Compliance Program: (or “LCP”) If this Project is funded at least in part with State bond funds, then the LCP is the program and related documents and practices necessary for the program by which the Department of Industrial Relations Compliance Monitoring Unit, the District and/or its designee will ensure that the Developer and all Subcontractors pay prevailing wages to all workers on the Project.

1.1.20. Product(s): New material, machinery, components, equipment, fixtures and systems forming the Work, including existing materials or components required and approved by the District for reuse.

1.1.21. Product Data: Illustrations, standard schedules, performance charts, instructions, brochures, diagrams, and other information furnished by the Developer to illustrate a material, product, or system for some portion of the Work.

1.1.22. Project: The planned undertaking as provided for in the Contract Documents.

1.1.23. Project Completion: Where the Work to construct the Project is 100% complete, including all punch list items. Final DSA approval of the Project is not required for Project Completion.

1.1.24. Project Inspector (or “Inspector” or “IOR”): The individual(s) retained by the District in accordance with title 24 of the California Code of Regulations to monitor and inspect the Project.

1.1.25. Program Manager: The individual, partnership, corporation, joint venture, or any combination thereof, or its authorized representative, named as such by the District. If no Program Manager is designated for Project that is the subject of this Contract, then all references to Project Manager herein shall be read to refer to District.

1.1.26. Provide: Shall include “provide complete in place,” that is, “furnish and install,” and “provide complete and functioning as intended in place” unless specifically stated otherwise.

1.1.27. Request for Information (or “RFI”): A written request prepared by the Developer requesting that the Architect provide additional information necessary to clarify or amplify an item in the Contract Documents that the Developer believes is not clearly shown or called for in the Drawings or Specifications or other portions of the Contract Documents, or to address problems that have arisen under field conditions.

1.1.28. Request for Substitution: A request by Developer to substitute an equal or superior material, product, thing, or service for a specific material, product, thing, or service that has been designated in the Contract Documents by a specific brand or trade name.

1.1.29. Safety Orders: Written and/or verbal orders for construction issued by the California Division of Industrial Safety (“CalOSHA”) or by the United States Occupational Safety and Health Administration (“OSHA”).

1.1.30. Safety Plan: Developer’s safety plan specifically adapted for the Project. Developer’s Safety Plan shall comply with all provisions regarding Project safety, including all applicable provisions in these General Construction Provisions.

1.1.31. Samples: Physical examples that illustrate materials, products, equipment, finishes, colors, or workmanship and that, when approved in accordance with the Contract Documents, establish standards by which portions of the Work will be judged.

1.1.32. Shop Drawings: All drawings, prints, diagrams, illustrations, brochures, schedules, and other data that are prepared by the Developer, a subcontractor, manufacturer, supplier, or distributor, that illustrate how specific portions of the Work shall be fabricated or installed.

1.1.33. Site: The Project site as shown on the Drawings.

1.1.34. Specifications: That portion of the Contract Documents, Division 1 through Division 49, and all technical sections, and addenda to all of these, if any, consisting of written descriptions and requirements of a technical nature of materials, equipment, construction methods and systems, standards, and workmanship.

1.1.35. Subcontractor: A contractor and/or supplier who is under contract with the Developer or with any other subcontractor, regardless of tier, to perform a portion of the Work of the Project.

1.1.36. Submittal Schedule: The schedule of submittals as provided by Developer and approved by District.

1.1.37. Surety: The person, firm, or corporation that executes as surety the Developer's Performance Bond and Payment Bond, and must be a California admitted surety insurer as defined in the Code of Civil Procedure section 995.120.

1.1.38. Work: All labor, materials, equipment, components, appliances, supervision, coordination, and services required by, or reasonably inferred from, the Contract Documents, that are necessary for Project Completion.

1.2. Laws Concerning The Contract

Contract is subject to all provisions of the Constitution and laws of California governing, controlling, or affecting District, or the property, funds, operations, or powers of District, and such provisions are by this reference made a part hereof. Any provision required by law to be included in this Contract shall be deemed to be inserted.

1.3. No Oral Agreements

No oral agreement or conversation with any officer, agent, or employee of District, either before or after execution of Contract, shall affect or modify any of the terms or obligations contained in any of the documents comprising the Contract.

1.4. No Assignment

Except as specifically permitted in the Facilities Lease, Developer shall not assign this Contract or any part thereof including, without limitation, any services or money to become due hereunder without the prior written consent of the District. Assignment without District's prior written consent shall be null and void. Any assignment of money due or to be come due under this Contract shall be subject to a prior lien for services rendered or material supplied for performance of work called for under this Contract in favor of all persons, firms, or corporations rendering services or supplying material to the extent that claims are filed pursuant to the Civil Code, Code of Civil Procedure, Government Code, Labor Code, and/or Public Contract Code, and shall also be subject to deductions for liquidated damages or withholding of payments as determined by District in accordance with this Contract. Developer shall not assign or transfer in any manner to a Subcontractor or supplier the right to prosecute or maintain an action against the District.

1.5. Notice And Service Thereof

1.5.1. Any notice from one party to the other or otherwise under Contract shall be in writing and shall be dated and signed by the party giving notice or by a duly authorized representative of that party. Any notice shall not be effective for any purpose whatsoever unless served as indicated in the Facilities Lease.

1.6. No Waiver

The failure of District in any one or more instances to insist upon strict performance of any of the terms of this Contract or to exercise any option herein conferred shall not be construed as a waiver or relinquishment to any extent of the right to assert or rely upon any such terms or option on any future occasion. No action or failure to act by the District, Architect, or Construction Manager shall constitute a waiver of any right or duty afforded the District under the Contract, nor shall any action or failure to act constitute an approval of or acquiescence in any breach thereunder, except as may be specifically agreed in writing.

1.7. Substitutions For Specified Items

Developer shall not substitute any items identified in the Contract Documents without complying with the procedures indicated in the Contract Documents and without prior written approval of the District.

1.8. Materials and Work

1.8.1. Except as otherwise specifically stated in this Contract, Developer shall provide and pay for all materials, labor, tools, equipment, transportation, supervision, temporary constructions of every nature, and all other services, management, and facilities of every nature whatsoever necessary to execute and complete this Contract within the Contract Time.

1.8.2. Unless otherwise specified, all materials shall be new and the best of their respective kinds and grades as noted or specified, and workmanship shall be of good quality.

1.8.3. Materials shall be furnished in ample quantities and at such times as to insure uninterrupted progress of Work and shall be stored properly and protected as required.

1.8.4. For all materials and equipment specified or indicated in the Drawings, the Developer shall provide all labor, materials, equipment, and services necessary for complete assemblies and complete working systems, functioning as intended, including incidental items not indicated on Drawings, nor mentioned in the Specifications, that can legitimately and reasonably be inferred to belong to the Work described, or be necessary in good practice to provide a complete assembly or system. In all instances, material and equipment shall be installed in strict accordance with each manufacturer's most recent published recommendations and specifications.

1.8.5. Developer shall, after award of Contract by District and after relevant submittals have been approved, place orders for materials and/or equipment as specified so that delivery of same may be made without delays to the Work. Developer shall, upon demand from District, present documentary evidence showing that orders have been placed.

1.8.6. District reserves the right but has no obligation, for any neglect in complying with the above instructions, to place orders for such materials and/or equipment as it may deem advisable in order that the Work may be completed at the date specified in the Facilities Lease, and all expenses incidental to the procuring of said materials and/or equipment shall be paid for by Developer or withheld from payment(s) to Developer.

1.8.7. Developer warrants good title to all material, supplies, and equipment installed or incorporated in Work and agrees upon Project Completion to deliver the Site to District, together with all improvements and appurtenances constructed or placed thereon by it, and free from any claims, liens, or charges. Developer further agrees that neither it nor any person, firm, or corporation furnishing any materials or labor for any work covered by the Contract shall have any right to lien any portion of the

Premises or any improvement or appurtenance thereon, except that Developer may install metering devices or other equipment of utility companies or of political subdivision, title to which is commonly retained by utility company or political subdivision. In the event of installation of any such metering device or equipment, Developer shall advise District as to owner thereof.

1.8.8. Nothing contained in this Article, however, shall defeat or impair the rights of persons furnishing materials or labor under any bond given by Developer for their protection or any rights under any law permitting such protection or any rights under any law permitting such persons to look to funds due Developer in hands of District (e.g., stop payment notices), and this provision shall be inserted in all subcontracts and material contracts and notice of its provisions shall be given to all persons furnishing material for work when no formal contract is entered into for such material.

1.8.9. Title to new materials and/or equipment for the Work of this Contract and attendant liability for its protection and safety shall remain with Developer until incorporated in the Work of this Contract and Title is transferred to the District pursuant to the Facilities Lease. No part of any materials and/or equipment shall be removed from its place of storage except for immediate installation in the Work of this Contract. Developer shall keep an accurate inventory of all materials and/or equipment in a manner satisfactory to District or its authorized representative and shall, at the District's request, forward it to the District.

2. [RESERVED]

3. ARCHITECT

3.1. The Architect shall represent the District during the Project and will observe the progress and quality of the Work on behalf of the District. Architect shall have the authority to act on behalf of District to the extent expressly provided in the Contract Documents and to the extent determined by District. Architect shall have authority to reject materials, workmanship, and/or the Work whenever rejection may be necessary, in Architect's reasonable opinion, to insure the proper execution of the Contract.

3.2. Architect shall, with the District and on behalf of the District, determine the amount, quality, acceptability, and fitness of all parts of the Work, and interpret the Specifications, Drawings, and shall, with the District, interpret all other Contract Documents.

3.3. Architect shall have all authority and responsibility established by law, including title 24 of the California Code of Regulations.

3.4. Developer shall provide District and the Construction Manager with a copy of all written communication between Developer and Architect at the same time as that communication is made to Architect, including, without limitation, all RFIs, correspondence, submittals, claims, and proposed change orders.

4. CONSTRUCTION MANAGER

4.1. If a construction manager is used on this Project ("Construction Manager" or "CM"), the Construction Manager will provide administration of the Contract on the District's behalf. After execution of the Contract, all correspondence and/or instructions from Developer and/or District shall be forwarded through the Construction Manager. The Construction Manager will not be responsible for and will not have control or charge of construction means, methods, techniques, sequences, or procedures or for safety precautions in connection with the Work, which shall all remain the Developer's responsibility.

4.2. The Construction Manager, however, will have authority to reject materials and/or workmanship not conforming to the Contract Documents, as determined by the District, the Architect, and/or the Project Inspector. The Construction Manager shall also have the authority to require special inspection or testing of

any portion of the Work, whether it has been fabricated, installed, or fully completed. Any decision made by the Construction Manager, in good faith, shall not give rise to any duty or responsibility of the Construction Manager to the Developer, any Subcontractor, their agents, employees, or other persons performing any of the Work. The Construction Manager shall have free access to any or all parts of Work at any time.

4.3. If the District does not use a Construction Manager on this Project, all references to Construction Manager or CM shall be read as District.

5. INSPECTOR, INSPECTIONS, AND TESTS

5.1. Project Inspector

5.1.1. One or more Project Inspector(s), including special Project Inspector(s), as required, will be assigned to the Work by District, in accordance with requirements of title 24, part 1, of the California Code of Regulations, to enforce the building code and monitor compliance with Plans and Specifications for the Project previously approved by the DSA. Duties of Project Inspector(s) are specifically defined in section 4-342 of said part 1 of title 24.

5.1.2. No Work shall be carried on except with the knowledge and under the inspection of the Project Inspector(s). The Project Inspector(s) shall have free access to any or all parts of Work at any time. Developer shall furnish Project Inspector(s) reasonable opportunities for obtaining such information as may be necessary to keep Project Inspector(s) fully informed respecting progress and manner of work and character of materials. Inspection of Work shall not relieve Developer from an obligation to fulfill this Contract. Project Inspector(s) and the DSA are authorized to stop work whenever the Developer and/or its Subcontractor(s) are not complying with the Contract Documents. Any work stoppage by the Project Inspector(s) and/or DSA shall be without liability to the District. Developer shall instruct its Subcontractors and employees accordingly.

5.1.3. If Developer and/or any Subcontractor requests that the Project Inspector(s) perform any inspection off-site, this shall only be done if it is allowable pursuant to applicable regulations and DSA. If the off-site inspections are more frequent than are reasonable for the type of off-site inspection, those inspections shall be at the expense of the Developer.

5.2. Tests and Inspections

5.2.1. Tests and Inspections shall comply with title 24, part 1, California Code of Regulations, group 1, article 5, section 4-335, and with the provisions of the Specifications.

5.2.2. The District will select an independent testing laboratory to conduct the tests. Selection of the materials required to be tested shall be by the laboratory or the District's representative and not by the Developer. The Developer shall notify the District's representative a sufficient time in advance of its readiness for required observation or inspection.

5.2.3. The Developer shall notify the District's representative a sufficient time in advance of the manufacture of material to be supplied under the Contract Documents, that must by terms of the Contract Documents be tested, in order that the District may arrange for the testing of same at the source of supply. This notice shall be, at a minimum, seventy-two (72) hours prior to the manufacture of the material that needs to be tested. These notifications shall be submitted in all instances via hard copy and, if requested by the Project Inspector(s), also electronically via an internet-based notification/reporting system.

5.2.4. Any material shipped by the Developer from the source of supply prior to having satisfactorily passed such testing and inspection or prior to the receipt of notice from said representative that such testing and inspection will not be required, shall not be incorporated into and/or onto the Project.

5.2.5. The District will select and pay testing laboratory costs for all tests and inspections. Costs of tests of any materials found to be not in compliance with the Contract Documents shall be paid for by the District and reimbursed by the Developer or deducted from the Guaranteed Project Cost.

5.3. Costs for After Hours and/or Off Site Inspections

If the Developer performs Work outside the Inspector's regular working hours or requests the Inspector to perform inspections off Site, costs of any inspections required outside regular working hours or off Site shall be borne by the Developer and may be invoiced to the Developer by the District or the District may deduct those expenses from the next Tenant Improvement Payment.

6. DEVELOPER

Developer shall construct the Work for the Contract price including any adjustment(s) to the Guaranteed Project Cost pursuant to provisions herein regarding changes to the Guaranteed Project Cost. Except as otherwise indicated herein, Developer shall provide and pay for all labor, materials, equipment, permits, fees, licenses, facilities, transportation, taxes, and services necessary for the proper execution and Project Completion..

6.1. Status of Developer

6.1.1. Developer is and shall at all times be deemed to be an independent contractor and shall be wholly responsible for the manner in which it and its Subcontractors perform the services required of it by the Contract Documents. Nothing herein contained shall be construed as creating the relationship of employer and employee, or principal and agent, between the District, or any of the District's employees or agents, and Developer or any of Developer's Subcontractors, agents or employees. Developer assumes exclusively the responsibility for the acts of its employees as they relate to the services to be provided during the course and scope of their employment. Developer, its Subcontractors, agents, and its employees shall not be entitled to any rights or privileges of District employees. District shall be permitted to monitor the Developer's activities to determine compliance with the terms of this Contract.

6.1.2. As required by law, Developer and all Subcontractors shall be properly licensed and regulated by the Contractors State License Board, 3132 Bradshaw Road, Post Office Box 2600, Sacramento, California 98826, <http://www.cslb.ca.gov>.

6.2. Developer's Supervision

6.2.1. During progress of the Work, Developer shall keep on the Premises, and at all other appropriate locations where any Work related to the Contract is being performed, minimum staffing as indicated in **Exhibit K** to the Facilities Lease. These persons shall each comply with the following:

6.2.1.1. Each shall be an employee of the Developer, to whom the District does not object.

6.2.1.2. Each shall speak fluently English, written and verbal, and the predominant language of the Developer's employees.

6.2.2. Before commencing the Work herein, Developer shall give written notice to District of the name of its project manager and construction superintendent. Neither the Developer's project manager nor construction superintendent shall be changed except with prior written notice to District, unless the

Developer's project manager and/or construction superintendent proves to be unsatisfactory to Developer, District, any of the District's employees, agents, the Construction Manager, or the Architect, in which case, Developer shall notify District in writing or if such project manager or construction superintendent are no longer employed by Developer. The Developer's project manager and construction superintendent shall each represent Developer, and all directions given to Developer's project manager and/or construction superintendent shall be as binding as if given to Developer.

6.2.3. Developer shall give efficient supervision to Work, using its best skill and attention. Developer shall carefully study and compare all Contract Documents, Drawings, Specifications, and other instructions and shall at once report to District, Construction Manager, and Architect any error, inconsistency, or omission that Developer or its employees and Subcontractors may discover, in writing, with a copy to District's Project Inspector(s).

6.2.4. The Developer's project manager shall devote sufficient time to the Project on site, and in the Developer's home office to pre-plan activities to meet the Project schedule and fulfill all Contract obligations. This includes making timely submittals, issuing and disseminating necessary RFI's, promptly processing and distributing bulletins, change orders and payments, keeping required logs current etc. If any of these activities fall behind contract requirements or dates necessary to complete the Project on time, the Developer must provide a full time project manager on site dedicated solely to the Project, until the deficiencies are corrected.

6.2.5. The Developer shall verify all indicated dimensions before ordering materials or equipment, or before performing work. The Developer shall take field measurements, verify field conditions, and shall carefully compare such field measurements and conditions and other information known to the Developer with the Project Documents before commencing work. Errors, inconsistencies or omissions discovered shall be reported to the District at once. Upon commencement of any item of work, the Developer shall be responsible for dimensions related to such item of work and shall make any corrections necessary to make work properly fit at no additional cost to District. This responsibility for verification of dimensions is a non-delegable duty and may not be delegated to subcontractors or agents.

6.2.6. Omissions from the plans, drawings or specifications, or the misdescription of details of work which are manifestly necessary to carry out the intent of the plans, drawings and specifications, or which are customarily performed, shall not relieve the Developer from performing such omitted or misdescribed work, but they shall be performed as if fully and correctly set forth and described in the plans, drawings and specifications.

6.2.7. The Developer shall be solely responsible for the means, methods, techniques, sequences, and procedures of construction. The Developer shall be responsible to see that the finished work complies accurately with the Contract Documents.

6.3. Duty to Provide Fit Workers

6.3.1. Developer and Subcontractor(s) shall at all times enforce strict discipline and good order among their employees and shall not employ or work any unfit person or anyone not skilled in work assigned to that person. It shall be the responsibility of Developer to ensure compliance with this requirement. District may require Developer to permanently remove unfit persons from Project Site.

6.3.2. Any person in the employ of Developer or Subcontractor(s) whom District may deem incompetent or unfit shall be excluded from working on the Project and shall not again be employed on the Project except with the prior written consent of District.

6.3.3. The Developer shall furnish labor that can work in harmony with all other elements of labor employed or to be employed in the Work.

6.3.4. If Developer intends to make any change in the name or legal nature of the Developer's entity, Developer must first notify the District. The District shall determine if Developer's intended change is permissible while performing this Contract.

6.4. Personnel

6.4.1. All persons working for Developer and Subcontractor(s) shall refrain from using profane or vulgar language, or any other language that is inappropriate on the job site.

6.4.2. The Developer shall employ a full-time superintendent and necessary assistants who shall have complete authority to represent and act on behalf on the Developer on all matters pertaining to the Work. The superintendent shall be competent and have a minimum of five (5) years experience in construction supervision on projects of similar scale and complexity. The superintendent shall be satisfactory to the District and, if not satisfactory, shall be replaced by the Developer with one that is acceptable. The superintendent shall not be changed without the written consent of the District unless the superintendent ceases to be employed by the Developer.

6.4.3. The Developer shall employ a competent estimator and necessary assistants, or contract for sufficient services of an estimating consultant and to process proposed change orders. The estimator shall have a minimum of five (5) years experience in estimating. The estimator shall be satisfactory to the District and, if not satisfactory, shall be replaced by the Developer with one that is acceptable. The estimator shall not be changed without the written consent of the District unless the estimator ceases to be employed by the Developer. The Developer shall submit PCO's requested by the District within fourteen (14) calendar days.

6.4.4. The Developer shall employ a competent scheduler and necessary assistants, or contract for sufficient services of a scheduling consultant. The scheduler shall have a minimum of five (5) years experience in scheduling. The scheduler shall be satisfactory to the District and, if not satisfactory, shall be replaced by the Developer with one that is acceptable. The scheduler shall not be changed without the written consent of the District unless the scheduler ceases to be employed by the Developer.

6.4.5. Developer shall at all times enforce strict discipline and good order among Developer's employees, and shall not employ on the Project any unfit person or anyone not skilled in the task assigned.

6.4.6. If Developer or any Subcontractor on the Project site fails to comply with any provision of paragraph 6.4, the District may have the offending person(s) immediately removed from the site, and such person(s) shall be replaced within three (3) days, at no additional expense to the District. Developer, on behalf of it and its subcontractors, hereby waives any claim that the provisions of this paragraph or the enforcement thereof interferes, or has the potential to interfere, with its right to control the means and methods of its performance and duties under this Contract.

6.5. Purchase of Materials and Equipment

The Developer is required to order, obtain, and store materials and equipment sufficiently in advance of its Work at no additional cost or advance payment from District to assure that there will be no delays.

6.6. Documents on Work

6.6.1. Developer shall at all times keep on the Work Site, or at another location as the District may authorize in writing, one legible copy of all Contract Documents, including Addenda and Change Orders, and titles 19 and 24 of the California Code of Regulations, the specified edition(s) of the Uniform Building

Code, all approved Drawings, Plans, Schedules, and Specifications, and all codes referred to in the Specifications, and made part thereof. These documents shall be kept in good order and available to District, Construction Manager, Architect, Architect's representatives, the Project Inspector(s), and all authorities having jurisdiction. Developer shall be acquainted with and comply with the provisions of these titles as they relate to this Project. (See particularly the duties of Developer, title 24, part 1, California Code of Regulations, § 4-343.) Developer shall also be acquainted with and comply with all California Code of Regulations provisions relating to conditions on this Project, particularly titles 8 and 17. Developer shall coordinate with Architect and Construction Manager and shall submit its verified report(s) according to the requirements of title 24.

6.6.2. Daily Job Reports.

6.6.2.1. Developer shall maintain, at a minimum, at least one (1) set of Daily Job Reports on the Project. These must be prepared by the Developer's employee(s) who are present on Site, and must include, at a minimum, the following information:

- 6.6.2.1.1.** A brief description of all Work performed on that day.
- 6.6.2.1.2.** A summary of all other pertinent events and/or occurrences on that day.
- 6.6.2.1.3.** The weather conditions on that day.
- 6.6.2.1.4.** A list of all Subcontractor(s) working on that day,
- 6.6.2.1.5.** A list of each Developer employee working on that day and the total hours worked for each employee.
- 6.6.2.1.6.** A complete list of all major equipment on Site that day, whether in use or not.
- 6.6.2.1.7.** All complete list of all materials, supplies, and equipment delivered on that day.
- 6.6.2.1.8.** A complete list of all inspections and tests performed on that day.

6.6.2.2. Each day Developer shall provide a copy of the previous day's Daily Job Report to the District or the District's Construction Manager.

6.7. Preservation of Records

The District shall have the right to examine and audit all Daily Job Reports or other Project records of Developer's project manager(s), project superintendent(s), and/or project foreperson(s), all certified payroll records and/or related documents including, without limitation, payroll, payment, timekeeping and tracking documents; all books, estimates, records, contracts, documents, cost data, subcontract job cost reports, and other data of the Developer, any Subcontractor, and/or supplier, including computations and projections related to estimating, negotiating, pricing, or performing the Work or Contract modification, in order to evaluate the accuracy, completeness, and currency of the cost, manpower, coordination, supervision, or pricing data at no additional cost to the District. These documents may be duplicative and/or be in addition to any documents held in escrow by the District. The Developer shall make available at all reasonable times the materials described in this paragraph for the examination, audit, or reproduction until three (3) years after final payment under this Contract. Notwithstanding the provisions above, Developer shall provide any records requested by any governmental agency, if available, after the time set forth above.

6.8. Integration of Work

6.8.1. Developer shall do all cutting, fitting, patching, and preparation of Work as required to make its several parts come together properly, to fit it to receive or be received by work of other contractors, and to coordinate tolerances to various pieces of work, showing upon, or reasonably implied by, the Drawings and Specifications for the completed structure, and shall conform them as District and/or Architect may direct.

6.8.2. All cost caused by defective or ill-timed Work shall be borne by Developer, inclusive of repair work.

6.8.3. Developer shall not endanger any work performed by it or anyone else by cutting, excavating, or otherwise altering work and shall not cut or alter work of any other contractor except with consent of District.

6.9. Obtaining Licenses

Except for DSA fees or charges, Developer shall secure and pay for all of its required licenses, and certificates necessary for prosecution of Work before the date of the commencement of the Work or before the licenses, and certificates are legally required to continue the Work without interruption. The Developer shall obtain and pay, only when legally required, for all licenses and certificates required to be obtained from or issued by any authority having jurisdiction over any part of the Work included in the Contract. All final permits and certificates shall be delivered to District before demand is made for final payment.

6.10. Work to Comply With Applicable Laws and Regulations

6.10.1. Developer shall give all notices and comply with the following specific laws, ordinances, rules, and regulations and all other applicable laws, ordinances, rules, and regulations bearing on conduct of Work as indicated and specified, including but not limited to the appropriate statutes and administrative code sections. If Developer observes that Drawings and Specifications are at variance therewith, or should Developer become aware of the development of conditions not covered by Contract Documents that will result in finished Work being at variance therewith, Developer shall promptly notify District in writing and any changes deemed necessary by District shall be made as provided in Contract for changes in Work.

- 6.10.1.1.** National Electrical Safety Code, U. S. Department of Commerce
- 6.10.1.2.** National Board of Fire Underwriters' Regulations
- 6.10.1.3.** International Building Code, latest addition, and the California Code of Regulations, title 24, including amendments
- 6.10.1.4.** Manual of Accident Prevention in Construction, latest edition, published by A.G.C. of America
- 6.10.1.5.** Industrial Accident Commission's Safety Orders, State of California
- 6.10.1.6.** Regulations of the State Fire Marshall (title 19, California Code of Regulations) and Pertinent Local Fire Safety Codes
- 6.10.1.7.** Americans with Disabilities Act
- 6.10.1.8.** Education Code of the State of California
- 6.10.1.9.** Government Code of the State of California
- 6.10.1.10.** Labor Code of the State of California, division 2, part 7, Public Works and Public Agencies
- 6.10.1.11.** Public Contract Code of the State of California
- 6.10.1.12.** California Art Preservation Act
- 6.10.1.13.** U. S. Copyright Act
- 6.10.1.14.** U. S. Visual Artists Rights Act

6.10.2. Developer shall comply with all applicable mitigation measures, if any, adopted by any public agency with respect to this Project pursuant to the California Environmental Quality Act (Public Resources Code section 21000 et seq.)

6.10.3. If Developer performs any Work that it knew, or through exercise of reasonable care should have known, to be contrary to any applicable laws, ordinance, rules, or regulations, Developer shall bear all costs arising therefrom.

6.10.4. Where Specifications or Drawings state that materials, processes, or procedures must be approved by the DSA, State Fire Marshall, or other body or agency, Developer shall be responsible for satisfying requirements of such bodies or agencies.

6.11. Safety/Protection of Persons and Property

6.11.1. The Developer will be solely and completely responsible for conditions of the Work Site, including safety of all persons and property during performance of the Work. This requirement will apply continuously and not be limited to normal working hours.

6.11.2. The wearing of hard hats will be mandatory at all times for all personnel on Site. Developer shall supply sufficient hard hats to properly equip all employees and visitors.

6.11.3. Any construction review of the Developer's performance is not intended to include review of the adequacy of the Developer's safety measures in, on, or near the Work Site.

6.11.4. Implementation and maintenance of safety programs shall be the sole responsibility of the Developer.

6.11.5. The Developer shall furnish to the District a copy of the Developer's safety plan within the time frame indicated in the Contract Documents and specifically adapted for the Project.

6.11.6. Developer shall be responsible for all damages to persons or property that occur as a result of its fault or negligence in connection with the prosecution of this Contract and shall take all necessary measures and be responsible for the proper care, Project Completion and final acceptance by District. Developer shall not be responsible for damage to the Work caused by "acts of God" as defined in Public Contract Code section 7105.

6.11.7. Developer shall take, and require Subcontractors to take, all necessary precautions for safety of workers on the Project and shall comply with all applicable federal, state, local, and other safety laws, standards, orders, rules, regulations, and building codes to prevent accidents or injury to persons on, about, or adjacent to premises where Work is being performed and to provide a safe and healthful place of employment. Developer shall furnish, erect, and properly maintain at all times, all necessary safety devices, safeguards, construction canopies, signs, nets, barriers, lights, and watchmen for protection of workers and the public and shall post danger signs warning against hazards created by such features in the course of construction.

6.11.8. Hazards Control – Developer shall store volatile wastes in covered metal containers and remove them from the Site regularly, which shall be daily when appropriate for the type of hazardous wastes to be removed. Developer shall prevent accumulation of wastes that create hazardous conditions. Developer shall provide adequate ventilation during use of volatile or noxious substances.

6.11.9. Developer shall designate a responsible member of its organization on the Project, whose duty shall be to post information regarding protection and obligations of workers and other notices required under occupational safety and health laws, to comply with reporting and other occupational safety requirements, and to protect the life, safety, and health of workers. Name and position of person so designated shall be reported to District by Developer.

6.11.10. Developer shall correct any violations of safety laws, rules, orders, standards, or regulations. Upon the issuance of a citation or notice of violation by the Division of Occupational Safety and Health, Developer shall correct such violation promptly.

6.11.11. Storm Water Permits. Developer shall comply with any District storm water requirements that are approved by the District and applicable to the Project, at no additional cost to the District.

6.11.11.1. Developer shall perform the Work of the Project related to being the District's Qualified SWPPP (Storm Water Pollution Prevention Plan) Practitioner ("QSP").

6.11.11.2. As the District's QSP, Developer shall be responsible for storm water and non-storm water visual observations, sampling, and analysis per the District's SWPPP.

6.11.11.3. Developer shall strictly follow the requirements to implement all the provisions of the SWPPP including, without limitation, preparation of monitoring and recording reports and providing those to the District.

6.11.11.4. Developer's indemnity obligations as indicated in the Facilities Lease are applicable to any damages, penalties, fees, charges, or related expenses assessed or charged to the District by any water boards or agencies with jurisdiction related to compliance with the Storm Water Permits.

6.11.12. In an emergency affecting safety of life or of work or of adjoining property, Developer, without special instruction or authorization, shall act, at its discretion, to prevent such threatened loss or injury. Any compensation claimed by Developer on account of emergency work shall be determined by agreement.

6.11.13. All salvage materials will become the property of the Developer and shall be removed from the Site unless otherwise called for in the Contract Documents. However, the District reserves the right to designate certain items of value that shall be turned over to the District unless otherwise directed by District.

6.11.14. All connections to public utilities and/or existing on-site services shall be made and maintained in such a manner as to not interfere with the continuing use of same by the District during the entire progress of the Work.

6.11.15. Developer shall provide such heat, covering, and enclosures as are necessary to protect all Work, materials, equipment, appliances, and tools against damage by weather conditions, such as extreme heat, cold, rain, snow, dry winds, flooding, or dampness.

6.11.16. The Developer shall protect and preserve the Work from all damage or accident, providing any temporary roofs, window and door coverings, boxing, or other construction as required by the Architect. The Developer shall be responsible for existing structures, walks, roads, trees, landscaping, and/or improvements in working areas; and shall provide adequate protection therefore. If temporary removal is necessary of any of the above items, or damage occurs due to the Work, the Developer shall replace same at his expense with same kind, quality, and size of Work or item damaged. This shall include any adjoining property of the District and others.

6.11.17. Developer shall take adequate precautions to protect existing roads, sidewalks, curbs, pavements, utilities, adjoining property, and structures (including, without limitation, protection from settlement or loss of lateral support), and to avoid damage thereto, and repair any damage thereto caused by construction operations of the Developer.

6.11.18. Developer shall confine apparatus, the storage of materials, and the operations of workers to limits indicated by law, ordinances, permits, or directions of District, Construction Manager or Architect, and shall not interfere with the Work or unreasonably encumber Premises or overload any structure with materials. Developer shall enforce all instructions of District and Architect regarding signs, advertising, fires, and smoking, and require that all workers comply with all regulations while on Project Site.

6.11.19. Developer, Developer's employees, Subcontractors, Subcontractors' employees, or any person associated with the Work shall conduct themselves in a manner appropriate for a school site. No verbal or physical contact with neighbors, students, and faculty, profanity, or inappropriate attire or behavior will be permitted. District may require Developer to permanently remove non-complying persons from Project Site.

6.11.20. Developer shall take care to prevent disturbing or covering any survey markers, monuments, or other devices marking property boundaries or corners. If such markers are disturbed, Developer shall have a civil engineer, registered as a professional engineer in California, replace them at no cost to District.

6.11.21. In the event that the Developer enters into any agreement with owners of any adjacent property to enter upon the adjacent property for the purpose of performing the Work, Developer shall fully indemnify, defend, and hold harmless each person, entity, firm, or agency that owns or has any interest in adjacent property. The form and content of the agreement of indemnification shall be approved by the District prior to the commencement of any Work on or about the adjacent property. The Developer shall also indemnify the District as provided in the indemnification provision herein. These provisions shall be in addition to any other requirements of the owners of the adjacent property.

6.12. Working Evenings and Weekends

Developer may be required to work evenings and/or weekends at no additional cost to the District. Developer shall give the District seventy-two (72) hours notice prior to performing any evening and/or weekend work. Developer shall perform all evening and/or weekend work only upon District's approval and in compliance with all applicable rules, regulations, laws, and local ordinances including, without limitation, all noise and light limitations. Developer shall reimburse the District for any Inspector charges necessitated by the Developer's evening, weekend and/or legal holiday work, unless the District has agreed to be responsible for such costs at the District's expense in advance of the evening and/or weekend work.

6.13. Cleaning Up

6.13.1. The Developer shall provide all services, labor, materials, and equipment necessary for protecting the Work, all school occupants, furnishings, equipment, and building structure from damage until Project Completion and final acceptance by District. Dust barriers shall be provided to isolate dust and dirt from construction operations. Upon Project Completion, Developer shall clean to the original state any areas beyond the Work area that become dust laden as a result of the Work. The Developer must erect the necessary warning signs and barricades to ensure the safety of all school occupants. The Developer at all times must maintain good housekeeping practices to reduce the risk of fire damage and must make a fire extinguisher, fire blanket, and/or fire watch, as applicable, available at each location where cutting, braising, soldering, and/or welding is being performed or where there is an increased risk of fire.

6.13.2. Developer at all times shall keep Premises free from debris such as waste, rubbish, and excess materials and equipment caused by the Work. Developer shall not leave debris under, in, or about the Premises, but shall promptly remove same from the Premises on a daily basis. If Developer fails to clean up, District may do so and the cost thereof shall be charged to Developer. If Contract is for work on an existing facility, Developer shall also perform specific clean-up on or about the Premises upon request by

the District as it deems necessary for the continuing education process. Developer shall comply with all related provisions of the Specifications.

6.13.3. If the Construction Manager, Architect, or District observes the accumulation of trash and debris, the District will give the Developer a 24-hour written notice to mitigate the condition.

6.13.4. Should the Developer fail to perform the required clean-up, or should the clean-up be deemed unsatisfactory by the District, the District will then perform the clean-up. All cost associated with the clean-up work (including all travel, payroll burden, and costs for supervision) will be deducted from the Guaranteed Project Cost, or District may withhold those amounts from payment(s) to Developer.

7. SUBCONTRACTORS

7.1. Developer shall provide the District with information for all of Developer's Subcontracts and Subcontractors.

7.2. No contractual relationship exists between the District and any Subcontractor, supplier, or sub-subcontractor by reason of this Contract.

7.3. Bidding for Subcontractor Work

7.3.1. Developer is required to receive at least five (5) bona fide bids from Subcontractors for all scopes of work on the Project that constitute more than three percent (3%) of the total Project scope. Prior to the Developer seeking bids, the District and Developer may negotiate a different minimum number of bona fide bids from Subcontractors, which shall be as indicated in **Exhibit K** to the Facilities Lease.

7.3.2. Developer shall provide all bids received from all Subcontractors to the District and shall justify, to the District's satisfaction, if Developer does not choose the lowest bidding Subcontractor for a specific scope of work.

7.3.3. Developer must seek District's prior approval if it wishes to provide fewer than the minimum number of bona fide bids from Subcontractors

7.4. Developer agrees to bind every Subcontractor by terms of Contract as far as those terms are applicable to Subcontractor's work including, without limitation, all provisions and requirements of the District's Labor Compliance Program ("LCP"), if an LCP is in force on this Project. If Developer shall subcontract any part of this Contract, Developer shall be as fully responsible to District for acts and omissions of any Subcontractor and of persons either directly or indirectly employed by any Subcontractor, as it is for acts and omissions of persons directly employed by Developer. The divisions or sections of the Specifications are not intended to control the Developer in dividing the Work among Subcontractors or limit the work performed by any trade.

7.5. District's consent to, or approval of, or failure to object to, any Subcontractor under this Contract shall not in any way relieve Developer of any obligations under this Contract and no such consent shall be deemed to waive any provisions of this Contract.

7.6. Developer is directed to familiarize itself with sections 1720 through 1861 of the Labor Code of the State of California, as regards the payment of prevailing wages and related issues, and to comply with all applicable requirements therein all including, without limitation, section 1775 and the Developer's and Subcontractors' obligations and liability for violations of prevailing wage law and other applicable laws.

7.7. The Developer shall be responsible for the coordination of the trades, Subcontractors, sub-subcontractors, and material or equipment suppliers working on the Project.

7.8. Developer is solely responsible for settling any differences between the Developer and its Subcontractor(s) or between Subcontractors.

7.9. Developer must include in all of its subcontracts the assignment provisions as indicated in the Termination section of these General Construction Provisions.

8. OTHER CONTRACTS/CONTRACTORS

8.1. District reserves the right to let other contracts, and/or to perform work with its own forces, in connection with the Project. Developer shall afford other contractors reasonable opportunity for introduction and storage of their materials and execution of their work and shall properly coordinate and connect Developer's Work with the work of other contractors.

8.2. In addition to Developer's obligation to protect its own Work, Developer shall protect the work of any other contractor that Developer encounters while working on the Project.

8.3. If any part of Developer's Work depends for proper execution or results upon work of District or any other contractor, the Developer shall inspect and promptly report to the District in writing before proceeding with its Work any defects in District's or any other contractor's work that render Developer's Work unsuitable for proper execution and results. Developer shall be held accountable for damages to District for District's or any other contractor's work that Developer failed to inspect or should have inspected. Developer's failure to inspect and report shall constitute Developer's acceptance of all District's or any other contractor's work as fit and proper for reception of Developer's Work, except as to defects that may develop in District's or any other contractor's work after execution of Developer's Work.

8.4. To ensure proper execution of its subsequent work, Developer shall measure and inspect work already in place and shall at once report to the District in writing any discrepancy between that executed work and the Contract Documents.

8.5. Developer shall ascertain to its own satisfaction the scope of the Project and nature of District's or any other contracts that have been or may be awarded by District in prosecution of the Project to the end that Developer may perform this Contract in light of the other contracts, if any.

8.6. Nothing herein contained shall be interpreted as granting to Developer exclusive occupancy of the Site, the Premises, or of the Project. Developer shall not cause any unnecessary hindrance or delay to the use and/or school operation(s) of the Premises and/or to District or any other contractor working on the Project. If simultaneous execution of any contract or school operation is likely to cause interference with performance of Developer's Contract, Developer shall coordinate with those contractor(s), person(s), and/or entity(s) and shall notify the District of the resolution.

9. DRAWINGS AND SPECIFICATIONS

9.1. A complete list of all Drawings for the Project is to be found as an index on the Drawings themselves, and/or may be provided to the Developer and/or in the Table of Contents.

9.2. Materials or Work described in words that so applied have a well known technical or trade meaning shall be deemed to refer to recognized standards, unless noted otherwise.

9.3. Trade Name or Trade Term. It is not the intention of this Contract to go into detailed descriptions of any materials and/or methods commonly known to the trade under "trade name" or "trade term." The mere mention or notation of "trade name" or "trade term" shall be considered a sufficient notice to Developer that it will be required to complete the work so named, complete, finished, and operable, with all its appurtenances, according to the best practices of the trade.

9.4. The naming of any material and/or equipment shall mean furnishing and installing of same, including all incidental and accessory items thereto and/or labor therefor, as per best practices of the trade(s) involved, unless specifically noted otherwise.

9.5. Contract Documents are complementary, and what is called for by one shall be binding as if called for by all. As such, Drawings and Specifications are intended to be fully cooperative and to agree. However, if Developer observes that Drawings and Specifications are in conflict, Developer shall promptly notify District and Architect in writing, and any necessary changes shall be made as provided in the Contract Documents.

9.6. Should any question arise concerning the intent or meaning of the Contract Documents, including the Plans and Specifications, the question shall be submitted to the District for interpretation. If a conflict exists in the Contract Documents, these General Construction Provisions shall control over the Facilities Lease, which shall control over the Site Lease, which shall control over Division 1 Documents, which shall control over Division 2 through Division 49 documents, which shall control over figured dimensions, which shall control over large-scale drawings, which shall control over small-scale drawings. In no case shall a document calling for lower quality and/or quantity material or workmanship control. However, in the case of discrepancy or ambiguity solely between and among the Drawings and Specifications, the discrepancy or ambiguity shall be resolved in favor of the interpretation that will provide District with the functionally complete and operable Project described in the Drawings and Specifications. In case of ambiguity, conflict, or lack of information, District will furnish clarifications with reasonable promptness.

9.7. Drawings and Specifications are intended to comply with all laws, ordinances, rules, and regulations of constituted authorities having jurisdiction, and where referred to in the Contract Documents, the laws, ordinances, rules, and regulations shall be considered as a part of the Contract within the limits specified. Developer shall bear all expense of correcting work done contrary to said laws, ordinances, rules, and regulations and for which the Developer knew or reasonably should have known did not comply with those laws, ordinances, rules, and regulations.

9.8. Ownership of Drawings

All copies of Plans, Drawings, Designs, Specifications, and copies of other incidental architectural and engineering work, or copies of other Contract Documents furnished by District, are the property of District. They are not to be used by Developer in other work and, with the exception of signed sets of Contract Documents, are to be returned to District on request at completion of Work, or may be used by District as it may require without any additional costs to District. Neither the Developer nor any Subcontractor, or material or equipment supplier shall own or claim a copyright in the Drawings, Specifications, and other documents prepared by the Architect. District hereby grants the Developer, Subcontractors, sub-subcontractors, and material or equipment suppliers a limited license to use applicable portions of the Drawings prepared for the Project in the execution of their Work under the Contract Documents.

10. DEVELOPER'S SUBMITTALS AND SCHEDULES

10.1. Construction Schedule

The Developer shall prepare a Construction Schedule that complies with the construction schedule attached to the Facilities Lease as **Exhibit F** ("Construction Schedule") and shall provide all schedules and construction progress documentation as required in the Contract Documents. All items on the Schedule of Values must have a specific completion date on the Construction Schedule, or District has approved the Construction Schedule and the Construction Schedule is loaded and detailed as required by the Contract Documents.

10.2. Schedule of Values

The Developer has provided and the District has approved a schedule of values for all of the Work, which includes quantities and prices of items aggregating the Guaranteed Project Cost and subdivided into component parts. This schedule of values includes, at a minimum, the following information and the following structure:

10.2.1.1. Divided into at least the following categories:

- 10.2.1.1.1.** Overhead and profit;
- 10.2.1.1.2.** Supervision;
- 10.2.1.1.3.** General conditions;
- 10.2.1.1.4.** Layout;
- 10.2.1.1.5.** Mobilization;
- 10.2.1.1.6.** Submittals;
- 10.2.1.1.7.** Bonds and insurance;
- 10.2.1.1.8.** Closeout documentation;
- 10.2.1.1.9.** Demolition;
- 10.2.1.1.10.** Installation;
- 10.2.1.1.11.** Rough-in;
- 10.2.1.1.12.** Finishes;
- 10.2.1.1.13.** Testing;
- 10.2.1.1.14.** Punch list and acceptance.

10.2.1.2. Divided by each of the following areas:

- 10.2.1.2.1.** Site work;
- 10.2.1.2.2.** By each building;
- 10.2.1.2.3.** By each floor.
- 10.2.1.2.4.** By division of work.

10.2.1.3. The schedule of values shall not provide for values any greater than the following percentages of the Guaranteed Project Cost:

- 10.2.1.3.1.** Mobilization and layout combined to equal not more than 1%;
- 10.2.1.3.2.** Submittals, samples and shop drawings combined to equal not more than 2%;
- 10.2.1.3.3.** Bonds and insurance combined to equal not more than 3%.
- 10.2.1.3.4.** Punchlist and acceptance value shall not be no less than 1%.
- 10.2.1.3.5.** No Schedule of Value (except noted above) shall be greater than 1%.

10.2.1.4. Closeout Documentation shall have a value in the schedule of values of not less than 2%.

10.2.1.5. The Schedule Of Values shall not be modified or amended by the Developer without the prior consent and approval of the District, which may be granted or withheld in the sole discretion of the District.

10.3. Safety Plan. Developer's Safety Plan specifically adapted for the Project. Developer's Safety Plan shall comply with the following requirements and shall be submitted to the District for information purposes only:

10.3.1. All applicable requirements of California Division of Industrial Safety ("CalOSHA") and/or of the United States Occupational Safety and Health Administration ("OSHA").

10.3.2. All provisions regarding Project safety, including all applicable provisions in these General Construction Provisions.

10.3.3. Developer's Safety Plan shall be in English and in the language(s) of the Developer's and its Subcontractors' employees.

10.4. Complete Subcontractor List. The name, address, telephone number, facsimile number, California State Developers License number, classification, and monetary value of all Subcontracts for parties furnishing labor, material, or equipment for Project Completion, plus all information required in the Contract Documents. This includes the subcontractor Bid and fully executed Contract.

10.5. Developer must provide all schedules both in hard copy and electronically, in a format (e.g., Microsoft Project or Primavera) approved in advance by the District.

10.6. The District will review the schedules submitted and the Developer shall make changes and corrections in the schedules as requested by the District and resubmit the schedules until approved by the District.

10.7. The District shall have the right at any time to revise the schedule of values if, in the District's sole opinion, the schedule of values does not accurately reflect the value of the Work performed.

10.8. Monthly Progress Schedule(s)

10.8.1. Developer shall provide Monthly Progress Schedule(s) to the District. A Monthly Progress Schedule shall update the approved Construction Schedule or the last Monthly Progress Schedule, showing all work completed and to be completed. The monthly Progress Schedule shall be in a format acceptable to the District and contain a written narrative of the progress of work that month and any changes, delays, or events that may affect the work. The process for District approval of the Monthly Progress Schedule shall be the same as the process for approval of the Construction Schedule.

10.8.2. Developer shall also submit Monthly Progress Schedule(s) with all payment applications.

10.9. Material Safety Data Sheets (MSDS)

Developer is required to ensure Material Safety Data Sheets are available in a readily accessible place at the Work Site for any material requiring a Material Safety Data Sheet per the Federal "Hazard Communication" standard, or employees right to know law. The Developer is also required to ensure proper labeling on substance brought onto the job site and that any person working with the material or within the general area of the material is informed of the hazards of the substance and follows proper handling and protection procedures. Two additional copies of the Material Safety Data Sheets shall also be submitted directly to the District.

10.10. Logistics Plan. Developer shall provide a staging and logistics plan identifying laydown areas, loading and unloading areas, crane locations, fence locations, temporary utility connections, trailer locations, and emergency evacuation meeting area. This Logistics Plan must be approved by the District prior to the Developer mobilizing on the Site

11. SITE ACCESS, CONDITIONS, AND REQUIREMENTS

11.1. Site Investigation

Developer has made a careful investigation of the Site and is familiar with the requirements of the Contract and has accepted the known existing conditions of the Site.

11.2. Soils Investigation Report & Site Due Diligence

11.2.1. When a soils investigation report obtained from test holes at Site is available, that report shall be available to the Developer but shall not be a part of this Contract. Any information obtained from that report or any information given on Drawings as to subsurface soil condition or to elevations of existing grades or elevations of underlying rock is approximate only, is not guaranteed, does not form a part of this Contract. Developer may reasonably rely thereon, however the Districts makes no warranty regarding the completeness or accuracy of any such report or other information regarding subsurface conditions. Developer acknowledges that it has made visual examination of Site and has made whatever tests Developer deems appropriate to determine underground condition of soil.

11.2.2. If Developer encounters subsurface or latent conditions at Site materially differing from those shown on Drawings or indicated in Specifications, or for unknown conditions of an unusual nature that differ materially from those ordinarily encountered in the Work of the character provided for in the Contract Documents, Developer shall give notice to the District immediately before conditions are disturbed and in no event later than ten (10) days after first observance of the conditions.

11.2.2.1. The District will promptly investigate such conditions and, if they differ materially and cause an increase or decrease in Developer's cost of, or time required for, performance of any part of the Work, will equitably adjustment the Contract Sum or Contract Time, or both.

11.2.2.2. If the District determines that the conditions at the site are not materially different from those indicated in the Contract Documents and that no change in the terms of the Contract is justified, the District will notify Developer in writing, stating the reasons.

11.2.2.3. If after receiving the response, Developer still intends to pursue a Claim, it shall provide written notice within ten (10) days after it has received the decision.

11.2.2.4. Conditions will not be qualified as concealed or unknown if they were readily visible or reasonably observable.

11.2.3. Developer's 's Diligence. Developer's agreement to the Contract Price confirms that it has made a careful examination of the Contract Documents, that it has a complete understanding of the nature, extent, and location of Work to be performed and that it expressly represents that it has fully completed the following:

11.2.3.1. Developer has visited the Project Site, if required, and has examined thoroughly and understood the nature and extent of the Contract Documents, Work, Site, locality, actual conditions, as-built conditions, and all local conditions and federal, state and local laws, and regulations that in any manner may affect cost, progress, performance, or furnishing of Work or that relate to any aspect of the means, methods, techniques, sequences, or procedures of construction to be employed by Developer and safety precautions and programs incident thereto;

11.2.3.2. Developer has conducted or obtained and has understood all examinations, investigations, explorations, tests, reports, and studies that pertain to the subsurface conditions, as-built conditions, underground facilities, and all other physical conditions at or contiguous to the Site or otherwise that may affect the cost, progress, performance, or furnishing of Work, as Developer considers necessary for the performance or furnishing of Work at the Guaranteed Project Cost, within the Contract Time, and in accordance with the other terms and conditions of Contract Documents, including specifically the provisions of the General Construction Provisions; and no additional examinations, investigations, explorations, tests, reports, studies, or similar information or data are or will be required by Developer for such purposes;

11.2.3.3. Developer has correlated its knowledge and the results of all such observations, examinations, investigations, explorations, tests, reports, and studies with the terms and conditions of the Contract Documents;

11.2.3.4. Developer has given the District prompt written notice of all conflicts, errors, ambiguities, or discrepancies that it has discovered in or among the Contract Documents and the actual conditions, and the written resolution thereof by the District is acceptable to Developer;

11.2.3.5. Developer has made a complete disclosure in writing to the District of all facts bearing upon any possible interest, direct or indirect, that Developer believes any representative of the District or other officer or employee of the District presently has or will have in this Contract or in the performance thereof or in any portion of the profits thereof;

11.2.3.6. Developer is charged with all information and knowledge that a reasonable contractor would ascertain from having performed this required work, investigation, research, and analysis. the Guaranteed Project Cost includes entire cost of all work "incidental" to completion of the Work.

11.2.3.7. Conditions Shown on the Contract Documents: Information as to underground conditions, as-built conditions, or other conditions or obstructions, indicated in the Contract Documents, e.g., on Drawings or in Specifications, has been obtained with reasonable care, and has been recorded in good faith. However, District only warrants, and Developer may only rely, on the accuracy of limited types of information.

11.2.3.7.1. As to above-ground conditions or as-built conditions shown or indicated in the Contract Documents, there is no warranty, express or implied, or any representation express or implied, that such information is correctly shown or indicated. This information is verifiable by independent investigation and Developer is required to make such verification. Developer shall rely on the results of its own independent investigation. Developer shall not rely on District-supplied information regarding above-ground conditions or as-built conditions.

11.2.3.7.2. As to any subsurface condition shown or indicated in the Contract Documents, Developer may rely only upon the general accuracy of actual reported depths, actual reported character of materials, actual reported soil types, actual reported water conditions, or actual obstructions shown or indicated. District is not responsible for the completeness of such information for preparing a proposal or construction; nor is District responsible in any way for any conclusions or opinions of Developer drawn from such information; nor is District responsible for subsurface conditions that are not specifically shown (for example, District is not responsible for soil conditions in areas contiguous to areas where a subsurface condition is shown).

11.2.4. Conditions Shown in Reports and Drawings Supplied for Informational Purposes: Reference is made to the document entitled Geotechnical Data (if attached), and the document entitled Existing Conditions (if attached), for identification of:

11.2.4.1. Subsurface Conditions: Those reports of explorations and tests of subsurface conditions at or contiguous to the Project Site that have been utilized by Architect in preparing the Contract Documents; and

11.2.4.2. Physical Conditions: Those drawings of physical conditions in or relating to existing surface or subsurface structures at or contiguous to the Project Site that has been utilized by Architect in preparing the Contract Documents.

11.2.4.3. These reports and drawings are **not** Contract Documents and, except for any “technical” data regarding subsurface conditions specifically identified in Geotechnical Data and Existing Conditions, and underground facilities data, Developer may not in any manner rely on the information in these reports and drawings. Subject to the foregoing, Developer must make its own independent investigation of all conditions affecting the Work and must not rely on information provided by District.

11.3. Access to Work

District and its representatives shall at all times have access to Work wherever it is in preparation or progress, including storage and fabrication. Developer shall provide safe and proper facilities for such access so that District's representatives may perform their functions.

11.4. Layout and Field Engineering

11.4.1. All field engineering required for layout of this Work and establishing grades for earthwork operations shall be furnished by Developer at its expense. This Work shall be done by a qualified, California-registered civil engineer and/or surveyor (as appropriate) approved in writing by District and Architect.

11.4.2. The Developer shall be responsible for having ascertained pertinent local conditions such as location, accessibility, and general character of the Site and for having satisfied itself as to the conditions under which the Work is to be performed. District shall not be liable for any claim for allowances because of Developer's error or negligence in acquainting itself with the conditions at the Site.

11.4.3. Developer shall protect and preserve established benchmarks and monuments and shall make no changes in locations without the prior written approval of District. Developer shall replace any benchmarks or monuments that are lost or destroyed subsequent to proper notification of District and with District's approval.

11.5. Utilities & Sanitary Facilities

Developer shall provide all required utilities and sanitary facilities.

11.6. Surveys

Developer shall provide surveys done by a California-licensed civil engineer surveyor to determine locations of construction, grading, and site work as required to perform the Work.

11.7. Regional Notification Center

The Developer, except in an emergency, shall contact the appropriate regional notification center at least two (2) days prior to commencing any excavation if the excavation will be conducted in an area or in a private easement that is known, or reasonably should be known, to contain subsurface installations other than the underground facilities owned or operated by the District, and obtain an inquiry identification number from that notification center. No excavation shall be commenced and/or carried out by the Developer unless an inquiry identification number has been assigned to the Developer or any Subcontractor and the Developer has given the District the identification number. Any damages arising from Developer's failure to make appropriate notification shall be at the sole risk and expense of the

Developer. Any delays caused by failure to make appropriate notification shall be at the sole risk of the Developer and shall not be considered for an extension of the Contract time.

11.8. Existing Utility Lines

11.8.1. Pursuant to Government Code section 4215, District assumes the responsibility for removal, relocation, and protection of main or trunk utility lines and facilities located on the construction Site at the time of commencement of construction under this Contract with respect to any such utility facilities that are not identified in the Plans and Specifications. Developer shall not be assessed for liquidated damages for delay in Project Completion caused by failure of District or the owner of a utility to provide for removal or relocation of such utility facilities.

11.8.2. Locations of existing utilities provided by District shall not be considered exact, but approximate within reasonable margin and shall not relieve Developer of responsibilities to exercise reasonable care nor costs of repair due to Developer's failure to do so. District shall compensate Developer for the costs of locating, repairing damage not due to the failure of Developer to exercise reasonable care, and removing or relocating such utility facilities not indicated in the Plans and Specifications with reasonable accuracy, and for equipment necessarily idle during such work.

11.8.3. No provision herein shall be construed to preclude assessment against Developer for any other delays in Project Completion. Nothing in this Article shall be deemed to require District to indicate the presence of existing service laterals, appurtenances, or other utility lines, within the exception of main or trunk utility lines. Whenever the presence of these utilities on the Site of the construction Project can be inferred from the presence of other visible facilities, such as buildings, meter junction boxes, on or adjacent to the Site of the construction.

11.8.4. If Developer, while performing Work under this Contract, discovers utility facilities not identified by District in Contract Plans and Specifications, Developer shall immediately notify the District and the utility in writing. The cost of repair for damage to above-mentioned visible facilities without prior written notification to the District shall be borne by the Developer.

11.9. Notification

Developer understands, acknowledges and agrees that the purpose for prompt notification to the District pursuant to these provisions is to allow the District to investigate the condition(s) so that the District shall have the opportunity to decide how the District desires to proceed as a result of the condition(s). Accordingly, failure of Developer to promptly notify the District in writing, pursuant to these provisions, shall constitute Developer's waiver of any claim for damages or delay incurred as a result of the condition(s).

11.10. Hazardous Materials

11.10.1. District is the generator of any hazardous materials that are on the Site and which are not brought to the Site by Developer. Developer is solely responsible for the exacerbation of Hazardous Materials. The cost of assessment, storage, and disposal of such shall be included in the Work.

11.10.2. Developer shall give written notice to District, Construction Manager, and Architect promptly, before any of the following conditions are disturbed, and in no event later than twenty-four (24) hours after first observance, of any:

11.10.2.1. Material that Developer believes may be material that is hazardous waste or hazardous material, as defined in section 25117 of the Health and Safety Code, that is required to be removed to a Class I, Class II, or Class III disposal site in accordance with provisions of existing law;

11.10.2.2. Other material that may present a substantial danger to persons or property exposed thereto in connection with Work at the Project Site.

11.10.3. Developer's written notice shall indicate whether the hazardous waste or material was shown or indicated in the Contract Documents to be within the scope of Work, and whether the materials were brought to the site by Developer, its Subcontractors, suppliers, or anyone else for whom Developer is responsible. As used in this section the term "hazardous materials" shall include, without limitation, asbestos, lead, Polychlorinated biphenyl (PCB), petroleum and related hydrocarbons, and radioactive material.

11.10.4. In response to Developer's written notice, the District shall investigate the identified conditions.

11.10.5. If District determines that conditions do not involve hazardous materials or that no change in terms of Contract is justified, District shall so notify Developer in writing, stating reasons. If District and Developer cannot agree on whether conditions justify an adjustment in Contract Price or Contract Time, or on the extent of any adjustment, Developer shall proceed with the Work as directed by District.

11.10.6. If after receipt of notice from District, Developer does not agree to resume Work based on a reasonable belief it is unsafe, or does not agree to resume Work under special conditions, then District may order that portion of Work connected with the hazardous condition or affected area, be deleted from the Work, or performed by others, or District may invoke its rights to terminate the Contract in whole or in part. District will determine entitlement to or the amount or extent of an adjustment, if any, in Contract Price or Contract Time as a result of deleting such portion of Work, or performing the Work by others.

11.10.7. If Developer stops Work in connection with any hazardous condition and in any area affected thereby, Developer shall immediately redeploy its workers, equipment, and materials, as necessary, to other portions of the Work to minimize delay and disruption.

11.10.8. Additional Warranties and Representations

11.10.8.1. Developer represents and warrants that it, its employees, and its subcontractors and their employees, shall at all times have the required levels of familiarity with the Project Site and the Work, training, and ability to comply fully with all applicable law and contract requirements for safe and expeditious performance of the Work, including whatever training is or may be required regarding the activities to be performed (including, but not limited to, all training required to address adequately the actual or potential dangers of Contract performance).

11.10.8.2. Developer represents and warrants that it, its employees, and its subcontractors and their employees, shall at all times have and maintain in good standing any and all certifications and licenses required by applicable federal, state, and other governmental and quasi-governmental requirements applicable to the Work.

11.10.8.3. Developer represents and warrants that it has studied carefully all requirements of the Specifications regarding procedures for demolition, hazardous waste abatement, or safety practices, specified in the Contract, and prior to submitting its bid, has either (a) verified to its satisfaction that the specified procedures are adequate and sufficient to achieve the results intended by the Contract Documents, or (b) by way of approved "or equal" request or request for clarification and written Addenda, secured changes to the specified procedures sufficient to achieve the results intended by the Contract Documents. Developer accepts the risk that any specified procedure will result in a completed Project in full compliance with the Contract Documents.

11.10.9. Monitoring and Testing

11.10.9.1. District reserves the right, in its sole discretion, to conduct air monitoring, earth monitoring, Work monitoring, and any other tests (in addition to testing required under the agreement or applicable law), to monitor Contract requirements of safe and statutorily compliant work methods and (where applicable) safe re-entry level air standards under state and federal law upon completion of the job, and compliance of the work with periodic and final inspection by public and quasi-public entities having jurisdiction.

11.10.9.2. Developer acknowledges that District has the right to perform, or cause to be performed, various activities and tests including, but not limited to, pre-abatement, during abatement, and post-abatement air monitoring, that District shall have no obligation to perform said activities and tests, and that a portion of said activities and tests may take place prior to the completion of the Work by Developer. In the event District elects to perform these activities and tests, Developer shall afford District ample access to the Site and all areas of the Work as may be necessary for the performance of these activities and tests. Developer will include the potential impact of these activities or tests by District in the Contract Price and the Scheduled Completion Date.

11.10.9.3. Notwithstanding District's rights granted by this paragraph, Developer may retain its own industrial hygiene consultant at Developer's own expense and may collect samples and perform tests including, but not limited to, pre-abatement, during abatement, and post-abatement personal air monitoring, and District reserves the right to request documentation of all such activities and tests performed by Developer relating to the Work and Developer shall provide that documentation immediately upon request, but in no event later than **THREE (3)** days upon request.

11.10.10. Compliance with Laws

11.10.10.1. Developer shall perform safe, expeditious, and orderly work in accordance with the best practices and the highest standards in the hazardous waste abatement, removal, and disposal industry, the applicable law, and the Contract Documents, including, but not limited to, all responsibilities relating to the preparation and return of waste shipment records, all requirements of the law, delivering of all requisite notices, and obtaining all necessary governmental and quasi-governmental approvals.

11.10.10.2. Developer represents that it is familiar with and shall comply with all laws applicable to the Work or completed Work including, but not limited to, all federal, state, and local laws, statutes, standards, rules, regulations, and ordinances applicable to the Work relating to:

11.10.10.2.1. The protection of the public health, welfare and environment;

11.10.10.2.2. Storage, handling, or use of asbestos, PCB, lead, petroleum based products or other hazardous materials;

11.10.10.2.3. The generation, processing, treatment, storage, transport, disposal, destruction, or other management of asbestos, PCB, lead, petroleum, or hazardous waste materials or other waste materials of any kind; and

11.10.10.2.4. The protection of environmentally sensitive areas such as wetlands and coastal areas.

11.10.11. Disposal

11.10.11.1. Developer has the sole responsibility for determining current waste storage, handling, transportation, and disposal regulations for the Project Site and for each waste disposal facility. Developer must comply fully at its sole cost and expense with these regulations and any applicable law. District may, but is not obligated to, require submittals with this information for it to review consistent with the Contract Documents.

11.10.11.2. Developer shall develop and implement a system acceptable to District to track hazardous waste from the Project Site to disposal, including appropriate "Hazardous Waste Manifests" on the EPA form, so that District may track the volume of waste deposited in each landfill and receive from each facility a certificate of receipt.

11.10.11.3. Developer shall provide District with the name and address of each waste disposal facility prior to any disposal, and District shall have the right to reject any proposed disposal facility. Developer shall not use any disposal facility to which District has objected. Developer shall document actual disposal or destruction of waste at a designated facility by completing a disposal certificate or certificate of destruction forwarding the original to District.

11.10.12. Permits

11.10.12.1. Before performing any of the Work, and at such other times as may be required by applicable law, Developer shall deliver all requisite notices and obtain the approval of all governmental and quasi-governmental authorities having jurisdiction over the Work. Developer shall submit evidence satisfactory to District that Developer and any disposal facility:

11.10.12.1.1. Have obtained all required permits, approvals, and the like in a timely manner both prior to commencement of the Work and thereafter as and when required by applicable law, and

11.10.12.1.2. Are in compliance with all such permits, approvals and the regulations.

For example, before commencing any work in connection with the Work involving asbestos-containing materials, or PCBs, or other hazardous materials subject to regulation, Developer agrees to provide the required notice of intent to renovate or demolish to the appropriate state or federal agency having jurisdiction, by certified mail, return receipt requested, or by some other method of transmittal for which a return receipt is obtained, and to send a copy of that notice to District. Developer shall not conduct any Work involving asbestos-containing materials or PCBs unless Developer has first confirmed that the appropriate agency having jurisdiction is in receipt of the required notification. All permits, licenses, and bonds that are required by governmental or quasi-governmental authorities, and all fees, deposits, tap fees, offsite easements, and asbestos and PCB disposal facilities expenses necessary for the prosecution of the Work, shall be procured and paid for by Developer. Developer shall give all notices and comply with the all applicable laws bearing on the conduct of the Work as drawn and specified. If Developer observes or reasonably should have observed that Plans and Specifications and other Contract Documents are at variance therewith, it shall be responsible for promptly notifying District in writing of such fact. If Developer performs any Work contrary to applicable laws, it shall bear all costs arising therefrom.

11.10.12.2. In the case of any permits or notices held in District's name or of necessity to be made in District's name, District shall cooperate with Developer in securing the permit or giving the notice, but the Developer shall prepare for District review and execution upon approval, all necessary applications, notices, and other materials.

11.11. No Signs

Neither the Developer nor any other person or entity shall display any signs not required by law or the Contract Documents at the Site, fences trailers, offices, or elsewhere on the Site without specific prior written approval of the District.

12. TRENCHES

12.1. Trenches Greater Than Five Feet

Pursuant to Labor Code section 6705, if the Guaranteed Project Cost exceeds \$25,000 and involves the excavation of any trench or trenches five (5) feet or more in depth, the Developer shall, in advance of excavation, promptly submit to the District and/or a registered civil or structural engineer employed by the District or Architect, a detailed plan showing the design of shoring for protection from the hazard of caving ground during the excavation of such trench or trenches.

12.2. Excavation Safety

If such plan varies from the Shoring System Standards established by the Construction Safety Orders, the plan shall be prepared by a registered civil or structural engineer, but in no case shall such plan be less effective than that required by the Construction Safety Orders. No excavation of such trench or trenches shall be commenced until said plan has been accepted by the District or by the person to whom authority to accept has been delegated by the District.

12.3. No Tort Liability of District

Pursuant to Labor Code section 6705, nothing in this Article shall impose tort liability upon the District or any of its employees.

12.4. No Excavation Without Permits

The Developer shall not commence any excavation Work until it has secured all necessary permits including the required CAL OSHA excavation/shoring permit. Any permits shall be prominently displayed on the Site prior to the commencement of any excavation.

12.5. Discovery of Hazardous Waste and/or Unusual Conditions

12.5.1. Pursuant to Public Contract Code section 7104, if the Work involves digging trenches or other excavations that extend deeper than four feet below the Surface, the Developer shall promptly, and before the following conditions are disturbed, notify the District, in writing, of any:

12.5.1.1. Material that the Developer believes may be material that is hazardous waste, as defined in section 25117 of the Health and Safety Code, that is required to be removed to a Class I, Class II, or Class III disposal site in accordance with provisions of existing law.

12.5.1.2. Subsurface or latent physical conditions at the Site differing from those indicated.

12.5.1.3. Unknown physical conditions at the Site of any unusual nature, different materially from those ordinarily encountered and generally recognized as inherent in work of the character provided for in the Contract.

12.5.2. The District shall promptly investigate the conditions, and if it finds that the conditions do materially so differ, or do involve hazardous waste, and cause a decrease or increase in the Developer's cost of, or the time required for, performance of any part of the Work, shall issue a Change Order under the procedures described herein.

12.5.3. In the event that a dispute arises between District and the Developer whether the conditions materially differ, or involve hazardous waste, or cause a decrease or increase in the Developer's cost of, or time required for, performance of any part of the Work, the Developer shall not be excused from any scheduled completion date provided for by the Contract, but shall proceed with all work to be performed under the Contract. The Developer shall retain any and all rights provided either by Contract or by law that pertain to the resolution of disputes and protests.

13. INSURANCE AND BONDS

13.1. Developer's Insurance. The Developer shall comply with the insurance requirements as indicated in the Facilities Lease.

13.2. Contract Security - Bonds

13.2.1. Developer shall furnish two surety bonds issued by a California admitted surety insurer as follows:

13.2.1.1. Performance Bond: A bond in an amount at least equal to one hundred percent (100%) of Contract Price as security for faithful performance of this Contract.

13.2.1.2. Payment Bond: A bond in an amount at least equal to one hundred percent (100%) of the Contract Price as security for payment of persons performing labor and/or furnishing materials in connection with this Contract.

13.2.2. Cost of bonds shall be included in the Guaranteed Project Cost.

13.2.3. All bonds related to this Project shall be on the forms provided in the Contract Documents and shall comply with all requirements of the Contract Documents.

14. WARRANTY/GUARANTEE/INDEMNITY

14.1. Warranty/Guarantee

14.1.1. The Developer shall obtain and preserve for the benefit of the District, manufacturer's warranties on materials, fixtures, and equipment incorporated into the Work.

14.1.2. In addition to guarantees required elsewhere, Developer shall, and hereby does guarantee and warrant all Work furnished on the job against all defects for a period of **ONE (1)** year after the later of the following dates:

14.1.2.1. Project Completion,

14.1.2.2. The commissioning date for the Project, if any.

At the District's sole option, Developer shall repair or replace any and all of that Work, together with any other Work that may be displaced in so doing, that may prove defective in workmanship and/or materials within a **ONE (1)** year period from date of completion as defined above without expense whatsoever to District. In the event of failure of Developer and/or Surety to commence and pursue with diligence said replacements or repairs within ten (10) days after being notified in writing, Developer and Surety hereby acknowledge and agree that District is authorized to proceed to have defects repaired and made good at expense of Developer and/or Surety who hereby agree to pay costs and charges therefore immediately on demand.

14.1.3. If, in the opinion of District, defective work creates a dangerous condition or requires immediate correction or attention to prevent further loss to District or to prevent interruption of operations of District, District will attempt to give the notice required above. If Developer or Surety cannot be contacted or neither complies with District's request for correction within a reasonable time as determined by District, District may, notwithstanding the above provision, proceed to make any and all corrections and/or provide attentions the District believes are necessary. The costs of correction or attention shall be charged against Developer and Surety of the guarantees provided in this Article or elsewhere in this Contract.

14.1.4. The above provisions do not in any way limit the guarantees on any items for which a longer guarantee is specified or on any items for which a manufacturer gives a guarantee for a longer period. Developer shall furnish to District all appropriate guarantee or warranty certificates as indicated in the Specifications or upon request by District.

14.1.5. Nothing herein shall limit any other rights or remedies available to District.

14.2. Indemnity Developer shall indemnify the District as indicated in the Facilities Lease.

15. TIME

15.1. Computation of Time / Adverse Weather

15.1.1. The Developer will only be allowed a time extension for Adverse Weather conditions if requested by Developer and only if all of the following conditions are met:

15.1.1.1. The weather conditions constitute Adverse Weather, as defined herein;

15.1.1.2. Developer can verify that the Adverse Weather caused delays in excess of five hours of the indicated labor required to complete the scheduled tasks of Work on the day affected by the Adverse Weather;

15.1.1.3. The Developer’s crew is dismissed as a result of the Adverse Weather; and

15.1.1.4. The number of days of delay for the month exceeds the following parameters. The District and Developer may negotiate a different minimum number of days, which shall be as indicated in **Exhibit K** to the Facilities Lease:

January	<u>11</u>	July	<u>0</u>
February	<u>10</u>	August	<u>0</u>
March	<u>10</u>	September	<u>1</u>
April	<u>6</u>	October	<u>4</u>
May	<u>3</u>	November	<u>7</u>
June	<u>1</u>	December	<u>10</u>

15.1.2. A day-for-day extension will only be allowed for those days in excess of those indicated herein.

15.1.3. The Contract Time has been determined with consideration given to the average climate weather conditions prevailing in the County in which the Project is located.

15.2. Hours of Work

Work shall be performed during regular working hours as permitted by the appropriate governmental agency except that in the event of an emergency, or when required to complete the Work in accordance with job progress, Work may be performed outside of regular working hours with the advance written consent of the District and approval of any required governmental agencies.

15.3. Progress and Project Completion

15.3.1. Time of the Essence

Time limits stated in the Contract Documents are of the essence to the Contract. By executing the Facilities Lease, the Developer confirms that the Contract Time is a reasonable period for Project Completion.

15.3.2. No Commencement Without Insurance

The Developer shall not commence operations on the Project or elsewhere prior to the effective date of insurance and bonds. The date of commencement of the Work shall not be changed by the effective date of such insurance. If Developer commences Work without insurance and bonds, all Work is performed at Developer's peril and shall not be compensable until and unless Developer secures bonds and insurance pursuant to the terms of the Contract Documents and subject to District claim for damages.

15.3.3. Sufficient Forces

Developer and Subcontractors shall continuously furnish sufficient forces to ensure the prosecution of the Work in accordance with the Construction Schedule to obtain Project Completion within the Contract Time.

15.4. Schedule

Developer shall provide to District, Construction Manager, and Architect a schedule in conformance with the Contract Documents and as required in these General Construction Provisions.

15.5. Expeditious Completion

The Developer shall proceed expeditiously with adequate forces and shall achieve Completion within the Contract Time.

16. EXTENSIONS OF TIME – LIQUIDATED DAMAGES

16.1. Liquidated Damages

Developer and District hereby agree that the exact amount of damages for failure to complete the Work within the time specified is extremely difficult or impossible to determine. If the Work is not completed within the time specified in the Contract Documents, it is understood that the District will suffer damage. It being impractical and unfeasible to determine the amount of actual damage, it is agreed the Developer shall pay to District as fixed and liquidated damages, and not as a penalty, the amount set forth in the Facilities Lease for each calendar day of delay beyond the Contract Time. Developer and its Surety shall be liable for the amount thereof pursuant to Government Code section 53069.85.

16.2. Excusable Delay

16.2.1. Developer shall not be charged for liquidated damages because of any delays beyond the Contract Time which are not the fault of Developer or its Subcontractors, including acts of God as defined in Public Contract Code section 7105, acts of enemy, epidemics, and quarantine restrictions. Developer shall, within five (5) calendar days of any delay, notify District in writing of causes of delay including documentation and facts explaining the delay. District shall review the facts and extent of any delay and shall grant extension(s) of time for completing Work when, in its judgment, the findings of fact justify an extension. Extension(s) of time shall apply only to that portion of Work affected by delay, and shall not apply to other portions of Work not so affected. An extension of time may only be granted if Developer has timely submitted the Construction Schedule as required herein.

16.2.2. Developer shall notify the District pursuant to the claims provisions in these General Construction Provisions of any anticipated delay and its cause. Following submission of a claim, the District may determine whether the delay is to be considered avoidable or unavoidable, how long it continues, and to what extent the prosecution and Project Completion might be delayed thereby.

16.2.3. In the event the Developer requests an extension of Contract Time for unavoidable delay, such request shall be submitted in accordance with the provisions in the Contract Documents governing changes in Work. When requesting time, requests must be submitted with full justification and documentation. If the Developer fails to submit justification, it waives its right to a time extension at a later date. Such justification must be based on the official Construction Schedule as updated at the time of occurrence of the delay or execution of Work related to any changes to the Scope of Work. Any claim for delay must include the following information as support, without limitation:

16.2.3.1. The duration of the activity relating to the changes in the Work and the resources (manpower, equipment, material, etc.) required to perform the activities within the stated duration.

16.2.3.2. Specific logical ties to the Construction Schedule for the proposed changes and/or delay showing the activity/activities in the Construction Schedule that are affected by the change and/or delay. (A portion of any delay of seven (7) days or more must be provided.)

16.2.3.3. A revised Construction Schedule must be submitted.

16.3. No Additional Compensation for Delays Within Developer's Control

16.3.1. Developer is aware that governmental agencies, including, without limitation, the Division of the State Architect, the Department of General Services, gas companies, electrical utility companies, water districts, and other agencies may have to approve Developer-prepared drawings or approve a proposed installation. Accordingly, Developer has included in the Guaranteed Project Cost, time for possible review of its drawings and for reasonable delays and damages that may be caused by such agencies. Thus, Developer is not entitled to make a claim for damages or delays arising from the review of Developer's drawings.

16.3.2. Developer shall only be entitled to compensation for delay when all of the following conditions are met:

16.3.2.1. The District or its consultants, employees, architects or contractors are responsible for the delay;

16.3.2.2. The delay was not reasonably anticipated by District and Developer; and

16.3.2.3. Developer complies with the claims procedure of the Contract Documents.

16.4. Float or Slack in the Schedule

Float or slack is the amount of time between the early start date and the late start date, or the early finish date and the late finish date, of any of the activities in the schedule. Float or slack is not for the exclusive use of or benefit of either the District or the Developer, however it shall be used as necessary to accommodate delays in the progress of the Work which may occur during the course of construction, as determined by the District. Developer shall not be entitled to an extension of time for any claimed delays to the extent that such delays may be covered by the float.

17. CHANGES IN THE WORK

17.1. No Changes Without Authorization

17.1.1. There shall be no change whatsoever in the Drawings, Specifications, or in the Work without an executed Change Order authorized by the District as herein provided. District shall not be liable for the cost of any extra work or any substitutions, changes, additions, omissions, or deviations from the Drawings and Specifications unless the District's governing board has authorized the same and the cost thereof has been approved in writing by Change Order. No extension of time for performance of the Work shall be allowed hereunder unless claim for such extension is made at the time changes in the Work are ordered, and such time duly adjusted in writing in the Change Order. The provisions of the Contract Documents shall apply to all such changes, additions, and omissions with the same effect as if originally embodied in the Drawings and Specifications.

17.1.2. Developer shall perform immediately all work that has been authorized by a fully executed Change Order. Developer shall be fully responsible for any and all delays and/or expenses caused by Developer's failure to expeditiously perform this Work.

17.1.3. Should any Change Order result in an increase in the Guaranteed Project Cost, the cost of that Change Order shall be agreed to, in writing, in advance by Developer and District. In the event that Developer proceeds with any change in Work without a Change Order executed by the District, Developer waives any claim of additional compensation or time for that additional work.

17.1.4. Developer understands, acknowledges, and agrees that the reason for District authorization is so that District may have an opportunity to analyze the Work and decide whether the District shall proceed with the Change Order or alter the Project so that a change in Work becomes unnecessary.

17.2. Architect Authority

The Architect will have authority to order minor changes in the Work not involving any adjustment in the Guaranteed Project Cost, or an extension of the Contract Time, or a change that is inconsistent with the intent of the Contract Documents. These changes shall be effected by written Change Order or by Architect's response(s) to RFI(s).

17.3. Change Orders

17.3.1. A Change Order is a written instrument prepared and issued by the District and/or the Architect and signed by the District (as authorized by the District's governing board), the Developer, the Architect, and approved by the Project Inspector (if necessary) and DSA (if necessary), stating their agreement regarding all of the following:

17.3.1.1. A description of a change in the Work;

17.3.1.2. The amount of the adjustment in the Guaranteed Project Cost, if any; and

17.3.1.3. The extent of the adjustment in the Contract Time, if any.

17.4. Price Request

17.4.1. Definition of Price Request

A Price Request ("PR") is a written request prepared by the District or the Architect requesting the Developer to submit to the District and/or the Architect an estimate of the effect of a proposed change in the Work on the Guaranteed Project Cost and the Contract Time.

17.4.2. Scope of Price Request

A Price Request shall contain adequate information, including any necessary Drawings and Specifications, to enable Developer to provide the cost breakdowns required herein. The Developer shall not be entitled to any additional compensation for preparing a response to a Price Request, whether ultimately accepted or not.

17.5. Proposed Change Order

17.5.1. Definition of Proposed Change Order

A Proposed Change Order ("PCO") is a written request prepared by the Developer requesting that the District and the Architect issue a Change Order based upon a proposed change to the Work.

17.5.2. Changes in Guaranteed Project Cost

A PCO shall include breakdowns pursuant to the revisions herein to validate any change in Guaranteed Project Cost.

17.5.3. Changes in Time

A PCO shall also include any changes in time required to complete the Project. Any additional time requested shall not be the number of days to make the proposed change, but must be based upon the impact to the Construction Schedule as defined in the Contract Documents. If Developer fails to request a time extension in a PCO, then the Developer is thereafter precluded from requesting time and/or claiming a delay.

17.5.4. Unknown and/or Unforeseen Conditions

If Developer submits a PCO requesting an increase in Guaranteed Project Cost and/or Contract Time that is based at least partially on Developer's assertion that Developer has encountered unknown and/or unforeseen condition(s) on the Project, then Developer shall base the PCO on provable information that demonstrates that the unknown and/or unforeseen condition(s) were actually or reasonably unknown and/or unforeseen. If not, the District shall deny the PCO and the Developer shall complete the Project without any increase in Guaranteed Project Cost and/or Contract Time based on that PCO.

17.6. Format for Proposed Change Order

17.6.1. The following format shall be used as applicable by the District and the Developer (e.g. Change Orders, PCO's) to communicate proposed additions and deductions to the Contract, supported by attached documentation.

	SUBCONTRACTOR PERFORMED WORK	ADD	DEDUCT
(a)	Material (attach itemized quantity and unit cost plus sales tax)		
(b)	Add Labor (attach itemized hours and rates, fully encumbered)		
(c)	Add Equipment (attach suppliers' invoice)		
(d)	SUBTOTAL		
(e)	Add Subcontractor's overhead and profit , not to exceed ten percent (10%) of item (d)		
(f)	SUBTOTAL		
(g)	Add Developer's fee, overhead, profit & general conditions , not to exceed five percent (5.0%) of the sum of item (d)		
(h)	SUBTOTAL		
(i)	Add Bond and Insurance , not to exceed one and one half percent (1.5%) of Item (h)		
(j)	TOTAL		
(k)	Time		_____ Days

	DEVELOPER PERFORMED WORK	ADD	DEDUCT
(a)	Material (attach itemized quantity and unit cost plus sales tax)		
(b)	Add Labor (attach itemized hours and rates, fully encumbered)		
(c)	Add Equipment (attach suppliers' invoice)		
(d)	SUBTOTAL		
(e)	Add Developer's fee, overhead, profit & general conditions , not to exceed fifteen percent (15.0%) of the sum of item (d)		
(f)	SUBTOTAL		
(i)	Add Bond and Insurance , not to exceed one and one half percent (1.5%) of item (f)		
(j)	TOTAL		
(k)	Time		_____ Days

17.7. Change Order Certification

17.7.1. All Change Orders and PCOs must include the following certification by the Developer:

The undersigned Developer approves the foregoing as to the changes, if any, and the Guaranteed Project Cost specified for each item and as to the extension of time allowed, if any, for Project Completion, and agrees to furnish all labor, materials, and service, and perform all work necessary to complete any additional work specified for the consideration stated herein. Submission of sums which have no basis in fact or which Developer knows are false are at the sole risk of Developer and may be a violation of the False Claims Act set forth under Government Code section 12650 et seq. It is understood that the changes herein to the Contract shall only be effective when approved by the governing board of the District.

It is expressly understood that the value of the extra Work or changes expressly includes any and all of the Developer's costs and expenses, both direct and indirect, resulting from additional time required on the Project or resulting from delay to the Project. Any costs, expenses, damages, or time extensions not included are deemed waived.

17.8. Determination of Change Order Cost

17.8.1. The amount of the increase or decrease in the Guaranteed Project Cost from a Change Order, if any, shall be determined in one or more of the following ways as applicable to a specific situation and at the District's discretion:

- 17.8.1.1.** District acceptance of a PCO;
- 17.8.1.2.** By amounts contained in Developer's schedule of values, if applicable;
- 17.8.1.3.** By agreement between District and Developer.

17.8.2. If the District has put in contingency(s) and/or allowance(s) in **Exhibit "C"** to the Facilities Lease, then approved Change Order(s) may be paid out of those contingency(s) and/or allowance(s), pursuant to **Exhibit "C"** and if agreed to by the District.

17.9. Deductive Change Orders

All deductive Change Order(s) must be prepared pursuant to the provisions herein. If Developer offers a proposed amount for a deductive Change Order(s), Developer shall include a minimum of five percent (5%) total overhead, profit & general conditions to be deducted with the amount of the work of the Change Order(s). If Subcontractor work is involved, Subcontractors shall also include a minimum of five percent (5%) total overhead, profit & general conditions to be deducted with the amount of its deducted work. Any deviation from this provision shall not be permitted without the District's prior written approval.

17.10. Construction Change Directives / Unilateral Change Orders

17.10.1. A Construction Change Directive (or Unilateral Change Order) is a written order prepared and issued by the District, the Construction Manager, and/or the Architect and signed by the District and the Architect, directing a change in the Work. The District may as provided by law, by Construction Change Directive and without invalidating the Contract, order changes in the Work consisting of additions, deletions, or other revisions. If all or a portion of the Project is being funded by funds requiring approval by the State Allocation Board (SAB), these revisions may be subject to compensation once approval of same is received and funded by the SAB, and funds are released by the Office of Public School Construction (OPSC). Any dispute as to the sum of the Construction Change Directive or timing of payment shall be resolved pursuant to the Payment and Claims and Disputes provisions herein.

17.10.2. The District may issue a Construction Change Directive in the absence of agreement on the terms of a Change Order.

17.11. Discounts, Rebates, and Refunds

For purposes of determining the cost, if any, of any change, addition, or omission to the Work hereunder, all trade discounts, rebates, refunds, and all returns from the sale of surplus materials and equipment shall accrue and be credited to the Developer, and the Developer shall make provisions so that such discounts, rebates, refunds, and returns may be secured, and the amount thereof shall be allowed as a reduction of the Developer's cost in determining the actual cost of construction for purposes of any change, addition, or omission in the Work as provided herein. Such discounts and rebates generated as a result of early payments shall only be credited to the District, provided that the District provides Developer with early payment in order to secure such discounts and rebates.

17.12. Accounting Records

With respect to portions of the Work performed by Change Orders, the Developer shall keep and maintain cost-accounting records satisfactory to the District, which shall be available to the District on the same terms as any other books and records the Developer is required to maintain under the Contract Documents.

17.13. Notice Required

If the Developer desires to make a claim for an increase in the Guaranteed Project Cost, or any extension in the Contract Time for Project Completion, it shall notify the District pursuant to the provisions herein. No claim shall be considered unless made in accordance with this subparagraph. Developer shall proceed to execute the Work even though the adjustment may not have been agreed upon. Any change in the Guaranteed Project Cost or extension of the Contract Time resulting from such claim shall be authorized by a Change Order.

17.14. Applicability to Subcontractors

Any requirements under this Article shall be equally applicable to Change Orders issued to Subcontractors by the Developer to the extent as required by the Contract Documents.

17.15. Alteration to Change Order Language

Developer shall not alter Change Orders or reserve time in Change Orders. Developer shall execute finalized Change Orders and proceed under the provisions herein with proper notice.

17.16. Failure of Developer to Execute Change Order

Developer shall be in default of the Contract if Developer fails to execute a Change Order when the Developer agrees with the addition and/or deletion of the Work in that Change Order.

17.17. Allowances

To the extent any item or portion of the Work is required by the Contract Documents to be priced as an Allowance, any amounts remaining in the Allowance which are to be deducted from the Guaranteed Project Cost shall be calculated according to the provisions of **Exhibit "C"** to the Facilities Lease and the Deductive Change Order provisions herein.

18. REQUESTS FOR INFORMATION

18.1. Any Request for Information ("RFI") shall reference all applicable Contract Document(s), including Specification section(s), detail(s), page number(s), drawing number(s), and sheet number(s), etc. The Developer shall make suggestions and interpretations of the issue raised by each Request for Information. A Request for Information cannot modify the Guaranteed Project Cost, Contract Time, or the Contract Documents.

18.2. The Developer shall be responsible for any costs incurred for professional services that District may deduct from any amounts owing to the Developer, if Developer makes multiple Requests for Information that request interpretation(s) or decision(s) of a matter where the information sought is equally available to the Developer. District, at its sole discretion, shall deduct from and/or invoice Developer for all the professional services arising herein.

18.3. Requests for Information shall comply with all requirements of the Contract Documents.

18.4. Prior to submitting the RFI, Developer shall diligently review the Contract Documents for information responsive to the RFI, including information incorporated by reference. Developer should not issue RFI's regarding information contained in or inferable from the Contract Documents, including information incorporated by reference. An RFI is invalid if the RFI response is contained in or inferable from the Contract Documents.

18.5. Developer shall be responsible for preparing and submitting RFI's so as to not cause delay to the progress of the Work nor to cause any impact to the Developer's labor productivity. An RFI may be considered untimely if not submitted within **Forty Eight (48) hours** of receipt from a Developer's subcontractor. Untimely submission of any RFI will preclude Developer from asserting any claims for delay or for labor impact against the District.

19. PAYMENTS

19.1. Guaranteed Project Cost

As compensation for Developer's construction of the Project, the District shall pay Developer pursuant to the terms of **Exhibit "C"** to the Facilities Lease.

19.2. Applications for Tenant Improvement Payments

19.2.1. Procedure for Applications for Tenant Improvement Payments

19.2.1.1. Not before the fifth (5th) day of each calendar month during the progress of the Work, Developer shall submit to the District and the Architect an itemized Application for Payment for operations completed in accordance with the Schedule of Values. Each Application for Tenant Improvement Payment shall be notarized, if required, and supported by the following or each portion thereof unless waived by the District in writing:

- 19.2.1.1.1.** The amount paid to the date of the Application for Tenant Improvement Payment to the Developer, to all its Subcontractors, and all others furnishing labor, material, or equipment for its Contract;
- 19.2.1.1.2.** The amount being requested under the Application for Tenant Improvement Payment by the Developer on its own behalf and separately stating the amount requested on behalf of each of the Subcontractors and all others furnishing labor, material, and equipment under the Contract;
- 19.2.1.1.3.** The balance that will be due to each of such entities after said payment is made;
- 19.2.1.1.4.** A certification that the As-Built Drawings and annotated Specifications are current;
- 19.2.1.1.5.** Itemized breakdown of work done for the purpose of requesting partial payment;
- 19.2.1.1.6.** An updated and acceptable construction schedule in conformance with the provisions herein;
- 19.2.1.1.7.** The additions to and subtractions from the Guaranteed Project Cost and Contract Time;
- 19.2.1.1.8.** Material invoices, evidence of equipment purchases, rentals, and other support and details of cost as the District may require from time to time;

- 19.2.1.1.9.** The percentage of completion of the Developer's Work by line item;
- 19.2.1.1.10.** Schedule of Values updated from the preceding Application for Tenant Improvement Payment;
- 19.2.1.1.11.** A duly completed and executed conditional waiver and release upon progress payment compliant with Civil Code section 8132 from each subcontractor of any tier and supplier to be paid from the current progress payment;
- 19.2.1.1.12.** A duly completed and executed unconditional waiver and release upon progress payment compliant with Civil Code section 8134 from each subcontractor of any tier and supplier that was paid from the progress payment from sixty (60) days prior; and
- 19.2.1.1.13.** A certification by the Developer of the following:

The Developer warrants title to all Work performed as of the date of this payment application. The Developer further warrants that all Work performed as of the date of this payment application is free and clear of liens, claims, security interests, or encumbrances in favor of the Developer, Subcontractors, material and equipment suppliers, workers, or other persons or entities making a claim by reason of having provided labor, materials, and equipment relating to the Work, except those of which the District has been informed.

- 19.2.1.1.14.** If the District has an LCP in force on this Project and if not previously submitted as required herein, all remaining certified payroll record ("CPR(s)") for each journeyman, apprentice, worker, or other employee employed by the Developer and/or each Subcontractor in connection with the Work for the period of the Application for Payment. As indicated herein, if the District has an LCP in force on this Project, the District shall not make any payment to Developer until:

- 19.2.1.1.14.1.** Developer and/or its Subcontractor(s) provide CPRs acceptable to the District, and

- 19.2.1.1.14.2.** The District is given sufficient time to review and/or audit the CPRs to determine their acceptability. Any delay in Developer and/or its Subcontractor(s) providing CPRs to the District in a timely manner will directly delay the District's review and/or audit of the CPRs and Developer's payment.

19.2.1. Prerequisites for Tenant Improvement Payments

19.2.1.1. First Payment Request: The following items, if applicable, must be completed before the District will accept and/or process the Developer's first payment request:

- 19.2.1.1.1.** Schedule of unit prices, if applicable;
- 19.2.1.1.2.** Receipt by Architect of all submittals due as of the date of the payment application;
- 19.2.1.1.3.** Copies of authorizations and licenses from governing authorities;
- 19.2.1.1.4.** Initial progress report;

19.2.1.1.5. Surveyor qualifications;

19.2.1.1.6. Written acceptance of District's survey of rough grading, if applicable;

19.2.1.1.7. List of all Subcontractors, with names, license numbers, telephone numbers, and Scope of Work;

19.2.1.1.8. All bonds and insurance endorsements; and

19.2.1.1.9. Resumes of Developer's project manager, and if applicable, job site secretary, record documents recorder, and job site superintendent.

19.2.1.2. No Waiver of Criteria. Any payments made to Developer where criteria set forth herein have not been met shall not constitute a waiver of said criteria by District. Instead, such payment shall be construed as a good faith effort by District to resolve differences so Developer may pay its Subcontractors and suppliers. Developer agrees that failure to submit such items may constitute a breach of contract by Developer and may subject Developer to termination.

19.3. District's Approval of Application for Tenant Improvement Payment

19.3.1. Upon receipt of an Application for Tenant Improvement Payment, The District shall act in accordance with both of the following:

19.3.1.1. Each Application for Tenant Improvement Payment shall be reviewed by the District as soon as practicable after receipt for the purpose of determining that the Application for Tenant Improvement Payment is a proper Application for Tenant Improvement Payment.

19.3.1.2. Any Application for Tenant Improvement Payment determined not to be a proper Application for Tenant Improvement Payment suitable for payment shall be returned to the Developer as soon as practicable, but not later than seven (7) days, after receipt. An Application for Tenant Improvement Payment returned pursuant to this paragraph shall be accompanied by a document setting forth in writing the reasons why the Application for Tenant Improvement Payment is not proper. The number of days available to the District to make a payment without incurring interest pursuant to this section shall be reduced by the number of days by which the District exceeds this seven-day return requirement.

19.3.1.3. An Application for Tenant Improvement Payment shall be considered properly executed if funds are available for payment of the Application for Tenant Improvement Payment, and payment is not delayed due to an audit inquiry by a financial officer or auditor of the District, the County, or the State.

19.3.2. The District's review of the Developer's Application for Tenant Improvement Payment will be based on the District's and the Architect's observations at the Site and the data comprising the Application for Tenant Improvement Payment that the Work has progressed to the point indicated and that, to the best of the District's and the Architect's knowledge, information, and belief, the quality of the Work is in accordance with the Contract Documents. The foregoing representations are subject to:

19.3.2.1. Observation of the Work for general conformance with the Contract Documents,

19.3.2.2. Results of subsequent tests and inspections,

19.3.2.3. Minor deviations from the Contract Documents correctable prior to Project Completion, and

19.3.2.4. Specific qualifications expressed by the Architect.

19.3.3. District's approval of the certified Application for Tenant Improvement Payment shall be based on Developer complying with all requirements for a fully complete and valid certified Application for Tenant Improvement Payment.

19.3.4. Payments to Developer

Within thirty (30) days after District approval of the Application for Tenant Improvement Payment, Developer shall be paid a sum equal to ninety percent (90%) of the value of the Work performed (as verified by Architect and Inspector and certified by Developer) up to the last day of the previous month, less the aggregate of previous payments and amount to be withheld as allowable herein. The value of the Work completed shall be Developer's best estimate. No inaccuracy or error in said estimate shall operate to release the Developer, or any Surety upon any bond, from damages arising from such Work, or from the District's right to enforce each and every provision of this Contract, and the District shall have the right subsequently to correct any error made in any estimate for payment.

19.3.5. No Waiver

No payment by District hereunder shall be interpreted so as to imply that District has inspected, approved, or accepted any part of the Work. Notwithstanding any payment, the District may enforce each and every provision of this Contract. The District may correct or require correction of any error subsequent to any payment.

19.3.6. Warranty of Title

19.3.6.1. If a lien or a claim based on a stop payment notice of any nature should at any time be filed against the Work or any District property, by any entity that has supplied material or services at the request of the Developer, Developer and Developer's Surety shall promptly, on demand by District and at Developer's and Surety's own expense, take any and all action necessary to cause any such lien or a claim based on a stop payment notice to be released or discharged immediately therefrom.

19.3.6.2. If the Developer fails to furnish to the District within ten (10) calendar days after demand by the District, satisfactory evidence that a lien or a claim based on a stop payment notice has been so released, discharged, or secured, the District may discharge such indebtedness and deduct the amount required therefor, together with any and all losses, costs, damages, and attorney's fees and expense incurred or suffered by District from any sum payable to Developer under the Contract.

19.3.7. Decisions to Withhold Payment

19.3.7.1. Reasons to Withhold Payment

The District may withhold payment to the extent reasonably necessary to protect the District if, in the District's opinion, the representations to the District required herein cannot be made. The District may withhold payment to such extent as may be necessary to protect the District from loss because of, but not limited to:

19.3.7.1.1. Defective Work not remedied within **FORTY-EIGHT (48)** hours of written notice to Developer;

- 19.3.7.1.2.** Stop payment notices or other liens served upon the District as a result of the Contract;
- 19.3.7.1.3.** Liquidated damages assessed against the Developer
- 19.3.7.1.4.** The cost of Project Completion if there exists reasonable doubt that the Work can be completed for the unpaid balance of the Guaranteed Project Cost or by the Contract Time;
- 19.3.7.1.5.** Damage to the District or other contractor(s);
- 19.3.7.1.6.** Unsatisfactory prosecution of the Work by the Developer:
- 19.3.7.1.7.** Failure to store and properly secure materials;
- 19.3.7.1.8.** Failure of the Developer to submit, on a timely basis, proper, sufficient, and acceptable documentation required by the Contract Documents, including, without limitation, a Construction Schedule, Schedule of Submittals, Schedule of Values, Monthly Progress Schedules, Shop Drawings, Product Data and samples, Proposed product lists, executed Change Orders, and/or verified reports;
- 19.3.7.1.9.** Failure of the Developer to submit As-Built Drawings;
- 19.3.7.1.10.** Erroneous estimates by the Developer of the value of the Work performed, or other false statements in an Application for Payment;
- 19.3.7.1.11.** Unauthorized deviations from the Contract Documents;
- 19.3.7.1.12.** Failure of the Developer to prosecute the Work in a timely manner in compliance with the milestones within the Construction Schedule, established progress schedules, and/or completion dates;
- 19.3.7.1.13.** If the District has an LCP in force on this Project, the failure to provide certified payroll records acceptable to the District for each journeyman, apprentice, worker, or other employee employed by the Developer and/or each Subcontractor in connection with the Work for the period of the Application for Payment;
- 19.3.7.1.14.** Failure to properly pay prevailing wages as defined in Labor Code section 1720 et seq., failure to comply with any other Labor Code requirements, and/or failure to comply with the District's LCP, if one is in force on this Project;
- 19.3.7.1.15.** Failure to properly maintain or clean up the Site;
- 19.3.7.1.16.** Payments to indemnify, defend, or hold harmless the District;
- 19.3.7.1.17.** Any payments due to the District, including but not limited to payments for failed tests, utilities changes, or permits;
- 19.3.7.1.18.** Failure to pay Subcontractor(s) or supplier(s) as required by law and by the Contract Documents;
- 19.3.7.1.19.** Developer is otherwise in breach, default, or in substantial violation of any provision of this Contract.

19.3.7.1.20. Extra services for Architect.

19.3.7.1.21. Extra services for the Inspector including but not limited to overtime tests and inspection or reinspection required due to Developer's failed tests or installation of unapproved or defective materials and Developer's requests for inspection and Developer's failure to attend the inspection.

19.3.7.1.22. Any other obligation(s) of the District which the District is authorized and/or compelled by law to perform.

19.3.7.2. Reallocation of Withheld Amounts. District may, in its reasonable discretion, apply any withheld amount to pay outstanding claims or obligations as defined herein. In so doing, District shall make such payments on behalf of Developer only after providing fourteen (14) days prior written notice to Developer, requesting the Developer provide information in response to same. District shall consider all information provided by Developer in exercising its discretion to pay any such claim or obligation. These payments may be made without prior judicial determination of claim or obligation. District will render Developer an accounting of funds disbursed on behalf of Developer.

19.3.7.3. If Developer defaults or neglects to carry out the Work in accordance with the Contract Documents or fails to perform any provision thereof, District may, after **FORTY-EIGHT (48)** hours written notice to the Developer and, without prejudice to any other remedy, make good such deficiencies. The District shall adjust the total Guaranteed Project Cost by reducing the amount thereof by the cost of making good such deficiencies. If District deems it inexpedient to correct Work that is damaged, defective, or not done in accordance with Contract provisions, an equitable reduction in the Guaranteed Project Cost (of at least one hundred twenty-five percent (125%) of the estimated reasonable value of the nonconforming Work) shall be made therefor.

19.3.8. Payment After Cure

When Developer removes the grounds for declining approval, payment shall be made for amounts withheld because of them. No interest shall be paid on any retention or amounts withheld due to the failure of the Developer to perform in accordance with the terms and conditions of the Contract Documents.

19.4. Subcontractor Payments

19.4.7. Payments to Subcontractors

No later than seven (7) days after receipt of each Tenant Improvement Payment, or pursuant to Business and Professions Code section 7108.5 and Public Contract Code section 7107, the Developer shall pay to each Subcontractor, out of the amount paid to the Developer on account of such Subcontractor's portion of the Work, the amount to which said Subcontractor is entitled. The Developer shall, by appropriate agreement with each Subcontractor, require each Subcontractor to make payments to its Sub-subcontractors in a similar manner.

19.4.8. No Obligation of District for Subcontractor Payment

The District shall have no obligation to pay, or to see to the payment of, money to a Subcontractor except as may otherwise be required by law.

19.4.9. Joint Checks

Provided Developer is in breach of its payment obligations to its subcontractors and after 14 days written notice, District shall have the right in its sole discretion, if necessary for the protection of the District, to issue joint checks made payable to the Developer and Subcontractors and material or equipment suppliers. The joint check payees shall be responsible for the allocation and disbursement of funds included as part of any such joint payment. In no event shall any joint check payment be construed to create any contract between the District and a Subcontractor of any tier, any obligation from the District to such Subcontractor, or rights in such Subcontractor against the District.

20. COMPLETION OF THE WORK

20.1. Completion

20.1.1. District will accept the Project and have the Notice of Completion recorded when Project Completion has been achieved in accordance with the Contract Documents and to the satisfaction of District.

20.1.2. The Project may only be accepted by action of the governing board of the District.

20.1.3. District, at its sole option, may accept the Project and have the Notice of Completion recorded when Project Completion has been completed to the satisfaction of District, except for minor corrective items, as distinguished from incomplete items. If Developer fails to complete all minor corrective items within thirty (30) days after the date of the District's acceptance of the Project, District shall withhold from the final payment one hundred fifty percent (150%) of an estimate of the amount sufficient to complete the corrective items, as determined by District, until the item(s) are completed.

20.1.4. At the end of the thirty-five (35) day period, if there are any items remaining to be corrected, District may elect to proceed as provided herein related to adjustments to Guaranteed Project Cost, and/or District's right to perform the Work of the Developer.

20.2. Closeout Procedures

20.2.1. In addition to the closeout procedures indicated herein, Developer shall comply with all the closeout requirements, procedures, and actions as indicated in all Contract Documents.

20.2.2. Punch List

The Developer shall notify the Architect when Developer considers the Work complete. Upon notification, Architect will prepare a list of minor items to be completed or corrected ("Punch List"). The Developer and/or its Subcontractors shall proceed promptly to complete and correct items on the Punch List. Failure to include an item on Punch List does not alter the responsibility of the Developer to complete all Work in accordance with the Contract Documents.

20.2.3. Closeout Requirements

20.2.3.1. Utility Connections

Buildings shall be connected to water, gas, sewer, and electric services, complete and ready for use. Service connections shall be made and existing services reconnected.

20.2.3.2. As-Built Drawings

20.2.3.2.1. Developer shall provide exact "as-built" of the Work upon Project Completion as indicated in the Contract Documents ("As-Built Drawings").

20.2.3.2.2. Developer is liable and responsible for any and all inaccuracies in As-Built Drawings, even if inaccuracies become evident at a future date.

20.2.3.2.3. Upon Project Completion and as a condition precedent to approval of final payment, Developer shall obtain the Inspector's approval of the corrected prints and provide to the District the As-Built Drawings and information on disk. When completed, Developer shall deliver corrected sepias and diskette/CD/other data storage device acceptable to District with AutoCAD file to the District.

20.2.3.3. Maintenance Manuals: Developer shall prepare all operation and maintenance manuals and date as indicated in the Contract Documents.

20.2.3.4. Closeout Documentation: Developer shall provide all Closeout Documentation, which shall include the following, without limitation:

20.2.3.4.1. A full set of As-Built, as further indicated herein

20.2.3.4.2. All Maintenance Manuals, operations manual(s), and related information, as further indicated herein

20.2.3.4.3. All Warranties, as further indicated herein

20.2.3.4.4. Verified report(s) for all scope(s) of work (DSA-6 Verified Report, Rev 04/08, or more recent revision if available)

20.3. Final Inspection

20.3.1. Developer shall comply with Punch List procedures as provided herein and in all the Contract Documents, and maintain the presence of its District-approved project superintendent and project manager until the Punch List is complete to ensure proper and timely completion of the Punch List. Under no circumstances shall Developer demobilize its forces prior to completion of the Punch List. Upon receipt of Developer's written notice that all of the Punch List items have been fully completed and the Work is ready for final inspection and acceptance, Architect and Project Inspector will inspect the Work and shall submit to Developer and District a final inspection report noting the Work, if any, required in order to complete in accordance with the Contract Documents. Absent unusual circumstances, this report shall consist of the Punch List items not yet satisfactorily completed.

20.3.2. Upon Developer's completion of all items on the Punch List and any other uncompleted portions of the Work, the Developer shall notify the District and Architect, who shall again inspect such Work. If the Architect finds the Work complete and acceptable under the Contract Documents, the Architect will notify Developer, who shall then jointly submit to the Architect and the District its final Application for Payment.

20.3.3. Final Inspection Requirements

20.3.3.1. Before calling for final inspection, Developer shall determine that the following have been performed:

20.3.3.1.1. The Work has been completed.

20.3.3.1.2. All life safety items are completed and in working order.

20.3.3.1.3. Mechanical and electrical Work are complete and tested, fixtures are in place, connected, and ready for tryout.

- 20.3.3.1.4. Electrical circuits scheduled in panels and disconnect switches labeled.
- 20.3.3.1.5. Painting and special finishes complete.
- 20.3.3.1.6. Doors complete with hardware, cleaned of protective film, relieved of sticking or binding, and in working order.
- 20.3.3.1.7. Tops and bottoms of doors sealed.
- 20.3.3.1.8. Floors waxed and polished as specified.
- 20.3.3.1.9. Broken glass replaced and glass cleaned.
- 20.3.3.1.10. Grounds cleared of Developer's equipment, raked clean of debris, and trash removed from Site.
- 20.3.3.1.11. Work cleaned, free of stains, scratches, and other foreign matter, of damaged and broken material replaced.
- 20.3.3.1.12. Finished and decorative work shall have marks, dirt, and superfluous labels removed.
- 20.3.3.1.13. Final cleanup, as provided herein.

20.4. Costs of Multiple Inspections

More than two (2) requests of the District to make a final inspection shall be considered an additional service of District, Architect, Construction Manager, and/or Project Inspector, and all subsequent costs will be invoiced to Developer and if funds are available, withheld from remaining payments.

20.5. Beneficial Occupancy or Use Prior to Project Completion

20.5.1. District's Rights to Beneficial Occupancy or Use

The District may, at its sole discretion, have Beneficial Occupancy or use of any completed or partially completed portion of the Project at any stage. Neither the District's Final Acceptance, the making of Final Payment, nor the Beneficial Occupancy or use of the Project, in whole or in part, by District shall constitute acceptance of the Project not in accordance with the Contract Documents nor relieve the Developer or the Developer's Performance Bond Surety from liability with respect to any warranties or responsibility for faulty or defective Work or materials, equipment and workmanship incorporated therein. The District and the Developer shall agree in writing to the responsibilities assigned to each of them for payments, security, maintenance, heat, utilities, damage to the Project, insurance, the period for correction of the Work, and the commencement of warranties required by the Contract Documents. Any dispute as to responsibilities shall be resolved pursuant to the Disputes and Claims provisions herein, with the added provision that during the dispute process, the District shall have the right to Beneficial Occupancy or use any portion of the Project that it needs or desires to use.

20.5.2. Inspection Prior to Beneficial Occupancy or Use

Immediately prior to partial Beneficial Occupancy or use of the Project, the District, the Developer, and the Architect shall jointly inspect the area to be occupied or portion of the Project to be used in order to determine and record the condition of the Work.

20.5.3. No Waiver

Unless otherwise agreed upon, partial or entire occupancy or use of a portion or portions of the Project shall not in of itself constitute or acceptance of the Project not complying with the requirements of the Contract Documents.

21. FINAL PAYMENT**21.1. Final Payment**

Upon receipt and approval of a valid and final Application for Tenant Improvement Payment, the Architect will issue a final Certificate of Tenant Improvement Payment. The District shall thereupon jointly inspect the Work and either accept the Project as complete or notify the Architect and the Developer in writing of reasons why the Project is not complete. Upon acceptance of the Project (absent unusual circumstances, will occur when the Punch List items have been satisfactorily completed), the District shall record a Notice of Completion with the County Recorder, and the Developer shall, upon receipt of final Tenant Improvement Payment from the District, pay the amount due Subcontractors. The amount of the final Tenant Improvement Payment shall be equal to the remaining ten percent (10%) of the value of the work performed, less the total amount to be paid as Lease Payments pursuant to Exhibit C.

21.2. Prerequisites for Final Tenant Improvement Payment The following conditions must be fulfilled prior to Final Tenant Improvement Payment:

21.2.1. A full and final waiver or release of all Stop payment notices in connection with the Work shall be submitted by Developer, including a release of Stop payment notice in recordable form, together with (to the extent permitted by law) a copy of the full and final release of all Stop payment notice rights.

21.2.2. A duly completed and executed conditional waiver and release upon final payment compliant with Civil Code section 8136 from each subcontractor of any tier and supplier to be paid from the current progress payment;

21.2.3. A duly completed and executed unconditional waiver and release upon progress payment compliant with Civil Code section 8138 from each subcontractor of any tier and supplier that was paid from the previous progress payment; and

21.2.4. The Developer shall have made all corrections to the Work that are required to remedy any defects therein, to obtain compliance with the Contract Documents or any requirements of applicable codes and ordinances, or to fulfill any of the orders or directions of District required under the Contract Documents.

21.2.5. Each Subcontractor shall have delivered to the Developer all written guarantees, warranties, applications, and bonds required by the Contract Documents for its portion of the Work.

21.2.6. Developer must have completed all requirements set forth under "Closeout Procedures," Including, without limitation, an approved set of complete As-Built Drawings.

21.2.7. Architect shall have issued its written approval that final payment can be made.

21.2.8. The Developer shall have delivered to the District all manuals and materials required by the Contract Documents.

21.2.9. The Developer shall have completed final clean up as provided herein.

21.2.10. After approval by the District of the Architect's Certificate of Payment,

21.2.11. After the satisfaction of the conditions set forth herein, and

21.2.12. After thirty-five (35) days following Project Completion.

21.2.13. No interest shall be paid on any amounts withheld due to a failure of the Developer to perform, in accordance with the terms and conditions of the Contract Documents.

22. UNCOVERING OF WORK

If a portion of the Work is covered without Inspector or Architect approval or not in compliance with the Contract Documents, it must, if required in writing by the District, the Project Inspector, or the Architect, be uncovered for the Project Inspector's or the Architect's observation and be replaced at the Developer's expense without change in the Guaranteed Project Cost or Contract Time.

23. NONCONFORMING WORK AND CORRECTION OF WORK

23.1. Nonconforming Work

23.1.1. Developer shall promptly remove from Premises all Work identified by District as failing to conform to the Contract Documents whether incorporated or not. Developer shall promptly replace and re-execute its own Work to comply with the Contract Documents without additional expense to the District and shall bear the expense of making good all work of other contractors destroyed or damaged by any removal or replacement pursuant hereto and/or any delays to the District or other contractors caused thereby.

23.1.2. If Developer does not remove or reasonably begin and diligently remove Work that District has identified as failing to conform to the Contract Documents within a reasonable time, not to exceed five (5) calendar days, District may remove it and may store any material at Developer's expense. If Developer does not pay expense(s) of that removal within ten (10) days' time thereafter, District may, upon ten (10) days' written notice, sell any material at auction or at private sale and shall deduct all costs and expenses incurred by the District and/or District may withhold those amounts from payment(s) to Developer.

23.2. Correction of Work

23.2.1. Correction of Rejected Work

Pursuant to the notice provisions herein, the Developer shall promptly correct the Work rejected by the District, the Architect, or the Project Inspector as failing to conform to the requirements of the Contract Documents, whether observed before or after Project Completion and whether or not fabricated, installed, or completed. The Developer shall bear costs of correcting the rejected Work, including additional testing, inspections, and compensation for the Inspector's or the Architect's services and expenses made necessary thereby.

23.2.2. One-Year Warranty Corrections

If, within one (1) year after the date of Project Completion or a designated portion thereof, or after the date for commencement of warranties established hereunder, or by the terms of an applicable special warranty required by the Contract Documents, any of the Work is found to be not in accordance with the requirements of the Contract Documents, the Developer shall correct it promptly after receipt of written notice from the District to do so. This period of one (1) year shall be extended with respect to portions of the Work first performed after Project Completion by the period

of time between Project Completion and the actual performance of the Work. This obligation hereunder shall survive acceptance of the Work under the Contract and termination of the Contract. The District shall give such notice promptly after discovery of the condition.

23.3. District's Right to Perform Work

23.3.1. If the Developer should neglect to prosecute or reasonably begin and diligently prosecute the Work properly or fail to perform any provisions of this contract, the District, after **five (5) calendar days** written notice to the Developer, may, without prejudice to any other remedy it may have, make good such deficiencies and may deduct the cost thereof from the payment then or thereafter due the Developer.

23.3.2. If it is found at any time, before or after Project Completion, that Developer has varied from the Drawings and/or Specifications, including, but not limited to, variation in material, quality, form, or finish, or in the amount or value of the materials and labor used, District may require at its option:

23.3.2.1. That all such improper Work be removed, remade or replaced, and all work disturbed by these changes be made good by Developer at no additional cost to the District;

23.3.2.2. That the District deduct from any amount due Developer the sum of money equivalent to the difference in value between the work performed and that called for by the Drawings and Specifications; or

23.3.2.3. That the District exercise any other remedy it may have at law or under the Contract Documents, including but not limited to the District hiring its own forces or another contractor to replace the Developer's nonconforming Work, in which case the District shall either issue a deductive Change Order or invoice the Developer for the cost of that work. Developer shall pay any invoices within thirty (30) days of receipt of same or District may withhold those amounts from payment(s) to Developer.

24. TERMINATION AND SUSPENSION AND SCOPE REDUCTION

The Parties' rights to terminate the Project are as indicated in the Facilities Lease. In the event of a termination of the Facilities Lease and notwithstanding any other provision in the Contract Documents, the Surety shall remain liable to all obligees under the Payment Bond and to the District under the Performance Bond for any claim related to the Project.

24.1. Emergency Termination of Public Contracts Act of 1949

24.1.1. In addition to the Parties' right to termination under the Facilities Lease, this Contract is subject to termination as provided by sections 4410 and 4411 of the Government Code of the State of California, being a portion of the Emergency Termination of Public Contracts Act of 1949.

24.1.1.1. Section 4410 of the Government Code states:

In the event a national emergency occurs, and public work, being performed by contract, is stopped, directly or indirectly, because of the freezing or diversion of materials, equipment or labor, as the result of an order or a proclamation of the President of the United States, or of an order of any federal authority, and the circumstances or conditions are such that it is impracticable within a reasonable time to proceed with a substantial portion of the work, then the public agency and the contractor may, by written agreement, terminate said contract.

24.1.1.2. Section 4411 of the Government Code states:

Such an agreement shall include the terms and conditions of the termination of the contract and provision for the payment of compensation or money, if any, which either party shall pay to the other or any other person, under the facts and circumstances in the case.

24.1.1.3. Compensation to the Developer shall be determined on the basis of the reasonable value of the Work done, including preparatory work. As an exception to the foregoing and at the District's discretion, in the case of any fully completed separate item or portion of the Work for which there is a separate previously submitted unit price or item on the accepted schedule of values, that price shall control. The District, at its sole discretion, may adopt the Guaranteed Project Cost as the reasonable value of the work done or any portion thereof.

24.2. Suspension of Work.

24.2.1. In the event that sufficient funds are not appropriated to complete the Project or the District determines that sufficient funds are not available to complete the Project, District may terminate or suspend the completion of the Project at any time by giving written notice to the Developer.

24.2.2. In the event that the District exercises this option, the District shall pay for any and all Work and materials completed or delivered onto the Site for which value is received, and the value of any and all Work then in progress and orders actually placed which cannot be canceled up to the date of notice of termination. The value of work and materials paid for shall include a factor of ten percent (10%) for the Developer's overhead and profit and there shall be no other costs or expenses paid to Developer. All work, materials and orders paid for pursuant to this provision shall become the property of the District.

24.2.3. District may, without cause, order Developer in writing to suspend, delay or interrupt the Project in whole or in part for such period of time as District may determine. When the District resumes the Project, the parties will attempt to negotiate an adjustment in the GPC for increases or decreases in the cost of performance of the Project caused by suspense, delay or interruption. If the parties cannot agree on an adjusted GPC, the District may terminate the leases as permitted herein.

24.3. Scope Reduction.

In cases of suspension, partial or complete termination, or at the discretion of the District, the District reserves the right to unilaterally approve a deductive Change Order to reduce scope of work or perform work with other forces or its own forces.

25. DISPUTES AND CLAIMS

25.1. Performance During Dispute And Claim Resolution Process. The Developer shall diligently proceed with Work on the Project at the same time that Disputes and Claims are addressed under this Article. It is the intent of District to resolve Disputes with the Developer as close to the events giving rise to the Disputes as possible, and to avoid stale or late Claims and the late documenting of Claims. Developer's failure to diligently proceed in accordance with the District's instructions will be considered a material breach of this Agreement.

25.2. Waiver. If Developer fails to timely submit the written notices required by the provisions in this Disputes and Claims section, Developer hereby waives and releases its rights regarding further review of its Dispute or Claim, unless Developer and District mutually agree in writing to other time limits.

25.3. Intention. The Dispute and Claims Resolution Process required herein are intended to provide a concise mechanism for resolving Disputes as they arise during the Project, while requiring accurate documentation related to contested issues as to those Disputes that are not contemporaneously resolved.

25.4. Exclusive Remedy. Compliance with the notice and claim submission procedures described in this Disputes and Claims section is an express condition precedent to the right to commence litigation, file a claim under the California Government Code, or commence any other legal action. The Developer cannot bring assert or bring any Claim in any Government Code claim or subsequent legal action until that Claim has gone through the Dispute and Claims Resolution Process . The District hereby exercises the power conferred upon it by Government Code Sections 930.2 and 930.4 to augment claims presentation procedures and create its own Dispute and Claims Resolution Process as an exclusive remedy as indicated in this Disputes and Claims section.

25.5. Other Provisions. If portions of the Contract, other than this Disputes and Claims section establish a specific process regarding a specific subject, then that process shall govern and control the resolutions of any disagreements thereunder. Otherwise, the provisions in this Disputes and Claims section shall control the resolution of all Disputes and Claims.

25.6. Subcontractors. Developer is responsible for providing this Disputes and Claims section to its Subcontractors and for ensuring that all Subcontractors or others who may assert Claims by and through Subcontractors and/or the Developer are informed of the Dispute and Claims resolution process in this Disputes and Claims section. No Claim submitted by any party that fails to follow the provisions of this Disputes and Claims section will be considered. Developer shall indemnify, keep and hold harmless the District and its consultants, against all suits, claims, damages, losses, and expenses, including but not limited to attorney's fees, caused by, arising out of, resulting from, or incidental to, the failure to provide this Disputes and Claims section to its Subcontractors or others who may assert Claims by and through Subcontractors and/or the Developer.

25.7. Dispute And Claim Resolution Process

25.7.1. Dispute: A Dispute is a request, demand or assertion by Developer or by Subcontractor(s) or others who make a demand or request by and through a Subcontractor or Developer during performance of the Work regarding money and/or time adjustments with which the District does not agree.

25.7.2. Claim: A Claim is a Dispute that remains unresolved after conclusion of the Dispute Resolution Process identified below. Individual unresolved Disputes may be aggregated into one or more Claim(s).

25.7.3. Dispute Resolution Process (Not for Claims)

25.7.3.1. Identifying, Presenting and Documenting a Dispute

25.7.3.1.1. Every Dispute shall be stated with specificity in writing and signed by Developer under penalty of perjury and presented to the District within thirty (30) calendar days of the incidents giving rise to the Dispute. The writing shall:

25.7.3.1.1.1. Identify all of the issues, events, conditions, circumstances and/or causes giving rise to the Dispute;

25.7.3.1.1.2. Identify all pertinent dates and/or durations and all actual and/or anticipated effects on the Contract Price, milestones and/or Contract Time adjustments; and

25.7.3.1.1.3. Identify in detail line-item costs if the Dispute seeks money.

25.7.3.1.2. The writing shall be accompanied by all documents substantiating Developer's position regarding the Dispute. A Dispute that asserts an effect on any schedule milestones and/or Contract Time shall include all pertinent scheduling data demonstrating the impact(s) on the critical path(s), milestone(s) and/or Contract Time.

25.7.3.1.3. Architect's Initial Decision. The District's Architect shall issue a written decision regarding the Dispute to the Developer within ten (10) calendar days of receipt of the written Dispute from the Developer.

25.7.3.2. Meet and Confer

25.7.3.2.1. Where There Is No Agreement: If there is no agreement between Developer and the Architect on a Developer's Dispute, including cases where a Developer's Proposed Change Order ("PCO") seeks money, time, and/or any other relief, then within ten (10) calendar days of the date of the District's written decision in response to Developer's Dispute or request for Proposed Change Order, Developer shall give written notice of its demand for a meet and confer meeting with District staff. A meet and confer meeting with District staff shall be a condition precedent to Developer seeking any further relief, including a demand for review as indicated below, in connection with the District's rejection .

25.7.3.2.2. Where There Is Partial Agreement: If Developer and the Architect partially agree on a Developer's Dispute but do not reach complete agreement, then the Architect shall issue a written decision or prepare a Change Order, if applicable, for the issues and/or amounts agreed to. For those issues not agreed to, Developer shall give written notice of its demand for a meet and confer meeting with District staff. A meet and confer meeting with District staff shall be a condition precedent to Developer seeking any further relief, including a demand for review as indicated below, in connection with the District's rejection.

25.7.3.2.3. District and Developer shall schedule the meet and confer meeting as soon as reasonably possible after Developer's written notice of its demand for a meet and confer meeting.

25.7.3.3. Developer's Demand for Review of Dispute

25.7.3.3.1. Developer shall give in writing a demand for review to the Construction Manager with copy to the Architect, within ten (10) calendar days of the meet and confer meeting. The written demand for review shall include copies of all documentation the Developer intends to rely upon in substantiating Developer's position regarding the Dispute, including any supplementary documentation the Developer deems appropriate for the District's consideration.

25.7.3.3.1.1. Construction Manager's Written Decision. The Construction Manager will review the Dispute and issue a written decision to Developer and Architect within thirty (30) calendar days from the date the demand for review and supporting documentation are received. The Construction Manager has the option to meet with Developer, or with Developer and any other party, before issuing a decision.

25.7.3.3.1.2. If no decision is issued within thirty (30) days after the demand for review, the District will be deemed to have rejected Developer's Dispute in its entirety, and Developer shall proceed with the Claim Resolution Process below.

25.7.3.3.1.3. If the Construction Manager's decision completely resolves the Dispute, the District will prepare and process a Change Order, if applicable, or proceed accordingly.

25.7.3.3.1.4. If the Construction Manager rejects the Dispute in whole or in part or does not issue a timely written response, and if Developer ever intends to seek relief regarding the unresolved issues of the Dispute, then Developer shall proceed with the Claim Resolution Process below.

25.7.3.3.1.5. Developer's costs incurred in seeking relief under this Disputes and Claims section are not recoverable from District.

25.7.4. Claim Resolution Process.

25.7.4.1. If a Dispute has not been resolved during the Dispute Resolution Process, the Developer shall submit within thirty (30) days a Claim along with the required detailed documentation for the District's consideration.

25.7.4.2. The Developer shall furnish three (3) certified copies of the required Claim documentation. The Claim documentation shall be complete when furnished. The evaluation of the Developer's Claim will be based upon District records and the Claim documents furnished by the Developer.

25.7.4.3. Claim documentation shall conform to generally accepted accounting principles and shall be in the following format:

25.7.4.3.1. General Introduction

25.7.4.3.2. General Background Discussion

25.7.4.3.3. Index of Issues (listed numerically)

25.7.4.3.4. For each issue, provide the following information and begin each issue on a new page:

25.7.4.3.4.1. Background

25.7.4.3.4.2. Chronology

25.7.4.3.4.3. Developer's position including all reason(s) for District's potential liability

25.7.4.3.4.4. Supporting documentation of merit or entitlement

25.7.4.3.4.5. Supporting documentation of damages

25.7.4.3.5. All critical path method schedules, both as-planned, monthly updates, schedule revisions, and as-build along with the computer disks of all schedules related to the Claim.

25.7.4.3.6. Productivity exhibits (if appropriate)

25.7.4.3.7. Summary of Damages for each issue

25.7.4.4. Supporting documentation of merit for each issue shall be cited by reference, photocopies, or explanation. Supporting documentation may include, but shall not be limited to the Contract Documents; correspondence; conference notes; shop drawings and submittals; shop drawing logs; survey books; inspection reports; delivery schedules; test reports; daily reports; subcontracts; fragmentary CPM schedules or time impact analyses; photographs; technical reports; requests for information; field instructions; and all other related records necessary to support the Developer's Claim.

25.7.4.5. Supporting documentation of damages for each issue shall be cited, photocopied, or explained. Supporting documentation may include, but shall not be limited to, any or all documents related to the preparation and submission of the proposal; certified, detailed labor records, including labor distribution reports; material and equipment procurement records; construction equipment ownership costs records or rental records; job cost reports; Subcontractor or vendor files and cost records; service cost records; purchase orders; invoices; Project as-planned and as-built cost records; general ledger records; variance reports; accounting adjustment records; and any other accounting materials necessary to support the Developer's Claim.

25.7.4.6. Developer shall include in its Claim documents all issue items and information that Developer contends are part of its Claim. Issues not included in the Claim documents shall not be considered.

25.7.4.7. Each copy of the Claim documentation shall be certified by a responsible officer of the Developer in accordance with the requirements of the Contract Documents.

25.7.4.8. The District may withhold from a progress payment and/or the final payment an amount not to exceed 150 percent of the disputed amount. The District may, but is not obligated to, notify the Surety and request the Surety's assistance in resolving the controversy.

25.7.4.9. District's Written Decision. The District Representative will render a written decision to the Developer relative to the Claim. The District's written decision shall be final and binding on the party(ies) but subject to mediation.

25.7.4.10. Mediation. Within thirty (30) days after the District renders its written decision, the Developer may request that the parties submit the Dispute to mediation. Absent a request for mediation, the District's written decision is final and binding on the parties.

25.7.4.11. Litigation. If, after a mediation as indicated above, the parties have not resolved the Dispute, the receiving party's decision made pursuant to mediation will be conclusive and binding regarding the Dispute unless the submitting party commences an action in a court of competent jurisdiction to contest such decision within ninety (90) days following the conclusion of such mediation or one (1) year following the accrual of the cause of action, whichever is later.

25.7.5. The District shall be entitled to remedy any false claims, as defined in California Government Code section 12650 *et seq.*, made to the District by the Developer or any Subcontractor under the standards set forth in Government Code section 12650 *et seq.* Any Developer or Subcontractor who submits a false claim shall be liable to the District for three times the amount of damages that the District sustains because of the false claim. A Developer or Subcontractor who submits a false claim shall also be liable to the District for (a) the costs, including attorney fees, of a civil action brought to recover any of those penalties or damages, and (b) a civil penalty of up to \$10,000 for each false claim.

25.8. Documentation of Resolution. If a Claim is resolved, the District shall determine if that resolution shall be documented in an Agreement and Release of Any and All Claims form or other document, as appropriate.

25.9. Dispute and Claim Resolution Process – Non-Applicability. The procedures and provisions in this Disputes and Claims section shall not apply to:

25.9.1. District's determination of what Work is or will be constructed, or whether the Work complies with the Contract Documents for purposes of accepting the Work;

25.9.2. District's rights and obligations as a public entity, such as, but without limitation, the revocation of pre-qualified or qualified status, barring a contractor from District contracts, the imposition of penalties or forfeitures prescribed by statute or regulation; provided, however, that penalties imposed against a public entity by statutes such as Section 7107, shall be subject to the mandatory dispute resolution provisions of this Disputes and Claims section and the Contract;

25.9.3. Personal injury, wrongful death or property damage claims;

25.9.4. Latent defect or breach of warranty or guarantee to repair;

25.9.5. Stop notices or stop payment notices;

25.9.6. Any other District rights as set forth herein;

25.9.7. Disputes arising out of or pertaining to an LCP (if applicable);

26. LABOR, WAGE & HOUR, APPRENTICE AND RELATED PROVISIONS

26.1. Labor Compliance Program

If the District, the District's designee and/or the California Department of Industrial Relations is operating a labor compliance program ("LCP") on this Project, Developer specifically acknowledges and understands that it shall perform the Work of this Agreement while complying with all the applicable provisions of the LCP, including, without limitation, the requirement that the Developer and all of its Subcontractors shall timely submit complete and accurate certified payroll records with each application for payment, or the District cannot issue payment. The following provisions indicated herein are specifically understood to be part of the LCP. If there is no LCP on this Project, the Developer and all of its subcontractor(s) are still required to comply with all applicable provisions of the Labor Code and the obligation to provide certified payroll records as indicated herein.

26.2. Wage Rates, Travel and Subsistence

26.2.1. Pursuant to the provisions of article 2 (commencing at section 1770), chapter 1, part 7, division 2, of the Labor Code of California, the general prevailing rate of per diem wages and the general prevailing rate for holiday and overtime work in the locality in which this public work is to be performed for each craft, classification, or type of worker needed to execute this Contract are on file at the District's principal office and copies will be made available to any interested party on request. Developer shall obtain and post a copy of these wage rates at the job site.

26.2.2. Holiday and overtime work, when permitted by law, shall be paid for at a rate of at least one and one-half times the above specified rate of per diem wages, unless otherwise specified. The holidays upon which those rates shall be paid need not be specified by the District, but shall be all holidays recognized in the applicable collective bargaining agreement. If the prevailing rate is not based on a collectively bargained rate, the holidays upon which the prevailing rate shall be paid shall be as provided in Section 6700 of the Government Code.

26.2.3. Developer shall pay and shall cause to be paid each worker engaged in Work on the Project not less than the general prevailing rate of per diem wages determined by the Director of the Department of Industrial Relations ("DIR") ("Director"), regardless of any contractual relationship which may be alleged to exist between Developer or any Subcontractor and such workers.

26.2.4. If during the period this bid is required to remain open, the Director determines that there has been a change in any prevailing rate of per diem wages in the locality in which the Work under the

Contract is to be performed, such change shall not alter the wage rates in the Notice to Bidders or the Contract subsequently awarded.

26.2.5. Pursuant to Labor Code section 1775, Developer shall, as a penalty to District, forfeit the statutory amount, (currently not to exceed two hundred dollars (\$200) for each calendar day, or portion thereof), for each worker paid less than the prevailing rates, as determined by the District and/or the Director, for the work or craft in which that worker is employed for any public work done under Contract by Developer or by any Subcontractor under it.

26.2.5.1. The amount of the penalty shall not be less than forty dollars (\$40) for each calendar day, or portion thereof, unless the failure of Developer was a good faith mistake and, if so, the error was promptly and voluntarily corrected when brought to the attention of Developer.

26.2.5.2. The amount of the penalty shall not be less than eighty dollars (\$80) for each calendar day or portion thereof, if Developer has been assessed penalties within the previous three (3) years for failing to meet Developer's prevailing wage obligations on a separate contract, unless those penalties were subsequently withdrawn or overturned.

26.2.5.3. The amount of the penalty may not be less than one hundred twenty dollars (\$120) for each calendar day, or portion thereof, if the Labor Commissioner determines the Developer willfully violated Labor Code section 1775.

26.2.5.4. The difference between such prevailing wage rates and the amount paid to each worker for each calendar day or portion thereof for which each worker was paid less than the prevailing wage rate, shall be paid to each worker by Developer.

26.2.6. Any worker employed to perform Work on the Project, which Work is not covered by any classification listed in the general prevailing wage rate of per diem wages determined by the Director, shall be paid not less than the minimum rate of wages specified therein for the classification which most nearly corresponds to Work to be performed by him, and such minimum wage rate shall be retroactive to time of initial employment of such person in such classification.

26.2.7. Pursuant to Labor Code section 1773.1, per diem wages are deemed to include employer payments for health and welfare, pension, vacation, travel time, subsistence pay, and apprenticeship or other training programs authorized by section 3093, and similar purposes.

26.2.8. Developer shall post at appropriate conspicuous points on the Site of Project, a schedule showing all determined minimum wage rates and all authorized deductions, if any, from unpaid wages actually earned. In addition, Developer shall post a sign-in log for all workers and visitors to the Site, a list of all subcontractors of any tier on the Site, and the required Equal Employment Opportunity poster(s).

26.3. Hours of Work

26.3.1. As provided in article 3 (commencing at section 1810), chapter 1, part 7, division 2, of the Labor Code, eight (8) hours of labor shall constitute a legal days work. The time of service of any worker employed at any time by Developer or by any Subcontractor on any subcontract under this Contract upon the Work or upon any part of the Work contemplated by this Contract shall be limited and restricted by Developer to eight (8) hours per day, and forty (40) hours during any one week, except as hereinafter provided. Notwithstanding the provisions hereinabove set forth, Work performed by employees of Developer in excess of eight (8) hours per day and forty (40) hours during any one week, shall be permitted upon this public work upon compensation for all hours worked in excess of eight (8) hours per day at not less than one and one-half times the basic rate of pay.

26.3.2. Developer shall keep and shall cause each Subcontractor to keep an accurate record showing the name of and actual hours worked each calendar day and each calendar week by each worker employed by Developer in connection with the Work or any part of the Work contemplated by this Contract. The record shall be kept open at all reasonable hours to the inspection of District and to the Division of Labor Standards Enforcement of the DIR.

26.3.3. Pursuant to Labor Code section 1813, Developer shall as a penalty to the District forfeit the statutory amount (believed by the District to be currently one hundred dollars (\$100)) for each worker employed in the execution of this Contract by Developer or by any Subcontractor for each calendar day during which such worker is required or permitted to work more than eight (8) hours in any one calendar day and forty (40) hours in any one calendar week in violation of the provisions of article 3 (commencing at section 1810), chapter 1, part 7, division 2, of the Labor Code.

26.3.4. Any Work necessary to be performed after regular working hours, or on Sundays or other holidays shall be performed without additional expense to the District.

26.4. Payroll Records

26.4.1. If the District, the District's designee and/or the California Department of Industrial Relations has an LCP in force on this Project then, pursuant to the provisions of section 1776 of the Labor Code, notice is hereby given that Developer shall prepare and provide to the District and/or the LCP and shall cause each Subcontractor performing any portion of the Work under this Contract to prepare and provide to the District and/or the LCP an accurate and certified payroll record ("CPR(s)"), showing the name, address, social security number, work classification, straight time, and overtime hours worked each day and week, and the actual per diem wages paid to each journeyman, apprentice, worker, or other employee employed by the Developer and/or each Subcontractor in connection with the Work.

26.4.1.1. In addition to any other requirements under Labor Code section 1770, et seq., the CPRs enumerated hereunder shall be certified and shall be provided to the District on a weekly basis. The CPRs from the Developer and each Subcontractor for each week shall be provided on or before Wednesday of the week following the week covered by the CPRs. District shall not make any payment to Developer until:

26.4.1.1.1. Developer and/or its Subcontractor(s) provide CPRs acceptable to the District, and

26.4.1.1.2. The District is given sufficient time to review and/or audit the CPRs to determine their acceptability. Any delay in Developer and/or its Subcontractor(s) providing CPRs to the District in a timely manner will directly delay the District's review and/or audit of the CPRs and Developer's payment.

26.4.2. Whether or not there is an LCP in force on this Project, all CPRs shall be available for inspection at all reasonable hours at the principal office of Developer on the following basis:

26.4.2.1. A certified copy of an employee's CPR shall be made available for inspection or furnished to the employee or his/her authorized representative on request.

26.4.2.2. CPRs shall be made available for inspection or furnished upon request to a representative of District, Division of Labor Standards Enforcement, Division of Apprenticeship Standards, and/or the Department of Industrial Relations.

26.4.2.3. CPRs shall be made available upon request by the public for inspection or copies thereof made; provided, however, that a request by the public shall be made through either the District, Division of Apprenticeship Standards, or the Division of Labor Standards Enforcement. If the

requested CPRs have not been provided pursuant to the provisions herein, the requesting party shall, prior to being provided the records reimburse the costs of preparation by Developer, Subcontractors, and the entity through which the request was made. The public shall not be given access to the records at the principal office of Developer.

26.4.3. The form of certification for the CPRs shall be as follows:

I, _____ (Name-Print), the undersigned, am the _____ (Position in business) with the authority to act for and on behalf of _____ (Name of business and/or Developer), certify under penalty of perjury that the records or copies thereof submitted and consisting of _____ (Description, number of pages) are the originals or true, full, and correct copies of the originals which depict the payroll record(s) of actual disbursements by way of cash, check, or whatever form to the individual or individual named, and (b) we have complied with the requirements of sections 1771, 1811, and 1815 for any work performed by our employees on the Project.

Date: _____ Signature: _____
(Section 16401 of the California Code of Regulations)

26.4.4. Each Developer shall file a certified copy of the CPRs with the entity that requested the records within ten (10) days after receipt of a written request.

26.4.5. Any copy of records made available for inspection as copies and furnished upon request to the public or any public agency by District, Division of Apprenticeship Standards, or Division of Labor Standards Enforcement shall be marked or obliterated in such a manner as to prevent disclosure of an individual's name, address, and social security number. The name and address of Developer awarded Contract or performing Contract shall not be marked or obliterated.

26.4.6. Developer shall inform District of the location of the records enumerated hereunder, including the street address, city, and county, and shall, within five (5) working days, provide a notice of change of location and address.

26.4.7. In the event of noncompliance with the requirements of this section, Developer shall have ten (10) days in which to comply subsequent to receipt of written notice specifying in what respects Developer must comply with this section. Should noncompliance still be evident after the ten (10) day period, Developer shall, as a penalty to District, forfeit one hundred dollars (\$100) for each calendar day, or portion thereof, for each worker, until strict compliance is effectuated. Upon the request of Division of Apprenticeship Standards or Division of Labor Standards Enforcement, these penalties shall be withheld from progress payments then due.

26.4.8. It shall be the responsibility of Developer to ensure compliance with the provisions of Labor Code section 1776.

26.5. Apprentices

26.5.1. Developer acknowledges and agrees that, if this Contract involves a dollar amount greater than or a number of working days greater than that specified in Labor Code section 1777.5, then this Contract is governed by the provisions of Labor Code Section 1777.5. It shall be the responsibility of Developer to ensure compliance with this Article and with Labor Code section 1777.5 for all apprenticeship occupations.

26.5.2. Apprentices of any crafts or trades may be employed and, when required by Labor Code section 1777.5, shall be employed provided they are properly registered in full compliance with the provisions of the Labor Code.

26.5.3. Every such apprentice shall be paid the standard wage paid to apprentices under the regulations of the craft or trade at which he/she is employed, and shall be employed only at the work of the craft or trade to which she/he is registered.

26.5.4. Only apprentices, as defined in section 3077 of the Labor Code, who are in training under apprenticeship standards and written apprentice agreements under chapter 4 (commencing at section 3070), division 3, of the Labor Code, are eligible to be employed. The employment and training of each apprentice shall be in accordance with the provisions of the apprenticeship standards and apprentice agreements under which he/she is training.

26.5.5. Pursuant to Labor Code section 1777.5, if that section applies to this Contract as indicated above, Developer and any Subcontractors employing workers in any apprenticeable craft or trade in performing any Work under this Contract shall apply to the applicable joint apprenticeship committee for a certificate approving the Developer or Subcontractor under the applicable apprenticeship standards and fixing the ratio of apprentices to journeymen employed in performing the Work.

26.5.6. Pursuant to Labor Code section 1777.5, if that section applies to this Contract as indicated above, Developer and any Subcontractor may be required to make contributions to the apprenticeship program.

26.5.7. If Developer or Subcontractor willfully fails to comply with Labor Code section 1777.5, then, upon a determination of noncompliance by the Administrator of Apprenticeship, it shall:

26.5.7.1. Be denied the right to bid on any subsequent project for one (1) year from the date of such determination;

26.5.7.2. Forfeit as a penalty to District the full amount as stated in Labor Code section 1777.7. Interpretation and enforcement of these provisions shall be in accordance with the rules and procedures of the California Apprenticeship Council and under the authority of the Chief of the Division of Apprenticeship Standards.

26.5.8. Developer and all Subcontractors shall comply with Labor Code section 1777.6, which section forbids certain discriminatory practices in the employment of apprentices.

26.5.9. Developer shall become fully acquainted with the law regarding apprentices prior to commencement of the Work. Special attention is directed to sections 1777.5, 1777.6, and 1777.7 of the Labor Code, and title 8, California Code of Regulations, section 200 et seq. Questions may be directed to the State Division of Apprenticeship Standards, 455 Golden Gate Avenue, San Francisco, California 94102.

26.5.10. Developer shall ensure compliance with all certification requirements for all workers on the Project including, without limitation, the requirements for electrician certification in Labor Code section 3099, et seq.

26.6. Non-Discrimination

26.6.1. Developer herein agrees not to discriminate in its recruiting, hiring, promotion, demotion, or termination practices on the basis of race, religious creed, national origin, ancestry, sex, age, or physical handicap in the performance of this Contract and to comply with the provisions of the California Fair Employment and Housing Act as set forth in part 2.8 of division 3 of the California Government Code, commencing at section 12900; the Federal Civil Rights Act of 1964, as set forth in Public Law 88-352, and

all amendments thereto; Executive Order 11246, and all administrative rules and regulations found to be applicable to Developer and Subcontractor.

26.6.2. Special requirements for Federally Assisted Construction Contracts: During the performance of this Contract, Developer agrees to incorporate in all subcontracts the provisions set forth in Chapter 60-1.4(b) of Title 41 published in Volume 33 No. 104 of the Federal Register dated May 28, 1968.

26.7. Labor First Aid

Developer shall maintain emergency first aid treatment for Developer's workers on the Project which complies with the Federal Occupational Safety and Health Act of 1970 (29 U.S.C. § 651 et seq.) and the California Occupational Safety and Health Act of 1973 (8 Cal. Code of Regs., §1 et seq.).

27. MISCELLANEOUS

27.1. Assignment of Antitrust Actions

Although this project may not have been formally bid, the following provisions may apply:

27.1.1. Section 7103.5(b) of the Public Contract Code states:

In entering into a public works contract or subcontract to supply goods, services, or materials pursuant to a public works contract, the Developer or subcontractor offers and agrees to assign to the awarding body all rights, title, and interest in and to all causes of action it may have under Section 4 of the Clayton Act (15 U.S.C. § 15) or under the Cartwright Act (Chapter 2 (commencing with Section 16700) of Part 2 of Division 7 of the Business and Professions Code), arising from purchases of goods, made and become effective at the time the awarding body tenders final payment to the Developer, without further acknowledgment by the Parties.

27.1.2. Section 4552 of the Government Code states:

In submitting a bid to a public purchasing body, the bidder offers and agrees that if the bid is accepted, it will assign to the purchasing body all rights, title, and interest in and to all causes of action it may have under Section 4 of the Clayton Act (15 U.S.C. § 15) or under the Cartwright Act (Chapter 2 (commencing with Section 16700) of Part 2 of Division 7 of the Business and Professions Code), arising from purchases of goods, materials, or services by the bidder for sale to the purchasing body pursuant to the bid. Such assignment shall be made and become effective at the time the purchasing body tenders final payment to the bidder.

27.1.3. Section 4553 of the Government Code states:

If an awarding body or public purchasing body receives, either through judgment or settlement, a monetary recovery for a cause of action assigned under this chapter, the assignor shall be entitled to receive reimbursement for actual legal costs incurred and may, upon demand, recover from the public body any portion of the recovery, including treble damages, attributable to overcharges that were paid by the assignor but were not paid by the public body as part of the bid price, less the expenses incurred in obtaining that portion of the recovery.

27.1.4. Section 4554 of the Government Code states:

Upon demand in writing by the assignor, the assignee shall, within one year from such demand, reassign the cause of action assigned under this part if the assignor has been or may have been

injured by the violation of law for which the cause of action arose and (a) the assignee has not been injured thereby, or (b) the assignee declines to file a court action for the cause of action.

27.1.5. Under this Article, “public purchasing body” is District and “bidder” is Developer.

27.2. Excise Taxes

If, under Federal Excise Tax Law, any transaction hereunder constitutes a sale on which a Federal Excise Tax is imposed and the sale is exempt from such Federal Excise Tax because it is a sale to a State or Local Government for its exclusive use, District, upon request, will execute documents necessary to show (1) that District is a political subdivision of the State for the purposes of such exemption, and (2) that the sale is for the exclusive use of District. No Federal Excise Tax for such materials shall be included in any Guaranteed Project Cost.

27.3. Taxes

Guaranteed Project Cost is to include any and all applicable sales taxes or other taxes that may be due in accordance with section 7051 of the Revenue and Taxation Code; Regulation 1521 of the State Board of Equalization or any other tax code that may be applicable.

27.4. Shipments

All shipments must be F.O.B. destination to Site or sites, as indicated in the Contract Documents. There must be no charge for containers, packing, unpacking, drayage, or insurance. The total Guaranteed Project Cost shall be all inclusive (including sales tax) and no additional costs of any type will be considered.

END OF DOCUMENT

EXHIBIT E

MEMORANDUM OF COMMENCEMENT DATE

[TO BE ENTERED INTO AFTER CONSTRUCTION IS COMPLETE TO COMMENCE THE LEASE TERM]

This MEMORANDUM OF COMMENCEMENT DATE is dated _____, 20____, and is made by and between _____ (“Developer”), as Lessor, and the **Mt. Diablo Unified School District** (“District”), as Lessee.

1. Developer and District have previously entered into a Facilities Lease dated as of _____, 20____, (the “Lease”) for the leasing by Developer to District of the Project Site and Project in _____, CA 9_____, referenced in the Lease.

2. District hereby confirms the following:

A. That all construction of the Project required to be performed pursuant to the Facilities Lease has been completed by Developer in all respects;

B. That District has accepted and entered into possession of the Project and now occupies same; and

C. That the term of the Facilities Lease commenced on _____, 20____, and will expire at 11:59 P.M. on _____, 20____.

THIS MEMORANDUM OF COMMENCEMENT DATE IS ACCEPTED AND AGREED on the date indicated below:

Dated: _____, 20____

Dated: _____, 20____

Mt. Diablo Unified School District

_____, **Inc.**

By: _____

By: _____

Print Name: _____

Print Name: _____

Print Title: _____ Superintendent _____

Print Title: _____

EXHIBIT F

CONSTRUCTION SCHEDULE

Attached is a detailed Project Construction Schedule with duration no longer than the Contract Time, and with specific milestones that Developer shall meet.

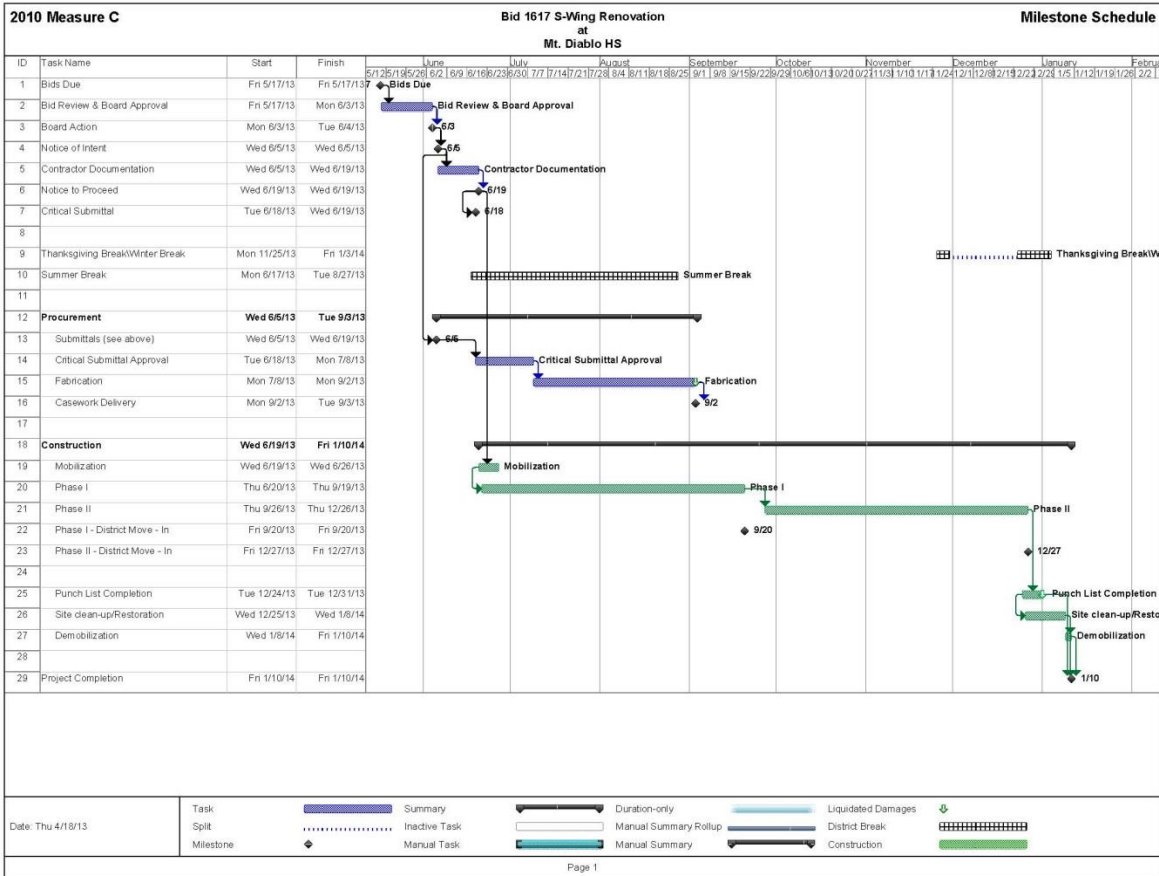

EXHIBIT G

SCHEDULE OF VALUES

Attached is a detailed Schedule of Values that complies with the requirements of the Construction Provisions (Exhibit D) and that has been approved by the District.

DRAFT

EXHIBIT H

AGREEMENT FOR PRELIMINARY
SERVICES

NOT USED

DRAFT

EXHIBIT I

CERTIFICATES AND BONDS TO LEASE-LEASEBACK DOCUMENTS
AND
DIVISION 1 DOCUMENTS TO LEASE-LEASEBACK DOCUMENTS

See Exhibit I

DRAFT

EXHIBIT J

PLANS, TECHNICAL SPECIFICATIONS, AND DRAWINGS

TECHNICAL SPECIFICATIONS

RFQ1615 Attachment C Technical Specs 03-15-13
(Verde Design, Inc. - Job Number 1208200-1209
99 Page(s))

DRAWINGS

RFQ1617 Attachment D Plans 02-19-13
(NLA - Job Number Y1211.00
53 Page(s))

DRAFT

EXHIBIT K

REVISIONS TO CONTRACT DOCUMENTS FOR

S-WING RENOVATION

FACILITIES LEASE

Section 3.4 (Operating School): The phasing plan shall be as indicated in Exhibit F.

Section 3.6 (No Work During Student Testing): The following dates and times apply to this section:

- Each January: Two (2) days (Finals)
- Each March: Two (2) days (CAHSEE)
- Each June: Two (2) days (Finals)
- Each April - May: Ten (10) days (STAR and AP)

EXHIBIT D TO FACILITIES LEASE

Section 6.2.1 [Staffing Requirement]: The minimum staffing for the Project shall be a competent:

- Project Manager,
- Construction Superintendent,
- Project Engineer, and
- Project Administrator

Developer shall provide with its proposal the name and resume for each specific individual that it is proposing for each position. Those persons shall be made available for interviews with the District, if requested

Section 7.3.1 [Minimum Subcontractor/Trade Contractor Bids]: The minimum number of bona fide bids from Subcontractors for a specific trade shall be as follows:

- For Subcontractors on scopes of Work with bids up to One Hundred Thousand Dollars (\$100,000):
 - **Three (3) Bids**
- For Subcontractors on scopes of Work with bids One Hundred Thousand One Dollars to Five Hundred Thousand Dollars (\$100,001 - \$500,000):
 - **Four (4) Bids**
- For Subcontractors on scopes of Work with bids from Five Hundred Thousand One Dollars (\$500,001) and above:
 - **Seven (7) Bids**

Section 15.1.1.4: The number of days that must be exceeded to claim extra time for “Adverse Weather”:

January	<u>6</u>	July	<u>0</u>
February	<u>5</u>	August	<u>0</u>
March	<u>4</u>	September	<u>1</u>
April	<u>3</u>	October	<u>2</u>
May	<u>1</u>	November	<u>4</u>
June	<u>0</u>	December	<u>5</u>

DIVISION 1 DOCUMENTS

DRAFT

RFQ/RFP 1617 - Attachment B

**Certificates and Bonds to
Lease-Leaseback Documents**

And

**Division 1 Documents to
Lease-Leaseback Documents**

**MOUNT DIABLO UNIFIED SCHOOL DISTRICT
SCIENCE CENTER REMODEL PROJECT**

**Mount Diablo Unified School District
and**

NONCOLLUSION AFFIDAVIT
Public Contract Code § 7106

TO BE EXECUTED BY DEVELOPER

STATE OF CALIFORNIA)
) ss.
COUNTY OF _____)

_____ being first duly sworn

deposes and says that he or she is _____

of _____,

the Developer making the foregoing Contract or previous proposals related to the Contract, that the Contract is not made in the interest of, or on behalf of, any undisclosed person, partnership, company, association, organization, or corporation; that the Contract is genuine and not collusive or sham; that the Developer has not directly or indirectly induced or solicited any other contractor to put in a false or sham proposal, and has not directly or indirectly colluded, conspired, connived, or agreed with any contractor or anyone else to put in a sham proposal, or that anyone shall refrain from proposing; that the Developer has not in any manner, directly or indirectly, sought by agreement, communication, or conference with anyone to fix its proposal or the Contract price of the Developer or any other contractor, or to fix any overhead, profit, or cost element of the proposal or the Contract price, or of that of any other contractor, or to secure any advantage against the District of anyone interested in the proposed Contract; that all statements contained in its proposal and Contract are true; and, further, that the Developer has not, directly or indirectly, submitted his or her proposal or the Contract price or any breakdown thereof, or the contents thereof, or divulged information or data relative thereto, or paid, and will not pay, any fee to any corporation, partnership, company association, organization, bid depository, or to any member or agent thereof to effectuate a collusive or sham proposal or Contract.

I certify and declare under penalty of perjury under the laws of the State of California that all the foregoing information in this Noncollusion Affidavit is true and correct.

Date: _____

Proper Name of Developer: _____

Signature: _____

Print Name: _____

Title: _____

(ATTACH NOTARIAL ACKNOWLEDGMENT FOR THE ABOVE SIGNATURE)

END OF DOCUMENT

WORKERS' COMPENSATION CERTIFICATION

Labor Code section 3700 in relevant part provides:

Every employer except the State shall secure the payment of compensation in one or more of the following ways:

- 1 By being insured against liability to pay compensation by one or more insurers duly authorized to write compensation insurance in this state.
- 2 By securing from the Director of Industrial Relations a certificate of consent to self-insure, which may be given upon furnishing proof satisfactory to the Director of Industrial Relations of ability to self-insure and to pay any compensation that may become due to its employees.

I am aware of the provisions of section 3700 of the Labor Code which require every employer to be insured against liability for workers' compensation or to undertake self-insurance in accordance with the provisions of that code, and I will comply with such provisions before commencing the performance of the Work of the Contract.

Date: _____

Proper Name of Developer: _____

Signature: _____

Print Name: _____

Title: _____

(In accordance with Article 5 - commencing at section 1860, chapter 1, part 7, division 2 of the Labor Code, the above certificate must be signed and filed with the awarding body prior to performing any Work under the Contract.)

END OF DOCUMENT

**PREVAILING WAGE AND
RELATED LABOR REQUIREMENTS CERTIFICATION**

I hereby certify that I will conform to the State of California Public Works Contract requirements regarding prevailing wages, benefits, on-site audits with 48-hours notice, payroll records, and apprentice and trainee employment requirements, for all Work on the Project including, without limitation, the labor compliance program, if in use on this Project.

Date: _____

Proper Name of Developer: _____

Signature: _____

Print Name: _____

Title: _____

END OF DOCUMENT

DISABLED VETERAN BUSINESS ENTERPRISE
PARTICIPATION CERTIFICATION

Section 17076.11 of the Education Code requires school districts using funds allocated pursuant to the State of California School Facility Program ("Program") for the construction and/or modernization of school buildings to have a participation goal for disabled veteran business enterprises ("DVBE") of at least three percent (3%), per year, of the overall dollar amount expended each year by the school district on projects that receive state funding.

1. **Disabled Veteran Business Enterprise.** A DVBE is a business enterprise certified by the California Office of Small Business as a DVBE.
2. **DVBE Participation Policy.** The District is committed to achieving this DVBE participation goal. The District encourages Developer to ensure maximum opportunities for the participation of DVBEs in the Work of the Contract.
3. **DVBE Participation Goal.** The three percent (3%) participation goal is not a quota, set-aside or rigid proportion.
4. **Certification of Participation.** At the time of execution of the Contract, the Developer will provide a statement to the District of anticipated participation of DVBEs in the contract.
5. **Submission of Report.** During performance of the Contract, Developer shall monitor the Work of the Contract, award of subcontracts and contracts for materials, equipment and supplies for the purpose of determining DVBE participation in the Work of the Contract.
 - a) Developer shall report on a monthly basis all DVBEs utilized in the performance of the Work, the type or classification of the Work performed by each DVBE, and the dollar value of the Work performed by each DVBE.
 - b) Upon completion of the Work of the Contract, Developer shall submit a report to the District in the form attached hereto identifying all DVBEs utilized in the performance of the Work, the type or classification of the Work performed by each DVBE, and the dollar value of the Work performed by each DVBE.
 - i) The submission to the District of this report is a condition precedent to the District's obligation to make payment of the Final Payment under the Contract Documents. The submission of this report shall be in addition to, and not in lieu of, any other conditions precedent set forth in the Contract Documents for the District's obligation to make payment of the Final Payment.
 - ii) The District reserves the right to request additional information or documentation from the Developer evidencing efforts to comply with the three percent (3%) DVBE participation goal.

DVBE PARTICIPATION REPORT

Developer Name: _____ Date: _____

Project Name: _____ Project Number: _____

DVBE Firm Name	Trade / Portion of Work	Subcontract/ Contract Value
Add more sheets as needed to include all information for each DVBE		

Does the cumulative dollar value of these DVBE contracts meet or exceed the participation goal of three percent (3%) of the final Contract Price, as adjusted by all change orders?

YES _____ NO _____

If your response is "NO", please attach to this report a detailed description of the reasons for your firm did not achieve the participation goal of three percent (3%) of the final Contract Price.

I certify and declare under penalty of perjury under the laws of the State of California that all the foregoing information is complete, true, and correct.

Date: _____

Proper Name of Developer: _____

Signature: _____

Print Name: _____

Title: _____

END OF DOCUMENT

DRUG-FREE WORKPLACE CERTIFICATION

This Drug-Free Workplace Certification form is required from the Developer pursuant to Government Code section 8350 et seq., the Drug-Free Workplace Act of 1990. The Drug-Free Workplace Act of 1990 requires that every person or organization awarded a contract or grant for the procurement of any property or service from any state agency must certify that it will provide a drug-free workplace by doing certain specified acts. In addition, the Act provides that each contract or grant awarded by a state agency may be subject to suspension of payments or termination of the contract or grant, and the contractor or grantee may be subject to debarment from future contracting, if the contracting agency determines that specified acts have occurred.

The District is not a "state agency" as defined in the applicable section(s) of the Government Code, but the District is a local agency and public school district under California law and requires all contractors on District projects to comply with the provisions and requirements of Government Code section 8350 et seq., the Drug-Free Workplace Act of 1990.

Developer shall certify that it will provide a drug-free workplace by doing all of the following:

- 1 Publishing a statement notifying employees that the unlawful manufacture, distribution, dispensation, possession, or use of a controlled substance is prohibited in the person's or organization's workplace and specifying actions which will be taken against employees for violations of the prohibition;
- 2 Establishing a drug-free awareness program to inform employees about all of the following:
 - a. The dangers of drug abuse in the workplace.
 - b. The person's or organization's policy of maintaining a drug-free workplace.
 - c. The availability of drug counseling, rehabilitation, and employee-assistance programs.
 - d. The penalties that may be imposed upon employees for drug abuse violations.
- 3 Requiring that each employee engaged in the performance of the contract or grant be given a copy of the statement required above, and that, as a condition of employment on the contract or grant, the employee agrees to abide by the terms of the statement.

I, the undersigned, agree to fulfill the terms and requirements of Government Code section 8355 listed above and will publish a statement notifying employees concerning (a) the prohibition of controlled substance at the workplace, (b) establishing a drug-free awareness program, and (c) requiring that each employee engaged in the performance of the contract be given a copy of the statement required by section 8355(a), and requiring that the employee agree to abide by the terms of that statement.

I also understand that if the District determines that I have either (a) made a false certification herein, or (b) violated this certification by failing to carry out the requirements of section 8355, that the Contract awarded herein is subject to termination, suspension of payments, or both. I further understand that, should I violate the terms of the Drug-Free Workplace Act of 1990, I may be subject to debarment in accordance with the requirements of section 8350 et seq.

I acknowledge that I am aware of the provisions of Government Code section 8350 et seq. and hereby certify that I will adhere to the requirements of the Drug-Free Workplace Act of 1990.

Date: _____

Proper Name of Developer: _____

Signature: _____

Print Name: _____

Title: _____

END OF DOCUMENT

TOBACCO-FREE ENVIRONMENT CERTIFICATION

Pursuant to, without limitation, 20 U.S.C section 6083, Labor Code section 6400 et seq., Health & Safety Code section 104350 et seq. and District Board Policies, all District sites, including the Project site, are tobacco-free environments. Smoking and the use of tobacco products by all persons is prohibited on or in District property. District property includes school buildings, school grounds, school owned vehicles and vehicles owned by others while on District property.

I acknowledge that I am aware of the District's policy regarding tobacco-free environments at District sites, including the Project site and hereby certify that I will adhere to the requirements of that policy and not permit any of my firm's employees, agents, subcontractors, or my firm's subcontractors' employees or agents to use tobacco and/or smoke on the Project site.

Date: _____

Proper Name of Developer: _____

Signature: _____

Print Name: _____

Title: _____

END OF DOCUMENT

HAZARDOUS MATERIALS CERTIFICATION

1. Developer hereby certifies that no Asbestos, or Asbestos-Containing Materials, polychlorinated biphenyl (PCB), or any material listed by the federal or state Environmental Protection Agency or federal or state health agencies as a hazardous material, or any other material defined as being hazardous under federal or state laws, rules, or regulations ("New Hazardous Material"), shall be furnished, installed, or incorporated in any way into the Project or in any tools, devices, clothing, or equipment used to affect any portion of Developer's work on the Project for District.
2. Developer further certifies that it has instructed its employees with respect to the above-mentioned standards, hazards, risks, and liabilities.
3. Asbestos and/or asbestos-containing material shall be defined as all items containing but not limited to chrysotile, crocidolite, amosite, anthophyllite, tremolite, and actinolite. Any or all material containing greater than one-tenth of one percent (.1%) asbestos shall be defined as asbestos-containing material.
4. Any disputes involving the question of whether or not material is New Hazardous Material shall be settled by electron microscopy or other appropriate and recognized testing procedure, at the District's determination. The costs of any such tests shall be paid by Developer if the material is found to be New Hazardous Material.
5. All Work or materials found to be New Hazardous Material or Work or material installed with equipment containing "New Hazardous Material" will be immediately rejected and this Work will be removed at Developer's expense at no additional cost to the District.
6. Developer has read and understood the document Hazardous Materials Procedures & Requirements, and shall comply with all the provisions outlined therein.

Date: _____

Proper Name of Developer: _____

Signature: _____

Print Name: _____

Title: _____

In addition to the requirement to provide this certification, Developer agrees that it shall provide all documentation requested by the District to confirm compliance with the requirements herein.

END OF DOCUMENT

LEAD-BASED MATERIALS CERTIFICATION

This certification provides notice to the Developer that:

- (1) The Developer's work may disturb lead-containing building materials.
- (2) The Developer must notify the District if any work may result in the disturbance of lead-containing building materials.

1. Lead as a Health Hazard

Lead poisoning is recognized as a serious environmental health hazard facing children today. Even at low levels of exposure, much lower than previously believed, lead can impair the development of a child's central nervous system, causing learning disabilities, and leading to serious behavioral problems. Lead enters the environment as tiny lead particles and lead dust disburse when paint chips, chalks, peels, wears away over time, or is otherwise disturbed. Ingestion of lead dust is the most common pathway of childhood poisoning; lead dust gets on a child's hands and toys and then into a child's mouth through common hand-to-mouth activity. Exposures may result from construction or remodeling activities that disturb lead paint, from ordinary wear and tear of windows and doors, or from friction on other surfaces.

Ordinary construction and renovation or repainting activities carried out without lead-safe work practices can disturb lead-based paint and create significant hazards. Improper removal practices, such as dry scraping, sanding, or water blasting painted surfaces, are likely to generate high volumes of lead dust.

Because the Developer and its employees will be providing services for the District, and because the Developer's work may disturb lead-containing building materials, CONTRACTOR IS HEREBY NOTIFIED of the potential presence of lead-containing materials located within certain buildings utilized by the District. All school buildings built prior to 1993 are presumed to contain some lead-based paint until sampling proves otherwise.

2. Overview of California Law

Education Code section 32240 et seq. is known as the Lead Safe Schools Protection Act. Under this act, the Department of Health Services ("DHS") is to conduct a sample survey of schools in the State of California for the purpose of developing risk factors to predict lead contamination in public schools. (Ed. Code, § 3224 1.)

Any school that undertakes any action to abate existing risk factors for lead is required to utilize trained and state-certified contractors, inspectors, and workers. (Ed. Code, § 32243, subd. (b).) Moreover, lead-based paint, lead plumbing, and solders, or other potential sources of lead contamination, shall not be utilized in the construction of any new school facility or the modernization or renovation of any existing school facility. (Ed. Code, § 32244.)

Both the Federal Occupational Safety and Health Administration ("Fed/OSHA") and the California Division of Occupational Safety and Health ("Cal/OSHA") have implemented safety orders applicable to all construction work where a contractor's employee may be occupationally exposed to lead.

The OSHA Regulations apply to all construction work where a contractor's employee may be occupationally exposed to lead. The OSHA Regulations contain specific and detailed requirements imposed on contractors subject to that regulation. The OSHA Regulations define construction work as work for construction, alteration, and/or repair, including painting and decorating. It includes, but is not limited to, the following:

- a. Demolition or salvage of structures where lead or materials containing lead are present;
- b. Removal or encapsulation of materials containing lead;
- c. New construction, alteration, repair, or renovation of structures, substrates, or portions thereof, that contain lead, or materials containing lead;

- d. Installation of products containing lead;
- e. Lead contamination/emergency cleanup;
- f. Transportation, disposal, storage, or containment of lead or materials containing lead on the site or location at which construction activities are performed; and
- g. Maintenance operations associated with the construction activities described in the subsection.

Because it is assumed by the District that all painted surfaces (interior as well as exterior) within the District contain some level of lead, it is imperative that the Developer, its workers and subcontractors fully and adequately comply with all applicable laws, rules and regulations governing lead-based materials (including title 8, California Code of Regulations, section 1532. 1).

The Developer must notify the District if any Work may result in the disturbance of lead-containing building materials. Any and all Work that may result in the disturbance of lead-containing building materials must be coordinated through the District. A signed copy of this Certification must be on file prior to beginning Work on the Project, along with all current insurance certificates.

3. Renovation, Repair and Painting Rule, Section 402(c)(3) of the Toxic Substances Control Act

In 2008, the U.S. Environmental Protection Agency, issued a rule pursuant to the authority of Section 402(c)(3) of the Toxic Substances Control Act, requiring lead safe work practices to reduce exposure to lead hazards created by renovation, repair and painting activities that disturb lead-based paint (Renovation, Repair and Painting Rule). Renovations in homes, childcare facilities, and schools built prior to 1978 must be conducted by certified renovations firms, using renovators with accredited training, and following the work practice requirements to reduce human exposures to lead.

Developer, its workers and subcontractors must fully and adequately comply with all applicable laws, rules and regulations governing lead-based materials, including those rules and regulations appearing within title 40 of the Code of Federal Regulations as part 745 (40 CFR 745).

The requirements apply to all contractors who disturb lead-based paint in a six-square-foot area or greater indoors or a 20-square-foot area outdoors. If a DPH-certified inspector or risk assessor determines that a home constructed before 1978 is lead-free, the federal certification is not required for anyone working on that particular building.

4. Developer's Liability

If the Developer fails to comply with any applicable laws, rules, or regulations, and that failure results in a site or worker contamination, the Developer will be held solely responsible for all costs involved in any required corrective actions, and shall defend, indemnify, and hold harmless the District, pursuant to the indemnification provisions of the Contract, for all damages and other claims arising therefrom.

If lead disturbance is anticipated in the Work, only persons with appropriate accreditation, registrations, licenses, and training shall conduct this Work.

It shall be the responsibility of the Developer to properly dispose of any and all waste products, including, but not limited to, paint chips, any collected residue, or any other visual material that may occur from the prepping of any painted surface. It will be the responsibility of the Developer to provide the proper disposal of any hazardous waste by a certified hazardous waste hauler. This company shall be registered with the Department of Transportation (DOT) and shall be able to issue a current manifest number upon transporting any hazardous material from any school site within the District.

The Developer shall provide the District with any sample results prior to beginning Work, during the Work, and after the completion of the Work. The District may request to examine, prior to the commencement of the Work, the lead training records of each employee of the Developer.

The Developer hereby acknowledges, under penalty of perjury, that it:

1. Has received notification of potential lead-based materials on the District's property;
2. Is knowledgeable regarding and will comply with all applicable laws, rules, and regulations governing work with, and disposal of, lead.

The undersigned warrants that he/she has the authority to sign on behalf of and bind the Developer. The District may require proof of such authority.

Date: _____

Proper Name of Developer: _____

Signature: _____

Print Name: _____

Title: _____

END OF DOCUMENT

IMPORTED MATERIALS CERTIFICATION

This form shall be executed by Developer and by all entities that, in any way, provide or deliver and/or supply any soils, aggregate, or related materials ("Fill") to the Project Site. All Fill shall satisfy the requirements of any environmental review of the Project performed pursuant to the statutes and guidelines of the California Environmental Quality Act, section 21000 et seq. of the Public Resources Code ("CEQA"), and the requirements of section 17210 et seq. of the Education Code, including requirements for a Phase I environmental assessment acceptable to the State of California Department of Education and Department of Toxic Substances Control.

To the furthest extent permitted by California law, the indemnification provisions in the Contract Documents apply to, without limitation, any claim(s) connected with providing, delivering, and/or supplying Fill.

Certification of: Delivery Firm/Transporter Supplier Manufacturer
 Wholesaler Broker Retailer
 Distributor Other _____

Type of Entity: Corporation General Partnership
 Limited Partnership Limited Liability Company
 Sole Proprietorship Other _____

Name of firm ("Firm"): _____

Mailing address: _____

Addresses of branch office used for this Project: _____

If subsidiary, name and address of parent company: _____

By my signature below, I hereby certify that I am aware of section 25260 of the Health and Safety Code and the sections referenced therein regarding the definition of hazardous material. I further certify on behalf of the Firm that all soils, aggregates, or related materials provided, delivered, and/or supplied or that will be provided, delivered, and/or supplied by this Firm to the Project Site are free of any and all hazardous material as defined in section 25260 of the Health and Safety Code. I further certify that I am authorized to make this certification on behalf of the Firm.

Date: _____

Proper Name of Developer: _____

Signature: _____

Print Name: _____

Title: _____

In addition to the requirement to provide this certification, Developer agrees that it shall provide all documentation requested by the District to confirm compliance with the requirements herein.

END OF DOCUMENT

CRIMINAL BACKGROUND INVESTIGATION / FINGERPRINTING CERTIFICATION

The undersigned does hereby certify to the governing board of the District that (1) he/she is a representative of the Developer, (2) he/she is familiar with the facts herein certified, (3) he/she is authorized and qualified to execute this certificate on behalf of Developer; and (4) that the following is true and correct:

1. **Education Code.** Developer has taken at least one of the following actions with respect to the Project (check all that apply):

_____ The Developer has complied with the fingerprinting requirements of Education Code section 45125.1 with respect to all Developer's employees and all of its subcontractors' employees who may have contact with District pupils in the course of providing services pursuant to the Contract, and the California Department of Justice has determined that none of those employees has been convicted of a felony, as that term is defined in Education Code section 45122.1. A complete and accurate list of Developer's employees and of all of its subcontractors' employees who may come in contact with District pupils during the course and scope of the Contract is attached hereto; and/or

_____ Pursuant to Education Code section 45125.2, Developer has installed or will install, prior to commencement of work , a physical barrier at the Project site, that will limit contact between Developer's employees and District pupils at all times; and/or

_____ Pursuant to Education Code section 45125.2, Developer certifies that all employees will be under the continual supervision of, and monitored by, an employee of the Developer who the California Department of Justice has ascertained has not been convicted of a violent or serious felony. The name and title of the employee who will be supervising Developer's employees and its subcontractors' employees is: **Name:** _____
Title: _____

_____ The Work on the Contract is at an unoccupied school site and no employee and/or subcontractor or supplier of any tier of Contract shall come in contact with the District pupils.

2. **Megan's Law (Sex Offenders).** I have verified and will continue to verify that the employees of Developer that will be on the Project site and the employees of the Subcontractor(s) that will be on the Project site are **not** listed on California's "Megan's Law" Website (<http://www.meganslaw.ca.gov/>).

Developer's responsibility for background clearance extends to all of its employees, subcontractors, and employees of subcontractors coming into contact with District pupils regardless of whether they are designated as employees or acting as independent contractors of the Developer.

Date: _____

Proper Name of Developer: _____

Signature: _____

Print Name: _____

Title: _____

ROOFING CONTRACT FINANCIAL INTEREST CERTIFICATION (Public Contract Code § 3006)

I, _____, _____
Name Name of Developer

certify that I have not offered, given, or agreed to give, received, accepted, or agreed to accept, any gift, contribution, or any financial incentive whatsoever to or from any person in connection with the roof project contract or subcontract on the Project. As used in this certification, "person" means any natural person, business, partnership, corporation, union, committee, club, or other organization, entity, or group of individuals.

Furthermore, I _____, _____
Name Name of Developer

certify that I do not have, and throughout the duration of the Contract, I will not have, any financial relationship in connection with the performance of the Contract with any architect, engineer, roofing consultant, materials manufacturer, distributor, or vendor that is not disclosed below.

I, _____, _____
Name Name of Developer

have the following financial relationships with an architect, engineer, roofing consultant, materials manufacturer, distributor, or vendor, or other person in connection with the following roof project contract:

Name of firm ("Firm"): _____

Mailing address: _____

Address of branch office used for this Project: _____

If subsidiary, name and address of parent company: _____

I certify that to the best of my knowledge, the contents of this disclosure are true, or are believed to be true.

Date: _____

Proper Name of Developer: _____

Signature: _____

Print Name: _____

Title: _____

END OF DOCUMENT

IRAN CONTRACTING ACT CERTIFICATION

Pursuant to Public Contract Code (PCC) section 2204, an Iran Contracting Act certification is required for solicitations of goods or services of \$1,000,000 or more.

To submit a proposal or bid to the District, you must complete **ONLY ONE** of the following two paragraphs. To complete paragraph 1, check the corresponding box **and** complete the certification for paragraph 1. To complete paragraph 2, simply check the corresponding box.

- 1. We are not on the current list of persons engaged in investment activities in Iran created by the California Department of General Services (“DGS”) pursuant to Public Contract Code § 2203(b), and we are not a financial institution extending twenty million dollars (\$20,000,000) or more in credit to another person, for 45 days or more, if that other person will use the credit to provide goods or services in the energy sector in Iran and is identified on the current list of persons engaged in investment activities in Iran created by DGS.

OR

- 2. We have received written permission from the District to submit a proposal pursuant to PCC 2203(c) or (d). *A copy of the written permission from the District is included with our proposal.*

CERTIFICATION FOR PARAGRAPH 1:

I, the official named below, certify that I am duly authorized to legally bind the proposer/bidder to the clause in paragraph 1. This certification is made under the laws of the State of California.

Date: _____

Proper Name of Developer: _____

Signature: _____

Print Name: _____

Title: _____

END OF DOCUMENT

LABOR COMPLIANCE PROGRAM

INFORMATION AND FORMS

The Developer shall comply with the labor compliance program (LCP) that is in effect on this Project which shall either be a District-operated program or the DIR's CMU (see below).

Effective January 1, 2012, the California Department of Industrial Relations (DIR) began operating a labor Compliance Monitoring Unit or "CMU" to monitor and enforce prevailing wage requirements on public works projects that receive state bond funding and on other projects that are legally required to use the CMU. (More information available at: <https://www.dir.ca.gov/dlse/cmu/cmu.html>.)

1. To monitor prevailing wage requirements on District projects, all contractors (including all subcontractors of every tier) must submit their certified payroll data directly to the DIR. The DIR has utilized a third party vendor to provide the electronic certified payroll service – "My LCM". Contractor payroll data can be entered manually or uploaded from major construction accounting and payroll programs into the electronic certified payroll reporting (My LCM) service at the DIR.
2. The service must be used by all awarding bodies and contractors for projects subject to CMU monitoring and enforcement for contracts awarded on or after January 1, 2012. A link is established for electronic certified payroll at <https://app.mylcm.com>. The site includes step-by-step instructions on how to assign contractors, manage employee profiles and submit payroll reports. (More information available at: https://www.dir.ca.gov/dlse/cmu/How_do_I_file_electronic_payroll_reports.html.)

END OF DOCUMENT

PERFORMANCE BOND (100% of Contract Price)
(Note: Developer must use this form, NOT a surety company form.)

KNOW ALL PERSONS BY THESE PRESENTS:

WHEREAS, the governing board ("Board") of the _____ School District ("District") and _____ ("Principal") have entered into a contract for the furnishing of all materials and labor, services and transportation, necessary, convenient, and proper to perform the following project:

_____ (Project Name)
("Project" or "Contract")

which Contract dated _____, 20____, and all of the Contract Documents attached to or forming a part of the Contract, are hereby referred to and made a part hereof, and

WHEREAS, said Principal is required under the terms of the Contract to furnish a bond for the faithful performance of the Contract;

NOW, THEREFORE, the Principal and _____ ("Surety") are held and firmly bound unto the Board of the District in the penal sum of:

_____ DOLLARS

(\$ _____), lawful money of the United States, for the payment of which sum well and truly to be made we bind ourselves, our heirs, executors, administrators, successors, and assigns jointly and severally, firmly by these presents, to:

- Perform all the work required to complete the Project; and
- Pay to the District all damages the District incurs as a result of the Principal's failure to perform all the Work required to complete the Project.

The condition of the obligation is such that, if the above bounden Principal, his or its heirs, executors, administrators, successors, or assigns, shall in all things stand to and abide by, and well and truly keep and perform the covenants, conditions, and agreements in the Contract and any alteration thereof made as therein provided, on his or its part to be kept and performed at the time and in the intent and meaning, including all contractual guarantees and warranties of materials and workmanship, and shall indemnify and save harmless the District, its trustees, officers and agents, as therein stipulated, then this obligation shall become null and void, otherwise it shall be and remain in full force and virtue.

As a condition precedent to the satisfactory completion of the Contract, the above obligation shall hold good for a period equal to the warranty and/or guarantee period of the Contract, during which time Surety's obligation shall continue if Contractor shall fail to make full, complete, and satisfactory repair, replace, and totally protect the District from loss or damage resulting from or caused by defective materials or faulty workmanship. The obligations of Surety hereunder shall continue so long as any obligation of Contractor remains. Nothing herein shall limit the District's rights or the Contractor's or Surety's obligations under the Contract, law or equity, including, but not limited to, California Code of Civil Procedure section 337.15.

The Surety, for value received, hereby stipulates and agrees that no change, extension of time, alteration, or addition to the terms of the Contract or to the Work to be performed thereunder shall in any way affect its obligation on this bond, and it does hereby waive notice of any such change, extension of time, alteration, or addition to the Contract Documents or to the Work.

Any claims under this bond may be addressed to the Surety at the following address. This cannot be the Contractor's broker for this bond, but must be an employee of the Surety or the Surety's legal counsel:

Attention: _____

Telephone No.: (_____) _____ - _____

Fax No.: (_____) _____ - _____

E-mail Address: _____

IN WITNESS WHEREOF, two (2) identical counterparts of this instrument, each of which shall for all purposes be deemed an original thereof, have been duly executed by the Principal and Surety above named, on the _____ day of _____, 20__.

Principal

Surety

(Name of Principal)

(Name of Surety)

(Signature of Person with Authority)

(Signature of Person with Authority)

(Print Name)

(Print Name)

(Name of California Agent of Surety)

(Address of California Agent of Surety)

(Telephone Number of California Agent of Surety)

Contractor must attach a Notarial Acknowledgment for all Surety's signatures and a Power of Attorney and Certificate of Authority for Surety. The California Department of Insurance must authorize the Surety to be an admitted surety insurer.

END OF DOCUMENT

PAYMENT BOND -- Contractor's Labor & Material Bond (100% of Contract Price)

(Note: Developer must use this form, NOT a surety company form.)

KNOW ALL PERSONS BY THESE PRESENTS:

WHEREAS, the governing board ("Board") of the _____ School District (or "District") and _____ ("Principal") have entered into a contract for the furnishing of all materials and labor, services and transportation, necessary, convenient, and proper to

_____ (Project Name)
("Project" or "Contract")

which Contract dated _____, 20____, and all of the Contract Documents attached to or forming a part of the Contract, are hereby referred to and made a part hereof, and

WHEREAS, pursuant to law and the Contract, the Principal is required, before entering upon the performance of the work, to file a good and sufficient bond with the body by which the Contract is awarded in an amount equal to 100 percent (100%) of the Contract price, to secure the claims to which reference is made in sections 3179 through 3214 and 3247 through 3252 of the Civil Code of California, and division 2, part 7, of the Labor Code of California.

NOW, THEREFORE, the Principal and _____ ("Surety") are held and firmly bound unto all laborers, material men, and other persons referred to in said statutes in the penal sum of:

_____ DOLLARS

(\$ _____), lawful money of the United States, being a sum not less than the total amount payable by the terms of Contract, for the payment of which sum well and truly to be made, we bind ourselves, our heirs, executors, administrators, successors, or assigns, jointly and severally, by these presents.

The condition of this obligation is that if the Principal or any of his or its subcontractors, of the heirs, executors, administrators, successors, or assigns of any, all, or either of them shall fail to pay for any labor, materials, provisions, provender, or other supplies, used in, upon, for or about the performance of the work contracted to be done, or for any work or labor thereon of any kind, or for amounts due under the Unemployment Insurance Act with respect to such work or labor, that the Surety will pay the same in an amount not exceeding the amount herein above set forth, and also in case suit is brought upon this bond, will pay a reasonable attorney's fee to be awarded and fixed by the Court, and to be taxed as costs and to be included in the judgment therein rendered.

It is hereby expressly stipulated and agreed that this bond shall inure to the benefit of any and all persons, companies, and corporations entitled to file claims under sections 3179 through 3214 and 3247 through 3252 of the Civil Code, so as to give a right of action to them or their assigns in any suit brought upon this bond.

Should the condition of this bond be fully performed, then this obligation shall become null and void; otherwise it shall be and remain in full force and affect.

The Surety, for value received, hereby stipulates and agrees that no change, extension of time, alteration, or addition to the terms of the Contract or to the Work to be performed thereunder shall in any way affect its obligation on this bond, and it does hereby waive notice of any such change, extension of time, alteration, or addition to the Contract Documents or to the Work.

IN WITNESS WHEREOF, two (2) identical counterparts of this instrument, each of which shall for all purposes be deemed an original thereof, have been duly executed by the Principal and Surety above named, on the _____ day of _____, 20__.

Principal

Surety

(Name of Principal)

(Name of Surety)

(Signature of Person with Authority)

(Signature of Person with Authority)

(Print Name)

(Print Name)

(Name of California Agent of Surety)

(Address of California Agent of Surety)

(Telephone Number of California Agent of Surety)

Contractor must attach a Notarial Acknowledgment for all Surety's signatures and a Power of Attorney and Certificate of Authority for Surety. The California Department of Insurance must authorize the Surety to be an admitted surety insurer.

END OF DOCUMENT

**Division 1 Documents
to
Lease-Leaseback Documents**

COORDINATION AND PROJECT MEETINGS24

CONSTRUCTION SCHEDULE - NETWORK ANALYSIS.....27

SUBMITTALS33

REGULATORY REQUIREMENTS36

TESTING LABORATORY SERVICES.....38

TEMPORARY FACILITIES AND CONTROLS42

SITE STANDARDS46

TEMPORARY TREE AND PLANT PROTECTION47

STORM WATER POLLUTION PREVENTION PLAN – CONSTRUCTION.....50

MATERIALS AND EQUIPMENT53

DELIVERY, STORAGE AND HANDLING.....55

CONTRACT CLOSEOUT AND FINAL CLEANING56

FIELD ENGINEERING58

CUTTING AND PATCHING.....59

DEMOLITION WASTE MANAGEMENT.....62

OPERATION AND MAINTENANCE DATA.....68

WARRANTIES.....70

RECORD DOCUMENTS.....71

COMMISSIONING72

COORDINATION AND PROJECT MEETINGS**1. GENERAL****1.1. SECTION INCLUDES**

- 1.1.1. Coordination Responsibilities of the Developer
- 1.1.2. Field Engineering Responsibilities of the Developer
- 1.1.3. Preconstruction Conference.
- 1.1.4. Progress Meetings.
- 1.1.5. Pre-Installation Conferences.
- 1.1.6. Post Construction Dedication.

1.2. COORDINATION RESPONSIBILITIES OF THE CONTRACTOR

- 1.2.1. Coordinate scheduling, submittals, and Work of the Specifications to assure efficient and orderly sequence of installation of interdependent construction elements, with provisions for accommodating items installed later.
- 1.2.2. Prior to commencement of a particular type or kind of work examine relevant information, contract documents, and subsequent data issued to the Project.
- 1.2.3. Verify that utility requirement characteristics of operating equipment are compatible with building utilities. Coordinate work of various sections having interdependent responsibilities for installing, connecting to, and placing in service, such equipment.
- 1.2.4. Closing up of holes, backfilling, and other covering up operations shall not proceed until all enclosed or covered work and inspections have been completed. Verify before proceeding.
- 1.2.5. Coordinate space requirements and installation of mechanical and electrical work which are indicated diagrammatically on Drawings. Follow routing shown for pipes, ducts, and conduit as closely as practicable; place runs parallel with line of building. Utilize spaces efficiently to maximize accessibility for other installations, for maintenance, and for repairs.
- 1.2.6. In finished areas except as otherwise indicated, conceal pipes, ducts, and wiring within the construction. Coordinate locations of fixtures and outlets with finish elements.
- 1.2.7. In locations where several elements of mechanical and electrical work must be sequenced and positioned with precision in order to fit into available space, prepare coordination drawings showing the actual conditions required for the installation. Prepare coordination drawings prior to purchasing, fabricating, or installing any of the elements required to be coordinated.
- 1.2.8. Closing up of walls, partitions or furred spaces, backfilling, and other covering up operations shall not proceed until all enclosed or covered work and inspections have been completed. Verify before proceeding.
- 1.2.9. Coordinate completion and clean up of Work of separate sections in preparation for completion and for portions of work designated for District's occupancy.
- 1.2.10. After District occupancy of Project, coordinate access to Site for correction of defective Work and Work not in accordance with Contract Documents, to minimize disruption of District's activities.
- 1.2.11. Coordinate all utility company work in accordance with the Contract Documents.

1.3. FIELD ENGINEERING RESPONSIBILITIES OF THE CONTRACTOR

- 1.3.1. Developer shall employ a Land Surveyor registered in the State of California and acceptable to the Construction Manager.
- 1.3.2. Control datum for survey is that established by District provided survey. Developer to locate and protect survey control and reference points.
- 1.3.3. Replace dislocated survey control points based on original survey control.
- 1.3.4. Provide field engineering services. Establish elevations, lines, and levels utilizing recognized engineering survey practices.
- 1.3.5. Upon completion of Work, submit certificate signed by the Land Surveyor, that elevations and locations of Work are in conformance with Contract Documents. Record deviations on Record Drawings.

1.4. PRECONSTRUCTION CONFERENCE

- 1.4.1. Construction Manager or Project Engineer will schedule a conference immediately after receipt of fully executed Contract Documents prior to Project mobilization.
- 1.4.2. Mandatory Attendance: Construction Manager, Project Engineer, Inspector of Record, Architect of Record, Developer, Developer's Project Manager, and Developer's Job/Project Superintendent.
- 1.4.3. Optional Attendance: Architect's consultants, subcontractors, and utility company representatives.
- 1.4.4. Construction Manager shall preside at conference and shall prepare and record minutes and distribute copies.
- 1.4.5. Agenda:
 - 1.4.5.1. Execution of District-Developer Agreement.
 - 1.4.5.2. Issue Notice to Proceed.
 - 1.4.5.3. Submission of executed bonds and insurance certificates.
 - 1.4.5.4. Distribution of Contract Documents.
 - 1.4.5.5. Submission of list of Subcontractors, list of Products, Schedule of Values, and Progress Schedule.
 - 1.4.5.6. Designation of responsible personnel representing the parties.
 - 1.4.5.7. Procedures for processing Construction Directives and Change Orders.
 - 1.4.5.8. Procedures for Request for Information.
 - 1.4.5.9. Procedures for testing and inspecting.
 - 1.4.5.10. Procedures for processing applications for payment.
 - 1.4.5.11. Procedures for Project closeout.
 - 1.4.5.12. Use of Premises.
 - 1.4.5.13. Work restrictions.
 - 1.4.5.14. District's occupancy requirements or options.
 - 1.4.5.15. Responsibility for temporary facilities and controls.
 - 1.4.5.16. Construction waste management and recycling.
 - 1.4.5.17. Parking availability.
 - 1.4.5.18. Office, work and storage areas.
 - 1.4.5.19. Equipment deliveries and priority.
 - 1.4.5.20. Security.
 - 1.4.5.21. Progress cleaning.

1.5. PROGRESS MEETINGS

- 1.5.1. Construction Manager shall schedule and administer meetings throughout progress of the Work at a minimum of every week.
- 1.5.2. Construction Manager or Project Engineer will make arrangements for meetings, prepare agenda, and preside at meetings. Construction Manager shall record minutes (Field Reports), and distribute copies.
- 1.5.3. Attendance Required: Project Manager, Job Superintendent, Construction Manager, Project Engineer, Project Inspector (Inspector of Record), Architect of Record, Subcontractors, and suppliers as appropriate to agenda topics for each meeting.
- 1.5.4. Agenda:
 - 1.5.4.1. Review minutes of previous meetings. (Field Reports)
 - 1.5.4.2. Safety, and jobsite visits
 - 1.5.4.3. Review of Work progress.
 - 1.5.4.4. Field observations, problems, and decisions.
 - 1.5.4.5. Identification of problems which impede planned progress.
 - 1.5.4.6. Review of submittals schedule and status of submittals.
 - 1.5.4.7. Review of off-site fabrication and delivery schedules.
 - 1.5.4.8. Maintenance of construction schedule.
 - 1.5.4.9. Corrective measures to regain projected schedules.
 - 1.5.4.10. Planned progress during succeeding work period.
 - 1.5.4.11. Coordination of projected progress.
 - 1.5.4.12. Maintenance of quality and work standards.
 - 1.5.4.13. Effect of proposed changes on progress schedule and coordination.

1.5.4.14. Other business relating to Work.

1.5.5. District has authority to schedule meetings other than those listed, as necessary.

1.6. PRE-INSTALLATION CONFERENCES

When required in individual specification section, or requested by the District Developer shall convene a pre-installation conference prior to commencing work of the section. Refer to individual specification section for timing requirements of conference.

1.6.1. Developer shall require his/her subcontractors and suppliers directly affecting, or affected by, work of the specific section to attend.

1.6.2. Notify the Construction Manager, Project Engineer, Inspector of Record, and Architect of Record four (4) days in advance of meeting date.

1.6.3. The pre-installation conference may coincide with a regularly scheduled progress meeting.

1.6.4. Developer shall prepare agenda, preside at conference, record minutes, and distribute copies within two (2) days after conference to participants.

1.6.5. The purpose of the meeting will be to review Contract Documents, conditions of installation, preparation and installation procedures, and coordination with related work and manufacturer's recommendations.

1.6.6. Pre-installation Schedule: As a minimum, Work being installed under the Contract Documents technical sections will require pre-installation conferences. Developer shall review the technical specifications and add all additional requirements for pre-installation meetings contained in those sections.

1.7. POST CONSTRUCTION DEDICATION

1.7.1. Attendance Required: Project Superintendent, Developer, Project Manager, major subcontractors, Construction Manager, Project Engineer, Inspector of Record, and Architect of Record.

1.7.2. Preparation prior to Dedication: Developer and appropriate subcontractors and suppliers shall:

1.7.3. Assist District in operation of mechanical devices and systems.

1.7.3.1. Verify operation and adjust controls for communication systems.

1.7.3.2. Assist District in operation of lighting systems.

END OF DOCUMENT

CONSTRUCTION SCHEDULE - NETWORK ANALYSIS**1. GENERAL****1.1. REFERENCES**

- 1.1.1. Construction Planning and Scheduling Manual - A Manual for General Developers and the Construction Industry, The Associated General Developers of America (AGC).
- 1.1.2. CSI - Construction Specifications Institute MP-2-1 Master Format.
- 1.1.3. U.S. National Weather Service - Local Climatological Data.

1.2. PERFORMANCE REQUIREMENTS

- 1.2.1. All Developer's schedules shall comply with the baseline and milestones as indicated in the draft "Program Schedule" the District provided as a draft **Exhibit "F"** to the Facilities Lease.
- 1.2.2. Ensure adequate scheduling during construction activities so Work may be prosecuted in an orderly and expeditious manner within stipulated Contract Time.
- 1.2.3. Ensure coordination of Developer and subcontractors at all levels.
- 1.2.4. Ensure coordination of submittals, fabrication, delivery, erection, installation, and testing of Products, materials and equipment.
- 1.2.5. Ensure on-time delivery of District furnished Products, materials and equipment.
- 1.2.6. Ensure coordination of jurisdictional reviews.
- 1.2.7. Prepare applications for payment.
- 1.2.8. Monitor progress of Work.
- 1.2.9. Prepare proper requests for changes to Contract Time.
- 1.2.10. Prepare proper requests for changes to Construction Schedule.
- 1.2.11. Assist in detection of schedule delays and identification of corrective actions.

1.3. QUALITY ASSURANCE

- 1.3.1. Perform scheduling work in accordance with Construction Planning and Scheduling Manual published by the AGC.
- 1.3.2. Maintain one copy of Construction Planning and Scheduling Manual on Site.
- 1.3.3. In the event of discrepancy between the AGC publication and the Contract Documents, provisions of the Contract Documents shall govern.

1.4. QUALIFICATIONS**1.4.1. Scheduler:**

- 1.4.1.1. Developer shall retain a construction scheduler to work in enough capacity to perform all of the Developer's requirements to prepare the Construction Schedule. The Scheduler shall plan, coordinate, execute, and monitor a cost/resource loaded critical path method (CPM) schedule as required for Project and have a minimum of five (5) years direct experience using CPM.
- 1.4.1.2. Scheduler will cooperate with District and shall be available on site for monitoring, maintaining and updating schedules in a timely manner.
- 1.4.1.3. District has the right to reject the Scheduler based upon a lack of experience as required by this Document or based on lack of performance and timeliness of schedule submittals/fragnets on past projects. Developer shall within seven (7) calendar days of District's rejection, propose another scheduler who meets the experience requirements stated above.

- 1.4.2. **Administrative Personnel:** Five (5) years minimum experience in using and monitoring schedules on comparable projects.

1.5. SUBMITTALS

- 1.5.1. Submission of submittals pursuant to "Developer's Submittals And Schedules" in Exhibit "D." Adobe "PDF" files are not acceptable.
- 1.5.2. Submit Short Interval Schedule at each Construction Progress Meeting.
- 1.5.3. Submit Time Adjustment Schedule within five (5) days of commencement of a claimed delay.
- 1.5.4. Submit Recovery Schedules as required for timely completion of Work or when

demanded by the District.

- 1.5.5. Submit job cost reports when demanded by the District.
- 1.5.6. Submit one (1) reproducible and two (2) copies of each schedule and cost report.
- 1.5.7. Submit large format plotted schedules monthly or at the request of the District or Construction Manager.

1.6. REVIEW AND EVALUATION

- 1.6.1. Developer shall participate in joint review of Construction Schedule and Reports with District and Construction Manager.
- 1.6.2. Within seven (7) days of receipt of District and Construction Manager's comments provide satisfactory revision to Construction Schedule or adequate justification for activities in question.
- 1.6.3. In the event that an activity or element of Work is not detected by District or Construction Manager review, such omission or error shall be corrected by next scheduled update and shall not affect Contract Time.
- 1.6.4. Acceptance by District of corrected Construction Schedule shall be a condition precedent to making any progress payments.
- 1.6.5. Cost-loaded values of Construction Schedule shall be basis for determining progress payments.
- 1.6.6. Review and acceptance by District and Construction Manager of Preliminary Work Schedule or Construction Schedule does not constitute responsibility whatsoever for accuracy or feasibility of schedules nor does such acceptance expressly or impliedly warrant, acknowledge or admit reasonableness of activities, logic, duration, manpower, cost or equipment loading stated or implied on schedules.

1.7. FORMAT

- 1.7.1. Prepare diagrams and supporting mathematical analyses using Precedence Diagramming Method, under concepts and methods outlined in AGC Construction Planning and Scheduling Manual.
- 1.7.2. **Listings:** Reading from left to right, in ascending order for each activity.
- 1.7.3. **Diagram Size:** 42 inches maximum height x width required.
- 1.7.4. **Scale and Spacing:** To allow for legible notations and revisions.
- 1.7.5. Illustrate order and interdependence of activities and sequence of Work.
- 1.7.6. Illustrate complete sequence of construction by activity.
- 1.7.7. Provide legend of symbols and abbreviations used.

1.8. COST AND SCHEDULE REPORTS

- 1.8.1. **Activity Analysis:** Tabulate each activity of network diagram and identify for each activity:
 - 1.8.1.1. Description.
 - 1.8.1.2. Interface with outside contractors or agencies.
 - 1.8.1.3. Number.
 - 1.8.1.4. Preceding and following number.
 - 1.8.1.5. Duration.
 - 1.8.1.6. Earliest start date, earliest finish date.
 - 1.8.1.7. Actual start date, actual finish date.
 - 1.8.1.8. Latest start date, latest finish date.
 - 1.8.1.9. Total and free float.
 - 1.8.1.10. Identification of critical path activity.
 - 1.8.1.11. Monetary value keyed to Schedule of Values.
 - 1.8.1.12. Manpower requirements.
 - 1.8.1.13. Responsibility.
 - 1.8.1.14. Percentage complete.
 - 1.8.1.15. Variance positive or negative.
- 1.8.2. **Cost Report:** Tabulate each activity of network diagram and identify for each activity:
 - 1.8.2.1. Description.
 - 1.8.2.2. Number.
 - 1.8.2.3. Total cost.

- 1.8.2.4. Percentage complete.
- 1.8.2.5. Value prior to current period.
- 1.8.2.6. Value this period.
- 1.8.2.7. Value to date.
- 1.8.3. **Required Sorts:** List activities in sorts or groups:
 - 1.8.3.1. By activity number.
 - 1.8.3.2. By amount of float time in order of early start.
 - 1.8.3.3. By responsibility in order of earliest start date.
 - 1.8.3.4. In order of latest start dates.
 - 1.8.3.5. In order of latest finish dates.
 - 1.8.3.6. Application for payment sorted by Schedule of Values.
 - 1.8.3.7. Listing of activities on critical path.
- 1.8.4. Listing of basic input data which generates schedule.

1.9. CONSTRUCTION SCHEDULE

- 1.9.1. Developer shall develop and submit a cost loaded preliminary schedule of construction (or Preliminary Construction Schedule) as required by this Document and the Contract Documents. It shall be submitted in computer generated network format and shall be organized by Activity Codes representing the Developer's intended sequencing of the Work, and with time scaled network diagrams of activities. The Preliminary Construction Schedule shall include activities such as mobilization, preparation of submittals, specified review periods, procurement items, fabrication items, milestones, and all detailed construction activities.
- 1.9.2. Upon District's acceptance of the Preliminary Construction Schedule, Developer shall update the accepted Preliminary Construction Schedule until Developer's Construction Schedule is fully developed and accepted. Once approved by District, this shall become the Construction Schedule. This schedule shall include and identify all tasks that are on the Project's critical path with a specific determination of the start and completion of each critical path task, all contract milestones and each milestone's completion date(s) as may be required by the District, and the date of Project Completion. Since updates to the Construction Schedule are the basis for payment to Developer, submittal and acceptance of the Construction Schedule and updates shall be a condition precedent to making of monthly payments, as indicated in the General Construction Provisions (Exhibit "D" to the Facilities Lease).
- 1.9.3. Failure to submit an adequate or accurate Preliminary Construction Schedule, Construction Schedule, updates thereto or failure to submit on established dates, will be considered a breach of Contract.
- 1.9.4. Failure to include any activity shall not be an excuse for completing all Work by required Completion Date.
- 1.9.5. Activities of long intervals shall be broken into increments no longer than fourteen (14) days or a value over \$20,000.00 unless approved by the District or it is non-construction activity for procurement and delivery.
- 1.9.6. The Construction Schedule shall comply with the following and include the following:
 - 1.9.6.1. Provide a written narrative describing Developer's approach to mobilization, procurement, and construction during the first thirty (30) calendar days including crew sizes, equipment and material delivery, Site access, submittals, and permits.
 - 1.9.6.2. Shall designate critical path or paths.
 - 1.9.6.3. Procurement activities to include mobilization, shop drawings and sample submittals.
 - 1.9.6.4. Identification of key and long-lead elements and realistic delivery dates.
 - 1.9.6.5. Construction activities in units of whole days limited to fourteen (14) days for each activity except non-construction, procurement and delivery.
 - 1.9.6.6. Approximate cost and duration of each activity.
 - 1.9.6.7. Shall contain seasonal weather considerations.
 - 1.9.6.8. Indicate a date for Project Completion that is no later than Completion

- Date subject to any time extensions processed as part of a Change Order.
- 1.9.6.9. Conform to mandatory dates specified in the Contract Documents.
 - 1.9.6.10. Developer shall allow for inclement weather in the Proposed Baseline Schedule by incorporating an activity titled "Rain Day Impact Allowance" as the last activity prior to the Completion Milestone. No other activities may be concurrent with it. The duration of the Rain Day Impact Allowance activity will in accordance with the Contract Documents, including "Computation of Time / Adverse Weather" in Exhibit "D" , and will be calculated from the Notice to Proceed until the Completion.
 - 1.9.6.11. Level of detail shall correspond to complexity of work involved.
 - 1.9.6.12. Indicate procurement activities, delivery, and installation of District furnished material and equipment.
 - 1.9.6.13. Designate critical path or paths.
 - 1.9.6.14. Subcontractor work at all levels shall be included in schedule.
 - 1.9.6.15. As developed shall show sequence and interdependence of activities required for complete performance of Work.
 - 1.9.6.16. Shall be logical and show a coordinated plan of Work.
 - 1.9.6.17. Show order of activities and major points of interface, including specific dates of completion.
 - 1.9.6.18. Duration of activities shall be coordinated with subcontractors and suppliers and shall be best estimate of time required.
 - 1.9.6.19. Shall show description, duration and float for each activity.
 - 1.9.7. **Activity.** An activity shall meet the following criteria:
 - 1.9.7.1. Any portion or element of Work or action that is precisely described, readily identifiable, and is a function of a logical sequential process.
 - 1.9.7.2. Descriptions shall be clear and concise. Beginning and end shall be readily verifiable. Starts and finishes shall be scheduled by logical restraints.
 - 1.9.7.3. Responsibility shall be identified with a single performing entity.
 - 1.9.7.4. Additional codes shall identify building, floor, and CSI classification.
 - 1.9.7.5. Assigned dollar value (cost-loading) of each activity shall cumulatively equal total contract amount. Mobilization, bond and insurance costs shall be separate. General requirement costs, overhead, profit, shall be prorated throughout all activities. Activity costs shall correlate with Schedule of Values.
 - 1.9.7.6. Each activity shall have manpower-loading assigned.
 - 1.9.7.7. Major construction equipment shall be assigned to each activity.
 - 1.9.7.8. Activities labeled start, continue or completion are not allowed.
 - 1.9.8. **Equipment and Materials.** For major equipment and materials show a sequence of activities including:
 - 1.9.8.1. Preparation of shop drawings and sample submissions.
 - 1.9.8.2. Review of shop drawings and samples.
 - 1.9.8.3. Finish and color selection.
 - 1.9.8.4. Fabrication and delivery.
 - 1.9.8.5. Erection or installation.
 - 1.9.8.6. Testing.
 - 1.9.9. Include a minimum of fifteen (15) days prior to Completion Date for punch lists and clean up. No other activities shall be scheduled during this period.
 - 1.10. **SHORT INTERVAL SCHEDULE**
 - 1.10.1. The Four-Week Rolling Schedule shall be based on the most recent District Accepted Construction Schedule or Update. It shall include weekly updates to all construction, submittal, fabrication/procurement, and separate Work Contract activities. Developer shall ensure that it accurately reflects the current progress of the Work.
 - 1.10.2. Shall be fully developed horizontal bar-chart-type schedule directly derived from Construction Schedule.
 - 1.10.3. Prepare schedule on sheet of sufficient width to clearly show data.

- 1.10.4. Provide continuous heavy vertical line identifying first day of week.
- 1.10.5. Provide continuous subordinate vertical line identifying each day of week.
- 1.10.6. Identify activities by same activity number and description as Construction Schedule.
- 1.10.7. Show each activity in proper sequence.
- 1.10.8. Indicate graphically sequences necessary for related activities.
- 1.10.9. Indicate activities completed or in progress for previous two (2) week period.
- 1.10.10. Indicate activities scheduled for succeeding two (2) week period.
- 1.10.11. Further detail may be added if necessary to monitor schedule.

1.11. REQUESTED TIME ADJUSTMENT SCHEDULE

- 1.11.1. Updated Construction Schedule shall not show a Completion Date later than the Contract Time, subject to any time extensions processed as part of a Change Order.
- 1.11.2. If an extension of time is requested, a separate schedule entitled "Requested Time Adjustment Schedule" shall be submitted to District and Architect.
- 1.11.3. Indicate requested adjustments in Contract Time which are due to changes or delays in completion of Work.
- 1.11.4. Extension request shall include forecast of Project Completion date and actual achievement of any dates listed in Contract Documents.
- 1.11.5. To the extent that any requests are pending at time of any Construction Schedule update, Time Adjustment Schedule shall also be updated.
- 1.11.6. Schedule shall be a time-scaled network analysis.
- 1.11.7. Accompany schedule with formal written time extension request and detailed impact analysis justifying extension.
- 1.11.8. Time impact analysis shall demonstrate time impact based upon date of delay, and status of construction at that time and event time computation of all affected activities. Event times shall be those as shown in latest Construction Schedule.
- 1.11.9. Activity delays shall not automatically constitute an extension of Contract Time.
- 1.11.10. Failure of subcontractors shall not be justification for an extension of time.
- 1.11.11. Float is not for the exclusive use or benefit of any single party. Float time shall be apportioned according to needs of project, as determined by the District.
- 1.11.12. Float suppression techniques such as preferential sequencing, special lead/lag logic restraints, extended activity durations, or imposed dates shall **not** be allowed without the prior written permission of the District.
- 1.11.13. Extensions will be granted only to extent that time adjustments to activities exceed total positive float of the critical path and extends Completion date.
- 1.11.14. District shall not have an obligation to consider any time extension request unless requirements of Contract Documents, and specifically, but not limited to these requirements are complied with.
- 1.11.15. District shall not be responsible or liable for any construction acceleration due to failure of District to grant time extensions under Contract Documents should requested adjustments in Contract Time not substantially comply with submission and justification requirements of Contract for time extension requests.
- 1.11.16. In the event a Requested Time Adjustment Schedule and Time Impact Analysis are not submitted within ten (10) days after commencement of a delay it is mutually agreed that delay does not require a Contract Time extension.

1.12. RECOVERY SCHEDULE

- 1.12.1. When activities are behind Construction Schedule a supplementary Recovery Schedule shall be submitted.
- 1.12.2. Developer shall prepare and submit to the District a Recovery Schedule at any time requested by the District, at no cost to the District.
- 1.12.3. Form and detail shall be sufficient to explain and display how activities will be rescheduled to regain compliance with Construction Schedule and to complete the Work by the Completion Date.
- 1.12.4. Maximum duration shall be one (1) month and shall coincide with payment period.
- 1.12.5. Ten (10) days prior to expiration of Recovery Schedule, Developer shall have to show verification to determine if activities have regained compliance with Construction

Schedule. Based upon this verification the following will occur:

- 1.12.5.1. Supplemental Recovery Schedule will be submitted to address subsequent payment period
- 1.12.5.2. Construction Schedule will be resumed.

1.13. UPDATING SCHEDULES

- 1.13.1. Review and update schedule at least ten (10) days prior to submitting an Application for Payment.
- 1.13.2. Maintain schedule to record actual prosecution and progress.
- 1.13.3. Identify approved Change Orders which affect schedule as separate new activities.
- 1.13.4. No other revisions shall be made to schedule unless authorized by District.
- 1.13.5. **Written Narrative Report:** Developer shall include a written report to explain the Monthly Schedule Update. The narrative shall, at a minimum include the following headings with appropriate discussions of each topic:
 - 1.13.5.1. Activities or portions of activities completed during previous reporting period.
 - 1.13.5.2. Actual start dates for activities currently in progress.
 - 1.13.5.3. Deviations from critical path in days ahead or behind.
 - 1.13.5.4. List of major construction equipment used and any equipment idle.
 - 1.13.5.5. Number of personnel by craft engaged on Work during reporting period.
 - 1.13.5.6. Progress analysis describing problem areas.
 - 1.13.5.7. Current and anticipated delay factors and their impact.
 - 1.13.5.8. Proposed corrective actions and logic revisions for Recovery Schedule.
 - 1.13.5.9. Proposed modifications, additions, deletions and changes in logic of Construction Schedule.
 - 1.13.5.10. In updating the Schedule, Developer shall not modify Activity ID numbers, schedule calculation rules/criteria, or the Activity Coding Structure required.
- 1.13.6. Schedule update will form basis upon which progress payments will be made.
- 1.13.7. District will not be obligated to review or process Application for Payment until schedule and Progress Report have been submitted.

1.14. DISTRIBUTION

- 1.14.1. Following joint review and acceptance of updated schedules distribute copies to District, Architect, and all other concerned parties.
- 1.14.2. Instruct recipients to promptly report in writing any problem anticipated by projections shown in schedule.

2. PRODUCTS

2.1. SCHEDULING SOFTWARE

Developer shall utilize District approved software for scheduling software and shall employ the Critical Path Method (CPM) in the development and maintenance of the Construction Schedule. The scheduling software shall be capable of being resource loaded with manpower, costs and materials. It shall also be capable of generating time-scaled logic diagrams, resource histograms and profiles, bar charts, layouts and reports with any and/or all activity detail.

2.2. ELECTRONIC DATA

Provide compact disk(s) that contain a back-up of the Proposed Baseline Schedule data on it. The electronic P6 files shall be saved in “.XER” type format.

END OF DOCUMENT

SUBMITTALS**1. GENERAL****1.1. SUBMITTAL PROCEDURES – USE OF CONSTRUCTWARE**

- 1.1.1. DEVELOPER SHALL UTILIZE DISTRICT APPROVED SOFTWARE FOR THE SUBMITTAL PROCESS.**
- 1.1.2. Developer shall transmit each submittal in conformance with requirements of this Document. For each submittal, Developer shall:
- 1.1.2.1. Sequentially number the transmittal forms. Resubmitted submittals must have the original number with an alphabetic suffix;
 - 1.1.2.2. Identify Project and Architect's project number, Developer, Subcontractor or supplier; pertinent Drawing sheet and detail number(s), and specification Section number, as appropriate;
 - 1.1.2.3. Apply Developer's stamp, signed or initialed certifying that review, verification of Products required, field dimensions, adjacent construction work, and coordination of information is in accordance with the requirements of the Work and Contract Documents. Submittals without Developer's stamp and signature will be returned without review.
- 1.1.3. Coordinate preparation and processing of submittals with performance of Work. Transmit each submittal sufficiently in advance of performance of Work to avoid delay.
- 1.1.3.1. Coordinate each submittal with fabrication, purchasing, testing, delivery, other submittals, and related activities that require sequential activity.
 - 1.1.3.2. Coordinate transmittal of different types of submittals for related parts of Work so processing will not be delayed because of the need to review submittals concurrently for coordination.
 - 1.1.3.3. Architect reserves the right to withhold action on a submittal requiring coordination with other submittals until related submittals are received.
- 1.1.4. Comply with Contract Documents for list of submittals and time requirements for scheduled performance of Work.
- 1.1.5. No extension of Contract Time will be authorized because of failure to transmit submittals to the Architect sufficiently in advance of the Work to permit processing.
- 1.1.6. Identify variations from Contract Documents and Product or system limitations which may be detrimental to successful performance of the completed Work.
- 1.1.7. Provide space for Developer and Architect review stamps.
- 1.1.8. Revise and resubmit submittals as required, identify all changes made since previous submittal.
- 1.1.9. Distribute copies of reviewed submittals to concerned parties. Instruct parties to promptly report any inability to comply with provisions.
- 1.1.10. Submittals not requested will not be recognized or processed. Submittals not requested will be returned without review.

1.2. SHOP DRAWINGS

- 1.2.1. Do not reproduce Contract Documents or copy standard information as the basis of shop drawings. Standard information prepared without specific reference to the Project is not a shop drawing.
- 1.2.2. Do not use or allow others to use Shop Drawings which have been submitted and have been rejected.

1.3. ELECTRONIC SUBMITTAL PROCESS**1.3.1. Submittal Procedure for Large Format shop drawings.**

- 1.3.1.1. Developer shall provide six (6) paper copies and of the large format Shop Drawings directly to the District and the Construction Manager (CM) and Developer will provide an electronic transmittal (with a detailed description of the submittal including the subject, specification number and number of drawings) using the District approved software/program.

- 1.3.1.2. Developer shall verify that the Schedule of Submittals and all submittal log(s) are accurate and up to date.
- 1.3.1.3. The District and Architect will review and markup each Submittal and provide changes to Developer for Developer's incorporation into the Submittal.
- 1.3.1.4. This process will continue until the Developer has provided a Submittal that is acceptable to the District and the Architect.
- 1.3.1.5. Once a Submittal is accepted, the District will provide a final accepted Submittal to the Developer and the Developer will closeout that one Submittal.
- 1.3.1.6. Developer shall send one (1) copy of the completed record submittal of the large format documents to a vendor (Ford Graphics is suggested) and using the District approved software/program.

1.3.2. Product Data, Calculations and Small Format Drawings

- 1.3.2.1. Developer shall upload/post one (1) electronic copy (from manufacturer's website or pre-scanned) of the product literature, data, calculations, and/or small format shop drawings using the District approved software/program with a Transmittal (with a detailed description of the submittal) directly to the CM.
- 1.3.2.2. The District and Architect will review and markup each Submittal and provide changes to Developer for Developer's incorporation into the Submittal.
- 1.3.2.3. This process will continue until the Developer has provided a Submittal that is acceptable to the District and the Architect.
- 1.3.2.4. Once a Submittal is accepted, the District will provide a final accepted Submittal to the Developer and the Developer will closeout that one Submittal.
- 1.3.2.5. Developer shall send one (1) copy of the completed record submittal of the large format documents to a vendor for scanning and posting using the District approved software/program.

1.3.3. Sample Submittal Procedure – (Product / Assembly Samples)

- 1.3.3.1. Developer shall provide four (4) physical samples directly to the District and the CM and Developer will provide an electronic transmittal (with a detailed description of the submittal including the subject, specification number and number of drawings) using the District approved software/program.
- 1.3.3.2. The District and Architect will review and markup each Submittal and provide changes to Developer for Developer's incorporation into the Submittal.
- 1.3.3.3. This process will continue until the Developer has provided a Submittal that is acceptable to the District and the Architect.
- 1.3.3.4. Once a Submittal is accepted, the District will provide a final accepted Submittal to the Developer and the Developer will closeout that one Submittal.
- 1.3.3.5. Developer shall send one (1) copy of the completed record submittal of the large format documents to a vendor (Ford Graphics is suggested) for using the District approved software/program.

1.4. PRODUCT DATA

In addition to the above requirements, mark each copy to identify applicable products, models, options, and other data. Supplement manufacturers' standard data to provide information unique to this Project.

1.5. SAMPLES

- 1.5.1. In addition to the above requirements, submit samples to illustrate functional and aesthetic characteristics of the Product in accordance with this Document, with integral parts and attachment devices. Coordinate sample submittals for interfacing work.
- 1.5.2. Where specific colors or patterns are not indicated, provide materials and products specified in the full range of color, texture and pattern for selection by District. Range shall include standard stocked color/texture/pattern, standard color/texture/pattern not stocked, but available from manufacturer, and special color/ texture/pattern available from manufacturer as advertised in product data and brochures. Unless otherwise indicated in individual specification sections, District may select from any range at no additional cost to District.
- 1.5.3. Include identification on each sample, with full Project information.
- 1.5.4. Submit the number of samples that Developer requires, plus one that will be retained by

Architect and one by District.

- 1.5.5. Reviewed samples which may be used in the Work are indicated in individual specification Sections.

1.6. MANUFACTURER'S INSTRUCTION

- 1.6.1. When specified in individual specification Sections, submit manufacturers' printed instructions for delivery, storage, assembly, installation, start-up, adjusting, and finishing, in quantities specified for Product Data.
- 1.6.2. Identify conflicts between manufacturers' instructions and Contract Documents.

1.7. MANUFACTURER'S CERTIFICATES

- 1.7.1. When specified in individual specification Sections, submit manufacturers' certificate to Architect for review, in quantities specified for Product Data.
- 1.7.2. Indicate material or Product conforms to or exceeds specified requirements. Submit supporting reference date, affidavits, and certifications as appropriate.
- 1.7.3. Certificates may be recent or previous test results on material or Product, but must be acceptable to District.

1.8. MOCK-UP

- 1.8.1. Where indicated, provide mock-ups as required. Mock-ups shall be prepared per the specifications and shall accurately and reasonably represent the quality of construction the Developer will provide. If the mock-up or portions thereof do not adequately represent the quality of the work specified, the Developer shall modify it as needed.
- 1.8.2. Once completed to the District's satisfaction, the mock-up shall serve as the standard of quality for the work.
- 1.8.3. All mock-ups, at District's option, shall remain the property of the District. If not required by the District, Developer shall remove and dispose of the mock-up.
- 1.8.4. Where indicated, on-site mock-ups, if accepted, may be integrated into the Work.

1.9. DEFERRED APPROVAL REQUIREMENTS

- 1.9.1. Installation of deferred approval items shall not be started until detailed plans, specifications, and engineering calculations have been accepted and signed by the Architect or Engineer in general responsible charge of design and signed by a California registered Architect or professional engineer who has been delegated responsibility covering the work shown on a particular plan or specification and approved by the Division of the State Architect (DSA). Deferred approval items for this Project are as indicated in the Contract Documents.
- 1.9.2. Deferred approval drawings and specifications become part of the approved documents for the Project when they are submitted to and approved by DSA.
- 1.9.3. Submit material using electronic submittal process as defined above.
- 1.9.4. Identify and specify all supports, fasteners, spacing, penetrations, etc., for each of the deferred approval items, including calculations for each and all fasteners.
- 1.9.5. Submit documents to Architect for review prior to requesting that the Architect forward it to the DSA.
- 1.9.6. Documents shall bear the stamp and signature of the Structural, Mechanical, or Electrical Engineer licensed in California who is responsible for that work.
- 1.9.7. Architect and its subconsultants will review the documents only for conformance with design concept. The Architect will then forward the Submittal to DSA for approval.
- 1.9.8. Developer shall respond to review comments made by DSA and revise and resubmit submittal to the Architect for re-submittal to DSA for final approval.

END OF DOCUMENT

REGULATORY REQUIREMENTS**1. GENERAL****1.1. DESCRIPTION**

This section covers the general requirements for regulatory requirements pertaining to the Work and is supplementary to all other regulatory requirements mentioned or referenced elsewhere in the Contract Documents.

1.2. REQUIREMENTS OF REGULATORY AGENCIES

- 1.2.1.** All statutes, ordinances, laws, rules, codes, regulations, standards, and the lawful orders of all public authorities having jurisdiction of the Work, are hereby incorporated into the Contract Documents as if repeated in full herein and are intended to be included in any reference to Code or Building Code, unless otherwise specified, including, without limitation, the references in the list below. Developer shall make available at the Site copies of all the listed documents applicable to the Work as the District and/or Architect may request, including, without limitation, applicable portions of the California Code of Regulations (C.C.R.).
- 1.2.2.** This Project shall be governed by applicable regulations, including, without limitation, the State of California's Administrative Regulations for the Division of the State Architect-Structural Safety (DSA/SS), Chapter 4, Part 1, Title 24, C.C.R., and the most current version on the date the Contract is executed and as it pertains to school construction including, without limitation:
- 1.2.2.1. Test and testing laboratory pursuant to Section 4-335 (District shall pay for the testing laboratory).
- 1.2.2.2. All special inspections pursuant to Section 4-333(d).
- 1.2.2.3. Developer shall submit verified reports pursuant to Section 4-336 & 4-343(c).
- 1.2.2.4. Administration
- 1.2.2.4.1. Duties of the Architect and Engineers shall be pursuant to Section and 4-341.
- 1.2.2.4.2. Duties of Developer shall be pursuant Section 4-343.
- 1.2.2.4.3. Verified Reports shall be pursuant to Section 4-336.
- 1.2.2.5. Developer shall keep and make available a copy of Part 1 and 2 of the most current version of C.C.R., Title 24 at the Site during construction.
- 1.2.2.6. Developer shall notify the Division of State Architect (DSA) upon the start of construction pursuant to Section 4-331.
- 1.2.2.7. Addenda and Change Orders shall be pursuant to Section 4-338.
- 1.2.3.** Items of deferred approval shall be clearly marked on the first sheet of the Architect's and/or Engineer's approved Drawings. All items later submitted for approval shall be pursuant to Title 24 requirements to the DSA.
- 1.2.3.1. 2010 Building Standards Administrative Code, C.C.R., Title 24, Part 1..
- 1.2.3.2. 2010 California Building Code (CBC), C.C.R. Part 2, Title 24; (2009 International Building Code and 2010 California Amendments).
- 1.2.3.3. 2010 California Electrical Code (CEC), C.C.R., Title 24, Part 3; (2008 National Electrical Code and 2010 California Amendments).
- 1.2.3.4. 2010 California Mechanical Code (CMC), C.C.R., Title 24, Part 4 ; (2009 Uniform Mechanical Code and 2010 California Amendments).
- 1.2.3.5. 2010 California Plumbing Code (CPC), C.C.R., Title 24, Part 5; (2009 Uniform Plumbing Code and 2010 California Amendments).
- 1.2.3.6. 2010 California Energy Code (CEC), Part 6, Title 24 C.C.R.
- 1.2.3.7. 2010 California Fire Code (CFC), C.C.R., Title 24, Part 9; (2009 International Fire Code and 2010 California Amendments).
- 1.2.3.8. 2010 California Green Building Standards Code (Calgreen), Part 11, Title 24 C.C.R.
- 1.2.3.9. 2010 California Referenced Standards Code, C.C.R., Title 24, Part 12.
- 1.2.3.10. State Fire Marshal Regulations, C.C.R., Title 19, Public Safety.
- 1.2.3.11. Partial List of Applicable NFPA Standards:

- 1.2.3.11.1. NFPA 13 - Automatic Sprinkler System.
- 1.2.3.11.2. NFPA 14 - Standpipes Systems.
- 1.2.3.11.3. NFPA 17A - Wet Chemical System
- 1.2.3.11.4. NFPA 24 - Private Fire Mains.
- 1.2.3.11.5. (California Amended) NFPA 72 - National Fire Alarm Codes.
- 1.2.3.11.6. NFPA 253 - Critical Radiant Flux of Floor Covering System.
- 1.2.3.11.7. FPA 2001 - Clean Agent Fire Extinguishing Systems.
- 1.2.3.12. California Division of the State Architect Interpretation of Regulations Manual.

END OF DOCUMENT

TESTING LABORATORY SERVICES**1. GENERAL****1.1. REFERENCES**

- 1.1.1. ASTM D3740 - Practice for Evaluation of Agencies Engaged in Testing and/or Inspection of Soil and Rock as Used in Engineering Design and Construction.
- 1.1.2. ASTM E329 - Recommended Practice for Inspection and Testing Agencies for Concrete, Steel, and Bituminous Materials as Used in Construction.
- 1.1.3. CBC - California Building Code.
- 1.1.4. IBL – International Building Code.
- 1.1.5. Title 24, Parts 1 and 2, of the California Code of Regulations. Developer shall keep a copy of these available at the job Site for ready reference during construction
- 1.1.6. DSA - Division of the State Architect, Office of Regulation Services, Structural Safety Section. DSA shall be notified at or before the start of construction.

1.2. OBSERVATION AND SUPERVISION

- 1.2.1. The District and Construction Manager or their appointed representatives will review the Work and the Developer shall provide facilities and access to the Work at all times as required to facilitate this review. Administration by the Architect and any consulting Structural Engineer will be in accordance with applicable regulations, including, without limitation, 24 C.C.R. §4-341.
- 1.2.2. One or more Project Inspector(s) approved by DSA and employed by or in contract with the District("Project Inspector"), will observe the Work in accordance with 24 C.C.R. §§4-333(b) and 4-342:
- 1.2.3. Project Inspector shall have access to the Work wherever it is in preparation or progress for ascertaining that the Work is in accordance with the Contract Documents and all applicable code sections. Developer shall provide facilities and access as required and shall provide assistance for sampling or measuring materials.
 - 1.2.3.1. Project Inspector will notify District and Architect and inform Developer of any observed failure of Work or material to conform to Contract Documents.
 - 1.2.3.2. The Project Inspector shall observe and monitor all testing and inspection activities required.
- 1.2.4. Developer shall conform with all applicable laws as indicated in the Contract Documents, including, without limitation, to 24 C.C.R. §4-343. Developer shall supervise and direct the Work and maintain a competent superintendent on the Project who is authorized to act in all matters pertaining to the Work. The Developer shall inspect all materials, as they arrive, for compliance with the Contract Documents. Developer shall reject defective Work or materials immediately upon delivery or failure of the Work or material to comply with the Contract Documents. The Developer shall submit verified reports as indicated in the Contract Documents, including, without limitation, the Specifications and as required by 24 C.C.R. §4-336.

1.3. TESTING LABORATORIES AND AGENCIES

- 1.3.1. Testing agencies and tests shall be in conformance with the Contract Documents and the requirements of 24 C.C.R. §4-335.
- 1.3.2. Testing and inspection in connection with earthwork shall be under the direction of the District's consulting soils engineer ("Soils Engineer").
- 1.3.3. Testing and inspection of construction materials and workmanship shall be performed by a qualified laboratory ("Testing Laboratory" or "Laboratory"). The Testing Laboratory shall be under direction of an engineer registered in the State of California, shall conform to requirements of ASTM E329, and shall be employed by or in contract with the District.

1.4. TESTS AND INSPECTIONS

- 1.4.1. Developer shall be responsible for notifying District and Project Inspector of all required tests and inspections. Developer shall notify District and Project Inspector forty-eight (48) hours in advance of performing any Work requiring testing or inspection.

- 1.4.2. Developer shall provide access to Work to be tested and furnish incidental labor, equipment, and facilities to facilitate all inspections and tests.
- 1.4.3. District will pay for first inspections and tests required by the Title 24 and other inspections or tests that District and/or Architect may direct to have made, including, but not limited to, the following principal items:
 - 1.4.3.1. Tests and observations for earthwork and pavings.
 - 1.4.3.2. Tests for concrete mix designs, including tests of trial batches.
 - 1.4.3.3. Tests and inspections for structural steel work.
 - 1.4.3.4. Field tests for framing lumber moisture content.
 - 1.4.3.5. Additional tests directed by District that establish that materials and installation comply with the Contract Documents.
 - 1.4.3.6. Test and observation of welding and expansion anchors.
 - 1.4.3.7. Factory observation of components and assembly of modular prefabrication structures and buildings.
- 1.4.4. District may at its discretion, pay and back charge Developer for:
 - 1.4.4.1. Retests or reinspections, if required, and tests or inspection required due to Developer error or lack of required identifications of material.
 - 1.4.4.2. Uncovering of work in accordance with Contract Documents.
 - 1.4.4.3. Testing done on weekends, holidays, and overtime will be chargeable to Developer for the overtime portion.
 - 1.4.4.4. Testing done off site.
- 1.4.5. Testing and inspection reports and certifications:
 - 1.4.5.1. If initially received by Developer, Developer shall provide to each of the following a copy of the agency or laboratory report of each test or inspection or certification: District; Construction Manager, if any; Architect; Consulting Engineer, if any; Other Engineers on the Project, as appropriate; and; Project Inspector.
 - 1.4.5.2. When the test or inspection is one required by the Title 24, a copy of the report shall also be provided to the DSA.
- 1.5. SELECTION AND PAYMENT**
 - 1.5.1. District will hire and pay for services of an independent Testing Laboratory to perform specified inspection and testing as specified by District's Testing Laboratory.
 - 1.5.2. District's hiring of Testing Laboratory shall in no way relieve Developer of its obligation to perform work in accordance with requirements of Contract Documents.
- 1.6. DISTRICT'S TESTING LABORATORY RESPONSIBILITIES**
 - 1.6.1. Test samples of mixes submitted by Inspector.
 - 1.6.2. Perform specified inspection, sampling, and testing of Products in accordance with specified standards.
 - 1.6.3. Notify Architect and Developer of observed irregularities or non-conformance of Work or Products.
 - 1.6.4. Attend preconstruction conferences and progress meetings when requested by Architect.
- 1.7. LABORATORY REPORTS**
 - 1.7.1. After each inspection and test, District shall then submit one copy of laboratory report to Developer Reports of test results of materials and inspections found not to be in compliance with the requirements of the Contract Documents shall be forwarded immediately.
 - 1.7.2. Each Testing Laboratory shall submit a verified report covering all of the tests which were required to be made by that agency during the progress of the Project. Such report shall be furnished each time that Work is suspended, covering the tests up to that time and at the Completion of the Project, covering all tests.
- 1.8. LIMITS ON TESTING LABORATORY AUTHORITY**
 - 1.8.1. Laboratory may not release, revoke, alter, or enlarge on requirements of Contract Documents.
 - 1.8.2. Laboratory may not approve or accept any portion of the Work.

1.8.3. Laboratory may not assume any duties of Developer

1.8.4. Laboratory has no authority to stop the Work.

1.9. CONTRACTOR RESPONSIBILITIES

1.9.1. Submit proposed items for testing as required herein and/or as further required in the Contract Documents to Architect for review in accordance with applicable specifications.

1.9.2. Cooperate with Laboratory personnel, and provide access to the Work and to manufacturer's facilities.

1.9.3. Notify Architect, District, and Testing Laboratory 48 hours prior to expected time for operations requiring inspection and testing services.

1.9.4. When tests or inspections cannot be performed after such notice, reimburse District for Laboratory personnel and travel expenses incurred due to the Developer's negligence.

1.9.5. Developer shall notify District a sufficient time in advance of the manufacture of material to be supplied by Developer pursuant to the Contract Documents, which must by terms of the Contract be tested, in order that the District may arrange for the testing of same at the source of supply.

1.9.5.1. Any material shipped by the Developer from the source of supply prior to having satisfactorily passed such testing and inspection or prior to the receipt of notice that such testing and inspection will not be required shall not be incorporated in the Work.

1.9.6. Contract and pay for services of District's Testing Laboratory to perform additional inspections, sampling and testing required when initial tests indicate Developer's work and/or materials does not comply with Contract Documents.

1.10. SCHEDULE OF INSPECTIONS AND TESTS

The Testing Laboratory shall perform tests and inspections for the following in conformance with the (CBC) California Building Code (International Building Code with State of California Amendments), California Code of Regulations, Title 24, Part 2:

- Structural Tests and Special Inspections (Chapter 17A)
 - Special Inspections (§ 1704A)
- Soils and Foundations (Chapter 18A)
 - Geotechnical Investigations (§ 1803A)
- Concrete (Chapter 19A)
 - Specifications for Tests and Materials (§)
 - Concrete Quality, Mixing and Placing (§)
 - Concrete Reinforcement and Anchor Testing Inspection (§ 1916A)
- Masonry (Chapter 21A)
 - Masonry Construction Materials (§ 2103A)
 - Masonry Quality (§ 2103A)
 - Quality Assurance (§ 2105A)
- Structural Steel (Chapter 22A)
 - Structural Steel (§ 2205A)
 - Identification & Protection of Steel for Structural Purposes (§ 2203A)
 - Inspection and Tests of Structural Steel (§ 2212A)
- Wood (Chapter 23)
 - Minimum Standards and Quality (§ 2303)
 - Wood Construction (§ 1704A.6)
- Exterior Walls (Chapter 14)
 - Masonry Units (§ 1404.4)
 - Masonry Construction Materials (§ 2103A)
 - Exterior Insulation and Finish Systems (§ 1408)
- Roof Assemblies and Roofing Structures (Chapter 15)
 - Materials (§ 1506)
- Aluminum (Chapter 20)
 - Materials (§ 2002.1)
 - Inspection (§ 2003.1)

- 1.10.1. **Plumbing**
Testing as specified in the Specifications including, but not limited to: Sterilization, soil waste and vent, water piping, source of water, gas piping, downspouts and storm drains.
- 1.10.2. **Automatic Fire Sprinklers (where applicable)**
Testing as specified in the Specifications including, but not limited to: hydrostatic pressure.
- 1.10.3. **Heating, Ventilating and Air Conditioning:**
Testing as specified in the Specifications including, but not limited to: Ductwork tests, cooling tower tests, boiler tests, controls testing, piping tests, water and air systems, and test and balance of heating and air conditioning systems.
- 1.10.4. **Electrical**
Testing as specified in the Specifications including, but not limited to: Equipment testing, all electrical system operations, grounding system and checking insulation after cable is pulled.
- 1.11. **PROJECT INSPECTOR'S ACCESS TO SITE**
 - 1.11.1. A Project Inspector employed by the District in accordance with the requirement of State of California Code of Regulations, Title 24, Part 1 will be assigned to the Work. Project Inspector's duties are specifically defined in 24. C.C.R. §4-342, and as indicated in the General Construction Provisions (Exhibit "D" to the Facilities Lease).
 - 1.11.2. District and Construction Manager shall at all times have access for the purpose of inspection to all parts of the Work and to the shops wherein the Work is in preparation, and Developer shall at all times maintain proper facilities and provide safe access for such inspection.
 - 1.11.3. The Work in all stages of progress shall be subject to the personal continuous observation of the Inspector. Inspector shall have free access to any or all parts of the Work at any time. Developer shall furnish the Inspector reasonable facilities for obtaining such information as may be necessary to keep Inspector fully informed respecting the progress and manner of the Work and the character of the materials. Inspection of the Work shall not relieve the Developer from any obligation set forth in the Contract Documents.
 - 1.11.4. The Inspector is not authorized to change, revoke, alter, enlarge or decrease in any way any requirement of the Contract Documents, drawings, specifications or subsequent change orders.
 - 1.11.5. Whenever there is insufficient evidence of compliance with any of the provisions of Title 24 or evidence that any material or construction does not conform to the requirements of Title 24, the Division of the State Architect may require tests as proof of compliance. Test methods shall be as specified herein or by other recognized and accepted test methods determined by the Division of the State Architect. All tests shall be performed by a testing laboratory accepted by the Division of the State Architect.

END OF DOCUMENT

TEMPORARY FACILITIES AND CONTROLS**1. GENERAL****1.1. LOGISTICS PLAN**

Developer shall provide to the District for prior approval the Developer's mobilization and logistics plan for the Site which shall include, at a minimum, the provisions herein.

1.2. TEMPORARY UTILITIES**1.2.1. Electric Power and Lighting**

1.2.1.1. Developer will furnish and pay for power during the course of the work to the extent power is not in the building(s) or on the Site. Developer shall be responsible for providing temporary facilities required on the Site to point of intended use.

1.2.1.2. Developer shall furnish, wire for, install, and maintain temporary electrical lights wherever it is necessary to provide illumination for the proper performance and/or observation of the Work: a minimum of 20 foot-candles for rough work and 50 foot-candles for finish work.

1.2.1.3. Developer shall be responsible for maintaining existing lighting levels in the Project vicinity should temporary outages or service interruptions occur.

1.2.2. Heat and Ventilation

1.2.2.1. Developer shall provide temporary heat to maintain environmental conditions to facilitate progress of the Work, to meet specified minimum conditions for the installation and curing of materials, and to protect materials and finishes from damage due to improper temperature and humidity conditions. Portable heaters shall be standard units complete with controls.

1.2.2.2. Developer shall provide forced ventilation and dehumidification, as required, of enclosed areas for proper installation and curing of materials, to disperse humidity, and to prevent accumulations of dust, fumes, vapors, and gases.

1.2.2.3. Developer shall pay the costs of installation, maintenance, operation, and removal of temporary heat and ventilation, including costs for fuel consumed, required for the performance of the Work.

1.2.3. Water

1.2.3.1. Developer will furnish and pay for water during the course of the work. Developer shall be responsible for providing temporary facilities required.

1.2.3.2. Developer shall make potable water available for human consumption.

1.2.4. Sanitary Facilities

1.2.4.1. Developer shall provide sanitary temporary facilities in no fewer numbers than required by law and such additional facilities as may be directed by the Inspector for the use of all workers. The facilities shall be maintained in a sanitary condition at all times and shall be left at the Site until removal is directed by the Project Inspector or Developer completes all Work.

1.2.4.2. Use of toilet facilities in the Work shall not be permitted except by consent of the Project Inspector and District.

1.2.5. Telephone and Internet Service

1.2.5.1. Developer shall arrange with local telephone and internet service company(ies) for service for the performance of the Work. Developer shall, at a minimum, provide in its field office one line for telephone, internet and one line for fax machine.

1.2.5.2. Developer shall pay the costs for internet, telephone, and fax lines installation, maintenance, service, and removal; for Construction Site Office, Construction Manager's Office and Inspector's Office.

1.2.6. Fire Protection:

1.2.6.1. Developer shall provide and maintain fire extinguishers and other equipment for fire protection. Such equipment shall be designated for use for fire protection only and shall comply with all requirements of the California Fire,

State Fire Marshall and/or its designee.

- 1.2.6.2. Where on-site welding and burning of steel is unavoidable, Developer shall provide protection for adjacent surfaces.

1.2.7. Trash Removal:

Developer shall provide trash removal on a timely basis, not less than weekly from all Site Offices and the Site.

1.2.8. Temporary Facilities:

- 1.2.8.1. Developer shall provide the following facilities, trailers, offices, and services, fully furnished for the intended uses including desks, chairs, plan tables, etc.:

1.2.8.1.1. NONE

1.3. CONSTRUCTION AIDS

1.3.1. Plant and Equipment:

1.3.1.1. Developer shall furnish, operate, and maintain a complete plant for fabricating, handling, conveying, installing, and erecting materials and equipment; and for conveyances for transporting workmen. Include elevators, hoists, debris chutes, and other equipment, tools, and appliances necessary for performance of the Work.

1.3.1.2. Developer shall maintain plant and equipment in safe and efficient operating condition. Damages due to defective plant and equipment, and uses made thereof, shall be repaired by Developer at no expense to the District.

- 1.3.2. No District tools or equipment shall be used by Developer for the performance of the Work.

1.4. BARRIERS AND ENCLOSURES

1.4.1. Developer shall obtain District's written permission for locations and types of temporary barriers and enclosures, including fire-rated materials proposed for use, prior to their installation.

1.4.2. Developer shall provide a six (6) foot high, chain link perimeter fence with post driven into the ground and fabric screen as a temporary barrier around construction area. Developer shall provide and maintain temporary enclosures to prevent public entry and to protect persons using other buildings and portions of the Site and/or Premises. Developer shall remove temporary fence, barriers and enclosure upon Completion of the Work.

1.4.3. Developer shall provide site access to existing facilities for persons using other buildings and portions of the Site, the public, and for deliveries and other services and activities.

1.5. SECURITY

1.5.1. Developer shall secure all construction equipment, machinery and vehicles, park and store only within fenced area, and render inoperable during non-work hours. Developer is responsible for insuring that no construction materials, tools, equipment, machinery or vehicles can be used for unauthorized entry or other damage or interference to activities and security of existing facilities adjacent to and in the vicinity of the Project Site.

1.5.2. Developer shall provide a security guard located on the Project Site during non-working hours.

1.6. TEMPORARY CONTROLS

1.6.1. Noise Control

1.6.1.1. Developer acknowledges that adjacent facilities may remain in operation during all or a portion of the Work, and it shall take all reasonable precautions to minimize noise as required by applicable laws and the Contract Documents.

1.6.1.2. Notice of proposed noisy operations, including without limitation, operation of pneumatic demolition tools, concrete saws, and other equipment, shall be submitted to District a minimum of forty-eight (48) hours in advance of their performance.

1.6.2. Noise and Vibration

1.6.2.1. Equipment and impact tools shall have intake and exhaust mufflers.

1.6.2.2. Developer shall cooperate with District to minimize and/or cease the use of

noisy and vibratory equipment if that equipment becomes objectionable by its longevity.

1.6.3. Dust and Dirt

- 1.6.3.1. Developer shall conduct demolition and construction operations to minimize the generation of dust and dirt, and prevent dust and dirt from interfering with the progress of the Work and from accumulating in the Work and adjacent areas including, without limitation, occupied facilities.
- 1.6.3.2. Developer shall periodically water exterior demolition and construction areas to minimize the generation of dust and dirt.
- 1.6.3.3. Developer shall ensure that all hauling equipment and trucks carrying loads of soil and debris shall have their loads sprayed with water or covered with tarpaulins, and as otherwise required by local and state ordinance.
- 1.6.3.4. Developer shall prevent dust and dirt from accumulating on walks, roadways, parking areas, and planting, and from washing into sewer and storm drain lines.

1.6.4. Water

Developer shall not permit surface and subsurface water, and other liquids, to accumulate in or about the vicinity of the Premises. Should accumulation develop, Developer shall control the water or other liquid, and suitably dispose of it by means of temporary pumps, piping, drainage lines, troughs, ditches, dams, or other methods.

1.6.5. Pollution

- 1.6.5.1. No burning of refuse, debris, or other materials shall be permitted on or in the vicinity of the Premises.
- 1.6.5.2. Developer shall comply with applicable regulatory requirements and anti-pollution ordinances during the conduct of the Work including, without limitation, demolition, construction, and disposal operations.

1.6.6. Lighting

If portable lights are used after dark, all light must be located so as not to direct light into neighboring property.

1.7. JOB SIGN(S)

1.7.1. General:

- 1.7.1.1. Developer shall provide and maintain and locate a Project identification sign with the design, text, and colors designated by District and/or the Architect. Sign shall be protected in place and maintained by the Developer.
- 1.7.1.2. Signs other than the specified Project sign and or signs required by law, for safety, or for egress, shall not be permitted, unless otherwise approved in advance by the District.

1.7.2. Materials:

- 1.7.2.1. Structure and Framing: Structurally sound, new or used wood or metal; wood shall be nominal 3/4-inch exterior grade plywood.
- 1.7.2.2. Sign Surface: Minimum 3/4-inch exterior grade plywood.
- 1.7.2.3. Sign shall be mounted on 4"x4" wooden posts embedded at least thirty six (36) inches into the soil or placed in concrete.
- 1.7.2.4. Paint: Exterior quality, of type and colors selected by the District and/or the Architect.

1.7.3. Fabrication:

- 1.7.3.1. Developer shall fabricate to provide smooth, even surface for painting.
- 1.7.3.2. Size: 4'-0" x 8'-0", unless otherwise indicated.
- 1.7.3.3. Developer shall paint exposed surfaces of supports, framing, and surface material with exterior grade paint: one coat of primer and one coat of finish paint.
- 1.7.3.4. Text and Graphics: As indicated.

1.8. PUBLICITY RELEASES

Developer shall not release any information, story, photograph, plan, or drawing relating information about the Project to anyone, including press and other public communications medium, including, without limitation, on website(s). Developer shall not bring anyone onto the project site during or after

construction for the purpose of publicity or marketing without prior written permission of the District.

END OF DOCUMENT

SITE STANDARDS**1. GENERAL****1.1. REQUIREMENTS OF THE DISTRICT****1.1.1. Drug-Free Schools and Safety Requirements:**

- 1.1.1.1. No drugs, alcohol, smoking or the use of tobacco products are allowed at any time in any buildings, Developer-owned vehicles or vehicles owned by others while on District property. No students, staff, visitors, or contractors are to use drugs on these sites.
- 1.1.1.2. Developer shall post: "Non-Smoking Area" in a highly visible location on Site. Developer may designate a smoking area outside of District property within the public right-of-way, provided that this area remains quiet and unobtrusive to adjacent neighbors. This smoking area must be kept clean at all times.
- 1.1.1.3. Developer shall ensure that no alcohol, firearms, weapons, or controlled substances enter or are used at the Site. Developer shall immediately remove from the Site and terminate the employment of any employee(s) found in violation of this provision.

1.1.2. **Language:** Unacceptable and/or loud language will not be tolerated, "Cat calls" or other derogatory language toward students or public will not be allowed.

1.1.3. Disturbing the Peace (Noise and Lighting):

- 1.1.3.1. Developer shall observe the noise ordinance of the Site at all times including, without limitation, all applicable local, city, and/or state laws, ordinances, and/or regulations regarding noise and allowable noise levels.
- 1.1.3.2. District reserves the right to prohibit the use of radios at the Site, except for handheld communication radios.
- 1.1.3.3. If portable lights are used after dark, the lights must be located so as not to direct light into neighboring properties.

1.1.4. Traffic:

- 1.1.4.1. Driving on the Premises shall be limited to periods when students and public are not present. If driving or deliveries must be made during the school hours, two (2) or more ground guides shall lead the vehicle across the area of travel. In no case shall driving take place across playgrounds or other pedestrian paths during recess, lunch, and/or class period changes. The speed limit on-the Premises shall be five (5) miles per hour (maximum) or less if conditions require. Developer shall not have any deliveries to the Project during the hour before school begins at the Site and during the half hour after school ends at the Site without prior written permission from the Construction Manager or the District.
- 1.1.4.2. All paths of travel for deliveries, including without limitation, material, equipment, and supply deliveries, shall be reviewed and approved by District in advance.
- 1.1.4.3. District shall designate a construction entry to the Site. If Developer requests, District determines it is required, and to the extent possible, District shall designate a staging area so as not to interfere with the normal functioning of school facilities. Location of gates and fencing shall be approved in advance with District and at Developer's expense.
- 1.1.4.4. Parking areas shall be reviewed and approved by District in advance. No parking is to occur under the drip line of trees or in areas that could otherwise be damaged.
- 1.1.4.5. All of the above shall be observed and complied with by the Developer and all workers on the Site. Failure to follow these directives could result in individual(s) being suspended or removed from the work force at the discretion of the District. The same rules and regulations shall apply equally to delivery personnel, inspectors, consultants, and other visitors to the Site.

END OF DOCUMENT

TEMPORARY TREE AND PLANT PROTECTION

WHERE SUBSTANTIAL TREE PROTECTION WILL BE REQUIRED ON THE SITE, OBTAIN AN ARBORIST TO REVIEW THIS DOCUMENT PRIOR TO CONSTRUCTION.

1. GENERAL**1.1. SUMMARY**

This Document includes the protection and trimming of existing trees that interfere with, or are affected by, execution of the Work, whether temporary or permanent construction.

1.2. DEFINITIONS

Tree Protection Zone: Area surrounding individual trees or groups of trees to remain during construction, and defined by the drip line of individual trees or the perimeter drip line of groups of trees, unless otherwise indicated.

1.3. SUBMITTALS

- 1.3.1. Product Data: For each type of product indicated.
- 1.3.2. Tree Pruning Schedule: Written schedule from arborist detailing scope and extent of pruning of trees to remain that interfere with or are affected by construction.
- 1.3.3. Qualification Data: For tree service firm and arborist.
- 1.3.4. Certification: From arborist, certifying that trees indicated to remain have been protected during construction according to recognized standards and that trees were promptly and properly treated and repaired when damaged.
- 1.3.5. Maintenance Recommendations: From arborist, for care and protection of trees affected by construction during and after completing the Work.

1.4. QUALITY ASSURANCE

- 1.4.1. Tree Service Firm Qualifications: An experienced tree service firm that has successfully completed tree protection and trimming work similar to that required for this Project and that will assign an experienced, qualified arborist to Project site during execution of tree protection and trimming.
- 1.4.2. Arborist Qualifications: An arborist certified by ISA (International Society of Arboriculture) or licensed in the jurisdiction where Project is located.
- 1.4.3. Tree Pruning Standard: Comply with ANSI A300 (Part 1), "Tree, Shrub, and Other Woody Plant Maintenance--Standard Practices (Pruning)."
 - 1.4.3.1. Before tree protection and trimming operations begin, meet with District to review tree protection and trimming procedures and responsibilities.

2. PRODUCTS**2.1. MATERIALS**

- 2.1.1. Drainage Fill: Selected crushed stone, or crushed or uncrushed gravel, washed, ASTM D 448, Size 24, with 90 to 100 percent passing a 2-1/2-inch (63-mm) sieve and not more than 10 percent passing a 3/4-inch (19-mm) sieve.
- 2.1.2. Topsoil: Natural or cultivated surface-soil layer containing organic matter and sand, silt, and clay particles; friable, pervious, and black or a darker shade of brown, gray, or red than underlying subsoil; reasonably free of subsoil, clay lumps, gravel, and other objects more than 1 inch (25 mm) in diameter; and free of weeds, roots, and toxic and other nonsoil materials.
 - 2.1.2.1. Obtain topsoil only from well-drained sites where topsoil is 4 inches (100 mm) deep or more; do not obtain from bogs or marshes.
- 2.1.3. Filter Fabric: Manufacturer's standard, nonwoven, pervious, geotextile fabric of polypropylene, nylon, or polyester fibers.
- 2.1.4. Chain-Link Fence: Metallic-coated steel chain-link fence fabric of 0.120-inch- (3-mm-) diameter wire; a minimum of 48 inches (1200 mm) high; with 1.9-inch- (48-mm-) diameter line posts; 2-3/8-inch- (60-mm-) diameter terminal and corner posts; 1-5/8-inch- (41-mm-) diameter top rail; and 0.177-inch- (4.5-mm-) diameter bottom tension wire; with tie wires, hog ring ties, and other accessories for a complete fence system.
- 2.1.5. Select mulch as recommended by arborist or landscape architect.

- 2.1.6. Organic Mulch: Use shredded hardwood, ground or shredded bark, or wood and bark chips, all free of deleterious materials.

3. EXECUTION

3.1. PREPARATION

- 3.1.1. Temporary Fencing: Install temporary fencing around tree protection zones to protect remaining trees and vegetation from construction damage. Maintain temporary fence and remove when construction is complete.
- 3.1.2. Install chain-link fence according to ASTM F 567 and manufacturer's written instructions.
- 3.1.3. Protect tree root systems from damage caused by runoff or spillage of noxious materials while mixing, placing, or storing construction materials. Protect root systems from ponding, eroding, or excessive wetting caused by dewatering operations.
- 3.1.4. Mulch areas inside tree protection zones and other areas indicated.
- 3.1.4.1. Select mulch as recommended by arborist or landscape architect.
- 3.1.4.2. Apply 2-inch (50-mm) to 3-inch (75-mm) average thickness of organic mulch. Do not place mulch within 6 inches (150 mm)] of tree trunks.
- 3.1.5. Do not store construction materials, debris, or excavated material inside tree protection zones. Do not permit vehicles or foot traffic within tree protection zones; prevent soil compaction over root systems.
- 3.1.6. Maintain tree protection zones free of weeds and trash.
- 3.1.7. Do not allow fires within tree protection zones.

3.2. EXCAVATION

- 3.2.1. Install shoring or other protective support systems to minimize sloping or benching of excavations where construction or utility excavation is near trees to be protected.
- 3.2.2. Do not excavate within tree protection zones, unless otherwise indicated.
- 3.2.3. Where excavation for new construction is required within tree protection zones, hand clear and excavate to minimize damage to root systems. Use narrow-tine spading forks and comb soil to expose roots.
- 3.2.3.1. Do not allow exposed roots to dry out before placing permanent backfill. Provide temporary earth cover or pack with peat moss and wrap with burlap. Water and maintain in a moist condition. Temporarily support and protect roots from damage until they are permanently relocated and covered with soil.
- 3.2.4. Where utility trenches are required within tree protection zones, tunnel under or around roots by drilling, auger boring, pipe jacking, or digging by hand.
- 3.2.4.1. Root Pruning: Do not cut main lateral roots or taproots; cut only smaller roots that interfere with installation of utilities. Cut roots with sharp pruning instruments; do not break or chop.

3.3. REGRADING

- 3.3.1. Grade Lowering: Where new finish grade is indicated below existing grade around trees, slope grade beyond tree protection zones. Maintain existing grades within tree protection zones.
- 3.3.2. Grade Lowering: Where new finish grade is indicated below existing grade around trees, slope grade away from trees as recommended by arborist, unless otherwise indicated.
- 3.3.2.1. Root Pruning: Prune tree roots exposed during grade lowering. Do not cut main lateral roots or taproots; cut only smaller roots. Cut roots with sharp pruning instruments; do not break or chop.
- 3.3.3. Minor Fill: Where existing grade is 6 inches (150 mm) or less below elevation of finish grade, fill with topsoil. Place topsoil in a single uncompacted layer and hand grade to required finish elevations.
- 3.3.4. Moderate Fill: Where existing grade is more than 6 inches (150 mm) but less than 12 inches (300 mm) below elevation of finish grade, place drainage fill, filter fabric, and topsoil on existing grade as follows:
- 3.3.4.1. Carefully place drainage fill against tree trunk approximately 2 inches (50 mm) above elevation of finish grade and extend not less than 18 inches (450 mm)

from tree trunk on all sides. For balance of area within drip-line perimeter, place drainage fill up to 6 inches (150 mm) below elevation of grade.

3.3.4.2. Place filter fabric with edges overlapping 6 inches (150 mm) minimum.

3.3.4.3. Place fill layer of topsoil to finish grade. Do not compact drainage fill or topsoil. Hand grade to required finish elevations.

3.4. TREE PRUNING

3.4.1. Prune trees to remain that are affected by temporary and permanent construction.

3.4.2. Prune trees to remain to compensate for root loss caused by damaging or cutting root system. Provide subsequent maintenance during Contract period as recommended by arborist.

3.4.3. Pruning Standards: Prune trees according to ANSI A300 (Part 1), as recommended by arborist report.

3.4.4. Adjust pruning requirements per arborist's recommendations.

3.4.5. Cut branches with sharp pruning instruments; do not break or chop.

3.4.6. Modify below to specific project requirements.

3.4.7. Chip removed tree branches and dispose of or spread over areas identified by District.

3.5. TREE REPAIR AND REPLACEMENT

3.5.1. Promptly repair trees damaged by construction operations within 24 hours. Treat damaged trunks, limbs, and roots according to arborist's written instructions.

3.5.2. Remove and replace trees indicated to remain that die or are damaged during construction operations or that are incapable of restoring to normal growth pattern.

3.5.2.1. Provide new trees of 6-inch (150-mm) caliper size and of a when damaged trees more than 6 inches (150 mm) in caliper size, measured 12 inches (300 mm) above grade, are required to be replaced. Plant and maintain new trees as specified in Contract Documents.

3.5.3. Where recommended by arborist report, aerate surface soil, compacted during construction, 10 feet (3 m) beyond drip line and no closer than 36 inches (900 mm) to tree trunk. Drill 2-inch (50-mm) diameter holes a minimum of 12 inches (300 mm) deep at 24 inches (600 mm) o.c. Backfill holes with an equal mix of augered soil and sand.

3.6. DISPOSAL OF WASTE MATERIALS

3.6.1. Burning is not permitted.

3.6.2. Disposal: Remove excess excavated material and displaced trees from Site.

END OF DOCUMENT

STORM WATER POLLUTION PREVENTION PLAN – CONSTRUCTION

PURSUANT TO THE PROVISIONS OF EXHIBIT “D” AND THE CONTRACT DOCUMENTS, DEVELOPER SHALL PERFORM THE WORK OF THE PROJECT RELATED TO BEING THE DISTRICT’S QUALIFIED SWPPP (STORM WATER POLLUTION PREVENTION PLAN) PRACTITIONER (“QSP”). THE DEVELOPER SHALL COMPLY WITH THE FOLLOWING PROVISIONS AND THE SWPPP. IF THE SWPPP CONTAINS OTHER MORE DETAILED OR CONFLICTING PROVISIONS AND/OR REQUIRES THE DEVELOPER TO TAKE OTHER ACTIONS OR ACTIVITIES, THE DEVELOPER MUST COMPLY WITH THE SWPPP.

1. INTRODUCTION

- 1.1. In order to enroll in the construction storm water permit and before construction activities begin, the District will file certain submittals referred to as Permit Registration Documents (PRDS) with the Regional Water Quality Control Board.

2. GENERAL

The Clean Water Act and Porter Cologne Water Quality Act prohibit the discharge of any water containing pollutants from certain construction sites unless a National Pollutant Discharge Elimination System permit is first obtained and followed. The National Pollutant Discharge Elimination System General Permit for Storm Water Discharges Associated with Construction and Land Disturbance Activities (Construction Storm Water Permit) Order No. 2009-0009-DWQ as amended by Order No. 2010-0014-DWQ (NPDES No. CAS000002) issued by the California State Water Resources Control Board (State Water Board) authorizes the discharge of storm water and certain non-storm water from construction sites if certain conditions and measures are taken. The District has determined that the construction of this Project requires enrollment in the Construction Storm Water Permit.

3. SUBMITTALS**3.1. GENERAL**

All submittals shall be made in a form conducive for the District to electronically upload the approved submittals to the Storm water Multi-Application Reporting and Tracking System (SMARTS).

3.2. RAIN EVENT ACTION PLAN (REAP)

- 3.2.1. A Rain Event Action Plan (REAP) is a written document, specific for each rain event. A REAP should be designed that when implemented it protects all exposed portions of the site within 48 hours of any likely. The General Permit requires Risk Level 2 and 3 dischargers to develop and implement a REAP designed to protect all exposed portions of their sites within 48 hours prior to any likely precipitation event. The REAP requirement is designed to ensure that the discharger has adequate materials, staff, and time to implement erosion and sediment control measures that are intended to reduce the amount of sediment and other pollutants generated from the active site. A REAP must be developed when there is likely a forecast of 50% or greater probability of precipitation in the project area. (The National Oceanic and Atmospheric Administration (NOAA) defines a chance of precipitation as a probability of precipitation of 30% to 50% chance of producing precipitation in the project area.¹⁴ NOAA defines the probability of precipitation (PoP) as the likelihood of occurrence (expressed as a percent) of a measurable amount (0.01 inch or more) of liquid precipitation (or the water equivalent of frozen precipitation) during a specified period of time at any given point in the forecast area.) Forecasts are normally issued for 12- hour time periods.
- 3.2.2. If the District’s QSD determines that the site is a Risk Level 2 or 3 the Developer’s QSP shall prepare the REAP for the Work in compliance with the General Permit and the SWPPP.

3.3. RECORDS

All electronic and hardcopy records required by the Construction Storm Water Permit shall be submitted to the District within seven (7) days of Completion of the Project.

4. PERMIT REGISTRATION DOCUMENTS

Prior to any activities on Site that disturb the Site’s surface, the Permit Registration Documents (PRDs) required by the Construction Storm Water Permit must be filed with the Regional Water Quality Control Board. The District shall file the PRDs with the Regional Water Quality Control Board to activate coverage under the Construction Storm Water Permit.

5. IMPLEMENTATION REQUIREMENTS

- 5.1. Developer shall not conduct any activities that may affect the Site's construction runoff water quality until the District provides Developer with the Waste Discharger Identification Number (WDID) assigned to this Project by the State Water Board.
- 5.2. Developer shall keep a copy of the approved SWPPP at the job site. The SWPPP shall be made available when requested by a representative of the Regional Water Quality Control Board, State Water Resources Control Board, United States Environmental Protection Agency, or the local storm water management agency. Requests from the public shall be directed to the District for response.
- 5.3. Developer shall designate in writing to the District a Qualified SWPPP Practitioner (QSP) who shall be responsible for implementing the SWPPP, REAP (if applicable), ATS (if applicable), conducting non-storm water and storm water visual observations, and for ensuring that all best management practices (BMPs) required by the SWPPP and General Permit are properly implemented and maintained.
- 5.4. All measures required by the SWPPP shall be implemented concurrent with the commencement of construction. Pollution practices and devices shall be followed or installed as early in the construction schedule as possible with frequent upgrading of devices as construction progresses.
- 5.5. Developer shall ensure that all measures are properly maintained and repaired to protect the water quality of discharges.

6. INSPECTION, SAMPLING, ANALYSIS, AND RECORD KEEPING REQUIREMENTS

The Developer's QSP shall conduct all required visual observations, sampling, analysis, reporting, and record keeping required by the SWPPP and the Construction Storm Water Permit.

7. REPORTING REQUIREMENTS

Developer shall prepare and provide all the reports, which include, but are not limited to the Annual Report and any NEL Violation Reports or NAL Exceedance Reports, all of which are required by the SWPPP and the Construction Storm Water Permit.

8. ANNUAL REPORT

By August 1 of each year (defined as July 1 to June 30) that had at least one continuous three (3) month period coverage under the General Permit, Developer shall complete and submit to the District an Annual Report, as required by the General Permit. If the Project is complete prior to August 1, Developer shall submit the report prior to acceptance of the Project.

9. COMPLETION OF WORK

- 9.1. Clean-up shall be performed as each portion of the work progresses. All refuse, excess material, and possible pollutants shall be disposed of in a legal manner off-site and all temporary and permanent SWPPP devices shall be in place and maintained in good condition.
- 9.2. At Completion of Work, Developer shall inspect installed SWPPP devices, and present the currently implemented SWPPP with all backup records to the District.

10. NOTICE OF TERMINATION (NOT)

A Notice of Termination (NOT) must be submitted by the Developer to the District for electronic submittal by the Legally Responsible Person via SMARTS to terminate coverage under the General Permit. The NOT must include a final Site Map and representative photographs of the Project site that demonstrate final stabilization has been achieved. The NOT shall be submitted to the District on or before the Developer submits its final application for payment. If the Regional Water Board rejects the NOT for any reason, the Developer shall revise the NOT as many times as necessary to get the Regional Water Board's approval. The Regional Water Board will consider a construction site complete when the conditions of the General Permit, Section II.D have been met.

11. QUALITY ASSURANCE

- 11.1. Before performing any of the obligations indicated herein, the Developer's QSP shall meet the training and certification requirements in the Construction Storm Water Permit.
- 11.2. Developer shall perform the Work in strict compliance with the approved SWPPP, REAP, ATS, and the Construction Storm Water Permit.
- 11.3. Developer shall conduct at least a one-hour training session on the requirements of the SWPPP for each employee before an employee conducts any construction on the Site. Developer shall maintain documentation of this employee training at the site for review by the District or any regulatory agency.

12. PERFORMANCE REQUIREMENTS

- 12.1. The Storm Water Pollution Prevention Plan is a minimum requirement. Revisions and modifications to the SWPPP are acceptable only if they maintain levels of protection equal to or greater than originally specified.
- 12.2. Read and be thoroughly familiar with all of the requirements of the SWPPP.
- 12.3. Inspect and monitor all work and storage areas for compliance with the SWPPP prior to any anticipated rain.
- 12.4. Complete any and all corrective measures as may be directed by the regulatory agency.
- 12.5. **Penalties:** Developer shall pay any fees and any penalties that may be imposed by the regulatory agency for non-compliance with SWPPP during the course of Work.
- 12.6. **Costs:** Developer to pay all costs associated with the implementation of the requirements of the SWPPP in order to maintain compliance with the Permit. This includes installation of all Housekeeping BMPs, General Site and Material Management BMPs, Inspection requirements, maintenance requirements, and all other requirements specified in the SWPPP.

13. **MATERIALS**

All temporary and permanent storm water pollution prevention facilities, equipment, and materials as required by or as necessary to comply with the SWPPP as described in the BMP Handbook.

END OF DOCUMENT

MATERIALS AND EQUIPMENT**1. GENERAL****1.1. MATERIAL AND EQUIPMENT**

- 1.1.1. Only items approved by the District and/or Architect shall be used.
- 1.1.2. Developer shall submit lists of Products and other Product information in accordance with the Contract Documents, including, without limitation, the provisions regarding the submittals.

1.2. MATERIAL AND EQUIPMENT COLORS

- 1.2.1. The Developer shall comply with all schedule(s) of colors provided by the District and/or Architect.
- 1.2.2. No individual color selections will be made until after approval of all pertinent materials and equipment and after receipt of appropriate samples in accordance with the Contract Documents, including, without limitation, the provisions regarding the submittals.
- 1.2.3. Developer shall request priority in writing for any item requiring advance ordering to maintain the approved Construction Schedule.

1.3. DELIVERY, STORAGE, AND HANDLING

- 1.3.1. Developer shall deliver manufactured materials in original packages, containers, or bundles (with seals unbroken), bearing name or identification mark of manufacturer.
- 1.3.2. Developer shall deliver fabrications in as large assemblies as practicable; where specified as shop-primed or shop-finished, package or crate as required to preserve such priming or finish intact and free from abrasion.
- 1.3.3. Developer shall store materials in such a manner as necessary to properly protect them from damage. Materials or equipment damaged by handling, weather, dirt, or from any other cause will not be accepted.
- 1.3.4. Materials are not be acceptable that have been warehoused for long periods of time, stored or transported in improper environment, improperly packaged, inadequately labeled, poorly protected, excessively shipped, deviated from normal distribution pattern, or reassembled.
- 1.3.5. Developer shall store material so as to cause no obstructions of sidewalks, roadways, and underground services. Developer shall protect material and equipment furnished pursuant to the Contract Documents.
- 1.3.6. Developer may store materials on Site with prior written approval by the District, all material shall remain under Developer's control and Developer shall remain liable for any damage to the materials. Should the Project Site not have storage area available, the Developer shall provide for off-site storage at no cost to District.
- 1.3.7. When any room in Project is used as a shop or storeroom, the Developer shall be responsible for any repairs, patching, or cleaning necessary due to that use. Location of storage space shall be subject to prior written approval by District.

2. PRODUCTS**2.1. MANUFACTURERS**

- 2.1.1. Manufacturers listed in various sections of Contract Documents are names of those manufacturers that are believed to be capable of supplying one or more of items specified therein.
- 2.1.2. The listing of a manufacturer does not imply that every product of that manufacturer is acceptable as meeting the requirements of the Contract Documents.

2.2. FACILITIES AND EQUIPMENT

Developer shall provide, install, maintain, and operate a complete and adequate facility for handling, the execution, disposal, and distribution of material and equipment as required for proper and timely performance of Work.

2.3. MATERIAL REFERENCE STANDARDS

Where material is specified solely by reference to "standard specifications" and if requested by District, Developer shall submit for review data on actual material proposed to be incorporated into Work, listing

name and address of vendor, manufacturer, or producer, and trade or brand names of those materials, and data substantiating compliance with standard specifications.

3. EXECUTION

3.1. WORKMANSHIP

- 3.1.1. Where not more specifically described in any other Contract Documents, workmanship shall conform to methods and operations of best standards and accepted practices of trade or trades involved and shall include items of fabrication, construction, or installation regularly furnished or required for completion (including finish and for successful operation, as intended).
- 3.1.2. Work shall be executed by tradespersons skilled in their respective field of work. When completed, parts shall have been durably and substantially built and present a neat appearance.

3.2. COORDINATION

- 3.2.1. Developer shall coordinate installation of materials and equipment so as to not interfere with installation of other work. Adjustment or rework because of Developer's failure to coordinate will be at no additional cost to District.
- 3.2.2. Developer shall examine in-place materials and equipment for readiness, completeness, fitness to be concealed or to receive Work, and compliance with Contract Documents. Concealing or covering work constitutes acceptance of additional cost which will result should in-place materials and equipment be found unsuitable for receiving other work or otherwise deviating from the requirements of the Contract Documents.

3.3. COMPLETENESS

Developer shall provide all portions of the Work, unless clearly stated otherwise, installed complete and operational with all elements, accessories, anchorages, utility connections, etc., in manner to assure well-balanced performance, in accordance with manufacturer's recommendations and in accordance with Contract Documents. For example, electric water coolers require water, electricity, and drain services; roof drains require drain system; sinks fit within countertop, etc. Terms such as "installed complete," "operable condition," "for use intended," "connected to all utilities," "terminate with proper cap," "adequately anchored," "patch and refinish," "to match similar," should be assumed to apply in all cases, except where completeness of functional or operable condition is specifically stated as not required.

3.4. APPROVED INSTALLER OR APPLICATOR

Developer shall ensure that all installations are only performed by a manufacturer's approved installer or applicator.

3.5. MANUFACTURER'S RECOMMENDATIONS

All installations shall be in accordance with manufacturer's published recommendations and specific written directions of manufacturer's representative. Should Contract Documents differ from recommendations of manufacturer or directions of manufacturer's representative, Developer shall analyze differences, make recommendations to the District and the Architect in writing, and shall not proceed until interpretation or clarification has been issued by the District and/or the Architect.

END OF DOCUMENT

DELIVERY, STORAGE AND HANDLING

1. GENERAL

1.1. PRODUCTS

- 1.1.1. Products are as defined in the General Construction Provisions (Exhibit "D" to the Facilities Lease).
- 1.1.2. Developer shall not use and/or reuse materials and/or equipment removed from existing Premises, except as specifically permitted by the Contract Documents.
- 1.1.3. Developer shall provide interchangeable components of the same manufacturer, for similar components.

1.2. TRANSPORTATION AND HANDLING

- 1.2.1. Developer shall transport and handle Products in accordance with manufacturer's instructions.
- 1.2.2. Developer shall promptly inspect shipments to confirm that Products comply with Contract requirements, are of correct quantity, and are undamaged.
- 1.2.3. Developer shall provide equipment and personnel to properly handle Products to prevent soiling, disfigurement, or damage.

1.3. STORAGE AND PROTECTION

- 1.3.1. Developer shall store and protect Products in accordance with manufacturer's instructions, with seals and labels intact and legible. Developer shall store sensitive Products in weather-tight, climate controlled enclosures.
- 1.3.2. Developer shall place fabricated Products that are stored outside, on above-ground sloped supports.
- 1.3.3. Developer shall provide off-site storage and protection for Products when Site does not permit on-site storage or protection.
- 1.3.4. Developer shall cover Products subject to deterioration with impervious sheet covering and provide ventilation to avoid condensation.
- 1.3.5. Developer shall store loose granular materials on solid flat surfaces in a well-drained area and prevent mixing with foreign matter.
- 1.3.6. Developer shall provide equipment and personnel to store Products by methods to prevent soiling, disfigurement, or damage.
- 1.3.7. Developer shall arrange storage of Products to permit access for inspection and periodically inspect to assure Products are undamaged and are maintained under specified conditions.

END OF DOCUMENT

CONTRACT CLOSEOUT AND FINAL CLEANING**1. GENERAL****1.1. CLOSEOUT PROCEDURES**

Developer shall comply with all closeout provisions as indicated in the General Construction Provisions (Exhibit "D" to the Facilities Lease).

1.2. FINAL CLEANING

- 1.2.1. Developer shall execute final cleaning prior to final inspection.
- 1.2.2. Developer shall clean interior and exterior glass and surfaces exposed to view; remove temporary labels, tape, stains, and foreign substances, polish transparent and glossy surfaces, wax and polish new vinyl floor surfaces, vacuum carpeted and soft surfaces.
- 1.2.3. Developer shall clean equipment and fixtures to a sanitary condition.
- 1.2.4. Developer shall replace filters of operating equipment.
- 1.2.5. Developer shall clean debris from roofs, gutters, down spouts, and drainage systems.
- 1.2.6. Developer shall clean Site, sweep paved areas, and rake clean landscaped surfaces.
- 1.2.7. Developer shall remove waste and surplus materials, rubbish, and construction facilities from the Site.

1.3. ADJUSTING

Developer shall adjust operating products and equipment to ensure smooth and unhindered operation.

1.4. RECORD DOCUMENTS AND SHOP DRAWINGS

Developer shall legibly mark each item to record actual construction, including:

- 1.4.1. Measured depths of foundation in relation to finish floor datum.
- 1.4.2. Measured horizontal and vertical locations of underground utilities and appurtenances, referenced to permit surface improvements.
- 1.4.3. Measured locations of internal utilities and appurtenances concealed in construction, referenced to visible and accessible features of the Work.
- 1.4.4. Field changes of dimension and detail.
- 1.4.5. Details not on original Contract Drawings
- 1.4.6. Changes made by modification(s).
- 1.4.7. References to related Shop Drawings and modifications.
- 1.4.8. Developer will provide one set of Record Drawings to District in an electronic format and one set on paper.
- 1.4.9. Developer shall submit all required documents to District and/or Architect prior to or with its final Application for Payment.

1.5. INSTRUCTION OF DISTRICT PERSONNEL

- 1.5.1. Before final inspection, at agreed upon times, Developer shall instruct District's designated personnel in operation, adjustment, and maintenance of products, equipment, and systems.
- 1.5.2. For equipment requiring seasonal operation, Developer shall perform instructions for other seasons within six (6) months.
- 1.5.3. Developer shall use operation and maintenance manuals as basis for instruction. Developer shall review contents of manual with personnel in detail to explain all aspects of operation and maintenance.
- 1.5.4. Developer shall prepare and insert additional data in Operation and Maintenance Manual when need for such data becomes apparent during instruction.
- 1.5.5. Developer shall use operation and maintenance manuals as basis for instruction. Developer shall review contents of manual with personnel in detail to explain all aspects of operation and maintenance.
- 1.5.6. Developer shall be available for up to two (2) four-hour sessions of additional training of District personnel at any time within the first year of operation of the Site.

1.6. SPARE PARTS AND MAINTENANCE MATERIALS

- 1.6.1. Developer shall provide products, spare parts, maintenance, and extra materials in quantities specified in the Specifications and in Manufacturer's recommendations.
- 1.6.2. Developer shall provide District all required Operation and Maintenance Data.

END OF DOCUMENT

FIELD ENGINEERING

1. GENERAL

1.1. REQUIREMENTS INCLUDED

- 1.1.1. Developer shall provide and pay for field engineering services by a California-registered engineer, required for the Project, including, without limitations:
 - 1.1.1.1. Survey work required in execution of the Project.
 - 1.1.1.2. Civil or other professional engineering services specified, or required to execute Developer's construction methods.

1.2. QUALIFICATIONS OF SURVEYOR OR ENGINEERS

Developer shall only use a qualified licensed engineer or registered land surveyor, to whom District makes no objection.

1.3. SURVEY REFERENCE POINTS

- 1.3.1. Existing basic horizontal and vertical control points for the Project are those designated on the Drawings.
- 1.3.2. Developer shall locate and protect control points prior to starting Site Work and preserve all permanent reference points during construction. In addition Developer shall:
 - 1.3.2.1. Make no changes or relocation without prior written notice to District and Architect.
 - 1.3.2.2. Report to District and Construction Manager when any reference point is lost or destroyed, or requires relocation because of necessary changes in grades or locations.
 - 1.3.2.3. Require surveyor to replace Project control points based on original survey control that may be lost or destroyed.

1.4. RECORDS

Developer shall maintain a complete, accurate log of all control and survey work as it progresses.

1.5. SUBMITTALS

- 1.5.1. Developer shall submit name and address of Surveyor and Professional Engineer to District and Construct Manager prior to its/their work on the Project.
- 1.5.2. On request of District and Construction Manager, Developer shall submit documentation to verify accuracy of field engineering work, at no additional cost to the District.
- 1.5.3. Developer shall submit a certificate signed by registered engineer or surveyor certifying that elevations and locations of improvements are in conformance or nonconformance with Contract Documents.

2. EXECUTION

2.1. COMPLIANCE WITH LAWS

Developer is responsible for meeting all applicable codes, OSHA, safety and shoring requirements.

2.2. NONCONFORMING WORK

Developer is responsible for any re-surveying required by correction of nonconforming work.

END OF DOCUMENT

CUTTING AND PATCHING**1. GENERAL****1.1. CUTTING AND PATCHING**

- 1.1.1. Developer shall be responsible for all cutting, fitting, and patching, including associated excavation and backfill, required to complete the Work or to:
 - 1.1.1.1. Make several parts fit together properly.
 - 1.1.1.2. Uncover portions of Work to provide for installation of ill-timed Work.
 - 1.1.1.3. Remove and replace defective Work.
 - 1.1.1.4. Remove and replace Work not conforming to requirements of Contract Documents.
 - 1.1.1.5. Remove Samples of installed Work as specified for testing.
 - 1.1.1.6. Provide routine penetrations of non-structural surfaces for installation of piping and electrical conduit.
 - 1.1.1.7. Attaching new materials to existing remodeling areas – including painting (or other finishes) to match existing conditions.
- 1.1.2. In addition to Contract requirements, upon written instructions from District, Developer shall uncover Work to provide for observations of covered Work in accordance with the Contract Documents; remove samples of installed materials for testing as directed by District; and remove Work to provide for alteration of existing Work.
- 1.1.3. Developer shall not cut or alter Work, or any part of it, in such a way that endangers or compromises the integrity of the Work, the Project, or work of others.
- 1.1.4. Developer shall not cut and patch operating elements and safety related components in a manner that results in reducing their capacity to perform as intended or that results in increased maintenance or decreased operational life or safety. Operating elements include the following:
 - 1.1.4.1. Primary operational systems and equipment.
 - 1.1.4.2. Air or smoke barriers.
 - 1.1.4.3. Fire-suppression systems.
 - 1.1.4.4. Mechanical systems piping and ducts.
 - 1.1.4.5. Control systems.
 - 1.1.4.6. Communication systems.
 - 1.1.4.7. Conveying systems.
 - 1.1.4.8. Electrical wiring systems.
- 1.1.5. Developer shall not cut and patch miscellaneous elements or related components in a manner that could change their load-carrying capacity, that results in reducing capacity to perform as intended, or that results in increased maintenance or decreased operational life of safety. Miscellaneous elements include the following:
 - 1.1.5.1. Water, moisture or vapor barriers.
 - 1.1.5.2. Membranes and flashings.
 - 1.1.5.3. Exterior curtain-wall construction.
 - 1.1.5.4. Equipment supports.
 - 1.1.5.5. Piping, ductwork, vessels and equipment.
 - 1.1.5.6. Noise and vibration control elements and systems.
 - 1.1.5.7. Shoring, bracing and sheeting.

1.2. SUBMITTALS

- 1.2.1. Developer shall submit written notice to District pursuant to the applicable notice provisions of the Contract Documents, requesting consent to proceed with the cutting or alteration (Request) at least ten (10) days prior to any cutting or alterations that may affect the structural safety of Project, or work of others, including the following:
 - 1.2.1.1. The work of the District or other trades.
 - 1.2.1.2. Structural value or integrity of any element of Project.
 - 1.2.1.3. Integrity or effectiveness of weather-exposed or weather-resistant elements or systems.

- 1.2.1.4. Efficiency, operational life, maintenance or safety of operational elements.
- 1.2.1.5. Visual qualities of sight-exposed elements.
- 1.2.2. Contractor's Request shall also include:
 - 1.2.2.1. Identification of Project.
 - 1.2.2.2. Description of affected Work.
 - 1.2.2.3. Necessity for cutting, alteration, or excavations.
 - 1.2.2.4. Affects of Work on District, other trades, or structural or weatherproof integrity of Project.
 - 1.2.2.5. Description of proposed Work:
 - 1.2.2.5.1. Scope of cutting, patching, alteration, or excavation.
 - 1.2.2.5.2. Trades that will execute Work.
 - 1.2.2.5.3. Products proposed to be used.
 - 1.2.2.5.4. Extent of refinishing to be done.
 - 1.2.2.6. Alternates to cutting and patching.
 - 1.2.2.7. Cost proposal, when applicable.
 - 1.2.2.8. The scheduled date the Developer intends to perform the Work and the duration of time to complete the Work.
 - 1.2.2.9. Written permission of other trades whose Work will be affected.

1.3. QUALITY ASSURANCE

- 1.3.1. Developer shall ensure that cutting, fitting, and patching shall achieve security, strength, weather protection, appearance for aesthetic match, efficiency, operational life, maintenance, safety of operational elements, and the continuity of existing fire ratings.
- 1.3.2. Developer shall ensure that cutting, fitting, and patching shall successfully duplicate undisturbed adjacent profiles, materials, textures, finishes, colors, and that materials shall match existing construction. Where there is dispute as to whether duplication is successful or has been achieved to a reasonable degree, the District's decision shall be final.

1.4. PAYMENT FOR COSTS

- 1.4.1. Cost caused by ill-timed or defective Work or Work not conforming to Contract Documents, including costs for additional services of the District, its consultants, including but not limited to the Construction Manager, the Architect, the Project Inspector(s), Engineers, and Agents, will be paid by Developer and/or deducted from the Contract by the District.
- 1.4.2. District shall only pay for cost of Work if it is part of the original Contract Price or if a change has been made to the contract in compliance with the provisions of the General Construction Provisions (Exhibit "D" to the Facilities Lease). Cost of Work performed upon instructions from the District, other than defective or nonconforming Work, will be paid by District on approval of written Change Order. Developer shall provide written cost proposals prior to proceeding with cutting and patching.

2. PRODUCTS

2.1. MATERIALS

- 2.1.1. Developer shall provide for replacement and restoration of Work removed. Developer shall comply with the Contract Documents and with the Industry Standard(s), for the type of Work, and the Specification requirements for each specific product involved. If not specified, Developer shall first recommend a product of a manufacturer or appropriate trade association for approval by the District.
- 2.1.2. Materials to be cut and patched include those damaged by the performance of the Work.

3. EXECUTION

3.1. INSPECTION

- 3.1.1. Developer shall inspect existing conditions of the Site and the Work, including elements subject to movement or damage during cutting and patching, excavating and backfilling. After uncovering Work, Developer shall inspect conditions affecting installation of new products.

- 3.1.2. Developer shall report unsatisfactory or questionable conditions in writing to District as indicated in the General Construction Provisions (Exhibit "D" to the Facilities Lease) and shall proceed with Work as indicated in the General Construction Provisions (Exhibit "D" to the Facilities Lease) by District.

3.2. PREPARATION

- 3.2.1. Developer shall provide shoring, bracing and supports as required to maintain structural integrity for all portions of the Project, including all requirements of the Project.
- 3.2.2. Developer shall provide devices and methods to protect other portions of Project from damage.
- 3.2.3. Developer shall, provide all necessary protection from weather and extremes of temperature and humidity for the Project, including without limitation, any work that may be exposed by cutting and patching Work. Developer shall keep excavations free from water.

3.3. ERECTION, INSTALLATION AND APPLICATION

- 3.3.1. With respect to performance, Developer shall:
 - 3.3.1.1. Execute fitting and adjustment of products to provide finished installation to comply with and match specified tolerances and finishes.
 - 3.3.1.2. Execute cutting and demolition by methods that will prevent damage to other Work, and provide proper surfaces to receive installation of repairs and new Work.
 - 3.3.1.3. Execute cutting, demolition excavating, and backfilling by methods that will prevent damage to other Work and damage from settlement.
 - 3.3.1.4. Developer shall employ original installer or fabricator to perform cutting and patching for:
 - 3.3.1.5. Weather-exposed surfaces and moisture-resistant elements such as roofing, sheet metal, sealants, waterproofing, and other trades.
 - 3.3.1.6. Sight-exposed finished surfaces.
- 3.3.2. Developer shall execute fitting and adjustment of products to provide a finished installation to comply with specified products, functions, tolerances, and finishes as shown or specified in the Contract Documents including, without limitation, the Drawings and Specifications.
- 3.3.3. Developer shall fit Work airtight to pipes, sleeves, ducts, conduit, and other penetrations through surfaces. Developer shall conform to all Code requirements for penetrations or the Drawings and Specifications, whichever calls for a higher quality or more thorough requirement. Developer shall maintain integrity of both rated and non-rated fire walls, ceilings, floors, etc.
- 3.3.4. Developer shall restore Work which has been cut or removed. Developer shall install new products to provide completed Work in accordance with requirements of the Contract Documents and as required to match surrounding areas and surfaces.
- 3.3.5. Developer shall refinish all continuous surfaces to nearest intersection as necessary to match the existing finish to any new finish.

END OF DOCUMENT

DEMOLITION WASTE MANAGEMENT**1. GENERAL****1.1. DEFINITIONS**

- 1.1.1. **Construction and Demolition Waste:** Building and site improvement materials and waste materials resulting from construction and demolition or selective demolition operations.
- 1.1.2. **Disposal:** Removal off-site of demolition and construction waste and subsequent sale, recycling, reuse, or deposit in landfill or incinerator acceptable to authorities having jurisdiction.
- 1.1.3. **Recycle:** Recovery of demolition or construction waste for subsequent processing in preparation for reuse.
- 1.1.4. **Salvage:** Recovery of demolition or construction waste and subsequent sale or reuse in another facility.
- 1.1.5. **Salvage and Reuse:** Recovery of demolition or construction waste and subsequent incorporation into the Work.
- 1.1.6. **Waste Management Coordinator:** Developer's designated representative responsible for preparation and execution of demolition waste management plan.

1.2. PERFORMANCE GOALS

- 1.2.1. **General:** Develop waste management plan that results in end-of-Project rates for salvage/recycling of seventy-five percent (75%) by weight of total waste generated by the Work.
- 1.2.2. **Salvage/Recycle Goals:** Salvage and recycle as much nonhazardous construction and demolition waste as possible. District has established a minimum goal of seventy-five percent (75%) by weight of total waste generated by the Work for the following materials:
- Demolition Soils Waste:
 - Green Materials: Trees, stumps, trimmings, and land clearing debris.
 - Asphaltic concrete paving.
 - Concrete.
 - Decorative masonry and rocks.
 - Concrete reinforcing steel.
 - Brick.
 - Concrete masonry units.
 - Wood studs, joists, and sheathing.
 - Plywood and oriented strand board.
 - Wood paneling and wood trim.
 - Interior casework.
 - Structural and miscellaneous steel.
 - Rough hardware.
 - Roofing.
 - Insulation.
 - Windows, doors, and frames.
 - Door hardware.
 - Windows.
 - Glazing.
 - Metal: Ferrous and non-ferrous.
 - Gypsum board.
 - Acoustical tile and panels.
 - Carpet.
 - Carpet pad.
 - Demountable partitions.
 - Equipment:
 - Cabinets.

- Plumbing fixtures and piping.
- Supports and hangers.
- Valves.
- Fire sprinklers.
- Mechanical equipment.
- Refrigerants.
- Electrical conduit.
- Copper wiring.
- Lighting fixtures, lamps and ballasts.
- Electrical devices.
- Switchgear and panel boards.
- Historical items for Archive Project.

1.3. SUBMITTALS

- 1.3.1. **Waste Management Plan:** Submit five (5) copies of plan concurrent with the Schedule of Submittals as indicated in the General Construction Provisions (Exhibit "D" to the Facilities Lease).
- 1.3.2. **Waste Reduction Progress Reports:** Concurrent with each Application for Payment, submit five (5) copies of reports. Include separate reports for demolition and construction waste. Include the following information:
- 1.3.2.1. Material category;
 - 1.3.2.2. Generation point of waste;
 - 1.3.2.3. Total quantity of waste in tons;
 - 1.3.2.4. Quantity of waste salvaged, both estimated and actual in tons;
 - 1.3.2.5. Quantity of waste recycled, both estimated and actual in tons;
 - 1.3.2.6. Total quantity of waste recovered (salvaged plus recycled) in tons; and
 - 1.3.2.7. Total quantity of waste recovered (salvaged plus recycled) as a percentage of total waste.
- 1.3.3. **Forms:** Prepare waste reduction progress reports.
- 1.3.4. **Waste Reduction Calculations:** Before Completion, submit five (5) copies of calculated end-of-Project rates for salvage, recycling, and disposal as a percentage of total waste generated by the Work. Developer may request information from District to assist in preparing these calculations.
- 1.3.5. **Records of Donations:** Indicate receipt and acceptance of salvageable waste donated to individuals and organizations. Indicate whether organization is tax exempt.
- 1.3.6. **Records of Sales:** Indicate receipt and acceptance of salvageable waste sold to individuals and organizations. Indicate whether organization is tax exempt.
- 1.3.7. **Recycling and Processing Facility Records:** Indicate receipt and acceptance of recyclable waste by recycling and processing facilities licensed to accept them. Include manifests, weight tickets, receipts, and invoices.
- 1.3.8. **Landfill and Incinerator Disposal Records:** Indicate receipt and acceptance of waste by landfills and incinerator facilities licensed to accept them. Include manifests, weight tickets, receipts, and invoices.
- 1.3.9. **Qualification Data:** For Developer's Waste Management Coordinator.
- 1.3.10. **Statement of Refrigerant Recovery:** Signed by refrigerant recovery technician responsible for recovering refrigerant, stating that all refrigerant that was present was recovered and that recovery was performed according to EPA regulations. Include name and address of technician and date refrigerant was recovered.
- 1.3.11. **Hazardous Materials Abatement:** Coordinate with other applicable Specifications for the removal of hazardous components of materials to be recycled.

1.4. QUALITY ASSURANCE

- 1.4.1. **Waste Management Coordinator:** Submit qualifications for District's approval.
- 1.4.2. **Regulatory Requirements:** Comply with hauling and disposal regulations of authorities having jurisdiction.

- 1.4.3. **Waste Management Conference:** Conduct conference at Project site to comply with requirements in the Contract Documents. Review methods and procedures related to waste management including, but not limited to, the following:
- 1.4.3.1. Review and discuss waste management plan including responsibilities of Waste Management Coordinator;
 - 1.4.3.2. Review requirements for documenting quantities of each type of waste and its disposition;
 - 1.4.3.3. Review and finalize procedures for materials separation and verify availability of containers and bins needed to avoid delays;
 - 1.4.3.4. Review procedures for periodic waste collection and transportation to recycling and disposal facilities; and
 - 1.4.3.5. Review waste management requirements for each trade.
- 1.4.4. **Quality of Recycled Material for Re-Use On Site:** Coordinate with testing requirements under the appropriate sections.

1.5. WASTE MANAGEMENT PLAN

- 1.5.1. **General:** Develop plan consisting of waste identification, waste reduction work plan, and cost/revenue analysis. Include separate sections in plan for different types of demolition waste. Indicate quantities by weight or volume, but use same units of measure throughout waste management plan.
- 1.5.2. **Waste Identification:** Indicate anticipated types and quantities of demolition and site-clearing waste generated by the Work in accordance with the District as defined below. Include estimated quantities and assumptions for estimates.
- 1.5.2.1. Fully contained, segregated hazardous materials disposal.
 - 1.5.2.1.1. Class I Hazardous Materials Landfill
 - 1.5.2.2. Reuse of building materials or salvageable items.
 - 1.5.2.2.1. Wood trim, interior casework, historical items (Archive Project).
 - 1.5.2.2.2. Windows, doors, hardware.
 - 1.5.2.2.3. Equipment.
 - 1.5.2.3. Source separation of recyclable materials.
 - 1.5.2.3.1. Asphalt.
 - 1.5.2.3.2. Concrete, concrete block, decorative masonry, and rocks.
 - 1.5.2.3.3. Green Materials: Trees, stumps, trimmings, and land-clearing debris.
 - 1.5.2.3.4. Metal: Ferrous and non-ferrous.
 - 1.5.2.3.5. Brick.
 - 1.5.2.3.6. Soil.
 - 1.5.2.3.7. Wood: Flooring, sheathing, structural lumber, finish lumber.
 - 1.5.2.3.8. Gypsum board.
 - 1.5.2.4. On-site crushing of asphalt and concrete for use on or off-site.
 - 1.5.2.5. Mixed debris recycling facilities.
 - 1.5.2.5.1. For materials which cannot be feasibly separated.
 - 1.5.2.5.2. Ship to mixed materials recycling facility.
 - 1.5.2.6. Waste disposal to landfill.
 - 1.5.2.6.1. For all remaining materials which cannot be recycled, reused, separated, or mixed.
 - 1.5.2.6.1.1. Ceiling tiles.
 - 1.5.2.6.1.2. Carpet.
 - 1.5.2.6.1.3. Plaster, stucco.
 - 1.5.2.6.1.4. Mixed demolition debris.
- 1.5.3. **Waste Reduction Work Plan:** List each type of waste and whether it will be salvaged, recycled, or disposed of in landfill or incinerator. Include points of waste generation, total quantity of each type of waste, quantity for each means of recovery, and handling and transportation procedures.

- 1.5.3.1. Salvaged Materials for Reuse: For materials that will be salvaged and reused in this Project, describe methods for preparing salvaged materials before incorporation into the Work.
- 1.5.3.2. Salvaged Materials for Sale: For materials that will be sold to individuals and organizations, include list of their names, addresses, and telephone numbers.
- 1.5.3.3. Salvaged Materials for Donation: For materials that will be donated to individuals and organizations, include list of their names, addresses, and telephone numbers.
- 1.5.3.4. Recycled Materials: Include list of local receivers and processors and type of recycled materials each will accept. Include names, addresses, and telephone numbers.
- 1.5.3.5. Disposed Materials: Indicate how and where materials will be disposed of. Include name, address, and telephone number of each landfill and incinerator facility.
- 1.5.3.6. Handling and Transportation Procedures: Include method that will be used for separating recyclable waste including sizes of containers, container labeling, and designated location on Project site where materials separation will be located.
- 1.5.4. **Cost/Revenue Analysis:** Indicate total cost of waste disposal as if there was no waste management plan and net additional cost or net savings resulting from implementing waste management plan. Include the following:
 - 1.5.4.1. Total quantity of waste.
 - 1.5.4.2. Estimated cost of disposal (cost per unit). Include hauling and tipping fees and cost of collection containers for each type of waste.
 - 1.5.4.3. Total cost of disposal (with no waste management).
 - 1.5.4.4. Revenue from salvaged materials.
 - 1.5.4.5. Revenue from recycled materials.
 - 1.5.4.6. Savings in hauling and tipping fees by donating materials.
 - 1.5.4.7. Savings in hauling and tipping fees that are avoided.
 - 1.5.4.8. Handling and transportation costs. Include cost of collection containers for each type of waste.
 - 1.5.4.9. Net additional cost or net savings from waste management plan.
- 1.5.5. **Forms:** Prepare waste management plan.

2. PRODUCTS

Not Used

3. EXECUTION

3.1. PLAN IMPLEMENTATION

- 3.1.1. **General:** Provide handling, containers, storage, signage, transportation, and other items as required to implement waste management plan during the entire duration of the Contract.
- 3.1.2. **Waste Management Coordinator:** Waste management coordinator shall work with representative of the District for implementing, monitoring, and reporting status of waste management work plan. Coordinator shall be present at Project site for duration of project.
- 3.1.3. **Training:** Train workers, subcontractors, and suppliers on proper waste management procedures, as appropriate for the Work occurring at Project site.
 - 3.1.3.1. Distribute waste management plan to everyone concerned within 3 days of submittal return.
 - 3.1.3.2. Distribute waste management plan to entities when they first begin work on-site. Review plan procedures and locations established for salvage, recycling, and disposal.
- 3.1.4. **Site Access and Temporary Controls:** Conduct waste management operations to ensure minimum interference with roads, streets, walks, walkways, and other adjacent occupied and used facilities.

- 3.1.4.1. Designate and label specific areas on Project site necessary for separating materials that are to be salvaged, recycled, reused, donated, and sold.
- 3.1.4.2. Comply with Temporary Facilities and Controls, for controlling dust and dirt, environmental protection, and noise control.
- 3.1.5. **Weighing and Documentation:** Separate and weigh all items to be recycled or salvaged.
 - 3.1.5.1. Weight shall be measured by the ton or fraction thereof.
 - 3.1.5.2. Measurement of weight shall be by a properly calibrated scale bearing a current seal of the appropriate weights and measures representation.
 - 3.1.5.3. Measured weights shall be recorded along with all other required documentation.
- 3.2. DISPOSITION OF SALVAGED MATERIALS AND ITEMS**
 - 3.2.1. Salvaged Materials for Reuse in the Work:
 - 3.2.1.1. Clean or wash salvaged items.
 - 3.2.1.2. Crush and stock pile material for re-use on-site or transport off site.
 - 3.2.1.3. Stockpile materials in an area which is safe from standing water or erosion.
 - 3.2.1.4. Protect stockpiles until ready for re-use.
 - 3.2.1.5. Re-install salvaged materials to comply with installation requirements for new materials.
 - 3.2.2. Salvaged Items are not permitted to be sold on Project site.
 - 3.2.3. Salvaged Items shall be removed from project site for disposition at an appropriate salvage supply yard.
 - 3.2.4. Salvaged Items for District's Use: None.
- 3.3. RECYCLING DEMOLITION WASTE, GENERAL**
 - 3.3.1. **General:** Recycle paper and beverage containers used by on-site workers.
 - 3.3.2. **Waste Recycling Receivers and Processors:** Licensed entity normally engaged in the business of receiving, recycling, and processing waste materials with a minimum of 5 years of documented experience with the types of waste products to be processed under the provisions of this section.
 - 3.3.3. **Recycling Incentives:** Revenues, savings, rebates, tax credits, and other incentives received for recycling waste materials shall be shared equally by District and Developer
 - 3.3.4. **Procedures:** Separate recyclable waste from other waste materials, trash, and debris. Separate recyclable waste by type at Project site to the maximum extent practical.
 - 3.3.4.1. Provide appropriately marked containers or bins for controlling recyclable waste until they are removed from Project site. Include list of acceptable and unacceptable materials at each container and bin.
 - 3.3.4.2. Inspect containers and bins for contamination and remove contaminated materials if found.
 - 3.3.4.3. Stockpile processed materials on-site without intermixing with other materials. Place, grade, and shape stockpiles to drain surface water. Cover to prevent windblown dust.
 - 3.3.4.4. Stockpile materials away from construction area. Do not store within drip line of remaining trees.
 - 3.3.4.5. Store components off the ground and protect from the weather.
 - 3.3.4.6. Remove recyclable waste off District's property and transport to recycling receiver or processor.
- 3.4. RECYCLING DEMOLITION WASTE**
 - 3.4.1. **Bituminous Concrete Paving:** Break up and transport paving to asphalt-recycling facility, or process on-site.
 - 3.4.2. **Concrete Reinforcement:** Remove reinforcement and other metals from concrete and sort with other metals.
 - 3.4.3. **Concrete:** Break up and transport to concrete-recycling facility or process on site.
 - 3.4.4. **Concrete:** Crush concrete and screen to comply with requirements in Specifications regarding Earthwork: Re-use as fill at contractor's option.
 - 3.4.5. **Masonry Reinforcement:** Remove metal reinforcement, anchors, and ties from masonry and sort with other metals.

- 3.4.6. **Masonry:** Crush masonry and screen to comply with requirements in Specifications regarding Earthwork for use as satisfactory soil for fill.
 - 3.4.7. **Wood Materials:** Separate lumber, engineered wood products, panel products, and treated wood materials. Dispose of as salvage or recycle for filler or mulch at an appropriate facility.
 - 3.4.8. **Metals:** Separate metals by type.
 - 3.4.8.1. Structural Steel and Other Metals: Separate members according to size, type of member, and length.
 - 3.4.8.2. Recycle bolts, nuts, washers, and other rough hardware.
 - 3.4.8.3. Non-Ferrous Metals: Separate by type.
 - 3.4.9. **Asphalt Shingle Roofing:** Separate organic and glass-fiber asphalt shingles and felts. Remove and dispose of nails, staples, and accessories.
 - 3.4.10. **Gypsum Board:** Stack large clean pieces on wood pallets and store in a dry location. Remove edge trim and sort with other metals. Remove and dispose of fasteners.
 - 3.4.11. **Acoustical Ceiling Panels and Tile:** Stack large clean pieces on wood pallets and store in a dry location.
 - 3.4.12. **Acoustical Ceiling Suspension Systems:** Separate suspension system, trim, and other metals from panels and tile and sort with other metals.
 - 3.4.13. **Carpet and Pad:** Roll large pieces tightly after removing debris, trash, adhesive, and tack strips.
 - 3.4.14. **Equipment: Drain tanks, piping, and fixtures:** Seal openings with caps or plugs. Protect equipment from exposure to weather. Sort and recycle by types of metal.
 - 3.4.15. **Plumbing Fixtures:** Separate and recycle.
 - 3.4.16. **Piping:** Reduce piping to straight lengths and arrange by type and size. Separate supports, hangers, valves, sprinklers, and other components by type and size.
Lighting Fixtures: Remove lamps and separate fixtures by type and protect from breakage and weather.
 - 3.4.17. **Electrical Devices:** Separate switches, receptacles, switchgear, transformers, meters, panelboards, circuit breakers, and other devices by type.
 - 3.4.18. **Conduit:** Reduce conduit to straight lengths and store by type and size.
 - 3.4.19. **Green Materials:** Separate out roots, stumps, trunks, shrubs, mulch, and other green matter and transport off-site for appropriate processing.
- 3.5. DISPOSAL OF WASTE**
- 3.5.1. **General:** Except for items or materials to be salvaged, recycled, or otherwise reused, remove waste materials from Project site and legally dispose of them in a landfill or incinerator acceptable to authorities having jurisdiction.
 - 3.5.2. Do not allow waste materials that are to be disposed of accumulate on-site. Remove and transport debris in a manner that will prevent spillage on or off site.
 - 3.5.3. **Burning:** Do not burn and waste materials on-site.
 - 3.5.4. **Disposal:** Transport waste materials off site and legally dispose of them.

END OF DOCUMENT

OPERATION AND MAINTENANCE DATA**1. GENERAL****1.1. QUALITY ASSURANCE**

Developer shall prepare instructions and data by personnel experienced in maintenance and operation of described products.

1.2. FORMAT

- 1.2.1. Developer shall prepare data in the form of an instructional manual entitled "OPERATIONS AND MAINTENANCE MANUAL & INSTRUCTIONS" ("Manual").
- 1.2.2. Binders: Developer shall use commercial quality, 8-1/2 by 11 inch, three-side rings, with durable plastic covers; two inch maximum ring size. When multiple binders are used, Developer shall correlate data into related consistent groupings.
- 1.2.3. Cover: Developer shall identify each binder with typed or printed title "OPERATION AND MAINTENANCE MANUAL & INSTRUCTIONS"; and shall list title of Project and identify subject matter of contents.
- 1.2.4. Developer shall arrange content by systems process flow under section numbers and sequence of Table of Contents of the Contract Documents.
- 1.2.5. Developer shall provide tabbed fly leaf for each separate Product and system, with typed description of Product and major component parts of equipment.
- 1.2.6. Text: The content shall include Manufacturer's printed data, or typewritten data on 24 pound paper.
- 1.2.7. Drawings: Developer shall provide with reinforced punched binder tab and shall bind in with text; folding larger drawings to size of text pages.

1.3. CONTENTS, EACH VOLUME

- 1.3.1. Table of Contents: Developer shall provide title of Project; names, addresses, and telephone numbers of the Architect, any engineers, subconsultants, Subcontractor(s), and Developer with name of responsible parties; and schedule of Products and systems, indexed to content of the volume.
- 1.3.2. For Each Product or System: Developer shall list names, addresses, and telephone numbers of Subcontractor(s) and suppliers, including local source of supplies and replacement parts.
- 1.3.3. Product Data: Developer shall mark each sheet to clearly identify specific Products and component parts, and data applicable to installation. Delete inapplicable information.
- 1.3.4. Drawings: Developer shall supplement Product data to illustrate relations of component parts of equipment and systems, to show control and flow diagrams. Developer shall not use Project Record Documents as maintenance drawings.
- 1.3.5. Text: The Developer shall include any and all information as required to supplement Product data. Developer shall provide logical sequence of instructions for each procedure, incorporating manufacturer's instructions.

1.4. MANUAL FOR MATERIALS AND FINISHES

- 1.4.1. Building Products, Applied Materials, and Finishes: Developer shall include Product data, with catalog number, size, composition, and color and texture designations. Developer shall provide information for re-ordering custom manufactured Products.
- 1.4.2. Instructions for Care and Maintenance: Developer shall include Manufacturer's recommendations for cleaning agents and methods, precautions against detrimental agents and methods, and recommended schedule for cleaning and maintenance.
- 1.4.3. Moisture Protection and Weather Exposed Products: Developer shall include Product data listing applicable reference standards, chemical composition, and details of installation. Developer shall provide recommendations for inspections, maintenance, and repair.
- 1.4.4. Additional Requirements: Developer shall include all additional requirements as specified in the Specifications.
- 1.4.5. Developer shall provide a listing in Table of Contents for design data, with tabbed fly sheet and space for insertion of data.

1.5. MANUAL FOR EQUIPMENT AND SYSTEMS

- 1.5.1. Each Item of Equipment and Each System: Developer shall include description of unit or system, and component parts and identify function, normal operating characteristics, and limiting conditions. Developer shall include performance curves, with engineering data and tests, and complete nomenclature, and commercial number of replaceable parts.
 - 1.5.2. Panelboard Circuit Directories: Developer shall provide electrical service characteristics, controls, and communications.
 - 1.5.3. Developer shall include color coded wiring diagrams as installed.
 - 1.5.4. Operating Procedures: Developer shall include start-up, break-in, and routine normal operating instructions and sequences. Developer shall include regulation, control, stopping, shut-down, and emergency instructions. Developer shall include summer, winter, and any special operating instructions.
 - 1.5.5. Maintenance Requirements: Developer shall include routine procedures and guide for trouble-shooting; disassembly, repair, and reassembly instructions; and alignment, adjusting, balancing, and checking instructions.
 - 1.5.6. Developer shall provide servicing and lubrication schedule, and list of lubricants required.
 - 1.5.7. Developer shall include manufacturer's printed operation and maintenance instructions.
 - 1.5.8. Developer shall include sequence of operation by controls manufacturer.
 - 1.5.9. Developer shall provide original manufacturer's parts list, illustrations, assembly drawings, and diagrams required for maintenance.
 - 1.5.10. Developer shall provide control diagrams by controls manufacturer as installed.
 - 1.5.11. Developer shall provide Developer's coordination drawings, with color coded piping diagrams as installed.
 - 1.5.12. Developer shall provide charts of valve tag numbers, with location and function of each valve, keyed to flow and control diagrams.
 - 1.5.13. Developer shall provide list of original manufacturer's spare parts, current prices, and recommended quantities to be maintained in storage.
 - 1.5.14. Additional Requirements: Developer shall include all additional requirements as specified in Specification(s).
 - 1.5.15. Developer shall provide a listing in Table of Contents for design data, with tabbed fly sheet and space for insertion of data.
- 1.6. SUBMITTAL**
- 1.6.1. Concurrent with the Schedule of Submittals as indicated in the General Construction Provisions (Exhibit "D" to the Facilities Lease), Developer shall submit to the District for review two (2) copies of a preliminary draft of proposed formats and outlines of the contents of the Manual.
 - 1.6.2. For equipment, or component parts of equipment put into service during construction and to be operated by District, Developer shall submit draft content for that portion of the Manual within ten (10) days after acceptance of that equipment or component.
 - 1.6.3. On or before the Developer submits its final application for payment, Developer shall submit two (2) copies of a complete Manual in final form. The District will provide comments to Developer and Developer must revise the content of the Manual as required by District prior to District's approval of Developer's final Application for Payment.
 - 1.6.4. Developer must submit two (2) copies of revised Manual in final form within ten (10) days after receiving District's comments. Failure to do so will be a basis for the District withholding funds sufficient to protect itself for Developer's failure to provide a final Manual to the District. All final documents to be concurrently provided to the District in an electronic format.

END OF DOCUMENT

WARRANTIES**1. GENERAL****1.1. FORMAT**

- 1.1.1. Binders: Developer shall use commercial quality, 8-1/2 by 11 inch, three-side rings, with durable plastic covers; two inch maximum ring size.
- 1.1.2. Cover: Developer shall identify each binder with typed or printed title "WARRANTIES" and shall list title of Project.
- 1.1.3. Table of Contents: Developer shall provide title of Project; name, address, and telephone number of Developer and equipment supplier, and name of responsible principal. Developer shall identify each item with the number and title of the specific Specification, document, provision, or section in which the name of the Product or work item is specified.
- 1.1.4. Developer shall separate each warranty with index tab sheets keyed to the Table of Contents listing, providing full information and using separate typed sheets as necessary. Developer shall list each applicable and/or responsible Subcontractor(s), supplier(s), and/or manufacturer(s), with name, address, and telephone number of each responsible principal(s).

1.2. PREPARATION

- 1.2.1. Developer shall obtain warranties, executed in duplicate by each applicable and/or responsible subcontractor(s), supplier(s), and manufacturer(s), within ten (10) days after completion of the applicable item or work. Except for items put into use with District's permission, Developer shall leave date of beginning of time of warranty until the date of completion is determined.
- 1.2.2. Developer shall verify that warranties are in proper form, contain full information, and are notarized, when required.
- 1.2.3. Developer shall co-execute submittals when required.
- 1.2.4. Developer shall retain warranties until time specified for submittal.

1.3. TIME OF SUBMITTALS

- 1.3.1. For equipment or component parts of equipment put into service during construction with District's permission, Developer shall submit a draft warranty for that equipment or component within ten (10) days after acceptance of that equipment or component.
- 1.3.2. On or before the Developer submits its final application for payment, Developer shall submit all warranties and related documents in final form. The District will provide comments to Developer and Developer must revise the content of the warranties as required by District prior to District's approval of Developer's final Application for Payment.
- 1.3.3. For items of Work that are not completed until after the date of Completion, Developer shall provide an updated warranty for those item(s) of Work within ten (10) days after acceptance, listing the date of acceptance as start of warranty period.

END OF DOCUMENT

RECORD DOCUMENTS**1. RECORD DRAWINGS****1.1. GENERAL**

- 1.1.1. "Record Drawings" may also be referred to in the Contract as "As-Built Drawings."
- 1.1.2. As indicated in the Contract Documents, District will provide Developer with one set of reproducible plans of the original Contract Drawings.
- 1.1.3. Developer shall maintain at each Project Site one (1) set of marked-up plans and shall transfer all changes and information to those marked-up plans, as often as required in the Contract Documents, but in no case less than once each month. Developer shall submit to the Project Inspector one set of reproducible vellums of the Project Record Drawings ("As-Builts") showing all changes incorporated into the Work since the preceding monthly submittal. The As-Builts shall be available at the Project Site. The Developer shall submit reproducible vellums at the conclusion of the Project following review of the blueline prints.
- 1.1.4. Label and date each Record Drawing "RECORD DOCUMENT" in legibly printed letters.
- 1.1.5. All deviations in construction, including but not limited to pipe and conduit locations and deviations caused by without limitation Change Orders, Construction Directives, RFI's, and Addenda, shall be accurately and legibly recorded by Developer
- 1.1.6. Locations and changes shall be done by Developer in a neat and legible manner and, where applicable, indicated by drawing a "cloud" around the changed or additional information.

1.2. RECORD DRAWING INFORMATION

- 1.2.1. Developer shall record the following information:
 - 1.2.1.1. Locations of Work buried under or outside each building, including, without limitation, all utilities, plumbing and electrical lines, and conduits.
 - 1.2.1.2. Actual numbering of each electrical circuit.
 - 1.2.1.3. Locations of significant Work concealed inside each building whose general locations are changed from those shown on the Contract Drawings.
 - 1.2.1.4. Locations of all items, not necessarily concealed, which vary from the Contract Documents.
 - 1.2.1.5. Installed location of all cathodic protection anodes.
 - 1.2.1.6. Deviations from the sizes, locations, and other features of installations shown in the Contract Documents.
 - 1.2.1.7. Locations of underground work, points of connection with existing utilities, changes in direction, valves, manholes, catch basins, capped stubouts, invert elevations, etc.
 - 1.2.1.8. Sufficient information to locate Work concealed in each building with reasonable ease and accuracy.
- 1.2.2. In some instances, this information may be recorded by dimension. In other instances, it may be recorded in relation to the spaces in the building near which it was installed.
- 1.2.3. Developer shall provide additional drawings as necessary for clarification.
- 1.2.4. Developer shall provide reproducible record drawings, made from final Shop Drawings marked "No Exceptions Taken" or "Approved as Noted."

2. RECORD SPECIFICATIONS

Developer shall mark each section legibly to record manufacturer, trade name, catalog number, and supplier of each Product and item of equipment actually installed.

3. MAINTENANCE OF RECORD DOCUMENTS

- 3.1. Developer shall store Record Documents apart from documents used for construction as follows:
 - 3.1.1. Provide files and racks for storage of Record Documents.
 - 3.1.2. Maintain Record Documents in a clean, dry, legible condition and in good order.
- 3.2. Developer shall not use Record Documents for construction purposes.

END OF DOCUMENT

COMMISSIONING**4. GENERAL****4.1. SUMMARY**

- 4.1.1. Commissioning is a process for validating and documenting that the facility and its systems are constructed and perform in conformity with the Contract Documents.
- 4.1.2. The objective of the commissioning process is to verify that the performance of the facility and its systems meet or exceed the design intent.
- 4.1.3. Commissioning includes special facility start-up processes used to bring the facility to a fully operational state, free of deficiencies in an efficient and timely manner.
- 4.1.4. Training on related systems and equipment operation and maintenance shall be scheduled to commence only after start-up is complete and systems are verified to be 100% complete and functional.

4.2. DESCRIPTION

- 4.2.1. **Developer Startup:** Sub-phase of Developer's work ending with Acceptance of Work, during which Developer performs a pre-planned program of activities including starting, testing, inspecting, adjusting balancing, correcting deficiencies and other similar activities.
 - 4.2.1.1. The District, Construction Manager and Architect and the Inspector shall be present to observe, inspect and identify deficiencies in building systems operations.
- 4.2.2. The completion of startup means the entire Construction Project including startup and fine tuning has been performed to the requirements of the Contract Documents and is verified in writing by the District, Construction Manager and Architect.
- 4.2.3. **Fine Tuning:** Fine tuning is the responsibility of Developers after District occupancy and ending one (1) year after District occupancy. During this time the Developer is responsible for optimizing systems and correcting deficiencies arising under normal operating conditions.
 - 4.2.3.1. Includes a period after occupancy where systems are optimized under "live" operating conditions and all construction deficiencies are corrected.
 - 4.2.3.2. Fine Tuning shall extend from date of District occupancy to one year after occupancy.

4.3. DEFINITION OF TERMS

- 4.3.1. **Contractor's Pre-Commissioning Checklists:** Includes installation and start-up items as specified to be completed by the appropriate contractors prior to operational verification through the functional testing process.
- 4.3.2. **Installation Verification Process:** Includes the on-site inspection and review of related system components for conformance to Contract Documents. The Developer shall verify systems readiness for functional testing procedures prior to the start of functional testing. Deficiencies will be documented by the Inspector for future resolution.
- 4.3.3. **Functional Performance Testing Process:** Includes the documented testing of system parameters, under actual or simulated operating conditions. Final performance commissioning of systems will begin only after the appropriate Developer certifies that systems are 100% complete and ready for functional testing. The Developer will be required to schedule, coordinate and perform device tests, calibration and functional performance test procedures.
- 4.3.4. **Deficiencies and Resolutions List:** Includes a list of noted deficiencies discovered as a result of the commissioning process. This list also includes the current disposition of issues, and the date of final resolution as confirmed by the Construction Manager and Inspector. Deficiencies are defined as those issues where products execution or performance does not satisfy the Project Contract Documents and/or the design intent.

4.4. COMMISSIONING SCHEDULE

- 4.4.1. Provide schedules for Developer Start-Up work.
- 4.4.2. Incorporate in overall construction schedule.

- 4.4.3. Contractor's activities, which will be performed as specified under Fine Tuning, shall be completed within one (1) year from date of occupancy by the District.

4.5. SUBMITTALS

- 4.5.1. Submit Draft and Final Developer Start-up Forms as described in this Document. Submit Draft Report for Construction Manager and Architect's review and comment prior to Final Submission. Submit Final Report not later than twenty weeks before scheduled date of Acceptance of Work.
- 4.5.2. Prepare and submit one copy of report form to be used in preparation of reports for:
- 4.5.2.1. Food Service Equipment.
 - 4.5.2.2. Gymnasium Equipment and Scoreboards
 - 4.5.2.3. Laboratory Fume Hoods
 - 4.5.2.4. Elevators
 - 4.5.2.5. Each mechanical system specified in the Specifications.
 - 4.5.2.6. Each Electrical system specified in the Specifications.
- 4.5.3. Each System Report shall be submitted including the following:
- 4.5.3.1. Project Name
 - 4.5.3.2. Name of System
 - 4.5.3.3. Index of report's content
 - 4.5.3.4. Adjacent to list of equipment, columns to indicate status of equipment operation, to date and to sign off equipment start-up.
 - 4.5.3.5. Space to record equipment and operational problems which cannot be corrected with scheduled Developer Start-Up program and which may delay Acceptance of Work.
 - 4.5.3.6. Manufacturer's equipment start-up reports.
 - 4.5.3.7. Systems' testing, balancing, and adjusting reports.
 - 4.5.3.8. Equipment Report Forms shall include the following: Project name, name of equipment, starting and testing procedures to be performed and observations and test results to be recorded.

4.6. COMMISSIONING DUTIES AND RESPONSIBILITIES

- 4.6.1. Developer Duties and Responsibilities:
- 4.6.1.1. Assure the participation and cooperation of Subcontractors and Suppliers under their jurisdictions as required to complete the commissioning process.
 - 4.6.1.2. Complete Commissioning Report Forms. Reports are to be completed in a neat easily readable condition.
 - 4.6.1.3. Complete the respective start-up and check out procedures and insure readiness of equipment and systems prior to the start of the functional performance testing. Written confirmation of system readiness for performance testing is required.
 - 4.6.1.4. Provide qualified representatives for the functional performance commissioning process.
 - 4.6.1.5. Assure that all subcontractors, suppliers, test and balance, controls, etc. include in their respective contracts cost necessary to participate in and complete the commissioning process.
- 4.6.2. **Duties and Responsibilities of Others for Commissioning:** The commissioning process requires the active participation of the Construction Manager, District, Architect and any other related Consultants on the project.

4.7. SYSTEM FAILURES

After a second failure of a system to successfully meet the criteria as set for in the functional performance testing process, the Developer shall reimburse the District for cost associated with any additional retesting required due to uncorrected deficiencies. Costs shall include salary, benefits, overhead, travel costs and per diem lodging costs if applicable.

END OF DOCUMENT

PROJECT MANUAL

for

Building S – Science Lab Modernization

at

Mt. Diablo High School
2450 Grant Street
Concord, California 94520

MT. DIABLO UNIFIED SCHOOL DISTRICT
Concord, California

Prepared by:

Nacht & Lewis Architects
600 Q Street, Suite 100
Sacramento, California 95811

Nacht & Lewis Project No. Y1211.00

February 19, 2013

Project Manual
for

Mt. Diablo Unified School District
Building S Science Lab Modernization at Mt. Diablo High School

NACHT & LEWIS PROJECT NO. Y1211.00

Owner:

Mount Diablo Unified School District

1480 Gasoline Alley
Concord, California 94520
(925) 824-7440

Peder Pedersen – Director of Facilities

DSA Approval _____

DSA Application No. 01-xxxxxx

DSA File No. x-xx

Architect:

Nacht & Lewis Architects

600 Q. Street, Suite 100
Sacramento, California 95811
(916) 329-4000

Brian J. Maytum – AIA, LEED AP

California Registration #C-26867

Structural Engineer:

Barrish Pelham & Partners, Inc.

3001 E. Street
Sacramento, California 95816
(916) 418-9100

Stephen H. Pelham

California Registration #S-2558

Mechanical Engineer/Engineer of Record

Capitol Engineering Consultants

11020 Sun Center Dr., Suite 100
Rancho Cordova, California 95670
(916) 851-3500

Thomas A. Duval

California Registration #M-22836

Electrical Engineer:

Harry Yee & Associates, Inc.

4920 Freeport Blvd., Suite D
Sacramento, California 95822
(916) 454-5319

David Yu

California Registration #E-14987

PROJECT MANUAL AND SPECIFICATIONS
FOR

**Mt. Diablo Unified School District
Building S Science Lab Modernization at Mt. Diablo High School**

TABLE OF CONTENTS

BIDDING REQUIREMENTS

CONTRACT FORMS

GENERAL CONDITIONS

SPECIAL CONDITIONS

<u>DIVISION NO.</u>	<u>SECTION TITLE</u>
<u>DIVISION 0</u>	<u>GENERAL REQUIREMENTS</u>
Section 00 01 01	Title Page
Section 00 01 10	Table of Contents
Section 00 01 15	List of Drawings, Tables and Schedules
Section 00 11 10	Invitation to Bid
Section 00 11 50	Request for Qualifications
Section 00 21 10	Instructions to Bidders
Section 00 31 19	Existing Conditions
Section 00 31 32	Geotechnical Data
Section 00 41 13	Bid Form
Section 00 43 13	Bid Bond (Security) Form
Section 00 43 36	Designated Subcontractors List
Section 00 45 01	Site-Visit Certification
Section 00 45 19	Noncollusion Affidavit
Section 00 45 26	Worker's Compensation Certification
Section 00 45 50	Prevailing Wage Certification
Section 00 45 55	DVBE Participation Certification
Section 00 45 60	Drug-Free Workplace Certification
Section 00 45 65	Tobacco-Free Environment Certification
Section 00 45 70	Hazardous Materials Certification
Section 00 45 75	Lead-Based Materials Certification
Section 00 45 80	Imported Materials Certification
Section 00 45 85	Criminal Background Investigation/Fingerprinting Certification
Section 00 45 90	Roofing – PCC 3006 Certification
Section 00 51 00	Notice of Award
Section 00 52 13	Agreement
Section 00 54 50	Escrow of Bid Documentation
Section 00 54 55	Escrow Agreement in Lieu of Retention
Section 00 54 60	Hazardous Materials Proc and Req
Section 00 54 65	LCP Information and Forms – Jan 31 2012
Section 00 55 00	Notice to Proceed
Section 00 61 14	Performance Bond
Section 00 61 15	Payment Bond
Section 00 63 00	District Contract Forms
Section 00 65 00	District Closeout Forms
Section 00 65 25	Agreement and Release
Section 00 65 36	Warranty – Guarantee Form
Section 00 70 00	General Conditions

Section 00 71 00	Special Conditions
Section 00 73 16	Bidder's Statement Insurance
Section 00 73 36	EEOC Certificate

Exhibit A	School Year Calendar
Exhibit B	Preliminary Construction Schedule
Exhibit C	Asbestos Abatement Specifications/Procedures
Exhibit D	Lead-Based Paint Surface Preparation Specifications
Exhibit E	PCB Ballast/Fluorescent Tube Handling Procedures
Exhibit F	DSA Structural Test and Inspection Requirements (DSA-103)
Exhibit G	Drawing Index

<u>DIVISION 1</u>	<u>GENERAL REQUIREMENTS</u>
Section 01 11 00	Summary of Work
Section 01 12 10	Contract Forms and Submittals
Section 01 20 00	Price and Payment Procedures
Section 01 21 00	Allowances
Section 01 23 00	Alternates and Unit Pricing
Section 01 25 10	Product Options and Substitutions
Section 01 26 00	Contract Modification Procedures
Section 01 26 10	Requests for Information - Procedures
Section 01 31 00	Coordination and Meetings
Section 01 32 16	Construction Schedule
Section 01 33 00	Submittals
Section 01 35 13	Special Project Procedures
Section 01 35 45	CHPS
Section 01 41 00	Regulatory Requirements
Section 01 42 13	Abbreviations and Acronyms
Section 01 42 16	General Definitions
Section 01 45 29	Testing Laboratory Services
Section 01 50 00	Temporary Facilities and Controls
Section 01 52 10	Site Standards
Section 01 56 39	Temporary Tree and Plant Protection
Section 01 57 10	SWPPP
Section 01 60 00	Materials and Equipment
Section 01 66 10	Delivery, Storage and Handling
Section 01 70 10	Contract Closeout and Final Cleaning
Section 01 71 10	Field Engineering
Section 01 73 10	Cutting and Patching
Section 01 74 10	Demolition Waste Management
Section 01 78 23	Operation and Maintenance Data
Section 01 78 36	Warranties
Section 01 78 39	Record Documents
Section 01 91 00	Commissioning

<u>DIVISION 2</u>	<u>SITWORK</u>
Section 02 41 00	Demolition

<u>DIVISION 3</u>	<u>Concrete</u>
Section 03 30 00	Cast-in-Place Concrete

<u>DIVISION 5</u>	<u>Metals</u>
Section 05 40 00	Cold Formed Metal Framing
Section 05 50 00	Metal Fabrications

DIVISION 6

Section 06 10 00
 Section 06 20 00
 Section 06 41 16
 Section 06 83 16

WOOD AND PLASTIC

Rough Carpentry
 Finish Carpentry
 Plastic Laminate Clad Architectural Cabinets
 Fiberglass Reinforced Paneling

DIVISION 7

Section 07 21 00
 Section 07 26 00
 Section 07 51 13
 Section 07 60 00
 Section 07 84 00
 Section 07 92 00

THERMAL AND MOISTURE CONTROL

Thermal Insulation
 Vapor Retarders
 Built Up Bituminous Roofing Repair
 Flashing and Sheet Metal
 Firestopping
 Joint Sealants

DIVISION 8

Section 08 11 00
 Section 08 14 16
 Section 08 31 13
 Section 08 33 26
 Section 08 51 13
 Section 08 71 00

DOORS AND WINDOWS

Metal Doors and Frames
 Flush Wood Doors
 Access Doors and Frames
 Overhead Coiling Doors
 Aluminum Windows
 Door Hardware

DIVISION 9

Section 09 21 16
 Section 09 22 36
 Section 09 24 00
 Section 09 30 13
 Section 09 51 00
 Section 09 65 00
 Section 09 91 00
 Section 09 92 16

FINISHES

Gypsum Board Assemblies
 Lath
 Cement Plastering
 Ceramic Tile
 Acoustical Ceilings
 Resilient Flooring
 Painting
 Vinyl Coated Fabric Wall Coverings

DIVISION 10

Section 10 00 00
 Section 10 11 00
 Section 10 14 00
 Section 10 28 00

SPECIALTIES

Specialties
 Visual Display Units
 Signage
 Toilet and Bath Accessories

DIVISION 22

Section 22 00 50
 Section 22 10 00
 Section 22 40 00
 Section 22 50 00

PLUMBING

Basic Plumbing Materials & Methods
 Plumbing Piping Systems
 Plumbing Fixtures
 Plumbing Equipment

DIVISION 23

Section 23 00 50
 Section 23 80 00

HEATING VENTING AIR CONDITIONING

Basic HVAC Materials & Methods
 Heating Venting & Air Conditioning

DIVISION 26

Section 26 00 00
 Section 26 05 00
 Section 26 50 00

ELECTRICAL

Electrical General Requirements
 Basic Materials & Methods
 Lighting

DIVISION 27

Section 27 05 00
 Section 27 05 26

COMMUNICATIONS

Common Work Results for Communication
 Grounding Bonding for Communications Systems

Section 27 05 29	Hangers and Supports for Communication Systems
Section 27 05 33	Conduits & Backboxes for Communication Systems
Section 27 05 39	Surface Raceways for Communications Systems
Section 27 05 53	Identification for Communication Systems
Section 27 10 00	Structured Cabling, Basic Materials & Methods
Section 27 11 16	Communications Cabinets, Rack Frame
Section 27 11 19	Communication Termination Blocks & Patch Panels
Section 27 11 23	Communications Cable Management
Section 27 11 26	Communications Rack Mounted Power Protection and Power Strips
Section 27 13 00	Communications Indoor Backbone Cabling
Section 27 15 00	Communications Horizontal Cabling

DIVISION 28

Section 28 31 00

ELECTRONIC SAFETY & SECURITY

Fire Alarm System

DIVISION 31

Section 31 00 00

Section 31 23 00

EARTHWORKS

Earthwork

Excavation and Fill

DIVISION 32

Section 32 12 16

Section 32 13 13

Section 32 17 13.19

Section 32 17 26

Section 32 31 13

Section 32 80 01

Section 32 91 20

EXTERIOR IMPROVEMENTS

Asphalt Paving

Concrete Paving

Precast Concrete Parking Bumpers

Tactile Warning Surfaces

Chain Link Fences and Gates

Irrigation System Repair

Landscaping Repair

END OF TABLE OF CONTENTS

Drawing Index
for

**Mt. Diablo Unified School District
Building S Science Lab Modernization at Mt. Diablo High School**

NLA PROJECT NO. Y1211,00

TO	TITLE SHEET
A1.0	OVERALL SITE PLAN
A1.1	ENLARGED SITE PLAN
A1.2	ENLARGED PAVING PLAN
A1.3	SITE DETAILS
A2.0	BUILDING DEMOLITION PLAN
A3.0	PARTIAL FLOOR PLAN - EAST
A3.1	PARTIAL FLOOR PLAN - WEST
A4.0	PARTIAL REFLECTED CEILING PLAN - EAST
A4.1	PARTIAL REFLECTED CEILING PLAN - WEST
A5.0	ROOF PLAN
A6.0	PARTIAL FLOOR FINISH MARKING PLAN - EAST
A6.1	PARTIAL FLOOR FINISH MARKING PLAN - WEST
A6.2	OPENING & FINISH SCHEDULE
A6.3	SIGNAGE DETAILS
A7.0	EXTERIOR ELEVATIONS - DEMOLITION
A7.1	EXTERIOR ELEVATIONS - NEW WORK
A8.0	DETAILS
A8.1	DETAILS
A8.2	REFERENCE PHOTOS
A9.0	INTERIOR ELEVATIONS
A9.1	INTERIOR ELEVATIONS
A9.2	INTERIOR ELEVATIONS
A9.3	INTERIOR ELEVATIONS
A9.4	INTERIOR ELEVATIONS
A9.5	INTERIOR ELEVATIONS

STRUCTURAL:

S0.1	GENERAL NOTES
S0.2	TYPICAL DETAILS
S2.1	FOUNDATION PLAN

MECHANICAL:

M0.1	HVAC LEGEND & NOTES
M0.2	HVAC EQUIPMENT SCHEDULES
M2.0	BUILDING HVAC DEMOLITION PLAN
M2.1	BUILDING HVAC PLAN
M4.0	BUILDING HVAC DEMOLITION ROOF PLAN
M4.1	BUILDING HVAC ROOF PLAN
M5.1	HVAC DETAILS

PLUMBING:

P0.1	PLUMBING LEGEND & NOTES
P0.2	PLUMBING FIXTURE SPECIFICATION
P1.1	PLUMBING SITE PLAN
P2.0	BUILDING PLUMBING DEMOLITION PLAN

P3.0	BUILDING PLUMBING PLAN
P3.1	BUILDING PLUMBING PLAN
P5.1	PLUMBING DETAILS

ELECTRICAL:

E0.1	ELECTRICAL SYMBOLS LIST & ABBREVIATIONS
E0.2	ELECTRICAL TITLE 24
E1.1	LIGHTING AND FIRE ALARM DEMOLITION PLAN
E1.2	POWER AND SIGNAL DEMOLITION PLAN
E2.0	LIGHTING FLOOR PLAN
E3.0	POWER FLOOR PLAN
E4.0	SIGNAL FLOOR PLAN
E4.1	A/V FLOOR PLAN
E5.0	FIRE ALARM FLOOR PLAN
E7.1	ELECTRICAL PANEL SCHEDULES
E7.2	MECHANICAL EQUIPMENT SCHEDULES

Sheets For Reference Only

A1	DOOR SCHEDULE & DETAILS
A2	PARTIAL SITE PLAN & DETAILS
A6	INTERIOR ELEVATIONS, DETAILS
A7R	PLAN, EXTERIOR ELEVATIONS
A8R	INTERIOR ELEVATIONS, FINISH & PAINT SCHEDULES
A9R	INTERIOR ELEVATIONS
A13	CABINET DETAILS
A14	CABINET DETAILS
A35	DETAILS
S-B1	FOUNDATION PLAN
S-B2	ROOF FRAMING
S3	TYPICAL STRUCTURAL DETAILS
M-4R	MECHANICAL
P-1R	PLOT PLAN & SYMBOLS - PLUMBING
P-4R	FLOOR PLAN - PLUMBING
P-7R	PLUMBING DETAILS
E1R	PLOT PLAN - ELECTRICAL
E4R	ELECTRICAL
A201MD	FLOOR PLAN



**Statement of Structural Tests
and Special Inspections**
2010 CBC

INCREMENT # DSA File No.:
 Application No.:
 Date Submitted: 2/19/2013 Revised:
 Revised:

School Name	MOUNT DIABLO HIGH SCHOOL - BUILDING S MODERNIZATION	District	MOUNT DIABLO UNIFIED SCHOOL DISTRICT
--------------------	--	-----------------	---

IMPORTANT: This form is only a summary list of structural tests and special inspections required for the project. The actual tests and inspections must be performed as detailed on the DSA approved documents. The project inspector is responsible for providing inspection of all facets of construction, including but not limited to, special inspections not listed on this form such as structural wood framing, high-load wood diaphragms, cold-formed steel framing, anchorage of non-structural components, etc., per Title 24, Part 2, Chapter 17A.

NOTE: This form is also available for projects submitted for review under the 2007 CBC.

INSTRUCTIONS: Click a plus sign (+) before any category or subcategory to reveal additional tests and special inspections. An "X" before a listed test or inspection indicates it is a mandatory requirement. A shaded box indicates a test or special inspection that may be required, depending on the scope of the construction and other issues. A shaded box can be checked indicating your selection of that test. **Note:** A minus (-) on a category or subcategory heading indicates that it can be collapsed. However, any selections you may have made will be cleared. Click on the "COMPILE" button to show only the tests finally selected. **For more information on use of this form, see DSA-103.INSTR.**

Note: All references to the California Building Code (CBC) are to the 2010 edition.

	TEST OR SPECIAL INSPECTION	TYPE 1	PERFORMED BY 2	CODE REFERENCE AND NOTES
+	SOILS			
-	CONCRETE			
-	7. CAST IN PLACE CONCRETE			Table 1704A.4
	Material Verification and Testing:			
X	a. Verify use of required design mix.	Periodic	SI & PI*	* To be performed by batch-plant special inspector and project inspector.
X	c. Perform slump, temperature, and (where required) air content tests.	Test	Lab	ASTM C172, ASTM C31.
X	d. Test concrete (compression).	Test	Lab	1905A.6 (1905.6*), ASTM C39.
	Inspection:			
X	e. Inspect batching of concrete.	Continuous	SI	1704A.4.2; (see 1704A.4.3, option 2 for waiver based on design parameters).
X	f. Inspect placement of formwork, reinforcing steel, embedded items and concrete. Inspect curing and form removal.	Continuous	PI*	* May be performed by a special inspector when specifically approved by DSA.
-	11. POST-INSTALLED ANCHORS:			
X	a. Inspect installation of post-installed anchors	Continuous	PI	Table 1704A.4
X	b. Test post-installed anchors.	Test	Lab	1916A.7 (1916.1.11*).
+	MASONRY			Table 1704A.5.3
+	STEEL			Table 1704A.3
+	WOOD			
+	OTHER			Section 1704A.15

EXHIBIT F



Division of the State Architect
CALIFORNIA DEPARTMENT OF GENERAL SERVICES

FORM **DSA-103** rev 5/11

Statement of Structural Tests and Special Inspections
2010 CBC

INCREMENT # DSA File No.:
 Application No.:
 Date Submitted: 2/19/2013 Revised:
 Revised:

- 1 All Structural Testing: Laboratory Verified Report - Form DSA-291
- 2 Concrete Batch Plant Inspection: Special Inspection Verified Report - Form DSA-292

1	Type -	2	Performed By -
Continuous	Indicates that a continuous special inspection is required	GE	Indicates that the special inspection is to be performed by a registered geotechnical engineer or his or her authorized representative
Periodic	Indicates that a periodic special inspection is required	Lab	Indicates that the test is to be performed by a testing laboratory accepted in the DSA Laboratory Evaluation and Acceptance (LEA) Program
Test	Indicates that a test is required	PI	Indicates that the special inspection is to be performed by the project inspector
		SI	Indicates that the special inspection is to be performed by a special inspector
<p>(Note: The difference between "tests" and "special inspections" is addressed in IR 17-4)</p>		<p>(Note that reassignment of responsibility is permitted only with the written approval of DSA)</p>	

COMPILE

PRINT

Brian J. Maytum, AIA

Name of Architect or Engineer in general responsible charge

Stephen H. Pelham, S.E.

Name of Structural Engineer (When structural design has been delegated)

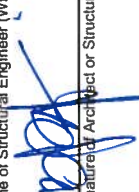
 Signature of Architect or Structural Engineer

date

IDENTIFICATION STAMP
 DIV OF THE STATE ARCHITECT
 APP. # _____
 AC N/A F/LS N/A SS _____
 DATE _____

Architect or Structural Engineer Stamp

DOCUMENT 01 35 13

SPECIAL PROJECT PROCEDURES

1. GENERAL

1.1. RELATED DOCUMENTS AND PROVISIONS

Contractor shall review all Contract Documents for applicable provisions related to the provisions in this document, including without limitation:

- 1.1.1. General Conditions;
- 1.1.2. Special Conditions;
- 1.1.3. Submittals; and
- 1.1.4. Construction Schedule.

2. REQUIREMENTS OF THE DISTRICT

- 2.1. Contractor shall utilize the District's existing Internet/Web-based project management software to track and manage the project.
- 2.2. Use of the project management software will not replace or change any contractual responsibilities of the Contractor or any other project team member.
- 2.3. The Contractor's project team members shall include the Contractor, Contractor's Superintendent, Project Engineer, Scheduler, and Project Manager. Each project team member shall have access to the Internet and an Internet e-mail address in order to communicate with other project team members and the District's Representative. Within fourteen days of receipt of the Notice to Proceed, the Contractor shall provide confirmation of compliance with these conditions and the names, positions, and e-mail addresses of the Contractor's project team members identified in this section to the District.

2.4. SOFTWARE AND HARDWARE REQUIREMENTS

- 2.4.1. Contractor is required to provide, at both the field office and home office location from which this project is managed, computer hardware and software that meet the requirements of Constructware[®] project management software, developed by Emerging Solutions, Inc. of Alpharetta, GA. The Contractor is not required to purchase Constructware[®] software, only the hardware and software required to access this system via the Internet. The District will provide the Contractor a single user license to use the existing project database for the duration of the project. The Contractor shall pay Constructware[®] directly for any additional licenses needed to use the database. Contractor's licenses to the Constructware[®] database will permit access only to this project, in accordance with permission levels configured by the District's Constructware[®] administrator.
- 2.4.2. The District shall provide the Contractor with Constructware[®] training in two increments of four hours each. The anticipated training will take place in either the District's Construction Manager's office or Contractor's main office.
- 2.4.3. The Administrator for this project is the District's Construction Manager.

- 2.4.4. The Contractor shall have Internet access through an Internet service provider of his/her choice
- 2.4.5. Software requirements are as follows:
 - 2.4.5.1. A 32-bit operating system such as Windows 95, 98, NT, 2000 or XP
 - 2.4.5.2. Internet Explorer Version 5.0, Service Pack 2, or above
 - 2.4.5.3. Contractor shall verify these requirements.
- 2.4.6. Hardware requirements:
 - 2.4.6.1. Pentium based (or equivalent) workstation or laptop
 - 2.4.6.2. 32 megs of RAM minimum; ideally 128 megs of RAM
 - 2.4.6.3. A connection to the Internet (28.8 kbps or faster, 56 kbps recommended)
- 2.4.7. More information on Constructware[®] may be obtained via the World Wide Web, at www.constructware.com, or by calling (714) 377-9077

2.5. SYSTEM MANAGEMENT AND USE

- 2.5.1. The District's Construction Manager will administer the Constructware[®] user account.
- 2.5.2. All costs associated with using this system, including computer hardware, software, internet service, and additional licenses beyond the one to use the existing project database are the responsibility of the Contractor.

2.6. USE BY SUBCONTRACTORS

- 2.6.1. The District encourages the Contractor to utilize Constructware[®] project management software for communicating with its subcontractors. The Contractor shall inform all Subcontractors of the purpose of the project management system and how it can assist them in obtaining information for the project.

2.7. COMMUNICATIONS PROCESS

- 2.7.1. The District will outline and detail communication, correspondence and coordination procedures at Project start meeting.
- 2.7.2. Most project communication will take place in the Constructware[®] project management system by creating and distributing documents directly within the system, or by entering manually in the system dates and descriptions of items to track over time. All documents requiring formal signatures will be printed, and their hard copies signed and distributed.
- 2.7.3. The official submittal log will be maintained within Constructware[®]. The Contractor will use the Constructware[®] transmittal format for each submittal transmittal; however, the Contractor will distribute prints, documents, reports, samples, etc. in the traditional manner, outside the system. The Constructware[®] project management system will be used to track and expedite processing of these items.
- 2.7.4. Contractor will be required to utilize modules including but not limited to: Contractor's superintendent's daily reports; meeting minutes; punch lists; requests for information (RFI); Schedule of Values; and correspondence within the Constructware[®] project management system. The Contractor can enter an RFI and the Architect/Engineer respond to the RFI completely within the Constructware[®] project management system without creating a hard copy. Support documentation in hard copy format for any document in Constructware[®] may be scanned into an electronic file and attached in Constructware[®] to documents.
- 2.7.5. The Contractor will use Constructware[®] to create the Payment Applications for each site, print a copy and notarize the document prior to submission.

3. PRODUCTS

3.1. EXTRANET APPLICATION

- 3.1.1. Extranet application service provider shall be the following (no substitution) Constructware[®] as provided by:
Emerging Solutions, Inc.
www.constructware.com

4. EXECUTION

4.1. IMPLEMENTATION

- 4.1.1.** Project Management Application is an Internet-Accessed Centralized Database of project information and consists of several separate modules or master file divisions for ease of organization. Available file divisions include but are not limited to: Correspondence, Daily Reports, RFI's, Transmittals, Submittals, Meetings, Documents, Drawings, Specifications, Punch Lists, Reports, Project Photos, Project Team, Schedule of Values, owner request for proposals, etc.
- 4.1.2.** Contractor shall be provided with a single user license for Constructware[®] (ASP) by the District. The Contractor shall insure that all major project team members on this project have Internet access available during the duration of this project.

END OF DOCUMENT

DOCUMENT 01 35 45

COLLABORATIVE FOR HIGH PERFORMANCE SCHOOLS (CHPS)

SPECIAL ENVIRONMENTAL REQUIREMENTS

1. GENERAL

1.1. RELATED DOCUMENTS AND PROVISION

Contractor shall review all Contract Documents for applicable provisions related to the provisions in this document, including without limitation:

- 1.1.1. General Conditions;
- 1.1.2. Special Conditions;
- 1.1.3. Section 01600: Materials and Equipment; and
- 1.1.4. Section 01800: General Commissioning Requirements.

1.1. SUMMARY

1.1.1. **Special Environmental Requirements:** Work includes special environmental, sustainable, and “green” building practices related to energy conservation and efficiency, indoor air quality, and resource efficiency, including the following:

1.1.1.1. Special Requirements:

- 1.1.1.1.1. Require practices to ensure healthy indoor air quality.
- 1.1.1.1.2. Maximize use of durable Products.
- 1.1.1.1.3. Maximize use of Products easy to maintain, repair, and that can be cleaned using non-toxic substances.
- 1.1.1.1.4. Maximize recycled content in materials, Products, and systems.
- 1.1.1.1.5. Require use of wood that is certified sustainably harvested by the Forest Stewardship Council (FSC).
- 1.1.1.1.6. Maximize use of reusable and recyclable packaging.
- 1.1.1.1.7. Maximize use of Products with low embodied energy (production, manufacturing, and transportation).

1.1.1.2. Contractor is required to comply with sustainable building practices during construction and when considering materials for substitutions..

1.2. DESIGN REQUIREMENTS

- 1.2.1. **General:** District has established general environmental goals for design and construction of Project; Contractor, subcontractors, suppliers, and manufacturers are encouraged to participate where possible to achieve District's environmental goals.
 - 1.2.1.1. Environmental goals should be achieved in manner that ultimately provides safe and healthy environment for building occupants with minimal impact on local, regional and global environment.
 - 1.2.1.2. Contract Documents are not intended to limit alternative means of achieving environmental goals.
 - 1.2.1.2.1. Suggestions from Contractor for implementing goals are encouraged.
- 1.2.2. **Environmental Goals:**
 - 1.2.2.1. Refer to Specifications for more detailed construction requirements related to specific materials and systems.
 - 1.2.2.1.1. **Energy Efficiency (Operations through Project):** Materials and systems are intended to maximize energy efficiency for operation of Project through service life.
 - 1.2.2.1.2. **Indoor Environmental and Air Quality:** Materials are selected and processes specified, such as preconditioning and temporary ventilation, to maximize healthy indoor air quality. Cleaning, surface coating, and renewal or replacement of interior materials should be feasible with lowest practical use of toxic, irritating, or odorous compounds. Ventilation system design, construction, and commissioning ensure adequate outside air supply under all anticipated conditions of use. Documentation of system design assumptions is included in Project Manual to enable District to use and modify the system as required to provide continued assurance of indoor air quality. Additionally, materials are selected to sustain healthy indoor environmental qualities.
 - 1.2.2.1.3. **Resource Efficiency (Project Construction):** Materials and systems are to maximize environmentally-benign construction techniques, including construction waste recycling, reusable delivery packaging, and reusability of selected materials.
- 1.2.3. **Energy Conservation:** Maximize energy conservation strategies in order to reduce life-cycle energy requirements.
 - 1.2.3.1. Reduce undesirable heat gain and heat loss through exterior envelope.
 - 1.2.3.2. Use daylight as the primary lighting source in classrooms and supplement with integrated and energy-efficient electrical lighting systems.
 - 1.2.3.3. Choose equipment with high-end energy performance characteristics, including lighting, HVAC systems, appliances, and office equipment.

1.2.3.4. Where appropriate, use thermal storage strategies such as thermal mass of building or ground to minimize total energy consumption.

1.2.3.5. Design mechanical systems for efficient operation throughout the typical operating range, from minimum to peak load.

1.2.4. **Sustainable Site Planning and Landscape:**

1.2.4.1. Maximize erosion and sedimentation control.

1.2.4.2. Minimize Site disturbance.

1.2.4.3. Maximize planted areas.

1.2.4.4. Reduce heat islands.

1.2.4.5. Where possible, reduce or eliminate light pollution from site lighting.

1.2.4.6. Reduce or eliminate use of pesticides.

1.2.4.7. Rely on indigenous, dry or xeriscape planting. Maintain existing planting on Site to reduce costs.

1.2.4.8. Implement seasonal plant and soil maintenance schedule to maintain healthy soil and landscaping.

1.2.4.9. Maximize use of storm water runoff.

1.2.4.10. Reduce water use with water efficient irrigation systems and local vegetation.

1.2.5. **Durable Materials:**

1.2.5.1. Select materials with longest useful service life.

1.2.5.2. Select materials that deteriorate minimally under installed conditions, exposures, and uses.

1.2.5.3. Select materials with surfaces that require minimal or no refinishing or resurfacing.

1.2.5.4. Select materials with protective coating requirements that do not involve frequent application of toxic or odorous components for materials that require surface renewal or protection

1.2.5.5. Select materials that can be re-used after their service life in this building.

1.2.5.6. Select materials that can be recycled at the end of their useful lives for materials that cannot be re-used.

1.2.6. **Resource Efficient Materials:** Use resource efficient materials; consider energy use over life cycle of material including harvesting, mining, manufacturing, transport, installation, use, operations, recycling and disposal.

- 1.2.6.1. Where possible and allowable, re-use existing Project materials to extent feasible within design concept expressed in Contract Documents.
- 1.2.6.2. Select materials that efficiently use resources such as energy, water, and component materials.
- 1.2.6.3. Use construction practices such as material reduction and dimensional planning that maximize efficient use of resources and materials.
- 1.2.6.4. Provide materials that utilize recycled content to maximum degree possible without being detrimental to product performance or indoor air quality.
- 1.2.6.5. Where possible and feasible, provide for non-destructive removal and re-use of materials after their service life in this building.
- 1.2.6.6. Select materials that use less embodied energy to manufacture.
 - 1.2.6.6.1. Exceptions might include materials that result in net energy conservation during their useful life in building and building's life cycle.
- 1.2.6.7. Select materials that conserve energy during building operations.
- 1.2.6.8. Where possible, select materials harvested and manufactured regionally, within a 500-mile radius of the Project Site.
- 1.2.7. Scarce, Irreplaceable, and Endangered Resources:**
 - 1.2.7.1. Select materials from abundant resources.
 - 1.2.7.1.1. For natural resources, determine abundance based on ratio of removal rate from existing stocks to natural replacement/renewal rate, where this information is available.
 - 1.2.7.1.2. For mineral resources, determine abundance based on ratio of removal rate from terrestrial storage minus amount re-entering commerce through recycling or resource recovery compared to total in terrestrial storage, where this information is available.
 - 1.2.7.2. Select renewable materials, and materials which can be replenished.
 - 1.2.7.3. Select materials that create minimal or no damage to natural habitats and natural environment.
 - 1.2.7.4. Select materials that can be easily refinished, repaired or refurbished to extend their useful life.
- 1.2.8. **Pollution:** Select materials that generate least amount of pollution during mining, manufacturing, transport, installation, use, and disposal.
 - 1.2.8.1. Avoid materials that emit greenhouse gases

- 1.2.8.2. Avoid materials that require energy intensive extraction, manufacturing, processing, transport, installation, maintenance, or removal.
- 1.2.8.3. Avoid materials that contain ozone-depleting chemicals (e.g. CFCs or HCFCs).
- 1.2.8.4. Avoid materials that emit potentially harmful volatile organic chemicals (VOCs).
- 1.2.8.5. Employ construction practices that minimize dust production and combustion by-products.
- 1.2.8.6. Avoid materials that can leach harmful chemicals into ground water; do not allow potentially harmful chemicals to enter sewers or storm drains.
- 1.2.8.7. Protect soil against erosion and topsoil depletion.
- 1.2.8.8. Minimize noise generation during construction; screen mechanical equipment to block noise.
- 1.2.8.9. Select materials that can be reused or recycled and materials with significant percentage of recycled content; conform with or exceed specified Project recycled content percentages for individual materials; avoid materials difficult to recycle.
- 1.2.8.10. Protect natural habitats; restore natural habitats where feasible within scope of Project.

1.2.9. Wood Products:

- 1.2.9.1. Use woods from Forest Stewardship Council (FSC) accredited certified sustainably harvested sources, and verify that the material itself is FSC-certified.
- 1.2.9.2. Composite wood products with high-recycled content, which meet the indoor air quality data requirements, are acceptable.

1.2.10. Water Efficiency:

- 1.2.10.1. Reduce the use of municipally supplied potable water.
- 1.2.10.2. Reduce dependence on municipal storm water system for plumbing fixtures and irrigation. Eliminate irrigation or use micro-irrigation. Use no moisture sensors or clock timers on irrigation systems.
- 1.2.10.3. Maintain natural aquifer conditions.
- 1.2.10.4. Consider roofwater or groundwater collection system.
- 1.2.10.5. Consider graywater collection system for irrigation systems.
- 1.2.10.6. Commission irrigation, graywater, roofwater collection systems. Provide measurement and verification for these systems. Train maintenance staff on performance of all water collection and distribution systems.

1.3. SUBMITTALS

1.3.1. Resource Efficient Product Data:

1.3.1.1. Environmental Issues Data: Submit following information, including manufacturer’s certifications, verifying information, and test data, where Specifications sections require data relating to environmental issues including but not limited to:

- 1.3.1.1.1. Project Recyclability: Submit information to assist District and Contractor in recycling materials involved in shipping, handling, and delivery, and for temporary materials necessary for installation of products.
- 1.3.1.1.2. Recycled Content: Submit information regarding product post industrial recycled and post consumer recycled content.
 - 1.3.1.1.2.1. Use the “Recycled Content Certification Form”, attached as Appendix A to this Section, signed by a corporate office holder (i.e. Chairman of the Board, President, Vice President, Secretary, or similar position of authority).
- 1.3.1.1.3. Product Recyclability: Submit information regarding product and product’s component’s recyclability including potential sources accepting recyclable materials.
- 1.3.1.1.4. Provide certification for all wood products provided by a Forest Stewardship Council (FSC) accredited certifier.
- 1.3.1.1.5. Provide final certification of well-managed forest of origin to provide final documentation of FSC-certified sustainably harvested status: Acceptable wood “certified sustainably harvested” certifications shall include:
 - 1.3.1.1.5.1. Wood suppliers’ certificate issued by one of the Forest Stewardship Council-accredited certifying agencies, such as Smart wood (800-434-5491) or Forest Conservation Program (510-832-1415);
 - 1.3.1.1.5.2. Suppliers’ invoice detailing the quantities of certified wood products for project; and
 - 1.3.1.1.5.3. Letter from one of a certifying agency corroborating that the products on the wood supplier’s invoice originate from FSC-certified well-managed forests.

1.3.2. Indoor Air Quality (IAQ) Data:

1.3.2.1. Environmental Issues: Submit emission test data produced by acceptable testing laboratory listed in Quality Assurance Article for materials as required in each specific Specification section.

- 1.3.2.1.1. Laboratory reports shall contain emissions test data on VOCs including total VOCs (TVOC), specific individual VOCs, formaldehyde and other aldehydes as described in this Specification Section.

- 1.3.2.1.2. In special cases it may be necessary to identify other specific chemicals for listing based on known quantity present or on known odor, irritation or toxicity.
- 1.3.2.1.3. Identify all VOCs emitted by each material as required in these Specifications.
- 1.3.2.1.4. Specific test conditions and requirements are set forth in this Section. For required tests, submit documentation of sample acquisition, handling, and test specimen preparation, as well as test conditions, methods, and procedures. The tests consist of a ten (10) day conditioning period followed by a 96 hour test period.
 - 1.3.2.1.4.1. Samples collected during the test period at 24, 48, and 96 hours shall be analyzed for TVOC and formaldehyde.
 - 1.3.2.1.4.2. VOC samples collected at 96 hours shall be identified and quantified for all compounds that are Chemicals of Concern as indicated herein
- 1.3.2.2. **Cleaning and Maintenance Products:** Provide data on manufacturers' recommended maintenance, cleaning, refinishing and disposal procedures for materials and products. These procedures are for final Contractor cleaning of the Project prior to Completion and for provided materials and products as required by the specific specification sections.
 - 1.3.2.2.1. Where chemical products are recommended for these procedures, provide documentation to indicate that no component present in the cleaning product at more than one percent (1%) of the total mass of the cleaning product is a carcinogen or reproductive toxicant as defined in the lists in this specification section.
 - 1.3.2.2.2. For purposes of reporting, identification of product VOC contents shall not be limited to those regulated under Clean Air Act (CAA) but shall also include compounds exempted from the CAA definition and listing of VOCs.
 - 1.3.2.2.3. California EPA and local air district definitions of VOCs based on CAA are not sufficient as they exempt compounds based on non-reactivity for outdoor air pollution control but still important for indoor air quality.
 - 1.3.2.2.4. Avoid cleaning products containing alpha-pinene, d-limonene or other unsaturated carbon double bond alkenes due to chemical reactions with ozone to form aldehydes, acidic aerosols, and ultra fine particulate matter in indoor air. DGS has published specifications for Environmentally Preferable Janitorial Chemicals and a list of cleaning/maintenance products meeting these specifications. Both are available on the internet at:
<http://www.ciwmb.ca.gov/greenbuilding/Specs/Janitorial.doc> and
<http://www.resd.dgs.ca.gov/BPM/lists.htm>.

1.3.3. Certificates:

1.3.3.1. Environmental Issues Certifications:

- 1.3.3.1.1. Submit documentation certifying accuracy of post-industrial and post-consumer recycled content, and recyclability.
- 1.3.3.1.2. Prior to Completion, submit certificate signed by corporate office holder (i.e. Chairman of the Board, President, Vice President, Secretary, or similar position of authority) of Contractor, subcontractor, supplier, vendor, installer or manufacturer, provided they are primarily responsible for manufacture of product, indicating:
 - 1.3.3.1.2.1. Post-industrial and post-consumer recycled content of materials installed are same as those required by Project requirements;
 - 1.3.3.1.2.2. Product recyclability of materials installed is the same as those required by Project requirements; and
 - 1.3.3.1.2.3. Indoor air quality requirements. Certification shall state products and materials provided are essentially same, and contain essentially same components as products and materials tested.
- 1.3.3.1.3. Comply with requirements specified in Document 01770 – Closeout Procedures.

1.3.4. Closeout Submittals: Submit data relating to environmental issues.

1.3.4.1. Submit environmental product certifications, in two (2) forms:

- 1.3.4.1.1. Two (2) CD-ROMs organized by CSI 16 Division Format.
- 1.3.4.1.2. Four (4) three-ring binders organized by CSI 16 Division Format with Table of Contents and with dividers for each division.

1.4. QUALITY ASSURANCE

1.4.1. Environmental Project Management and Coordination: Contractor to identify one person on Contractor’s staff to be responsible for environmental issues compliance and coordination.

- 1.4.1.1. Experience: Environmental project manager to have experience relating to sustainable building construction.
- 1.4.1.2. Responsibilities: Carefully review Contract Documents for environmental issues, coordinate work of trades, subcontractors, and suppliers; instruct workers relating to environmental issues; and oversee Project Environmental Goals.
- 1.4.1.3. Meetings: Discuss Environmental Goals at following meetings:

- 1.4.1.3.1. Pre-construction meeting.
- 1.4.1.3.2. Pre-installation meetings.
- 1.4.1.3.3. Regularly scheduled job-site meetings.
- 1.4.1.3.4. Special sustainability issues meetings.

1.4.2. Environmental Issues Criteria:

Comply with requirements listed in various Specification sections.

1.4.3. Acceptable Indoor Air Emissions Testing Laboratories:

1.4.3.1. **Berkeley Analytical Associates:** 815 Harbour Way South, Suite 6, Richmond, California 94804; telephone 510.236.2325; fax 510.236.2335; e-mail [berkeleyanalytical@ att.net](mailto:berkeleyanalytical@att.net).

1.4.3.2. **Air Quality Sciences, Inc.:** 1337 Capital Circle, Atlanta, Georgia 30067; telephone 770.933.0638; fax 770.933.0641; e-mail info@aq.com.

1.4.3.3. Other Laboratories:

- 1.4.3.3.1. Selection of testing laboratories shall include assessment of prior experience in conducting indoor source emissions tests.
- 1.4.3.3.2. Many laboratories participate in and are certified by American Industrial Hygiene Association laboratory accreditation program; <http://www.aiha.org/lists.html>.
 - 1.4.3.3.2.1. These laboratories are accredited to do analysis for hazards at levels of concern for industrial workplaces and not necessarily accredited, organized, or able to perform analysis for chemicals and particulate matter at concentrations of concern for indoor air.
- 1.4.3.3.3. The proposed laboratory shall be an independent company or organization not related to manufacturer of product to be tested.
- 1.4.3.3.4. Submit documentation on proposed laboratory for review and approval by District.

1.4.4. Indoor Air Emissions Tests:

- 1.4.4.1. Provide environmental chamber test data from tests based on most recent ASTM Standard. (Refer to ASTM, Annual Book of Standards; <http://www.astm.org>.)
- 1.4.4.2. Tests shall be conducted according to guidance contained in ASTM Standard D5116-97 on material test specimens pre-conditioned in clean air prior to testing.
 - 1.4.4.2.1. Review test specimen collection, documentation, collection, preparation and shipping procedures with testing laboratory prior to preparing and shipping sample.

- 1.4.4.2.2. Test specimens shall be packaged in the normal manner at the factory and shipped directly to testing laboratory by the manufacturer. For materials that are not packaged in convenient consumer units, alternate procedures to preserve the chemical integrity of the specimen are required. Obtain test laboratory procedure sheet covering the handling and shipping of materials. If such information is not provided by the laboratory, then wrap the specimen in a manner that will eliminate direct contact with air or packaging materials other than an inert air barrier such as foil or laboratory grade plastic sheet wrapping material.
- 1.4.4.2.3. **Conditioning:** Condition all test specimens for ten (10) days in clean air. Clean air should be free from the Chemicals of Concern. Hold in clean vessels approximately the size of the test chambers and ventilated at the same air flow rate to be used in the test period. Suspend or place specimens on wire racks so that air freely circulates around all sides during the conditioning period. The air temperature and relative humidity during the conditioning period shall be $23\pm 2^{\circ}\text{C}$ and $50\pm 10\%$ RH. Otherwise, the material must be held in an environmental chamber for the entire period.
- 1.4.4.2.4. For wet-applied products and material assemblies, a realistic test specimen shall be prepared using the substrate material on which it will be applied in the building. Alternately, it may be necessary to use a substrate material that closely simulates the actual building substrate.
- 1.4.4.2.5. For material assemblies (e.g., floor and wall systems where the finish material is placed over a substrate, either with or without the use of adhesives), individual components of the assembly system shall be tested separately. If all components meet the emissions criteria established herein, no further testing shall be required. For assemblies where one component, such as a floor or wall covering adhesive, does not meet the criteria, the assembled system may be tested with specimen preparation following the manufacturer's recommended procedures for application of wet components and assembly of the system. If there is a difference between the manufacturers' recommended procedures and procedures required by the project specifications, the project specifications shall be followed.
- 1.4.4.2.6. Wall and other types of paints shall be tested according to the specifications for the particular material. For example, if two coats are to be applied over a primer coat, then the test specimen shall be prepared accordingly, dried between coats per manufacturer's label instructions, and tested as a complete assembly after required conditioning. The total quantity of paint applied shall be reported based on the weight of the assembly immediately before and after the application of each coat.
- 1.4.4.3. The maximum concentration for any chemical emitted at 96 hours in emissions tests shall not result in a modeled indoor air concentration greater than one half ($\frac{1}{2}$) the chronic inhalation REL concentration of California Office of Environmental Health

Hazard Assessment (OEHHA) Chronic Reference Exposure Limit (REL), with the exception of formaldehyde.

- 1.4.4.4. **Formaldehyde:** No single product shall contribute more than one half (½) the OEHHA staff recommended indoor air limit of 33 µg/m³ (27 ppb) for formaldehyde. The calculated concentration of formaldehyde shall not exceed 16.5 µg/m³. Same modeling procedure as described above shall be used for formaldehyde. This concentration limit shall apply to all building and occupancy types.
- 1.4.4.5. Construction adhesives used in Work shall comply with following requirement: no component present in adhesive at more than one percent (1%) of total mass of adhesive shall be a carcinogen or reproductive toxicant as defined in the Chronic Reference Exposure Levels for organic chemicals with possible indoor sources, based on the California OEHHA list as of December 2008 (The most recent list shall be used for this specification as published <http://www.oehha.ca.gov/air/allrels.html>).
- 1.4.4.6. Provide calculations of modeled concentrations based on emissions test results.
- 1.4.4.6.1. Calculations shall be submitted with all other documentation. This requires the calculation of emission factors based on emissions tests, then application of the emission factors, product loading factors in the building, and building parameters in a steady state mass-balance model. The model assumes zero outdoor concentrations, perfect mixing and no sink effects. Alternatively, follow procedures in the most recent applicable ASTM standards and submit assumptions and calculations.
- 1.4.4.6.2. The concentration of a compound in the building shall be calculated using the following Equation;
- $$\text{Concentration} = \frac{(\text{Emission factor}) * (\text{Loading factor})}{(\text{Air change rate})}$$
- For this equation, the units are: $\mu\text{g}/\text{m}^3 = \frac{(\mu\text{g}/\text{m}^2 \text{ hr}) * (\text{m}^2/\text{m}^3)}{(\text{h}^{-1})}$
- This can be simplified as follows: **Concentration = $\frac{\text{Emission rate}}{\text{Air change rate}}$**
- Note that the weekly average air change rate must be used in the calculations of concentrations of contaminants.
- 1.4.4.6.3. **Calculation of emission rate.** Determine the emission rate by multiplying the emission factor by the amount of the material to be used in the building or air handler zone being evaluated. Multiply the emission factor by the area of the material in the building zone being assessed. Note that in some cases a length or mass may be the appropriate unit for emission factor that must then be multiplied by the length or mass of the emission source.
- 1.4.4.6.4. Provide to the laboratory the total area of the zone being assessed by consulting the Contract Documents or the design engineer, to identify

the total area served by the air handler that serves the area(s) within it where the material will be applied. If the material is used in multiple zones, then calculations shall be made to determine the concentration in the zone with the highest loading ratio of material to volume or material to weekly average minimum air change rate, whichever is greater.

- 1.4.4.6.5. Provide to the laboratory the volume of the space served by the air handler by multiplying the floor area by the floor-to-floor clear height (top of finish floor to bottom of structure of floor above) and multiply by 0.9 (to take account of the portion of the volume that is occupied by solid objects). This value represents the ventilated volume for purposes of the calculations required here.
- 1.4.4.6.6. Determine the air change rate by dividing the volume of outside air introduced into the space per hour by the ventilated volume of the space.
- 1.4.4.6.7. Determine the weekly average air change rate by adding the minimum design air change rate during ventilation system operating hours times the number of hours the system is operated to an assumed air change rate from infiltration during ventilation system non-operational hours times the number of hours the system is off; then divide the total by one hundred sixty-eighty (168), the number of hours in a week. Where no values are available from the Contact Documents, use default values as follows:

1.4.4.6.7.1. Offices:

- 1.4.4.6.7.1.1. Where design data are not available to calculate the weekly average air change rate, the modeling shall assume a weekly average air change rate for office buildings of 0.75 air changes per hour (ach). This "default" office air exchange rate is based on a typical weekly office building fifty-five (55) hour operating schedule and an assumed off-hours air change rate of 0.3 ach (assumed air change rate during normal operating hours is in excess of 1.0 per hour).
- 1.4.4.6.7.1.2. Where specific information is available, the Project specific data should be used to calculate the weekly average air change rate. A default building air change rate of 0.2 per hour during non-HVAC operations should be used.

1.4.4.6.7.2. Schools:

- 1.4.4.6.7.2.1. Modeling shall assume weekly average air change rate for school buildings of 0.9 per hour. This air change rate is based on an assumed forty (40) hours per week of ventilation system operation at 3.0 ach

and one hundred twenty-eight (128) hours per week of 0.2 ach through infiltration.

1.4.4.6.7.2.2. Where specific information is available, the Project specific data should be used to calculate the weekly average air change rate. A default building air exchange rate of 0.2 per hour during non-HVAC operations should be used.

1.4.4.6.7.3. Other building types or occupancy types: Use ASHRAE Standard 62.1 2001 default occupant densities and ventilation rates for hours of operation and 0.2 ach for non operating hours unless actual rates are known in which case the actual rates and hours of operation are to be used.

1.4.4.7. **Environmental Chamber Testing:** Indoor Air Emissions Testing Laboratories may use a range of acceptable loading ratios in order to make use of various size chambers, since these are not standardized across laboratories. Loading ratios ranging from 0.25 m²/m³ to 0.45 m²/m³ will be acceptable.

1.4.4.7.1. For dry products, loading ratios within reasonable limits are not critical for determining emission factors; conditioning of test specimens prior to testing will reduce or eliminate differences that may occur in unconditioned samples due to evaporation-limited emissions and sink effects from adsorption of VOCs during final stages of manufacturing or while in packaging during transport to and storage at the laboratory.

1.4.4.7.2. Higher loading ratios lower expected emission factor; however, the relationship is not linear, especially at higher concentrations. Therefore, where strong formaldehyde (or other chemical) sources are known or expected to be present, loading ratios should be selected to represent a median value for the plausible range of actual building loading ratios.

1.4.4.7.3. Loading ratios used shall be included in test report.

1.4.4.7.4. Contractor shall provide to product manufacturers information on actual quantity of material to be used in Project. The product manufacturers will then forward this information to Indoor Air Emissions Testing Laboratory so loading ratios can be adjusted toward actual loading ratio of Project. However, for most low-emitting materials used in construction, actual loading ratio will not significantly affect emission rates except for strong formaldehyde sources, primarily products using urea-formaldehyde resins.

1.4.4.8. Sample Preparation Requirements:

1.4.4.8.1. Substrates for environmental chamber emissions tests of individual Products or materials (materials tested separately):

1.4.4.8.1.1. Dry solid sheet type products:

- 1.4.4.8.1.1.1. Sheet stainless steel or aluminum tray to provide tight fit at edges and reduce emissions from edge of material specimen. If material does not fit very snugly, then use aluminized, low-emitting, clean room tape to seal edges. Dry fabric type products:
- 1.4.4.8.1.1.2. No substrate necessary.
- 1.4.4.8.1.2. Wet products such as adhesives and sealers:
 - 1.4.4.8.1.2.1. Sheet stainless steel, aluminum, or glass unless product is to be applied to gypsum board or other highly absorbent material. If substrate is a highly absorbent material, use a sample the substrate pre-conditioned for 24 hours to the temperature and humidity of the test chamber.
- 1.4.4.8.1.3. Substrates for specific products:
 - 1.4.4.8.1.3.1. Composite wood products (Section 06400): sample to be suspended or supported in chamber with all edges exposed and no edge masking.
 - 1.4.4.8.1.3.2. Gypsum Board (Section 09260): no substrate (testing required ONLY if recycled content gypsum board or if water resistant types are used).
 - 1.4.4.8.1.3.3. Acoustical Ceiling Panels (Section 09510): no substrate, sample to be suspended or supported in chamber with no edge masking.
 - 1.4.4.8.1.3.4. Resilient flooring (Section 09650): stainless steel tray, fitted tightly so that only the upper surface is exposed. Alternately, cover back of flooring with sheet stainless steel and seal edges with low-VOC emitting aluminized clean room tape so only wear surface of flooring is exposed.
 - 1.4.4.8.1.3.5. Carpet Tile and Broadloom Carpet (Section 09680): stainless steel tray, fitted tightly so that only the upper surface is exposed.
 - 1.4.4.8.1.3.6. Flat and eggshell Paints (Section 09900): 5/8" gypsum board.
 - 1.4.4.8.1.3.7. Semi-gloss paints (Section 09900): Where applied to metal, use sheet stainless steel. Where applied to gypsum board, use gypsum board conditioned as described in subsection c below.

- 1.4.4.8.1.3.8. Joint Sealers (Section 07900): Steel channel 0.64 cm by 0.64 cm by 25.4 cm Channel shall be filled with sealant.
- 1.4.4.8.2. Substrates for environmental chamber emissions tests of assemblies of products or materials (materials tested in an assembly):
 - 1.4.4.8.2.1. Laminates or wood veneers applied with adhesives (Section 06400): Medium density fiberboard (MDF).
 - 1.4.4.8.2.2. Resilient flooring applied with adhesives (Section 09650): Sheet stainless steel or glass plate.
 - 1.4.4.8.2.3. Carpet Tile/Broadloom Carpet applied with adhesives and adhesives (Section 09685/Section 09680): Sheet stainless steel or glass plate.
 - 1.4.4.8.2.4. Wall Coverings applied with adhesives (Section 09700 Series): 5/8" gypsum board. Prior to preparation of the test specimen, Gypsum board substrate shall be pre-conditioned for at least 24 hours at 23 ± 2 oC and $50 \pm 10\%$ RH while ventilated with clean air. [Ventilation rate is not important.]
- 1.4.4.8.3. Protocol for Paint Testing: Preparation and handling of paint test specimen.
 - 1.4.4.8.3.1. Flat and Eggshell Paints:
 - 1.4.4.8.3.1.1. Apply paints to 5/8" thick gypsum board. Hold Gypsum board substrate for at least 24 hours at 23 ± 2 oC and $50 \pm 10\%$ RH while ventilated with clean air. Accurately weigh substrate just prior to painting, mask borders to avoid paint dripping on edges and leave center area for paint. Alternative approaches to protecting the edges are acceptable and shall be reported if used.
 - 1.4.4.8.3.1.2. Apply paint using standardized roller procedure that simulates application of paint in building. For most wall paint applications use a 4" wide 3/8" nap roller intended for smooth surfaces.
 - 1.4.4.8.3.1.3. Stir paint in container and transfer 100 mL of paint to heavy-duty aluminum foil disposable tray.
 - 1.4.4.8.3.1.4. Saturate roller cover with paint by running back and forth in tray.
 - 1.4.4.8.3.1.5. Apply paint to substrate using four strokes, two in vertical direction and two in horizontal direction, so entire area is uniformly covered.

- 1.4.4.8.3.1.6. Remove tape from substrate and re-weigh substrate.
- 1.4.4.8.3.1.7. Difference in weight determines amount of applied paint and coverage in grams of wet paint per square meter of substrate surface.
- 1.4.4.8.3.1.8. Place substrate on 6" by 6" piece of sheet stainless steel to cover entirely the back surface. Attach substrate to stainless steel with strips of low VOC aluminized clean room tape so only painted surface is exposed. For a blank specimen, similarly prepare an unpainted piece of gypsum. Alternate procedures to cover unpainted surfaces of gypsum board may be used and must be adequately described in the laboratory report if used.
- 1.4.4.8.3.1.9. Place sample in conditioning environment immediately and hold for ten (10) days.
- 1.4.4.8.3.1.10. Where multiple coats, which may include primer, are being tested, apply paints and follow manufacturers' instructions for drying time between coats. Report weight of test specimen prior to and after each coat of paint is applied. Hold specimen in conditioning environment between coats. The ten (10) day conditioning period begins after application of final coat. Apply semi-gloss paint to clean steel sheet following same procedure as above for "flat and eggshell paints." No tape should be used. Sheet should be weighed immediately before and after painting.

1.4.4.9. Chemical Analyses:

- 1.4.4.9.1. VOC Analysis: Make multi-point calibrations using pure compounds whenever such compounds are available from commercial suppliers (such as Aldrich Chemical Company, Sigma Aldrich). Quantitative analyses performed using surrogate compounds shall be indicated in reported test results. Identify EPA and ASTM standard methods and practices, and testing laboratory calibration procedures, which should include a calibration at least once every three (3) months.
- 1.4.4.9.2. Formaldehyde and Acetaldehyde Analysis: Formaldehyde and Acetaldehyde analysis shall be performed following ASTM Standard D 5197-09e1 "Standard Test Method for Formaldehyde and other Carbonyl Compounds in Air (Active Sampler Methodology)."
- 1.4.4.10. **Reporting Requirements:** In addition to reporting requirement stated elsewhere in Specifications, reports shall include: (a) all compounds emitted from sample that are on the most recent Chronic Reference Exposure Level- Air Toxicology and Epidemiology list as published by the California Office of Environmental Health Hazard Assessment and listed in their website at http://www.oehha.org/air/chronic_rels/allChrels.html, (b) all

compounds on the California Proposition 65 list (http://www.oehha.ca.gov/prop65/prop65_list/files/P65single111811.pdf), and (c) all compounds on the California Toxic Air Contaminant list (<http://www.arb.ca.gov/toxics/catable.htm>). In addition, the ten (10) most abundant compounds shall be reported separately if not listed on any of these lists. For these compounds, report following:

- 1.4.4.10.1. Measured chamber concentrations at each required time point;
- 1.4.4.10.2. Calculated emission factors; and
- 1.4.4.10.3. Calculated building concentrations and assumptions used to make calculation.

1.4.5. State Agency Buy Recycled Campaign (SABRC) Recycled Content (<http://www.calrecycle.ca.gov/BuyRecycled/StateAgency/>): Implement the SABRC recycled-content goals for specific building Products, including but not limited to:

- 1.4.5.1. Paper products;
- 1.4.5.2. Glass products (windows, glazing, fiberglass, tile, construction blocks, loose-grain abrasives);
- 1.4.5.3. Plastic products (carpet, plastic lumber, furniture made from plastic, fencing, parking bumpers, toilet partitions, entry mats, signage, sheet plastic and other plastic-containing building products);
- 1.4.5.4. Solvents;
- 1.4.5.5. Tire-derived products (entry-mats, resilient flooring, wheelchair and other ramps, playground surfacing, parking bumpers, speed bumps, tree ties, road surfacing);
- 1.4.5.6. Steel products (structural steel, steel framing, architectural metal, reinforcing bars, sheet metal, metal siding, metal roofing, lockers, toilet partitions, office furniture for filing and storage);
- 1.4.5.7. Paint (allowed only in exterior installations); and
- 1.4.5.8. Compost.

1.5. DELIVERY, STORAGE, AND HANDLING

- 1.5.1. Packaging: Deliver materials in recyclable or in reusable packaging such as cardboard, wood, paper, or reusable blankets, which will be reclaimed by supplier or manufacturer for recycling.
 - 1.5.1.1. General: Minimize packaging materials to maximum extent possible while still ensuring protection of materials during delivery, storage, and handling.
 - 1.5.1.1.1. Unacceptable Packaging Materials: Polyurethane, polyisocyanate, polystyrene, polyethylene, and similar plastic materials such as “foam” plastics and “shrink-fit” plastics.

- 1.5.1.2. Reusable Blankets: Deliver and store materials in reusable blankets and mats reclaimed by manufacturers or suppliers for reuse where program exists or where program can be developed for such reuse.
- 1.5.1.3. Pallets: Where pallets are used, suppliers shall be responsible to ensure pallets are removed from Site for reuse or for recycling.
- 1.5.1.4. Corrugated Cardboard and Paper: Where paper products are used, recycle as part of construction waste management recycling program, or return to material's manufacturer for use by manufacturer or supplier.
- 1.5.1.5. Sealants, Paint, Primers, Adhesives, and Coating Containers: Return to supplier or manufacturer for reuse where such program is available.

1.6. PROJECT CONDITIONS

1.6.1. Certifications:

1.6.1.1. Environmental Product Certification:

- 1.6.1.1.1. Include manufacturer certification indicating product contains maximum recycled content possible without being detrimental to product performance.
- 1.6.1.1.2. Include certification indicating cleaning materials comply with requirements of these Specifications.

1.6.2. Construction Ventilation and Preconditioning:

- 1.6.2.1. Temporary Construction Ventilation: Maintain sufficient temporary ventilation of areas where materials are being used that emit VOCs. Maintain ventilation continuously during installation, and until emissions dissipate after installation. If continuous ventilation is not possible via building's HVAC system(s) then ventilation shall be supplied via open windows and temporary fans, sufficient to provide no less than three air changes per hour.
 - 1.6.2.1.1. Period after installation shall be sufficient to dissipate odors and elevated concentrations of VOCs. Where no specific period is stated in these Specifications, a time period of 72 hours shall be used.
 - 1.6.2.1.2. Ventilate areas directly to outside; ventilation to other enclosed areas is not acceptable.
- 1.6.2.2. During dust producing activities (e.g. drywall installation and finishing) turn ventilation system off, and openings in supply and return HVAC system shall be protected from dust infiltration. Provide temporary ventilation as required.
- 1.6.2.3. Preconditioning: Prior to installation, allow products which have odors and significant VOC emissions to off-gas in dry, well-ventilated space for fourteen (14) calendar days to allow for reasonable dissipation of odors and emissions prior to delivery to Project site.

- 1.6.2.3.1. Condition Products without containers and packaging to maximize off-gassing of VOCs
- 1.6.2.3.2. Condition Products in ventilated warehouse or other building. Comply with substitution requirements for consideration of other locations.

1.6.3. Protection:

- 1.6.3.1. Moisture Stains: Materials with evidence of moisture damage, including stains, are not acceptable, including both stored and installed materials; immediately remove from Site and properly dispose. Take special care to prevent accumulation of moisture on installed materials and within packaging during delivery, storage, and handling to prevent development of molds and mildew on packaging and on Products.
 - 1.6.3.1.1. Immediately remove from Site and properly dispose of materials showing signs of mold and signs of mildew, including materials with moisture stains.
 - 1.6.3.1.2. Replace moldy materials with new, undamaged materials.
- 1.6.3.2. Ducts: Seal ducts during transportation, delivery, and construction to prevent accumulation of construction dust and construction debris inside ducts.

1.7. SEQUENCING

- 1.7.1. Environmental Issues:
 - 1.7.1.1. On-Site Application: Where odorous and/or high VOC emitting Products are applied on-site, apply prior to installation of porous and fibrous materials. Where this is not possible, protect porous materials with polyethylene vapor retarders.
 - 1.7.1.2. Complete interior finish material installation no less than fourteen (14) days prior to Completion to allow for building flush out.

2. PRODUCTS

2.1. CHEMICALS OF CONCERN

- 2.1.1. **Chemicals of Concern:** Chemicals listed below as toxic air contaminants, carcinogens, teratogens, reproductive toxins, and chemicals with established Chronic Reference Exposure Levels (REL).
- 2.1.2. **Carcinogens:** Chemicals listed as probable or known human carcinogens in the latest published edition of the following two (2) lists:
 - 2.1.2.1. California Environmental Protection Agency, Air Resources Board (ARB), list of Toxic Air Contaminants (California Air Toxics): <http://www.arb.ca.gov/toxics/id/taclist.htm>
 - 2.1.2.2. California Environmental Protection Agency, Office of Environmental Health Hazard Assessment (OEHHA), Safe Drinking Water and Toxic Enforcement Act of 1986 (Proposition 65): http://www.oehha.ca.gov/prop65/prop65_list/Newlist.html.

- 2.1.3. **Reproductive Toxicants:** Chemicals known to cause reproductive toxicity including birth defects or other reproductive harm in the latest published edition of the following list:
 - 2.1.3.1. California Environmental Protection Agency, Office of Environmental Health Hazard Assessment (OEHHA), Safe Drinking Water and Toxic Enforcement Act of 1986 (Proposition 65):
http://www.oehha.ca.gov/prop65/prop65_list/files/P65single111811.pdf.
- 2.1.4. **Chemicals with established Chronic Reference Exposure Levels (REL):** Chronic RELs have been developed for hazardous airborne substances as of December 2008. A chronic REL is an airborne concentration level that would pose no significant health risk to individuals indefinitely exposed to that level. RELs are based solely on health considerations, and are developed from the best available data in the scientific literature. The California Environmental Protection Agency, Office of Environmental Health Hazard Assessment (OEHHA) establishes and publishes RELs. The most recent list shall be used for this Specification as published at
http://www.oehha.ca.gov/air/hot_spots/pdf/CPFs042909.pdf.

2.2. SUBSTITUTIONS

- 2.2.1. Substitutions Environmental Issues: Requests for substitutions shall comply with requirements specified in the Contract Documents and with the following additional information required where environmental issues are specified:
 - 2.2.1.1. Indicate each proposed substitution complies with requirements for VOCs;
 - 2.2.1.2. District reserves the right to reject proposed substitutions where data for VOCs is not provided or where emissions of individual VOCs are higher than for specified Products; and
 - 2.2.1.3. Comply with specified recycled content and other environmental requirements.

3. EXECUTION

3.1. FIELD QUALITY CONTROL

- 3.1.1. Building Flush Out: Just prior to Completion, flush out building continuously (i.e. 24 hours per day, seven (7) days a week) using maximum tempered outside air (or maximum amount of outside air while achieving reasonable indoor temperature) for at least fourteen (14) calendar days. If interruptions of more than a few hours are required for testing and balancing purposes, extend flush out period accordingly.
 - 3.1.1.1. When Contractor is required to perform touch-up work, provide temporary construction ventilation during installation and extend building flush-out by a minimum of four (4) days after touch-up installation with maximum tempered outside air for 24 hour per day.
 - 3.1.1.2. If construction schedule permits, extend flush-out period beyond fifteen (15) days.
 - 3.1.1.3. Return ventilation system to normal operation following flush-out period to minimize energy consumption.

3.2. CLEANING

3.2.1. Final Cleaning Environmental Issues:

- 3.2.1.1. Clean interior and exterior surfaces exposed to view; remove temporary labels, stains, and foreign substances; polish transparent and glossy surfaces using cleaning and maintenance products as described in Part 1 of this Section.
- 3.2.1.2. Clean equipment and fixtures to sanitary condition using cleaning and maintenance products as described in Part 1 of this Document.
- 3.2.1.3. Vacuum carpeted and soft surfaces with high efficiency particulate arrestor (HEPA) vacuum.
- 3.2.1.4. If ducts were not sealed during construction, and contain dust or dirt, clean ducts using HEPA vacuum immediately prior to Completion and prior to using ducts to circulate air. Oil film on sheet metal shall be removed before shipment to Site. However, ducts shall be inspected to confirm that no oil film is present. If present, remove oil.
- 3.2.1.5. Replace all air filters (i.e., pre and final filters) just prior to Completion.
- 3.2.1.6. Remove and properly dispose of recyclable materials using construction waste management program described in the Specifications.

3.3. PROTECTION

3.3.1. Environmental Issues:

- 3.3.1.1. Protect interior materials from water intrusion or penetration; where interior Products not intended for wet applications are exposed to moisture, immediately remove from Site and dispose of properly.
- 3.3.1.2. Protect installed Products using methods that do not support growth of molds and mildews.
 - 3.3.1.2.1. Immediately remove from Site Products with mold or mildew.

END OF DOCUMENT

Project Name: _____

RECYCLED CONTENT CERTIFICATION FORM

This form is to be completed by a Corporate Officer of the Product Manufacturer for the General Contractor. Contractor must return the certification, completed for each product with recycled content as required by Specifications. Attach additional sheets if necessary.

CONTRACTOR Name: Address: Telephone, fax, e-mail:	SUBCONTRACTOR/INSTALLER Name: Address: Telephone, fax, e-mail:	PRODUCT MANUFACTURER Name: Address: Telephone, fax, e-mail:
---	--	---

Item #	Product Category ^{1&2} (Include if applicable)	Product Description ³ (Needed for all products)	Quantity Bid	Unit of measure	Cost of material, (Excluding installation labor)	Weight in pounds	% Virgin Content ⁵	% Post-consumer ⁶	% Post-industrial ⁷	Total % ⁸
		CSI section:					As a percent of total weight			
		CSI section:								100
		CSI section:								100
		CSI section:								100
		CSI section:								100
		CSI section:								100
		CSI section:								100

Printed Name: (a corporate officer) _____ Title _____ Date _____ Signature _____

APPENDIX A

THE COLLABORATIVE FOR HIGH PERFORMANCE SCHOOLS

GENERAL NOTES:

- A. The Public Contract Code Sections, listed below, apply to California public (DGS) projects only. The required document has been adapted for use on other types of projects, including public schools.
- B. Public Contract Code Sections 10233, 10308.5, and 10354 require all vendors and contractors to certify in writing, under penalty of perjury, to the state agency awarding a contract, the minimum, if not the exact percentage, of post-consumer and post-industrial material in the materials, goods, or supplies offered or used.
- C. Public Contract Code Section 12205(a) requires all state agencies to require all contractors to certify in writing, under penalty of perjury, the minimum, if not the exact percentage, of post-consumer and post-industrial material in the materials, goods, or services provided or used.

NOTES:

(1) Product Category: (Fill in above, if applicable. This information is used to determine compliance with the State Agency Buy Recycled Campaign.)

- | | | | |
|----|--------------------|-----|-----------------------------|
| 1. | Compost/Co-compost | 7. | Printing and Writing Papers |
| 2. | Glass Products | 8. | Solvents |
| 3. | Lubricating Oils | 9. | Steel Products |
| 4. | Paint | 10. | Tires |
| 5. | Plastic Products | 11. | Tire-derived Products |
| 6. | Paper Products | | |

(2) Product category is used for State agency reporting for State projects, excluding public schools. Products that are made from multiple material types should be reported in the product category of the material type representing most of the product. The amount of material used in the product can be measured by weight or volume. If, for instance, a chair is made from steel, aluminum, and plastic and most of the material, either by weight or volume, is plastic, report it as a plastic product. If, however, most of the product, either by weight or volume, is steel, report the purchase as a steel product.

(3) Identify the Construction Specifications Institute (CSI) Specification Section number for the product, as indicated in the Project Specifications.

(4) Below are products preliminarily identified in the Project Specifications as having minimum recycled content requirements. Refer to the Project Specifications for individual sections in the specifications for recycled content level that must be achieved. Recycled content guidelines shall include, but not be limited to, the products below (to be revised for each project):

- | | | | |
|----|--|-----|--|
| 1. | Parking Bumpers
(Section 2760) | 7. | Building Insulation
(Section 07210) |
| 2. | Fluid-Applied Waterproofing
(Section 07140) | 8. | Steel doors and frames
(Section 08110) |
| 3. | Concrete reinforcement
(Section 03200) | 9. | Glazing
(Section 08800) |
| 4. | Bentonite Waterproofing
(Section 07170) | 10. | Paints and Coatings
(Section 09900) |
| 5. | Structural steel
(Section 05120) | 11. | Cold-Formed Metal Framing
(Section 05400) |
| 6. | Metal Decking | | |

- 12. Gypsum board
(Sections 09255, 09260, 09265)
- 13. Ceramic tile
(Section 09300)
- 14. Acoustical ceilings
(Section 09510)
- 15. Resilient flooring
(Section 09650)

- 16. Carpeting
(Sections 09682, 09686)
- 17. Metal Toilet Compartments
(Section 10160)
- 18. Identifying Devices
(Section 10400)
- 19. Architectural Woodwork
(Section 06400)

- (5) Virgin material content is that portion of the product made from non-recycled material, that is, the material is neither post-industrial nor post-consumer material.
- (6) Post-consumer material is defined as "a finished material which would have been disposed of as a solid waste, having completed its life cycle as a consumer item, and does not include manufacturing wastes." This is material such as a newspaper that is read, recycled and then made into recycled content newsprint or some other recycled product. Post-consumer material is generally any product that is bought by the consumer, used, and then recycled into another product.
- (7) Post-industrial (also referred to as pre-consumer or secondary material) is defined as "fragments of finished products or finished products of a manufacturing process, which has converted a resource into a commodity of real economic value, but does not include excess virgin resources of the manufacturing process." This is material such as newsprint that is trimmed from a roll in the paper plant that is returned to the beginning of the process to make recycled content newsprint. The material (product) did not get to the consumer before being recycled. Post-industrial material DOES NOT include post-consumer material. FOR EXAMPLE: If a Printing and Writing Paper contained 20% post-consumer material, you would indicate 20 in the post-consumer column and 80 in the virgin consumer column. If the product had 40% secondary material and 20% post-consumer material, you would indicate 40 in the post-industrial column, 20 in the post-consumer column, and 40 in the virgin column.
- (8) The sum of the percentages for virgin, post-consumer, and post-industrial content must equal 100 percent.

DOCUMENT 01 41 00

REGULATORY REQUIREMENTS

1. GENERAL

1.1. RELATED DOCUMENTS AND PROVISIONS

Contractor shall review all Contract Documents for applicable provisions related to the provisions in this document, including without limitation:

- 1.1.1. General Conditions, including, without limitation, Obtaining of Permits and Licenses and Work to Comply with All Applicable Regulations;
- 1.1.2. Special Conditions; and
- 1.1.3. Quality Control.

1.2. DESCRIPTION

This section covers the general requirements for regulatory requirements pertaining to the Work and is supplementary to all other regulatory requirements mentioned or referenced elsewhere in the Contract Documents.

1.3. REQUIREMENTS OF REGULATORY AGENCIES

- 1.3.1. All statutes, ordinances, laws, rules, codes, regulations, standards, and the lawful orders of all public authorities having jurisdiction of the Work, are hereby incorporated into the Contract Documents as if repeated in full herein and are intended to be included in any reference to Code or Building Code, unless otherwise specified, including, without limitation, the references in the list below. Contractor shall make available at the Site copies of all the listed documents applicable to the Work as the District and/or Architect may request, including, without limitation, applicable portions of the California Code of Regulations (C.C.R.).
- 1.3.2. This Project shall be governed by applicable regulations, including, without limitation, the State of California's Administrative Regulations for the Division of the State Architect-Structural Safety (DSA/SS), Chapter 4, Part 1, Title 24, C.C.R., and the most current version on the date the bids are opened and as it pertains to school construction including, without limitation:
 - 1.3.2.1. Test and testing laboratory pursuant to Section 4-335 (District shall pay for the testing laboratory).
 - 1.3.2.2. All special inspections pursuant to Section 4-333(d).
 - 1.3.2.3. Contractor shall submit verified reports pursuant to Section 4-336 & 4-343(c).
 - 1.3.2.4. Administration
 - 1.3.2.4.1. Duties of the Architect and Engineers shall be pursuant to Section and 4-341.

- 1.3.2.4.2. Duties of Contractor shall be pursuant Section 4-343.
- 1.3.2.4.3. Verified Reports shall be pursuant to Section 4-336.
- 1.3.2.5. Contractor shall keep and make available a copy of Part 1 and 2 of the most current version of C.C.R., Title 24 at the Site during construction.
- 1.3.2.6. Contractor shall notify the Division of State Architect (DSA) upon the start of construction pursuant to Section 4-331.
- 1.3.2.7. Addenda and Change Orders shall be pursuant to Section 4-338.
- 1.3.3. Items of deferred approval shall be clearly marked on the first sheet of the Architect's and/or Engineer's approved Drawings. All items later submitted for approval shall be pursuant to Title 24 requirements to the DSA.
 - 1.3.3.1. Building Standards Administrative Code, C.C.R., Title 24, Part 1..
 - 1.3.3.2. California Building Code (CBC), C.C.R., Title 24, Part 2.; (Uniform Building code volumes 1-3 and California Amendments).
 - 1.3.3.3. California Electrical Code (CEC), C.C.R., Title 24, Part 3 ; (National Electrical Code and California Amendments).
 - 1.3.3.4. California Mechanical Code (CMC), C.C.R., Title 24, Part 4 ; (Uniform Mechanical Code and California Amendments).
 - 1.3.3.5. California Plumbing Code (CPC), C.C.R., Title 24, Part 5; (Uniform Plumbing Code and California Amendments).
 - 1.3.3.6. California Fire Code (CFC), C.C.R., Title 24, Part 9; (Fire Plumbing Code and California Amendments).
 - 1.3.3.7. California Referenced Standards Code, C.C.R., Title 24, Part 12.
 - 1.3.3.8. State Fire Marshal Regulations, C.C.R., Title 19, Public Safety.
 - 1.3.3.9. Partial List of Applicable NFPA Standards:
 - 1.3.3.9.1. NFPA 13 - Automatic Sprinkler System.
 - 1.3.3.9.2. NFPA 14 - Standpipes Systems.
 - 1.3.3.9.3. NFPA 17A - Wet Chemical System
 - 1.3.3.9.4. NFPA 24 - Private Fire Mains.
 - 1.3.3.9.5. (California Amended) NFPA 72 - National Fire Alarm Codes.
 - 1.3.3.9.6. NFPA 253 - Critical Radiant Flux of Floor Covering System.
 - 1.3.3.9.7. FPA 2001 - Clean Agent Fire Extinguishing Systems.
 - 1.3.3.10. California Division of the State Architect Interpretation of Regulations Manual.

END OF DOCUMENT

DOCUMENT 01 42 13

ABBREVIATIONS AND ACRONYMS

1. GENERAL

1.1. RELATED DOCUMENTS AND PROVISIONS

Contractor shall review all Contract Documents for applicable provisions related to the provisions in this document, including without limitation:

- 1.1.1. General Conditions including without limitation, Contract Terms and Definitions; and
- 1.1.2. Special Conditions.

1.2. DOCUMENT INCLUDES

- 1.2.1. Abbreviations and Acronyms for Standards and Regulations used throughout the Contract Documents shall mean the recognized name of the standards and regulations indicated in
 - 1.2.1.1. Thomson Gale, Gale Research's "Encyclopedia of Associations: National Organizations of the U.S." or
 - 1.2.1.2. Columbia Books' "National Trade & Professional Associations of the U.S."
- 1.2.2. Some of the applicable abbreviations and acronyms have the following meanings, subject to updates or revisions based on the above-referenced publications:

- AA: Aluminum Association
- AAMA: Architectural Aluminum Manufacturers Association
- AASHTO: American Association of State Highway and Transportation Officials
- ABPA: Acoustical and Board Products Association
- ACI: American Concrete Institute
- AGA: American Gas Association
- AGC: Associated General Contractors
- AHC: Architectural Hardware Consultant
- AI: Asphalt Institute
- AIA: American Institute of Architects
- AIEE: American Institute of Electrical Engineers
- AISC: American Institute of Steel Construction
- AISI: American Iron and Steel Institute
- AMCA: Air Moving and Conditioning Association
- ANSI: American National Standards Institute
- APA: American Plywood Association
- ARI: Air Conditioning and Refrigeration Institute
- ASHRAE: American Society of Heating, Refrigeration and Air Conditioning Engineers
- ASME: American Society of Mechanical Engineers
- ASSE: American Society of Structural Engineers
- ASTM: American Society of Testing and Materials

- AWPB: American Wood Preservers Bureau
- AWPI: American Wood preservers Institute
- AWS: American Welding Society
- AWSC: American Welding Society Code
- AWI: Architectural Woodwork Institute
- AWWA: American Water Works Association
- BIA: Brick Institute of America
- CCR: California Code of Regulations
- CLFMI: Chain Link Fence Manufacturers Institute
- CMG: California Masonry Guild
- CRA: California Redwood Association
- CRSI: Concrete Reinforcing Steel Institute
- CS: Commercial Standards
- CSI: Construction Specifications Institute
- CTI: Cooling Tower Institute
- FGMA: Flat Glass Manufacturer’s Association
- FIA: Factory Insurance Association
- FM: Factory Mutual
- FS: Federal Specification
- FTI: Facing Title Institute
- GA: Gypsum Association
- ICC: International Code Council
- IEEE: Institute of Electrical and Electronic Engineers
- IES: Illumination Engineering Society
- LIA: Lead Industries Association
- MIA: Marble Institute of America
- MLMA: Metal Lath Manufacturers Association
- MS: Military Specifications
- NAAMM: National Association of Architectural Metal Manufacturers
- NBHA: National Builders Hardware Association
- NBFU: National Board of Fire Underwriters
- NBS: National Bureau of Standards
- NCMA: National Concrete Masonry Association
- NEC: National Electrical Code
- NEMA: National Electrical Manufacturers Association
- NFPA: National Fire Protection Association/National Forest Products Association
- NMWIA: National Mineral Wool Insulation Association
- NTMA: National Terrazzo and Mosaic Association
- NWMA: National Woodwork Manufacturer’s Association
- ORS: Office of Regulatory Services (California)
- OSHA: Occupational Safety and Health Act
- PCI: Precast Concrete Institute
- PCA: Portland Cement Association
- PDCA: Painting and Decorating Contractors of America
- PDI: Plumbing Drainage Institute
- PEI: Porcelain Enamel Institute
- PG&E: Pacific Gas & Electric Company
- PS: Product Standards
- SDI: Steel Door Institute; Steel Deck Institute

- SJI: Steel Joist Institute
- SSPC: Steel Structures Painting Council
- TCA: Tile Council of America
- TPI: Truss Plate Institute
- UBC: Uniform Building Code
- UL: Underwriters Laboratories Code
- UMC: Uniform Mechanical Code
- USDA: United States Department of Agriculture
- VI: Vermiculite Institute
- WCLA: West Coast Lumberman's Association
- WCLB: West Coast Lumber Bureau
- WEUSER: Western Electric Utilities Service Engineering Requirements
- WIC: Woodwork Institute of California
- WPOA: Western Plumbing Officials Association

END OF DOCUMENT

DOCUMENT 01 42 16

GENERAL DEFINITIONS AND REFERENCES

1. GENERAL

1.1. RELATED DOCUMENTS AND PROVISION

Contractor shall review all Contract Documents for applicable provisions related to the provisions in this document, including without limitation:

- 1.1.1. General Conditions including without limitation, Contract Terms and Definitions;
- 1.1.2. Special Conditions.

1.2. QUALITY ASSURANCE

- 1.2.1. For products or workmanship specified by association, trade, or Federal Standards, Contractor shall comply with requirements of the standard, except when more stringent requirements are specified in the Contract Documents, or are required by applicable codes.
- 1.2.2. Contractor shall conform to current reference standard publication in effect on the date of bid opening.
- 1.2.3. Unless directed otherwise by the Contract Documents, Contractor shall obtain copies of referenced standards.
- 1.2.4. Unless directed otherwise by the Contract Documents, Contractor shall maintain a copy of referenced standards at jobsite until Completion.
- 1.2.5. If specified standards conflict with Contract Documents, Contractor shall request clarification from the District or the Architect before proceeding.
- 1.2.6. Governing Codes shall be as shown in the Contract Documents including, without limitation, the Specifications.

1.3. SCHEDULE OF REFERENCES

The following information is intended only for the general assistance of Contractor. District does not represent the accuracy of the information. Contractor shall independently verify the information for each entities listed below:

AA	Aluminum Association 900 19th Street NW, Suite 300 Washington, DC 20006 www.aluminum.org	202/862-5100
AABC	Associated Air Balance Council 1518 K Street, NW, Suite 503 Washington, DC 20005 www.aabchg.com	202/737-0202

AAMA	American Architectural Manufacturers Association 1827 Walden Office Sq., Suite 104 Schaumburg, IL 60173-4268 www.aamanet.org	847/303-5664
AASHTO	American Association of State Highway and Transportation Officials 444 North Capitol Street, Suite 249 Washington, DC 20001 www.aashto.org	202/624-5800
AATCC	American Association of Textile Chemists and Colorists P.O. Box 12215 One Davis Drive Research Triangle Park, NC 27709-2215 www.aatcc.org	919/549-8141
ACI	American Concrete Institute P.O. Box 9094 Farmington Hills, MI 48333-9094 www.aci-int.org	248/848-3700
ACPA	American Concrete Pipe Association 222 West Las Colinas Blvd., Suite 641 Irving, TX 75039-5423 www.concrete-pipe.org	972/506-7216
ADC	Air Diffusion Council 11 South LaSalle St., Suite 1400 Chicago, IL 60603 http://www.flexibleduct.org/index.asp	312/201-0101
AFPA	American Forest and Paper Association 1111 19th St., NW, Suite 800 Washington, DC 20036 http://www.afandpa.org/	202/463-2700
AGA	American Gas Association 1515 Wilson Blvd. Arlington VA 22209 www.aga.com	703/841-8400
AHA	American Hardboard Association 1210 W. Northwest Hwy Palatine, IL 60067-1897 http://domensino.com/AHA/default.htm	847/934-8800

AI	Asphalt Institute Research Park Drive P.O. Box 14052 Lexington, KY 40512-4052 www.asphaltinstitute.org	606/288-4960
AIA	The American Institute of Architects 1735 New York Avenue, NW Washington, DC 20006-5292 www.aia.org	202/626-7300
AISC	American Institute of Steel Construction One East Wacker Drive, Suite 3100 Chicago, IL 60601-2001 http://www.aisc.org/	800/644-2400
AITC	American Institute of Timber Construction 7012 S. Revere Pkwy., Suite 140 Englewood, CO 80112 www.aitc-glulam.org	303/792-9559
ALCA	Associated Landscape Contractors of America 12200 Sunrise Valley Drive, Suite 150 Reston, VA 20191 www.alca.org	703/620-6363
ALI	Associated Laboratories, Inc. P.O. Box 152837 1323 Wall St. Dallas, TX 75315 http://www.assoc-labs.com/	214/565-0593
ALSC	American Lumber Standards Committee P.O. Box 210 Germantown, MD 20875	301/972-1700
AMCA	Air Movement and Control Association International, Inc. 30 W. University Drive Arlington Heights, IL 60004-1893 www.amca.org	847/394-0150
ANLA	American Nursery and Landscape Association 1250 Eye Street, NW, Suite 500 Washington, DC 20005	202/789-2900
ANSI	American National Standards Institute 11 West 42nd Street, 13th Floor New York, NY 10036-8002 www.ansi.org	212/642-4900
APA	APA-The Engineered Wood Association P.O. Box 11700	206/565-6600

	Tacoma, WA 98411-0700 www.apawood.org	
APA	Architectural Precast Association P.O. Box 08669 Fort Myers, FL 33908-0669	941/454-6989
ARI	Air Conditioning and Refrigeration Institute 4301 Fairfax Drive, Suite 425 Arlington, VA 22203 www.ari.org	703/524-8800
ARMA	Asphalt Roofing Manufacturers Association Center Park 4041 Powder Mill Road, Suite 404 Calverton, MD 20705	301/231-9050
ASA	Acoustical Society of America 500 Sunnyside Blvd. Woodbury, NY 11797	516/576-2360
ASCE	American Society of Civil Engineers- World Headquarters 1801 Alexander Bell Drive Reston, VA 20190-4400 www.asce.org	800/548-2723 703/295-6000
ASHRAE	American Society of Heating, Refrigerating and Air Conditioning Engineers 1791 Tullie Circle, NE Atlanta, GA 30329-2305 www.ashrae.org	800/527-4723 404/636-8400
ASLA	American Society of Landscape Architects 4401 Connecticut Ave., NW, 5th Floor Washington, DC 20008-2369 www.asla.org	202/686-2752
ASME	American Society of Mechanical Engineers 345 East 47th Street New York, NY 10017-2392 www.asme.org	800/434-2763
ASPE	American Society of Plumbing Engineers 3617 Thousand Oaks Blvd., Suite 210 Westlake, CA 91362-3649	805/495-7120
ASQC	American Society for Quality Control 611 E. Wisconsin Avenue Milwaukee, WI 53201-3005 www.asqc.org	800/248-1946 414/272-8575
ASSE	American Society of Sanitary Engineering	216/835-3040

	28901 Clemens Road Westlake, OH 44145 www.asse-plumbing.org	
ASTM	American Society for Testing and Materials 100 Barr Harbor Drive West Conshohocken, PA 19428-2959 www.astm.org	610/832-9500
AWCI	Association of the Wall and Ceiling Industries--International 307 E. Annandale Road, Suite 200 Falls Church, VA 22042-2433 www.awci.org	703/534-8300
AWPA	American Wood-Preservers' Association 3246 Fall Creek Highway, Suite 1900 Granbury, TX 76049-7979	817/326-6300
AWS	American Welding Society 550 NW LeJeune Road Miami, FL 33126 www.amweld.org	800/443-9373 305/443-9353
AWWA	American Water Works Association 6666 West Quincy Avenue Denver, CO 80235 www.awwa.org	800/926-7337 303/794-7711
BHMA	Builders' Hardware Manufacturers Association 355 Lexington Avenue, 17th Floor New York, NY 10017-6603	212/661-4261
CBM	Certified Ballast Manufacturers Association 1422 Euclid Avenue, Suite 402 Cleveland, OH 44115-2094	216/241-0711
CGA	Compressed Gas Association 1725 Jefferson Davis Hwy, Suite 1004 Arlington, VA 22202-4102 www.cganet.com	703/412-0900
CISCA	Ceilings & Interior Systems Construction Association 1500 Lincoln Hwy, Suite 202 St. Charles, IL 60174 www.cisca.org	630/584-1919
CISPI	Cast Iron Soil Pipe Institute 5959 Shallowford Road, Suite 419 Chattanooga, TN 37421	423/892-0137
CPSC	Consumer Product Safety Commission	800/638-2772

	East West Towers 4330 East-West Hwy. Bethesda, MD 20814	
CPPA	Corrugated Polyethylene Pipe Association 432 N. Superior Street Toledo, OH 43604	800/510-2772 419/241-2221
CRA	California Redwood Association 405 Enfrente Drive, Suite 200 Novato, CA 94949	415/382-0662
CRI	Carpet and Rug Institute 310 S. Holiday Avenue Dalton, GA 30722-2048 www.carpet-rug.com	800/882-8846 706/278-3176
CRSI	Concrete Reinforcing Steel Institute 933 N. Plum Grove Road Schaumburg, IL 60173-4758 www.crsi.org	847/517-1200
CTI	Ceramic Tile Institute of America 12061 W. Jefferson Blvd. Culver City, CA 90230-6219	310/574-7800
DHI	Door and Hardware Institute 14170 Newbrook Drive Chantilly, VA 20151-2223 www.dhi.org	703/222-2010
DIPRA	Ductile Iron Pipe Research Association 245 Riverchase Pkwy East, Suite O Birmingham, AL 35244	205/988-9870
DOC	Department of Commerce 14th Street and Constitution Avenue, NW Washington, DC 20230	202/482-2000
DOT	Department of Transportation 400 Seventh Street, SW Washington, DC 20590	202/366-4000
EJMA	Expansion Joint Manufacturers Association 25 N. Broadway Tarrytown, NY 10591-3201	914/332-0040
EPA	Environmental Protection Agency 401 M Street, SW Washington, DC 20460	202/260-2090
FCICA	Floor Covering Installation Contractors Association	706/226-5488

	P.O. Box 948 Dalton, GA 30722-0948	
FM	Factory Mutual 1151 Boston-Providence Turnpike P.O. Box 9102 Norwood, MA 02062-9102 www.factorymutual.com	781/255-4300
FS	Federal Specifications Unit (Available from GSA) 470 East L'Enfant Plaza, SW, Suite 8100 Washington, DC 20407	202/619-8925
GA	Gypsum Association 810 First Street NE, Suite 510 Washington, DC 20002 www.usg.com	202/289-5440
GANA	Glass Association of North America 3310 SW Harrison Street Topeka, KS 66611-2279 www.glasswebsite.com/gana	913/266-7013
HMA	Hardwood Manufacturers Association 400 Penn Center Blvd., Suite 530 Pittsburgh, PA 15235-5605 www.hardwood.org	412/828-0770
HPVA	Hardwood Plywood and Veneer Association 1825 Michael Farraday Drive P.O. Box 2789 Reston, VA 22195-0789 www.hpva.org	703/435-2900
IEEE	Institute of Electrical and Electronic Engineers 345 E. 47th Street New York, NY 10017-2394 www.ieee.org	800/678-4333 212/705-7900
IESNA	Illuminating Engineering Society of North America 120 Wall Street, 17th Floor New York, NY 10005-4001 www.iesna.org	212/248-5000
ITS	Intertek Testing Services P.O. Box 2040 607/753-6711 3933 US Route 11 Cortland, NY 13045-7902 www.itsglobal.com	800/345-3851
LMA	Laminating Materials Association 116 Lawrence Street	201/664-2700

	Hillsdale, NJ 07642-2730 www.lma.org	
MCAA	Mechanical Contractors Association of America 1385 Piccard Drive Rockville, MD 20850-4329	301/869-5800
ML/SFA	Metal Lath/Steel Framing Association (A Division of the NAAMM) 8 South Michigan Avenue, Suite 1000 Chicago, IL 60603	312/456-5590
MSS	Manufacturers Standardization Society for the Valve and Fittings Industry 127 Park Street, NE Vienna, VA 22180-4602	703/281-6613
NAA	National Arborist Association P.O. Box 1094 603/673-3311 Amherst, NH 03031-1094 www.natlarb.com	800/733-2622
NAAMM	National Association of Architectural Metal Manufacturers 8 South Michigan Avenue, Suite 1000 Chicago, IL 60603 www.gss.net/naamm	312/782-5590
NAIMA	North American Insulation Manufacturers Association 44 Canal Center Plaza, Suite 310 Alexandria, VA 22314 www.naima.org	703/684-0084
NAPA	National Asphalt Pavement Association NAPA Building 5100 Forbes Blvd. Lanham, MD 20706-4413	301/731-4748
NCSPA	National Corrugated Steel Pipe Association 1255 23rd Street, NW, Suite 850 Washington, DC 20037 www.ncspa.org	202/452-1700
NEBB	National Environmental Balancing Bureau 8575 Grovemont Circle Gaithersburg, MD 20877-4121	301/977-3698
NECA	National Electrical Contractors Association 3 Bethesda Metro Center, Suite 1100 Bethesda, MD 20814-5372	301/657-3110
NEI	National Elevator Industry	201/944-3211

	185 Bridge Plaza North, Suite 310 Fort Lee, NJ 07024	
NEMA	National Electrical Manufacturers' Association 1300 N. 17th Street, Suite 1847 Rosslyn, VA 22209 www.nema.org	703/841-3200
NFPA	National Fire Protection Association One Batterymarch Park P.O. Box 9101 Quincy, MA 02269-9101 www.nfpa.org	800/344-3555 617/770-3000
NHLA	National Hardwood Lumber Association P.O. Box 34518 Memphis, TN 38184-0518 www.natllhardwood.org	901/377-1818
NIA	National Insulation Association 99 Canal Center Plaza, Suite 222 Alexandria, VA 22314 www.insulation.org	703/683-6422
NPA	National Particleboard Association 18928 Premiere Court Gaithersburg, MD 20879-1569 www.pbmdf.com	301/670-0604
NPCA	National Paint and Coatings Association 1500 Rhode Island Avenue, NW Washington, DC 20005-5597 www.paint.org	202/462-6272
NRCA	National Roofing Contractors Association O'Hare International Center 10255 W. Higgins Road, Suite 600 Rosemont, IL 60018-5607 www.roofonline.org	800/323-9545
NRMCA	National Ready Mixed Concrete Association 900 Spring Street Silver Spring, MD 20910 www.nrmca.org	301/587-1400
NSF	NSF International P.O. Box 130140 Ann Arbor, MI 48113-0140 www.nsf.org	313/769-8010
NUSIG	National Uniform Seismic Installation Guidelines 12 Lahoma Court Alamo, CA 94526	510/946-0135

NWWDA	National Wood Window and Door Association 1400 E. Touhy Avenue, G-54 Des Plaines, IL 60018 www.nwwda.org	800/223-2301 847/299-5200
SHA	Occupational Safety and Health Administration (U.S. Department of Labor) 200 Constitution Ave., NW Washington, DC 20210	202/219-8148
PCA	Portland Cement Association 5420 Old Orchard Road Skokie, IL 60077-1083 www.portcement.org	847/966-6200
PDCA	Painting and Decorating Contractors of America 3913 Old Lee Hwy, Suite 33-B Fairfax, VA 22030 www.pdca.com	800/332-7322 703/359-0826
PDI	Plumbing and Drainage Institute 45 Bristol Drive, Suite 101 South Easton, MA 02375	800/589-8956 508/230-3516
RFCI	Resilient Floor Covering Institute 966 Hungerford Drive, Suite 12-B Rockville, MD 20805-1714	301/340-8580
RIS	Redwood Inspection Service c/o California Redwood Association 405 Enfrente Drive, Suite 200 Novato, CA 94949-7206	415/382-0662
SDI	Steel Deck Institute P.O. Box 25 Fox River Grove, IL 60012 www.sdi.org	847/462-1930
SDI	Steel Door Institute 30200 Detroit Road Cleveland, OH 44145-1967	216/889-0010
SMA	Stucco Manufacturers Association 14006 Ventura Blvd. Sherman Oaks, CA 91403	213/789-8733
SMACNA	Sheet Metal and Airconditioning Contractors National Association, Inc. P.O. Box 221230 Chantilly, VA 20151-1209 www.smacna.org	703/803-2980

SPI	Society of the Plastics Industry, Inc. Spray Polyurethane Division 1801 K Street, NW, Suite 600K Washington, DC 20006 www.socplas.org	800/951-2001 202/974-5200
SSPC	Steel Structures Painting Council 40 24th Street, 6th Floor Pittsburgh, PA 15222-4643	412/281-2331
TCA	Tile Council of America 100 Clemson Research Blvd. Anderson, SC 29625	864/646-8453
TPI	Turfgrass Producers International 1855-A Hicks Road Rolling Meadows, IL 60008	800/405-8873 847/705-9898
UL	Underwriters Laboratories, Inc. 333 Pfingston Road Northbrook, IL 60062 www.ul.com	847/272-8800 800/704-4050
UNI	Uni-Bell PVC Pipe Association 2655 Villa Creek Drive, Suite 155 Dallas, TX 75234 www.members.aol.com/unibell1	972/243-3902
USDA	U.S. Department of Agriculture 14th St. and Independence Ave., SW Washington, DC 20250	202/720-8732
WA	Wallcoverings Association 401 N. Michigan Avenue Chicago, IL 60611-4267	312/644-6610
WCLIB	West Coast Lumber Inspection Bureau P.O. Box 23145 Portland, OR 97281-3145	503/639-0651
WCMA	Window Covering Manufacturers Association 355 Lexington Ave., 17th Floor New York, NY 10017-6603	212/661-4261
WIC	Woodwork Institute of California P.O. Box 980247 West Sacramento, CA 95798-0247	916/372-9943
WLPDIA	Western Lath/Plaster/Drywall Industries Association 8635 Navajo Road San Diego, CA 92119	619/466-9070

WMMPA	Wood Moulding & Millwork Producers Association 507 First Street Woodland, CA 95695 www.wmmpa.com	800/550-7889 916/661-9591
WRI	Wire Reinforcement Institute 203 Loudoun Street, SW Leesburg, VA 20175-2718	703/779-2339
WWPA	Western Wood Products Association Yeon Building 522 S.W. 5th Avenue Portland, OR 97204-2122	503/224-3930

END OF DOCUMENT

DOCUMENT 01 45 29

TESTING LABORATORY SERVICES

1. GENERAL

1.1. RELATED DOCUMENTS AND PROVISION

Contractor shall review all Contract Documents for applicable provisions related to the provisions in this document, including without limitation:

- 1.1.1. General Conditions, including “Tests and Inspections”; and
- 1.1.2. Special Conditions.

1.2. DOCUMENT INCLUDES

- 1.2.1. Observation and Supervision.
- 1.2.2. Testing Laboratories and Agencies
- 1.2.3. Tests and Inspections
- 1.2.4. Selection and Payment
- 1.2.5. District's Testing Laboratory Responsibilities
- 1.2.6. Laboratory reports.
- 1.2.7. Limits on testing laboratory authority.
- 1.2.8. Contractor responsibilities.
- 1.2.9. Schedule of inspections and tests.
- 1.2.10. Project Inspector’s Access to Site

1.3. REFERENCES

- 1.3.1. ASTM D3740 - Practice for Evaluation of Agencies Engaged in Testing and/or Inspection of Soil and Rock as Used in Engineering Design and Construction.
- 1.3.2. ASTM E329 - Recommended Practice for Inspection and Testing Agencies for Concrete, Steel, and Bituminous Materials as Used in Construction.
- 1.3.3. CBC - California Building Code.
- 1.3.4. UBC - Uniform Building Code.
- 1.3.5. Title 24, Parts 1 and 2, of the California Code of Regulations. Contractor shall keep a copy of these available at the job Site for ready reference during construction

- 1.3.6. DSA - Division of the State Architect, Office of Regulation Services, Structural Safety Section. DSA shall be notified at or before the start of construction.

1.4. OBSERVATION AND SUPERVISION

- 1.4.1. The District and Architect or their appointed representatives will review the Work and the Contractor shall provide facilities and access to the Work at all times as required to facilitate this review. Administration by the Architect and any consulting Structural Engineer will be in accordance with applicable regulations, including, without limitation, 24 C.C.R. §4-341.
- 1.4.2. One or more Project Inspector(s) approved by DSA and employed by or in contract with the District("Project Inspector"), will observe the Work in accordance with 24 C.C.R. §§4-333(b) and 4-342:
- 1.4.3. Project Inspector shall have access to the Work wherever it is in preparation or progress for ascertaining that the Work is in accordance with the Contract Documents and all applicable code sections. Contractor shall provide facilities and access as required and shall provide assistance for sampling or measuring materials.
 - 1.4.3.1. Project Inspector will notify District and Architect and inform Contractor of any observed failure of Work or material to conform to Contract Documents.
 - 1.4.3.2. The Project Inspector shall observe and monitor all testing and inspection activities required.
- 1.4.4. Contractor shall conform with all applicable laws as indicated in the Contract Documents, including, without limitation, to 24 C.C.R. §4-343. Contractor shall supervise and direct the Work and maintain a competent superintendent on the Project who is authorized to act in all matters pertaining to the Work. The Contractor shall inspect all materials, as they arrive, for compliance with the Contract Documents. Contractor shall reject defective Work or materials immediately upon delivery or failure of the Work or material to comply with the Contract Documents. The Contractor shall submit verified reports as indicated in the Contract Documents, including, without limitation, the Specifications and as required by 24 C.C.R. §4-336.

1.5. TESTING LABORATORIES AND AGENCIES

- 1.5.1. Testing agencies and tests shall be in conformance with the Contract Documents and the requirements of 24 C.C.R. §4-335.
- 1.5.2. Testing and inspection in connection with earthwork shall be under the direction of the District's consulting soils engineer ("Soils Engineer").
- 1.5.3. Testing and inspection of construction materials and workmanship shall be performed by a qualified laboratory ("Testing Laboratory" or "Laboratory"). The Testing Laboratory shall be under direction of an engineer registered in the State of California, shall conform to requirements of ASTM E329, and shall be employed by or in contract with the District.

1.6. TESTS AND INSPECTIONS

- 1.6.1. Contractor shall be responsible for notifying District and Project Inspector of all required tests and inspections. Contractor shall notify District and Project Inspector forty-eight (48) hours in advance of performing any Work requiring testing or inspection.
- 1.6.2. Contractor shall provide access to Work to be tested and furnish incidental labor, equipment, and facilities to facilitate all inspections and tests.
- 1.6.3. District will pay for first inspections and tests required by the Title 24 and other inspections or tests that District and/or Architect may direct to have made, including, but not limited to, the following principal items:
 - 1.6.3.1. Tests and observations for earthwork and paving.
 - 1.6.3.2. Tests for concrete mix designs, including tests of trial batches.
 - 1.6.3.3. Tests and inspections for structural steel work.
 - 1.6.3.4. Field tests for framing lumber moisture content.
 - 1.6.3.5. Additional tests directed by District that establish that materials and installation comply with the Contract Documents.
 - 1.6.3.6. Test and observation of welding and expansion anchors.
 - 1.6.3.7. Factory observation of components and assembly of modular prefabrication structures and buildings.
- 1.6.4. District may at its discretion, pay and back charge Contractor for:
 - 1.6.4.1. Retests or re-inspections, if required, and tests or inspection required due to Contractor error or lack of required identifications of material.
 - 1.6.4.2. Uncovering of work in accordance with Contract Documents.
 - 1.6.4.3. Testing done on weekends, holidays, and overtime will be chargeable to Contractor for the overtime portion.
 - 1.6.4.4. Testing done off site.
- 1.6.5. Testing and inspection reports and certifications:
 - 1.6.5.1. If initially received by Contractor, Contractor shall provide to each of the following a copy of the agency or laboratory report of each test or inspection or certification: District; Construction Manager, if any; Architect; Consulting Engineer, if any; Other Engineers on the Project, as appropriate; and; Project Inspector.
 - 1.6.5.2. When the test or inspection is one required by the Title 24, a copy of the report shall also be provided to the DSA.

1.7. SELECTION AND PAYMENT

- 1.7.1. District will hire and pay for services of an independent Testing Laboratory to perform specified inspection and testing as specified by District's Testing Laboratory.
- 1.7.2. District's hiring of Testing Laboratory shall in no way relieve Contractor of its obligation to perform work in accordance with requirements of Contract Documents.

1.8. DISTRICT'S TESTING LABORATORY RESPONSIBILITIES

- 1.8.1. Test samples of mixes submitted by Inspector.
- 1.8.2. Perform specified inspection, sampling, and testing of Products in accordance with specified standards.
- 1.8.3. Notify Architect and Contractor of observed irregularities or non-conformance of Work or Products.
- 1.8.4. Attend preconstruction conferences and progress meetings when requested by Architect.

1.9. LABORATORY REPORTS

- 1.9.1. After each inspection and test, District shall then submit one copy of laboratory report to Contractor. Reports of test results of materials and inspections found not to be in compliance with the requirements of the Contract Documents shall be forwarded immediately.
- 1.9.2. Each Testing Laboratory shall submit a verified report covering all of the tests which were required to be made by that agency during the progress of the Project. Such report shall be furnished each time that Work is suspended, covering the tests up to that time and at the Completion of the Project, covering all tests.

1.10. LIMITS ON TESTING LABORATORY AUTHORITY

- 1.10.1. Laboratory may not release, revoke, alter, or enlarge on requirements of Contract Documents.
- 1.10.2. Laboratory may not approve or accept any portion of the Work.
- 1.10.3. Laboratory may not assume any duties of Contractor.
- 1.10.4. Laboratory has no authority to stop the Work.

1.11. CONTRACTOR RESPONSIBILITIES

- 1.11.1. Submit proposed items for testing as required herein and/or as further required in the Contract Documents to Architect for review in accordance with applicable specifications.
- 1.11.2. Cooperate with Laboratory personnel, and provide access to the Work and to manufacturer's facilities.

- 1.11.3. Notify Architect, District's , and Testing Laboratory 48 hours prior to expected time for operations requiring inspection and testing services.
- 1.11.4. When tests or inspections cannot be performed after such notice, reimburse District for Laboratory personnel and travel expenses incurred due to the Contractor's negligence.
- 1.11.5. Contractor shall notify District a sufficient time in advance of the manufacture of material to be supplied by Contractor pursuant to the Contract Documents, which must by terms of the Contract be tested, in order that the District may arrange for the testing of same at the source of supply.
 - 1.11.5.1. Any material shipped by the Contractor from the source of supply prior to having satisfactorily passed such testing and inspection or prior to the receipt of notice that such testing and inspection will not be required shall not be incorporated in the Work.
- 1.11.6. Contract and pay for services of District's Testing Laboratory to perform additional inspections, sampling and testing required when initial tests indicate Contractor's work and/or materials does not comply with Contract Documents.

1.12. SCHEDULE OF INSPECTIONS AND TESTS

The Testing Laboratory shall perform tests and inspections for the following in conformance with the (CBC) California Building Code (International Building Code with State of California Amendments), California Code of Regulations, Title 24, Part 2:

- Structural Tests and Special Inspections (Chapter 17A)
 - Special Inspections (§ 1704A)
- Soils and Foundations (Chapter 18A)
 - Geotechnical Investigations (§ 1803A)
- Concrete (Chapter 19A)
 - Specifications for Tests and Materials (§)
 - Concrete Quality, Mixing and Placing (§)
 - Concrete Reinforcement and Anchor Testing Inspection (§ 1916A)
- Masonry (Chapter 21A)
 - Masonry Construction Materials (§ 2103A)
 - Masonry Quality (§ 2103A)
 - Quality Assurance (§ 2105A)
- Structural Steel (Chapter 22A)
 - Structural Steel (§ 2205A)
 - Identification & Protection of Steel for Structural Purposes (§ 2203A)
 - Inspection and Tests of Structural Steel (§ 2212A)
- Wood (Chapter 23)
 - Minimum Standards and Quality (§ 2303)
 - Wood Construction (§ 1704A.6)
- Exterior Walls (Chapter 14)
 - Masonry Units (§ 1404.4)
 - Masonry Construction Materials (§ 2103A)
 - Exterior Insulation and Finish Systems (§ 1408)
- Roof Assemblies and Roofing Structures (Chapter 15)
 - Materials (§ 1506)
- Aluminum (Chapter 20)

- Materials (§ 2002.1)
- Inspection (§ 2003.1)

1.12.1. Plumbing

Testing as specified in Division 15 including, but not limited to: Sterilization, soil waste and vent, water piping, source of water, gas piping, downspouts and storm drains.

1.12.2. Automatic Fire Sprinklers (where applicable)

Testing as specified in Division 15 shall include, but not be limited to: hydrostatic pressure.

1.12.3. Heating, Ventilating and Air Conditioning:

Testing as specified in Division 15 shall include, but not be limited to: Ductwork tests, cooling tower tests, boiler tests, controls testing, piping tests, water and air systems, and test and balance of heating and air conditioning systems.

1.12.4. Electrical

Testing as specified in Division 16, including, but not limited to: Equipment testing, all electrical system operations, grounding system and checking insulation after cable is pulled.

1.13. PROJECT INSPECTOR'S ACCESS TO SITE

- 1.13.1. A Project Inspector employed by the District in accordance with the requirement of State of California Code of Regulations, Title 24, Part 1 will be assigned to the Work. Project Inspector's duties are specifically defined in 24. C.C.R. §4-342, and as indicated in the General Conditions.
- 1.13.2. District and Construction Manager shall at all times have access for the purpose of inspection to all parts of the Work and to the shops wherein the Work is in preparation, and Contractor shall at all times maintain proper facilities and provide safe access for such inspection.
- 1.13.3. The Work in all stages of progress shall be subject to the personal continuous observation of the Inspector. Inspector shall have free access to any or all parts of the Work at any time. Contractor shall furnish the Inspector reasonable facilities for obtaining such information as may be necessary to keep Inspector fully informed respecting the progress and manner of the Work and the character of the materials. Inspection of the Work shall not relieve the Contractor from any obligation set forth in the Contract Documents.
- 1.13.4. The Inspector is not authorized to change, revoke, alter, enlarge or decrease in any way any requirement of the Contract Documents, drawings, specifications or subsequent change orders.
- 1.13.5. Whenever there is insufficient evidence of compliance with any of the provisions of Title 24 or evidence that any material or construction does not conform to the requirements of Title 24, the Division of the State Architect may require tests as proof of compliance. Test methods shall be as specified herein or by other recognized and accepted test methods determined by the Division of the State Architect. All tests shall be performed by a testing laboratory accepted by the Division of the State Architect.

END OF DOCUMENT

DOCUMENT 01 50 00

TEMPORARY FACILITIES AND CONTROLS

1. GENERAL

1.1. RELATED DOCUMENTS AND PROVISIONS

Contractor shall review all Contract Documents for applicable provisions related to the provisions in this document, including without limitation:

- 1.1.1. General Conditions;
- 1.1.2. Special Conditions;
- 1.1.3. Site Standards; and
- 1.1.4. Temporary Tree and Plant Protection.

1.2. TEMPORARY UTILITIES

1.2.1. Electric Power and Lighting

- 1.2.1.1. District MAY allow Contractor to connect and utilize District services for duration of the contract. Contractor shall be responsible for any cost associated with connection or associated fees. However, District at its sole discretion, reserves the right to terminate and discontinue at any time.
- 1.2.1.2. Where District services are not available or feasible:
 - 1.2.1.2.1. Contractor will furnish and pay for power during the course of the work to the -extent power is not in the building(s) or on the Site. Contractor shall be responsible for providing temporary facilities required on the Site to point of intended use.
 - 1.2.1.2.2. Contractor shall furnish, wire for, install, and maintain temporary electrical lights wherever it is necessary to provide illumination for the proper performance and/or observation of the Work: a minimum of 20 foot-candles for rough work and 50 foot-candles for finish work.
 - 1.2.1.2.3. Contractor shall be responsible for maintaining existing lighting levels in the Project vicinity should temporary outages or service interruptions occur.

1.2.2. Heat and Ventilation

- 1.2.2.1. Contractor shall provide temporary heat to maintain environmental conditions to facilitate progress of the Work, to meet specified minimum conditions for the installation and curing of materials, and to protect materials and finishes from damage due to improper temperature and humidity conditions. Portable heaters shall be standard units complete with controls.
- 1.2.2.2. Contractor shall provide forced ventilation and dehumidification, as required, of enclosed areas for proper installation and curing of materials, to disperse humidity, and to prevent hazardous accumulations of dust, fumes, vapors, and gases.
- 1.2.2.3. Contractor shall pay the costs of installation, maintenance, operation, and

removal of temporary heat and ventilation, including costs for fuel consumed, required for the performance of the Work.

1.2.3. Water

1.2.3.1. District MAY allow Contractor to connect and utilize District services for duration of the contract. Contractor shall be responsible for any cost associated with connection or associated fees. However, District at its sole discretion, reserves the right to terminate and discontinue at any time.

1.2.3.2. Where District services are not available or feasible:

1.2.3.2.1. Contractor will furnish and pay for water during the course of the work. Contractor shall be responsible for providing temporary facilities required.

1.2.3.2.2. Contractor shall make potable water available for human consumption.

1.2.4. Sanitary Facilities

1.2.4.1. Contractor shall provide sanitary temporary facilities in no fewer numbers than required by law and such additional facilities as may be directed by the Inspector for the use of all workers. The facilities shall be maintained in a sanitary condition at all times and shall be left at the Site until removal is directed by the Project Inspector or Contractor completes all Work.

1.2.4.2. Use of toilet facilities in the Work shall not be permitted except by consent of the Project Inspector and District.

1.2.5. Telephone Service

1.2.5.1. Contractor shall arrange with local telephone service company for telephone service for the performance of the Work. Contractor shall, at a minimum, provide in its field office one line for telephone and one line for fax machine.

1.2.5.2. Contractor shall pay the costs for telephone and fax lines installation, maintenance, service, and removal; for Construction Site Office, Construction Manager's Office and Inspector's Office.

1.2.6. Fire Protection:

1.2.6.1. Contractor shall provide and maintain fire extinguishers and other equipment for fire protection. Such equipment shall be designated for use for fire protection only and shall comply with all requirements of the California Fire, State Fire Marshall and/or its designee.

1.2.6.2. Where on-site welding and burning of steel is unavoidable, Contractor shall provide protection for adjacent surfaces.

1.2.7. Trash Removal:

Contractor shall provide trash removal on a timely basis from all Site Offices and throughout the Site.

1.2.8. Temporary Facilities:

1.2.8.1. Unless otherwise indicated in the Special Conditions, Contractor shall provide the following facilities, trailers, offices, furniture and services:

- 1.2.8.1.1. one (1) 12X60 office trailer with two (2) offices for two (2) Construction Managers;
- 1.2.8.1.2. one (1) 12X20 Project Inspector's Trailer/Office; and
- 1.2.8.1.3. Basic furniture: chair, desks plan table, conference room table and chairs.

1.3. CONSTRUCTION AIDS

1.3.1. Plant and Equipment:

- 1.3.1.1. Contractor shall furnish, operate, and maintain a complete plant for fabricating, handling, conveying, installing, and erecting materials and equipment; and for conveyances for transporting workmen. Include elevators, hoists, debris chutes, and other equipment, tools, and appliances necessary for performance of the Work.
- 1.3.1.2. Contractor shall maintain plant and equipment in safe and efficient operating condition. Damages due to defective plant and equipment, and uses made thereof, shall be repaired by Contractor at no expense to the District.

- 1.3.2. No District tools or equipment shall be used by Contractor for the performance of the Work.

1.4. BARRIERS AND ENCLOSURES

- 1.4.1. Contractor shall obtain District's written permission for locations and types of temporary barriers and enclosures, including fire-rated materials proposed for use, prior to their installation.
- 1.4.2. Contractor shall provide a six (6) foot high, chain link perimeter fence with post driven into the ground and fabric screen as a temporary barrier around construction area. Contractor shall provide and maintain temporary enclosures to prevent public entry and to protect persons using other buildings and portions of the Site and/or Premises. Contractor shall remove temporary fence, barriers and enclosure upon Completion of the Work.
- 1.4.3. Contractor shall provide site access to existing facilities for persons using other buildings and portions of the Site, the public, and for deliveries and other services and activities.

1.5. SECURITY

Contractor shall secure all construction equipment, machinery and vehicles, park and store only within fenced area, and render inoperable during non-work hours. Contractor is responsible for insuring that no construction materials, tools, equipment, machinery or vehicles can be used for unauthorized entry or other damage or interference to activities and security of existing facilities adjacent to and in the vicinity of the Project Site.

1.6. TEMPORARY CONTROLS

1.6.1. Noise Control

- 1.6.1.1. Contractor acknowledges that adjacent facilities may remain in operation during all or a portion of the Work, and it shall take all reasonable precautions to minimize noise as required by applicable laws and the Contract Documents.
- 1.6.1.2. Notice of proposed noisy operations, including without limitation, operation of

pneumatic demolition tools, concrete saws, and other equipment, shall be submitted to District a minimum of forty-eight (48) hours in advance of their performance.

1.6.2. Noise and Vibration

- 1.6.2.1. Equipment and impact tools shall have intake and exhaust mufflers.
- 1.6.2.2. Contractor shall cooperate with District to minimize and/or cease the use of noisy and vibratory equipment if that equipment becomes objectionable by its longevity.

1.6.3. Dust and Dirt

- 1.6.3.1. Contractor shall conduct demolition and construction operations to minimize the generation of dust and dirt, and prevent dust and dirt from interfering with the progress of the Work and from accumulating in the Work and adjacent areas including, without limitation, occupied facilities.
- 1.6.3.2. Contractor shall periodically water exterior demolition and construction areas to minimize the generation of dust and dirt.
- 1.6.3.3. Contractor shall ensure that all hauling equipment and trucks carrying loads of soil and debris shall have their loads sprayed with water or covered with tarpaulins, and as otherwise required by local and state ordinance.
- 1.6.3.4. Contractor shall prevent dust and dirt from accumulating on walks, roadways, parking areas, and planting, and from washing into sewer and storm drain lines.

1.6.4. Water

Contractor shall not permit surface and subsurface water, and other liquids, to accumulate in or about the vicinity of the Premises. Should accumulation develop, Contractor shall control the water or other liquid, and suitably dispose of it by means of temporary pumps, piping, drainage lines, troughs, ditches, dams, or other methods.

1.6.5. Pollution

- 1.6.5.1. No burning of refuse, debris, or other materials shall be permitted on or in the vicinity of the Premises.
- 1.6.5.2. Contractor shall comply with applicable regulatory requirements and anti-pollution ordinances during the conduct of the Work including, without limitation, demolition, construction, and disposal operations.

1.6.6. Lighting

If portable lights are used after dark, all light must be located so as not to direct light into neighboring property.

1.7. JOB SIGN(S)

1.7.1. General:

- 1.7.1.1. Contractor shall provide and maintain and locate a Project identification sign with the design, text, and colors designated by District and/or the Architect.
- 1.7.1.2. Signs other than the specified Project sign and or signs required by law, for safety, or for egress, shall not be permitted, unless otherwise approved in

advance by the District.

1.7.2. Materials:

- 1.7.2.1. Structure and Framing: Structurally sound, new or used wood or metal; wood shall be nominal 3/4-inch exterior grade plywood.
- 1.7.2.2. Sign Surface: Minimum 3/4-inch exterior grade plywood.
- 1.7.2.3. Rough Hardware: Galvanized.
- 1.7.2.4. Paint: Exterior quality, of type and colors selected by the District and/or the Architect.

1.7.3. Fabrication:

- 1.7.3.1. Contractor shall fabricate to provide smooth, even surface for painting.
- 1.7.3.2. Size: 4'-0" x 8'-0", unless otherwise indicated.
- 1.7.3.3. Contractor shall paint exposed surfaces of supports, framing, and surface material with exterior grade paint: one coat of primer and one coat of finish paint.
- 1.7.3.4. Text and Graphics: As indicated.

1.8. PUBLICITY RELEASES

Contractor shall not release any information, story, photograph, plan, or drawing relating information about the Project to anyone, including press and other public communications medium, including, without limitation, on website(s).

END OF DOCUMENT

DOCUMENT 01 52 10

SITE STANDARDS

1. GENERAL

1.1. RELATED DOCUMENTS AND PROVISIONS:

Contractor shall review all Contract Documents for applicable provisions related to the provisions in this document, including without limitation:

- 1.1.1. General Conditions, including without limitation, Site Access, Conditions, and Regulations;
- 1.1.2. Special Conditions;
- 1.1.3. Drug-Free Workplace Certification;
- 1.1.4. Tobacco-Free Environment Certification;
- 1.1.5. Criminal Background Investigation/Fingerprinting Certification; and
- 1.1.6. Temporary Facilities and Controls.

1.2. REQUIREMENTS OF THE DISTRICT

1.2.1. Drug-Free Schools and Safety Requirements:

- 1.2.1.1. All school sites and other District Facilities have been declared "Drug-Free Zones." No drugs, alcohol, smoking or the use of tobacco products are allowed at any time in any buildings, Contractor-owned vehicles or vehicles owned by others while on District property. No students, staff, visitors, or contractors are to use drugs on these sites.
- 1.2.1.2. Contractor shall post: "Non-Smoking Area" in a highly visible location on Site. Contractor may designate a smoking area outside of District property within the public right-of-way, provided that this area remains quiet and unobtrusive to adjacent neighbors. This smoking area must be kept clean at all times.
- 1.2.1.3. Contractor shall ensure that no alcohol, firearms, weapons, or controlled substances enter or are used at the Site. Contractor shall immediately remove from the Site and terminate the employment of any employee(s) found in violation of this provision.

- 1.2.2. **Language:** Unacceptable and/or loud language will not be tolerated, "Cat calls" or other derogatory language toward students or public will not be allowed.

1.2.3. Disturbing the Peace (Noise and Lighting):

- 1.2.3.1. Contractor shall observe the noise ordinance of the Site at all times including, without limitation, all applicable local, city, and/or state laws, ordinances, and/or regulations regarding noise and allowable noise levels.

1.2.3.2. The use of radios, etc., shall be controlled to keep all sound at a level that cannot be heard beyond the immediate area of use. District reserves the right to prohibit the use of radios at the Site, except for handheld communication radios.

1.2.3.3. If portable lights are used after dark, the lights must be located so as not to direct light into neighboring properties.

1.2.4. **Traffic:**

1.2.4.1. Driving on the Premises shall be limited to periods when students and public are not present. If driving or deliveries must be made during the school hours, two (2) or more ground guides shall lead the vehicle across the area of travel. In no case shall driving take place across playgrounds or other pedestrian paths during recess, lunch, and/or class period changes. The speed limit on-the Premises shall be five (5) miles per hour (maximum) or less if conditions require.

1.2.4.2. All paths of travel for deliveries, including without limitation, material, equipment, and supply deliveries, shall be reviewed and approved by District in advance. Any damage will be repaired to the pre-damaged condition by the Contractor.

1.2.4.3. District shall designate a construction entry to the Site. If Contractor requests, District determines it is required, and to the extent possible, District shall designate a staging area so as not to interfere with the normal functioning of school facilities. Location of gates and fencing shall be approved in advance with District and at Contractor's expense.

1.2.4.4. Parking areas shall be reviewed and approved by District in advance. No parking is to occur under the drip line of trees or in areas that could otherwise be damaged.

1.2.4.5. All of the above shall be observed and complied with by the Contractor and all workers on the Site. Failure to follow these directives could result in individual(s) being suspended or removed from the work force at the discretion of the District. The same rules and regulations shall apply equally to delivery personnel, inspectors, consultants, and other visitors to the Site.

END OF DOCUMENT

DOCUMENT 01 56 39

TEMPORARY TREE AND PLANT PROTECTION

WHERE SUBSTANTIAL TREE PROTECTION WILL BE REQUIRED ON THE SITE, OBTAIN AN ARBORIST TO REVIEW THIS DOCUMENT PRIOR TO BIDDING.

1. GENERAL

1.1. RELATED DOCUMENTS

Contractor shall review all Contract Documents for applicable provisions related to the provisions in this document, including without limitation:

- 1.1.1. General Conditions; and
- 1.1.2. Special Conditions.

1.2. SUMMARY

This Document includes the protection and trimming of existing trees that interfere with, or are affected by, execution of the Work, whether temporary or permanent construction.

1.3. DEFINITIONS

Tree Protection Zone: Area surrounding individual trees or groups of trees to remain during construction, and defined by the drip line of individual trees or the perimeter drip line of groups of trees, unless otherwise indicated.

1.4. SUBMITTALS

- 1.4.1. Product Data: For each type of product indicated.
- 1.4.2. Tree Pruning Schedule: Written schedule from arborist detailing scope and extent of pruning of trees to remain that interfere with or are affected by construction.
- 1.4.3. Qualification Data: For tree service firm and arborist.
- 1.4.4. Certification: From arborist, certifying that trees indicated to remain have been protected during construction according to recognized standards and that trees were promptly and properly treated and repaired when damaged.
- 1.4.5. Maintenance Recommendations: From arborist, for care and protection of trees affected by construction during and after completing the Work.

1.5. QUALITY ASSURANCE

- 1.5.1. Tree Service Firm Qualifications: An experienced tree service firm that has successfully completed tree protection and trimming work similar to that required for this Project and that will assign an experienced, qualified arborist to Project site during execution of tree protection and trimming.

- 1.5.2. Arborist Qualifications: An arborist certified by ISA (International Society of Arboriculture) or licensed in the jurisdiction where Project is located.
- 1.5.3. Tree Pruning Standard: Comply with ANSI A300 (Part 1), "Tree, Shrub, and Other Woody Plant Maintenance--Standard Practices (Pruning)."
 - 1.5.3.1. Before tree protection and trimming operations begin, meet with District to review tree protection and trimming procedures and responsibilities.

2. PRODUCTS

2.1. MATERIALS

- 2.1.1. Drainage Fill: Selected crushed stone, or crushed or uncrushed gravel, washed, ASTM D 448, Size 24, with 90 to 100 percent passing a 2-1/2-inch (63-mm) sieve and not more than 10 percent passing a 3/4-inch (19-mm) sieve.
- 2.1.2. Topsoil: Natural or cultivated surface-soil layer containing organic matter and sand, silt, and clay particles; friable, pervious, and black or a darker shade of brown, gray, or red than underlying subsoil; reasonably free of subsoil, clay lumps, gravel, and other objects more than 1 inch (25 mm) in diameter; and free of weeds, roots, and toxic and other nonsoil materials.
 - 2.1.2.1. Obtain topsoil only from well-drained sites where topsoil is 4 inches (100 mm) deep or more; do not obtain from bogs or marshes.
- 2.1.3. Filter Fabric: Manufacturer's standard, nonwoven, pervious, geotextile fabric of polypropylene, nylon, or polyester fibers.
- 2.1.4. Chain-Link Fence: Metallic-coated steel chain-link fence fabric of 0.120-inch- (3-mm-) diameter wire; a minimum of 48 inches (1200 mm) high; with 1.9-inch- (48-mm-) diameter line posts; 2-3/8-inch- (60-mm-) diameter terminal and corner posts; 1-5/8-inch- (41-mm-) diameter top rail; and 0.177-inch- (4.5-mm-) diameter bottom tension wire; with tie wires, hog ring ties, and other accessories for a complete fence system.
- 2.1.5. Select mulch as recommended by arborist or landscape architect.
- 2.1.6. Organic Mulch: Use shredded hardwood, ground or shredded bark, or wood and bark chips, all free of deleterious materials.

3. EXECUTION

3.1. PREPARATION

- 3.1.1. Temporary Fencing: Install temporary fencing around tree protection zones to protect remaining trees and vegetation from construction damage. Maintain temporary fence and remove when construction is complete.
- 3.1.2. Install chain-link fence according to ASTM F 567 and manufacturer's written instructions.

- 3.1.3. Protect tree root systems from damage caused by runoff or spillage of noxious materials while mixing, placing, or storing construction materials. Protect root systems from ponding, eroding, or excessive wetting caused by dewatering operations.
- 3.1.4. Mulch areas inside tree protection zones and other areas indicated.
 - 3.1.4.1. Select mulch as recommended by arborist or landscape architect.
 - 3.1.4.2. Apply 2-inch (50-mm) to 3-inch (75-mm) average thickness of organic mulch. Do not place mulch within 6 inches (150 mm) of tree trunks.
- 3.1.5. Do not store construction materials, debris, or excavated material inside tree protection zones. Do not permit vehicles or foot traffic within tree protection zones; prevent soil compaction over root systems.
- 3.1.6. Maintain tree protection zones free of weeds and trash.
- 3.1.7. Do not allow fires within tree protection zones.

3.2. EXCAVATION

- 3.2.1. Install shoring or other protective support systems to minimize sloping or benching of excavations where construction or utility excavation is near trees to be protected.
- 3.2.2. Do not excavate within tree protection zones, unless otherwise indicated.
- 3.2.3. Where excavation for new construction is required within tree protection zones, hand clear and excavate to minimize damage to root systems. Use narrow-tine spading forks and comb soil to expose roots.
 - 3.2.3.1. Do not allow exposed roots to dry out before placing permanent backfill. Provide temporary earth cover or pack with peat moss and wrap with burlap. Water and maintain in a moist condition. Temporarily support and protect roots from damage until they are permanently relocated and covered with soil.
- 3.2.4. Where utility trenches are required within tree protection zones, tunnel under or around roots by drilling, auger boring, pipe jacking, or digging by hand.
 - 3.2.4.1. Root Pruning: Do not cut main lateral roots or taproots; cut only smaller roots that interfere with installation of utilities. Cut roots with sharp pruning instruments; do not break or chop.

3.3. REGRADING

- 3.3.1. Grade Lowering: Where new finish grade is indicated below existing grade around trees, slope grade beyond tree protection zones. Maintain existing grades within tree protection zones.
- 3.3.2. Grade Lowering: Where new finish grade is indicated below existing grade around trees, slope grade away from trees as recommended by arborist, unless otherwise indicated.

3.3.2.1. Root Pruning: Prune tree roots exposed during grade lowering. Do not cut main lateral roots or taproots; cut only smaller roots. Cut roots with sharp pruning instruments; do not break or chop.

3.3.3. Minor Fill: Where existing grade is 6 inches (150 mm) or less below elevation of finish grade, fill with topsoil. Place topsoil in a single uncompacted layer and hand grade to required finish elevations.

3.3.4. Moderate Fill: Where existing grade is more than 6 inches (150 mm) but less than 12 inches (300 mm) below elevation of finish grade, place drainage fill, filter fabric, and topsoil on existing grade as follows:

3.3.4.1. Carefully place drainage fill against tree trunk approximately 2 inches (50 mm) above elevation of finish grade and extend not less than 18 inches (450 mm) from tree trunk on all sides. For balance of area within drip-line perimeter, place drainage fill up to 6 inches (150 mm) below elevation of grade.

3.3.4.2. Place filter fabric with edges overlapping 6 inches (150 mm) minimum.

3.3.4.3. Place fill layer of topsoil to finish grade. Do not compact drainage fill or topsoil. Hand grade to required finish elevations.

3.4. TREE PRUNING

3.4.1. Prune trees to remain that are affected by temporary and permanent construction.

3.4.2. Prune trees to remain to compensate for root loss caused by damaging or cutting root system. Provide subsequent maintenance during Contract period as recommended by arborist.

3.4.3. Pruning Standards: Prune trees according to ANSI A300 (Part 1), as recommended by arborist report.

3.4.4. Adjust pruning requirements per arborist's recommendations.

3.4.5. Cut branches with sharp pruning instruments; do not break or chop.

3.4.6. Modify below to specific project requirements.

3.4.7. Chip removed tree branches and dispose of or spread over areas identified by District.

3.5. TREE REPAIR AND REPLACEMENT

3.5.1. Promptly repair trees damaged by construction operations within 24 hours. Treat damaged trunks, limbs, and roots according to arborist's written instructions.

3.5.2. Remove and replace trees indicated to remain that die or are damaged during construction operations or that are incapable of restoring to normal growth pattern.

3.5.2.1. Provide new trees of 6-inch (150-mm) caliper size and of a when damaged trees more than 6 inches (150 mm) in caliper size, measured 12 inches (300 mm) above grade, are required to be replaced. Plant and maintain new trees as specified in Contract Documents.

- 3.5.3. Where recommended by arborist report, aerate surface soil, compacted during construction, 10 feet (3 m) beyond drip line and no closer than 36 inches (900 mm) to tree trunk. Drill 2-inch (50-mm) diameter holes a minimum of 12 inches (300 mm) deep at 24 inches (600 mm) o.c. Backfill holes with an equal mix of augered soil and sand.

3.6. DISPOSAL OF WASTE MATERIALS

- 3.6.1. Burning is not permitted.
- 3.6.2. Disposal: Remove excess excavated material and displaced trees from Site.

END OF DOCUMENT

DOCUMENT 01 57 10

STORM WATER POLLUTION PREVENTION PLAN – CONSTRUCTION

IN ORDER TO ENROLL IN THE CONSTRUCTION STORM WATER PERMIT AND BEFORE CONSTRUCTION ACTIVITIES BEGIN, THE DISTRICT WILL FILE CERTAIN SUBMITTALS REFERRED TO AS PERMIT REGISTRATION DOCUMENTS (PRDS) WITH THE REGIONAL WATER QUALITY CONTROL BOARD.

THE STATUS OF THE DISTRICT’S PRDS (THE RISK ASSESSMENT, SITE MAP(S), AND STORM WATER POLLUTION PREVENTION PLAN (SWPPP)) ARE AS FURTHER INDICATED IN THE SPECIAL CONDITIONS.

IF THE SPECIAL CONDITIONS INDICATE THAT CONTRACTOR SHALL BE RESPONSIBLE FOR PREPARING SOME OR ALL OF THE PRDS, CONTRACTOR SHALL FOLLOW THE REQUIREMENTS HEREIN.

1. GENERAL

1.1. RELATED DOCUMENTS AND PROVISION

Contractor shall review all Contract Documents for applicable provisions related to the provisions in this document, including without limitation:

- 1.1.1. General Conditions;
- 1.1.2. Special Conditions;
- 1.1.3. Site Standards; and
- 1.1.4. Collaborative For High Performance Schools (CHPS) -- Special Environmental Requirements.

1.2. The Clean Water Act and Porter Cologne Water Quality Act prohibit the discharge of any water containing pollutants from certain construction sites unless a National Pollutant Discharge Elimination System permit is first obtained and followed. The National Pollutant Discharge Elimination System General Permit for Storm Water Discharges Associated with Construction and Land Disturbance Activities (Construction Storm Water Permit) Order No. 2009-0009-DWQ as amended by Order No. 2010-0014-DWQ (NPDES No. CAS000002) issued by the California State Water Resources Control Board (State Water Board) authorizes the discharge of storm water and certain non-storm water from construction sites if certain conditions and measures are taken. The District has determined that the construction of this Project requires enrollment in the Construction Storm Water Permit.

2. SUBMITTALS

2.1. GENERAL

All submittals shall be made in a form conducive for the District to electronically upload the approved submittals to the Storm water Multi-Application Reporting and Tracking System (SMARTS).

2.2. RISK ASSESSMENT

- 2.2.1. Concurrent with the Schedule of Submittals as indicated in the General Conditions, Contractor shall prepare and submit a proposed “Risk Assessment” as set forth in the

Construction Storm Water Permit.

- 2.2.2. The District's Qualified SWPPP Developer ("QSD") will review the Contractor's proposed Risk Assessment for compliance with the Construction Storm Water Permit. If changes to the proposed Risk Assessment are required to comply with the Construction Storm Water Permit, the District QSD will identify such changes to the Contractor.
- 2.2.3. Contractor shall make the changes specified by the District's QSD and shall submit the revised Risk Assessment to the District within seven (7) days of receipt of the changes identified by the District's QSD. If the changes had been acceptably made, the District's QSD will approve the Risk Assessment and provide the Contract with a copy within seven (7) days of receipt of the revised Risk Assessment.

2.3. SITE MAPS

- 2.3.1. Concurrent with the Schedule of Submittals as indicated in the General Conditions, Contractor shall prepare and submit proposed "Site Maps" as described in Attachment B of the Construction Storm Water Permit.
- 2.3.2. The District's QSD will review the Contractor's proposed Site Maps for compliance with the Construction Storm Water Permit. If changes to the proposed Site Maps are required to comply with the Construction Storm Water Permit, the District QSD will identify such changes to the Contractor.
- 2.3.3. Contractor shall make the changes specified by the District's QSD and shall submit the revised Site Maps to the District within seven (7) days of receipt of the changes identified by the District's QSD. If the changes had been acceptably made, the District's QSD will approve the Site Maps and provide the Contract with a copy within seven (7) days of receipt of the revised SWPPP.

2.4. SWPPP

- 2.4.1. Concurrent with the Schedule of Submittals as indicated in the General Conditions, Contractor shall prepare and submit to the District a proposed SWPPP for the Work.
- 2.4.2. The District's Qualified SWPPP Developer ("QSD") will review the Contractor's proposed SWPPP for compliance with the Construction Storm Water Permit. If changes to the proposed SWPPP are required to comply with the Construction Storm Water Permit, the District QSD will identify such changes to the Contractor.
- 2.4.3. Contractor shall make the changes specified by the District's QSD and shall submit the revised SWPPP to the District within seven (7) days of receipt of the changes identified by the District's QSD. If the changes had been acceptably made, the District's QSD will approve the SWPPP and provide the Contract with a copy within seven (7) days of receipt of the revised SWPPP.

2.5. RAIN EVENT ACTION PLAN (REAP)

- 2.5.1. If Contractor determines that Site is a Risk Level 1, concurrent with the Schedule of Submittals as indicated in the General Conditions, Contractor shall prepare and submit to the District a proposed REAP for the Work.

- 2.5.2. The District's QSD will review the Contractor's proposed REAP for compliance with the Construction Storm Water Permit. If changes to the proposed REAP are required to comply with the Construction Storm Water Permit, the District QSD will identify such changes to the Contractor.
- 2.5.3. Contractor shall make the changes specified by the District's QSD and shall submit the revised REAP to the District within seven (7) days of receipt of the changes identified by the District's QSD. If the changes had been acceptably made, the District's QSD will approve the REAP and provide the Contract with a copy within seven (7) days of receipt of the revised REAP.

2.6. ACTIVE TREATMENT SYSTEM (ATS)

- 2.6.1. If Contractor determines that Site requires an ATS under the Construction Storm Water Permit, concurrent with the Schedule of Submittals as indicated in the General Conditions, Contractor shall prepare and submit to the District a proposed ATS for the Work.
- 2.6.2. The District's QSD will review the Contractor's proposed ATS for compliance with the Construction Storm Water Permit. If changes to the proposed ATS are required to comply with the Construction Storm Water Permit, the District QSD will identify such changes to the Contractor.
- 2.6.3. Contractor shall make the changes specified by the District's QSD and shall submit the revised ATS to the District within seven (7) days of receipt of the changes identified by the District's QSD. If the changes had been acceptably made, the District's QSD will approve the ATS and provide the Contract with a copy within seven (7) days of receipt of the revised ATS.

2.7. RECORDS

All electronic and hardcopy records required by the Construction Storm Water Permit shall be submitted to the District within seven (7) days of Completion of the Project.

3. PERMIT REGISTRATION DOCUMENTS

Prior to any activities on Site that disturb the Site's surface, the Permit Registration Documents (PRDs) required by the Construction Storm Water Permit must be filed with the Regional Water Quality Control Board. The District shall file the PRDs with the Regional Water Quality Control Board to activate coverage under the Construction Storm Water Permit.

4. IMPLEMENTATION REQUIREMENTS

- 4.1. Contractor shall not conduct any activities that may affect the Site's construction runoff water quality until the District provides Contractor with the Waste Discharger Identification Number (WDID) assigned to this Project by the State Water Board.
- 4.2. Contractor shall keep a copy of the approved SWPPP at the job site. The SWPPP shall be made available when requested by a representative of the Regional Water Quality Control Board, State Water Resources Control Board, United States Environmental Protection Agency, or the local storm water management agency. Requests from the public shall be directed to the District for response.

- 4.3. Contractor shall designate in writing to the District a Qualified SWPPP Practitioner (QSP) who shall be responsible for implementing the SWPPP, REAP (if applicable), ATS (if applicable), conducting non-storm water and storm water visual observations, and for ensuring that all best management practices (BMPs) required by the SWPPP and General Permit are properly implemented and maintained.
- 4.4. All measures required by the SWPPP shall be implemented concurrent with the commencement of construction. Pollution practices and devices shall be followed or installed as early in the construction schedule as possible with frequent upgrading of devices as construction progresses.
- 4.5. Contractor shall ensure that all measures are properly maintained and repaired to protect the water quality of discharges.

5. INSPECTION, SAMPLING, ANALYSIS, AND RECORD KEEPING REQUIREMENTS

The Contractor's QSP shall conduct all required visual observations, sampling, analysis, reporting, and record keeping required by the SWPPP and the Construction Storm Water Permit.

6. REPORTING REQUIREMENTS

Contractor shall prepare and provide all the reports, which include, but are not limited to the Annual Report and any NEL Violation Reports or NAL Exceedance Reports, all of which are required by the SWPPP and the Construction Storm Water Permit.

7. ANNUAL REPORT

By August 1 of each year (defined as July 1 to June 30) that had at least one continuous three (3) month period coverage under the General Permit, Contractor shall complete and submit to the District an Annual Report, as required by the General Permit. If the Project is complete prior to August 1, Contractor shall submit the report prior to acceptance of the Project.

8. COMPLETION OF WORK

- 8.1. Clean-up shall be performed as each portion of the work progresses. All refuse, excess material, and possible pollutants shall be disposed of in a legal manner off-site and all temporary and permanent SWPPP devices shall be in place and maintained in good condition.
- 8.2. At Completion of Work, Contractor shall inspect installed SWPPP devices, and present the currently implemented SWPPP with all backup records to the District.

9. NOTICE OF TERMINATION (NOT)

A Notice of Termination (NOT) must be submitted by the Contractor to the District for electronic submittal by the Legally Responsible Person via SMARTS to terminate coverage under the General Permit. The NOT must include a final Site Map and representative photographs of the Project site that demonstrate final stabilization has been achieved. The NOT shall be submitted to the District on or before the Contractor submits its final application for payment. If the Regional Water Board rejects the NOT for any reason, the Contractor shall revise the NOT as many times as necessary to get the Regional Water Board's approval. The Regional Water Board will consider a construction site complete when the conditions of the General Permit, Section II.D have been met.

10. QUALITY ASSURANCE

- 10.1. Before performing any of the obligations indicated herein, the Contractor's QSP shall meet the training and certification requirements in the Construction Storm Water Permit.
- 10.2. Contractor shall perform the Work in strict compliance with the approved SWPPP, REAP, ATS, and the Construction Storm Water Permit.
- 10.3. Contractor shall conduct at least a one-hour training session on the requirements of the SWPPP for each employee before an employee conducts any construction on the Site. Contractor shall maintain documentation of this employee training at the site for review by the District or any regulatory agency.

11. **PERFORMANCE REQUIREMENTS**

- 11.1. The Storm Water Pollution Prevention Plan is a minimum requirement. Revisions and modifications to the SWPPP are acceptable only if they maintain levels of protection equal to or greater than originally specified.
- 11.2. Read and be thoroughly familiar with all of the requirements of the SWPPP.
- 11.3. Inspect and monitor all work and storage areas for compliance with the SWPPP prior to any anticipated rain.
- 11.4. Complete any and all corrective measures as may be directed by the regulatory agency.
- 11.5. **Penalties:** Contractor shall pay any fees and any penalties that may be imposed by the regulatory agency for non-compliance with SWPPP during the course of Work.
- 11.6. **Costs:** Contractor to pay all costs associated with the implementation of the requirements of the SWPPP in order to maintain compliance with the Permit. This includes installation of all Housekeeping BMPs, General Site and Material Management BMPs, Inspection requirements, maintenance requirements, and all other requirements specified in the SWPPP.

12. **MATERIALS**

All temporary and permanent storm water pollution prevention facilities, equipment, and materials as required by or as necessary to comply with the SWPPP as described in the BMP Handbook.

END OF DOCUMENT

DOCUMENT 01 60 00

MATERIALS AND EQUIPMENT

1. GENERAL

1.1. RELATED DOCUMENTS AND PROVISIONS

Contractor shall review all Contract Documents for applicable provisions related to the provisions in this document, including without limitation:

- 1.1.1. General Conditions, including, without limitation, Purchase of Materials and Equipment;
- 1.1.2. Special Conditions; and
- 1.1.3. Imported Materials Certification.

1.2. MATERIAL AND EQUIPMENT

- 1.2.1. Only items approved by the District and/or Architect shall be used.
- 1.2.2. Contractor shall submit lists of Products and other Product information in accordance with the Contract Documents, including, without limitation, the provisions regarding the submittals.

1.3. MATERIAL AND EQUIPMENT COLORS

- 1.3.1. The Contractor shall comply with all schedule(s) of colors provided by the District and/or Architect.
- 1.3.2. No individual color selections will be made until after approval of all pertinent materials and equipment and after receipt of appropriate samples in accordance with the Contract Documents, including, without limitation, the provisions regarding the submittals.
- 1.3.3. Contractor shall request priority in writing for any item requiring advance ordering to maintain the approved Construction Schedule.

1.4. DELIVERY, STORAGE, AND HANDLING

- 1.4.1. Contractor shall deliver manufactured materials in original packages, containers, or bundles (with seals unbroken), bearing name or identification mark of manufacturer.
- 1.4.2. Contractor shall deliver fabrications in as large assemblies as practicable; where specified as shop-primed or shop-finished, package or crate as required to preserve such priming or finish intact and free from abrasion.
- 1.4.3. Contractor shall store materials in such a manner as necessary to properly protect them from damage. Materials or equipment damaged by handling, weather, dirt, or from any other cause will not be accepted.

- 1.4.4. Materials are not be acceptable that have been warehoused for long periods of time, stored or transported in improper environment, improperly packaged, inadequately labeled, poorly protected, excessively shipped, deviated from normal distribution pattern, or reassembled.
- 1.4.5. Contractor shall store material so as to cause no obstructions of sidewalks, roadways, and underground services. Contractor shall protect material and equipment furnished pursuant to the Contract Documents.
- 1.4.6. Contractor may store materials on Site with prior written approval by the District, all material shall remain under Contractor's control and Contractor shall remain liable for any damage to the materials. Should the Project Site not have storage area available, the Contractor shall provide for off-site storage at no cost to District.
- 1.4.7. When any room in Project is used as a shop or storeroom, the Contractor shall be responsible for any repairs, patching, or cleaning necessary due to that use. Location of storage space shall be subject to prior written approval by District.

2. PRODUCTS

2.1. MANUFACTURERS

- 2.1.1. Manufacturers listed in various sections of Contract Documents are names of those manufacturers that are believed to be capable of supplying one or more of items specified therein.
- 2.1.2. The listing of a manufacturer does not imply that every product of that manufacturer is acceptable as meeting the requirements of the Contract Documents.

2.2. FACILITIES AND EQUIPMENT

Contractor shall provide, install, maintain, and operate a complete and adequate facility for handling, the execution, disposal, and distribution of material and equipment as required for proper and timely performance of Work.

2.3. MATERIAL REFERENCE STANDARDS

Where material is specified solely by reference to "standard specifications" and if requested by District, Contractor shall submit for review data on actual material proposed to be incorporated into Work, listing name and address of vendor, manufacturer, or producer, and trade or brand names of those materials, and data substantiating compliance with standard specifications.

3. EXECUTION

3.1. WORKMANSHIP

- 3.1.1. Where not more specifically described in any other Contract Documents, workmanship shall conform to methods and operations of best standards and accepted practices of trade or trades involved and shall include items of fabrication, construction, or installation regularly furnished or required for completion (including finish and for successful operation, as intended).

- 3.1.2. Work shall be executed by tradespersons skilled in their respective field of work. When completed, parts shall have been durably and substantially built and present a neat appearance.

3.2. COORDINATION

- 3.2.1. Contractor shall coordinate installation of materials and equipment so as to not interfere with installation of other work. Adjustment or rework because of Contractor's failure to coordinate will be at no additional cost to District.
- 3.2.2. Contractor shall examine in-place materials and equipment for readiness, completeness, fitness to be concealed or to receive Work, and compliance with Contract Documents. Concealing or covering work constitutes acceptance of additional cost which will result should in-place materials and equipment be found unsuitable for receiving other work or otherwise deviating from the requirements of the Contract Documents.

3.3. COMPLETENESS

Contractor shall provide all portions of the Work, unless clearly stated otherwise, installed complete and operational with all elements, accessories, anchorages, utility connections, etc., in manner to assure well-balanced performance, in accordance with manufacturer's recommendations and in accordance with Contract Documents. For example, electric water coolers require water, electricity, and drain services; roof drains require drain system; sinks fit within countertop, etc. Terms such as "installed complete," "operable condition," "for use intended," "connected to all utilities," "terminate with proper cap," "adequately anchored," "patch and refinish," "to match similar," should be assumed to apply in all cases, except where completeness of functional or operable condition is specifically stated as not required.

3.4. APPROVED INSTALLER OR APPLICATOR

Contractor shall ensure that all installations are only performed by a manufacturer's approved installer or applicator.

3.5. MANUFACTURER'S RECOMMENDATIONS

All installations shall be in accordance with manufacturer's published recommendations and specific written directions of manufacturer's representative. Should Contract Documents differ from recommendations of manufacturer or directions of manufacturer's representative, Contractor shall analyze differences, make recommendations to the District and the Architect in writing, and shall not proceed until interpretation or clarification has been issued by the District and/or the Architect.

END OF DOCUMENT

DOCUMENT 01 66 10

DELIVERY, STORAGE AND HANDLING

1. GENERAL

1.1. RELATED DOCUMENTS AND PROVISIONS

Contractor shall review all Contract Documents for applicable provisions related to the provisions in this document, including without limitation:

- 1.1.1. General Conditions, including, without limitation, Site Access, Conditions and Requirements; and
- 1.1.2. Special Conditions.

1.2. PRODUCTS

- 1.2.1. Products are as defined in the General Conditions.
- 1.2.2. Contractor shall not use and/or reuse materials and/or equipment removed from existing Premises, except as specifically permitted by the Contract Documents.
- 1.2.3. Contractor shall provide interchangeable components of the same manufacturer, for similar components.

1.3. TRANSPORTATION AND HANDLING

- 1.3.1. Contractor shall transport and handle Products in accordance with manufacturer's instructions.
- 1.3.2. Contractor shall promptly inspect shipments to confirm that Products comply with Contract requirements, are of correct quantity, and are undamaged.
- 1.3.3. Contractor shall provide equipment and personnel to properly handle Products to prevent soiling, disfigurement, or damage.

1.4. STORAGE AND PROTECTION

- 1.4.1. Contractor shall store and protect Products in accordance with manufacturer's instructions, with seals and labels intact and legible. Contractor shall store sensitive Products in weather-tight, climate controlled enclosures.
- 1.4.2. Contractor shall place fabricated Products that are stored outside, on above-ground sloped supports.
- 1.4.3. Contractor shall provide off-site storage and protection for Products when Site does not permit on-site storage or protection.
- 1.4.4. Contractor shall cover Products subject to deterioration with impervious sheet covering and provide ventilation to avoid condensation.

- 1.4.5. Contractor shall store loose granular materials on solid flat surfaces in a well-drained area and prevent mixing with foreign matter.
- 1.4.6. Contractor shall provide equipment and personnel to store Products by methods to prevent soiling, disfigurement, or damage.
- 1.4.7. Contractor shall arrange storage of Products to permit access for inspection and periodically inspect to assure Products are undamaged and are maintained under specified conditions.

END OF DOCUMENT

DOCUMENT 01 70 10

CONTRACT CLOSEOUT AND FINAL CLEANING

1. GENERAL

1.1. RELATED DOCUMENTS AND PROVISIONS

Contractor shall review all Contract Documents for applicable provisions related to the provisions in this document, including without limitation:

- 1.1.1. General Conditions, including, without limitation, Documents on Work and Completion of Work;
- 1.1.2. Special Conditions; and
- 1.1.3. Record Documents

1.2. CLOSEOUT PROCEDURES

Contractor shall comply with all closeout provisions as indicated in the General Conditions.

1.3. FINAL CLEANING

- 1.3.1. Contractor shall execute final cleaning prior to final inspection.
- 1.3.2. Contractor shall clean interior and exterior glass and surfaces exposed to view; remove temporary labels, tape, stains, and foreign substances, polish transparent and glossy surfaces, wax and polish new vinyl floor surfaces, vacuum carpeted and soft surfaces.
- 1.3.3. Contractor shall clean equipment and fixtures to a sanitary condition.
- 1.3.4. Contractor shall replace filters of operating equipment.
- 1.3.5. Contractor shall clean debris from roofs, gutters, down spouts, and drainage systems.
- 1.3.6. Contractor shall clean Site, sweep paved areas, and rake clean landscaped surfaces.
- 1.3.7. Contractor shall remove waste and surplus materials, rubbish, and construction facilities from the Site.

1.4. ADJUSTING

Contractor shall adjust operating products and equipment to ensure smooth and unhindered operation.

1.5. RECORD DOCUMENTS AND SHOP DRAWINGS

Contractor shall legibly mark each item to record actual construction, including:

- 1.5.1. Measured depths of foundation in relation to finish floor datum.

- 1.5.2. Measured horizontal and vertical locations of underground utilities and appurtenances, referenced to permit surface improvements.
- 1.5.3. Measured locations of internal utilities and appurtenances concealed in construction, referenced to visible and accessible features of the Work.
- 1.5.4. Field changes of dimension and detail.
- 1.5.5. Details not on original Contract Drawings
- 1.5.6. Changes made by modification(s).
- 1.5.7. References to related Shop Drawings and modifications.
- 1.5.8. Contractor will provide one set of Record Drawings to District.
- 1.5.9. Contractor shall submit all required documents to District and/or Architect prior to or with its final Application for Payment.

1.6. INSTRUCTION OF DISTRICT PERSONNEL

- 1.6.1. Before final inspection, at agreed upon times, Contractor shall instruct District's designated personnel in operation, adjustment, and maintenance of products, equipment, and systems.
- 1.6.2. For equipment requiring seasonal operation, Contractor shall perform instructions for other seasons within six (6) months.
- 1.6.3. Contractor shall use operation and maintenance manuals as basis for instruction. Contractor shall review contents of manual with personnel in detail to explain all aspects of operation and maintenance.
- 1.6.4. Contractor shall prepare and insert additional data in Operation and Maintenance Manual when need for such data becomes apparent during instruction.
- 1.6.5. Contractor shall use operation and maintenance manuals as basis for instruction. Contractor shall review contents of manual with personnel in detail to explain all aspects of operation and maintenance.

1.7. SPARE PARTS AND MAINTENANCE MATERIALS

- 1.7.1. Contractor shall provide products, spare parts, maintenance, and extra materials in quantities specified in the Specifications and in Manufacturer's recommendations.
- 1.7.2. Contractor shall provide District all required Operation and Maintenance Data.

END OF DOCUMENT

DOCUMENT 01 71 10

FIELD ENGINEERING

1. GENERAL

1.1. RELATED DOCUMENTS AND PROVISIONS

Contractor shall review all Contract Documents for applicable provisions related to the provisions in this document, including without limitation:

- 1.1.1. General Conditions, including, without limitation, Site Investigation, and Soils Investigation Report;
- 1.1.2. Special Conditions; and
- 1.1.3. Site-Visit Certification.

1.2. REQUIREMENTS INCLUDED

- 1.2.1. Contractor shall provide and pay for field engineering services by a California-registered engineer, required for the Project, including, without limitations:
 - 1.2.1.1. Survey work required in execution of the Project.
 - 1.2.1.2. Civil or other professional engineering services specified, or required to execute Contractor's construction methods.

1.3. QUALIFICATIONS OF SURVEYOR OR ENGINEERS

Contractor shall only use a qualified licensed engineer or registered land surveyor, to whom District makes no objection.

1.4. SURVEY REFERENCE POINTS

- 1.4.1. Existing basic horizontal and vertical control points for the Project are those designated on the Drawings.
- 1.4.2. Contractor shall locate and protect control points prior to starting Site Work and preserve all permanent reference points during construction. In addition Contractor shall:
 - 1.4.2.1. Make no changes or relocation without prior written notice to District and Architect.
 - 1.4.2.2. Report to District and Architect when any reference point is lost or destroyed, or requires relocation because of necessary changes in grades or locations.
 - 1.4.2.3. Require surveyor to replace Project control points based on original survey control that may be lost or destroyed.

1.5. RECORDS

Contractor shall maintain a complete, accurate log of all control and survey work as it progresses.

1.6. SUBMITTALS

- 1.6.1. Contractor shall submit name and address of Surveyor and Professional Engineer to District and Architect prior to its/their work on the Project.
- 1.6.2. On request of District and Architect, Contractor shall submit documentation to verify accuracy of field engineering work, at no additional cost to the District.
- 1.6.3. Contractor shall submit a certificate signed by registered engineer or surveyor certifying that elevations and locations of improvements are in conformance or nonconformance with Contract Documents.

2. EXECUTION

2.1. COMPLIANCE WITH LAWS

Contractor is responsible for meeting all applicable codes, OSHA, safety and shoring requirements.

2.2. NONCONFORMING WORK

Contractor is responsible for any re-surveying required by correction of nonconforming work.

END OF DOCUMENT

DOCUMENT 01 73 10

CUTTING AND PATCHING

1. GENERAL

1.1. RELATED DOCUMENTS AND PROVISIONS

Contractor shall review all Contract Documents for applicable provisions related to the provisions in this document, including without limitation:

- 1.1.1. General Conditions, including, without limitation, Inspector, Inspections, and Tests, Integration of Work, Nonconforming Work, and Correction of Work, and Uncovering Work;
- 1.1.2. Special Conditions;
- 1.1.3. Hazardous Materials Procedures and Requirements;
- 1.1.4. Hazardous Materials Certification;
- 1.1.5. Lead-Based Materials Certification; and
- 1.1.6. Imported Materials Certification.

1.2. CUTTING AND PATCHING

- 1.2.1. Contractor shall be responsible for all cutting, fitting, and patching, including associated excavation and backfill, required to complete the Work or to:
 - 1.2.1.1. Make several parts fit together properly.
 - 1.2.1.2. Uncover portions of Work to provide for installation of ill-timed Work.
 - 1.2.1.3. Remove and replace defective Work.
 - 1.2.1.4. Remove and replace Work not conforming to requirements of Contract Documents.
 - 1.2.1.5. Remove Samples of installed Work as specified for testing.
 - 1.2.1.6. Provide routine penetrations of non-structural surfaces for installation of piping and electrical conduit.
 - 1.2.1.7. Attaching new materials to existing remodeling areas – including painting (or other finishes) to match existing conditions.
- 1.2.2. In addition to Contract requirements, upon written instructions from District, Contractor shall uncover Work to provide for observations of covered Work in accordance with the Contract Documents; remove samples of installed materials for testing as directed by District; and remove Work to provide for alteration of existing Work.

- 1.2.3. Contractor shall not cut or alter Work, or any part of it, in such a way that endangers or compromises the integrity of the Work, the Project, or work of others.
- 1.2.4. Contractor shall not cut and patch operating elements and safety related components in a manner that results in reducing their capacity to perform as intended or that results in increased maintenance or decreased operational life or safety. Operating elements include the following:
 - 1.2.4.1. Primary operational systems and equipment.
 - 1.2.4.2. Air or smoke barriers.
 - 1.2.4.3. Fire-suppression systems.
 - 1.2.4.4. Mechanical systems piping and ducts.
 - 1.2.4.5. Control systems.
 - 1.2.4.6. Communication systems.
 - 1.2.4.7. Conveying systems.
 - 1.2.4.8. Electrical wiring systems.
- 1.2.5. Contractor shall not cut and patch miscellaneous elements or related components in a manner that could change their load-carrying capacity, that results in reducing capacity to perform as intended, or that results in increased maintenance or decreased operational life of safety. Miscellaneous elements include the following:
 - 1.2.5.1. Water, moisture or vapor barriers.
 - 1.2.5.2. Membranes and flashings.
 - 1.2.5.3. Exterior curtain-wall construction.
 - 1.2.5.4. Equipment supports.
 - 1.2.5.5. Piping, ductwork, vessels and equipment.
 - 1.2.5.6. Noise and vibration control elements and systems.
 - 1.2.5.7. Shoring, bracing and sheeting.

1.3. SUBMITTALS

- 1.3.1. Contractor shall submit written notice to District pursuant to the applicable notice provisions of the Contract Documents, requesting consent to proceed with the cutting or alteration (Request) at least ten (10) days prior to any cutting or alterations that may affect the structural safety of Project, or work of others, including the following:
 - 1.3.1.1. The work of the District or other trades.
 - 1.3.1.2. Structural value or integrity of any element of Project.
 - 1.3.1.3. Integrity or effectiveness of weather-exposed or weather-resistant elements or systems.
 - 1.3.1.4. Efficiency, operational life, maintenance or safety of operational elements.
 - 1.3.1.5. Visual qualities of sight-exposed elements.
- 1.3.2. Contractor's Request shall also include:
 - 1.3.2.1. Identification of Project.

- 1.3.2.2. Description of affected Work.
- 1.3.2.3. Necessity for cutting, alteration, or excavations.
- 1.3.2.4. Affects of Work on District, other trades, or structural or weatherproof integrity of Project.
- 1.3.2.5. Description of proposed Work:
 - 1.3.2.5.1. Scope of cutting, patching, alteration, or excavation.
 - 1.3.2.5.2. Trades that will execute Work.
 - 1.3.2.5.3. Products proposed to be used.
 - 1.3.2.5.4. Extent of refinishing to be done.
- 1.3.2.6. Alternates to cutting and patching.
- 1.3.2.7. Cost proposal, when applicable.
- 1.3.2.8. The scheduled date the Contractor intends to perform the Work and the duration of time to complete the Work.
- 1.3.2.9. Written permission of other trades whose Work will be affected.

1.4. QUALITY ASSURANCE

- 1.4.1. Contractor shall ensure that cutting, fitting, and patching shall achieve security, strength, weather protection, appearance for aesthetic match, efficiency, operational life, maintenance, safety of operational elements, and the continuity of existing fire ratings.
- 1.4.2. Contractor shall ensure that cutting, fitting, and patching shall successfully duplicate undisturbed adjacent profiles, materials, textures, finishes, colors, and that materials shall match existing construction. Where there is dispute as to whether duplication is successful or has been achieved to a reasonable degree, the District's decision shall be final.

1.5. PAYMENT FOR COSTS

- 1.5.1. Cost caused by ill-timed or defective Work or Work not conforming to Contract Documents, including costs for additional services of the District, its consultants, including but not limited to the Construction Manager, the Architect, the Project Inspector(s), Engineers, and Agents, will be paid by Contractor and/or deducted from the Contract by the District.
- 1.5.2. District shall only pay for cost of Work if it is part of the original Contract Price or if a change has been made to the contract in compliance with the provisions of the General Conditions. Cost of Work performed upon instructions from the District, other than defective or nonconforming Work, will be paid by District on approval of written Change

Order. Contractor shall provide written cost proposals prior to proceeding with cutting and patching.

2. PRODUCTS

2.1. MATERIALS

- 2.1.1. Contractor shall provide for replacement and restoration of Work removed. Contractor shall comply with the Contract Documents and with the Industry Standard(s), for the type of Work, and the Specification requirements for each specific product involved. If not specified, Contractor shall first recommend a product of a manufacturer or appropriate trade association for approval by the District.
- 2.1.2. Materials to be cut and patched include those damaged by the performance of the Work.

3. EXECUTION

3.1. INSPECTION

- 3.1.1. Contractor shall inspect existing conditions of the Site and the Work, including elements subject to movement or damage during cutting and patching, excavating and backfilling. After uncovering Work, Contractor shall inspect conditions affecting installation of new products.
- 3.1.2. Contractor shall report unsatisfactory or questionable conditions in writing to District as indicated in the General Conditions and shall proceed with Work as indicated in the General Conditions by District.

3.2. PREPARATION

- 3.2.1. Contractor shall provide shoring, bracing and supports as required to maintain structural integrity for all portions of the Project, including all requirements of the Project.
- 3.2.2. Contractor shall provide devices and methods to protect other portions of Project from damage.
- 3.2.3. Contractor shall, provide all necessary protection from weather and extremes of temperature and humidity for the Project, including without limitation, any work that may be exposed by cutting and patching Work. Contractor shall keep excavations free from water.

3.3. ERECTION, INSTALLATION AND APPLICATION

- 3.3.1. With respect to performance, Contractor shall:
 - 3.3.1.1. Execute fitting and adjustment of products to provide finished installation to comply with and match specified tolerances and finishes.
 - 3.3.1.2. Execute cutting and demolition by methods that will prevent damage to other Work, and provide proper surfaces to receive installation of repairs and new Work.

- 3.3.1.3. Execute cutting, demolition excavating, and backfilling by methods that will prevent damage to other Work and damage from settlement.
- 3.3.1.4. Contractor shall employ original installer or fabricator to perform cutting and patching for:
- 3.3.1.5. Weather-exposed surfaces and moisture-resistant elements such as roofing, sheet metal, sealants, waterproofing, and other trades.
- 3.3.1.6. Sight-exposed finished surfaces.
- 3.3.2. Contractor shall execute fitting and adjustment of products to provide a finished installation to comply with specified products, functions, tolerances, and finishes as shown or specified in the Contract Documents including, without limitation, the Drawings and Specifications.
- 3.3.3. Contractor shall fit Work airtight to pipes, sleeves, ducts, conduit, and other penetrations through surfaces. Contractor shall conform to all Code requirements for penetrations or the Drawings and Specifications, whichever calls for a higher quality or more thorough requirement. Contractor shall maintain integrity of both rated and non-rated fire walls, ceilings, floors, etc.
- 3.3.4. Contractor shall restore Work which has been cut or removed. Contractor shall install new products to provide completed Work in accordance with requirements of the Contract Documents and as required to match surrounding areas and surfaces.
- 3.3.5. Contractor shall refinish all continuous surfaces to nearest intersection as necessary to match the existing finish to any new finish.

END OF DOCUMENT

DOCUMENT 01 74 10

DEMOLITION WASTE MANAGEMENT

1. GENERAL

1.1. RELATED DOCUMENTS AND PROVISION

Contractor shall review all Contract Documents for applicable provisions related to the provisions in this document, including without limitation:

- 1.1.1. General Conditions;
- 1.1.2. Special Conditions;
- 1.1.3. Collaborative For High Performance Schools (CHPS) -- Special Environmental Requirements; and
- 1.1.4. Closeout.

1.2. DEFINITIONS

- 1.2.1. **Construction and Demolition Waste:** Building and site improvement materials and waste materials resulting from construction and demolition or selective demolition operations.
- 1.2.2. **Disposal:** Removal off-site of demolition and construction waste and subsequent sale, recycling, reuse, or deposit in landfill or incinerator acceptable to authorities having jurisdiction.
- 1.2.3. **Recycle:** Recovery of demolition or construction waste for subsequent processing in preparation for reuse.
- 1.2.4. **Salvage:** Recovery of demolition or construction waste and subsequent sale or reuse in another facility.
- 1.2.5. **Salvage and Reuse:** Recovery of demolition or construction waste and subsequent incorporation into the Work.
- 1.2.6. **Waste Management Coordinator:** Contractor's designated representative responsible for preparation and execution of demolition waste management plan.

1.3. PERFORMANCE GOALS

- 1.3.1. **General:** Develop waste management plan that results in end-of-Project rates for salvage/recycling of seventy-five percent (75%) by weight of total waste generated by the Work.
- 1.3.2. **Salvage/Recycle Goals:** Salvage and recycle as much nonhazardous construction and demolition waste as possible. District has established a minimum goal of seventy-five percent (75%) by weight of total waste generated by the Work for the following materials:

- Demolition Soils Waste:
- Green Materials: Trees, stumps, trimmings, and land clearing debris.
- Asphaltic concrete paving.
- Concrete.
- Decorative masonry and rocks.
- Concrete reinforcing steel.
- Brick.
- Concrete masonry units.
- Wood studs, joists, and sheathing.
- Plywood and oriented strand board.
- Wood paneling.
- Wood trim.
- Interior casework.
- Structural and miscellaneous steel.
- Rough hardware.
- Roofing.
- Insulation.
- Windows, doors, and frames.
- Door hardware.
- Windows.
- Glazing.
- Metal: Ferrous and non-ferrous.
- Gypsum board.
- Acoustical tile and panels.
- Carpet.
- Carpet pad.
- Demountable partitions.
- Equipment:
 - Cabinets.
 - Plumbing fixtures.
 - Piping.
 - Supports and hangers.
 - Valves.
 - Fire sprinklers.
 - Mechanical equipment.
 - Refrigerants.
 - Electrical conduit.
 - Copper wiring.
 - Lighting fixtures.
 - Lamps.
 - Ballasts.
 - Electrical devices.
 - Switchgear and panel boards.
 - Historical items for Archive Project.

1.4. SUBMITTALS

- 1.4.1. **Waste Management Plan:** Submit five (5) copies of plan concurrent with the Schedule of Submittals as indicated in the General Conditions.

- 1.4.2. **Waste Reduction Progress Reports:** Concurrent with each Application for Payment, submit five (5) copies of reports. Include separate reports for demolition and construction waste. Include the following information:
 - 1.4.2.1. Material category;
 - 1.4.2.2. Generation point of waste;
 - 1.4.2.3. Total quantity of waste in tons;
 - 1.4.2.4. Quantity of waste salvaged, both estimated and actual in tons;
 - 1.4.2.5. Quantity of waste recycled, both estimated and actual in tons;
 - 1.4.2.6. Total quantity of waste recovered (salvaged plus recycled) in tons; and
 - 1.4.2.7. Total quantity of waste recovered (salvaged plus recycled) as a percentage of total waste.
- 1.4.3. **Forms:** Prepare waste reduction progress reports on forms included herein below.
- 1.4.4. **Waste Reduction Calculations:** Before Completion, submit five (5) copies of calculated end-of-Project rates for salvage, recycling, and disposal as a percentage of total waste generated by the Work. Contractor may request information from District to assist in preparing these calculations.
- 1.4.5. **Records of Donations:** Indicate receipt and acceptance of salvageable waste donated to individuals and organizations. Indicate whether organization is tax exempt.
- 1.4.6. **Records of Sales:** Indicate receipt and acceptance of salvageable waste sold to individuals and organizations. Indicate whether organization is tax exempt.
- 1.4.7. **Recycling and Processing Facility Records:** Indicate receipt and acceptance of recyclable waste by recycling and processing facilities licensed to accept them. Include manifests, weight tickets, receipts, and invoices.
- 1.4.8. **Landfill and Incinerator Disposal Records:** Indicate receipt and acceptance of waste by landfills and incinerator facilities licensed to accept them. Include manifests, weight tickets, receipts, and invoices.
- 1.4.9. **Qualification Data:** For Contractor's Waste Management Coordinator.
- 1.4.10. **Statement of Refrigerant Recovery:** Signed by refrigerant recovery technician responsible for recovering refrigerant, stating that all refrigerant that was present was recovered and that recovery was performed according to EPA regulations. Include name and address of technician and date refrigerant was recovered.
- 1.4.11. **Hazardous Materials Abatement:** Coordinate with other applicable Specifications for the removal of hazardous components of materials to be recycled.

1.5. QUALITY ASSURANCE

- 1.5.1. **Waste Management Coordinator:** Submit qualifications for District's approval.

- 1.5.2. **Regulatory Requirements:** Comply with hauling and disposal regulations of authorities having jurisdiction.
- 1.5.3. **Waste Management Conference:** Conduct conference at Project site to comply with requirements in Division 1 Section 01039 – Coordination and Meetings. Review methods and procedures related to waste management including, but not limited to, the following:
 - 1.5.3.1. Review and discuss waste management plan including responsibilities of Waste Management Coordinator;
 - 1.5.3.2. Review requirements for documenting quantities of each type of waste and its disposition;
 - 1.5.3.3. Review and finalize procedures for materials separation and verify availability of containers and bins needed to avoid delays;
 - 1.5.3.4. Review procedures for periodic waste collection and transportation to recycling and disposal facilities; and
 - 1.5.3.5. Review waste management requirements for each trade.
- 1.5.4. **Quality of Recycled Material for Re-Use On Site:** Coordinate with testing requirements under the appropriate sections.

1.6. WASTE MANAGEMENT PLAN

- 1.6.1. **General:** Develop plan consisting of waste identification, waste reduction work plan, and cost/revenue analysis. Include separate sections in plan for different types of demolition waste. Indicate quantities by weight or volume, but use same units of measure throughout waste management plan.
- 1.6.2. **Waste Identification:** Indicate anticipated types and quantities of demolition and site-clearing waste generated by the Work in accordance with the District as defined below. Include estimated quantities and assumptions for estimates.
 - 1.6.2.1. Fully contained, segregated hazardous materials disposal.
 - 1.6.2.1.1. Class I Hazardous Materials Landfill
 - 1.6.2.2. Reuse of building materials or salvageable items.
 - 1.6.2.2.1. Wood trim, interior casework, historical items (Archive Project).
 - 1.6.2.2.2. Windows, doors, hardware.
 - 1.6.2.2.3. Equipment.
 - 1.6.2.3. Source separation of recyclable materials.
 - 1.6.2.3.1. Asphalt.

- 1.6.2.3.2. Concrete, concrete block, decorative masonry, and rocks.
- 1.6.2.3.3. Green Materials: Trees, stumps, trimmings, and land-clearing debris.
- 1.6.2.3.4. Metal: Ferrous and non-ferrous.
- 1.6.2.3.5. Brick.
- 1.6.2.3.6. Soil.
- 1.6.2.3.7. Wood: Flooring, sheathing, structural lumber, finish lumber.
- 1.6.2.3.8. Gypsum board.
- 1.6.2.4. On-site crushing of asphalt and concrete for use on or off-site.
- 1.6.2.5. Mixed debris recycling facilities.
 - 1.6.2.5.1. For materials which cannot be feasibly separated.
 - 1.6.2.5.2. Ship to mixed materials recycling facility.
- 1.6.2.6. Waste disposal to landfill.
 - 1.6.2.6.1. For all remaining materials which cannot be recycled, reused, separated, or mixed.
 - 1.6.2.6.1.1. Ceiling tiles.
 - 1.6.2.6.1.2. Carpet.
 - 1.6.2.6.1.3. Plaster, stucco.
 - 1.6.2.6.1.4. Mixed demolition debris.
- 1.6.3. **Waste Reduction Work Plan:** List each type of waste and whether it will be salvaged, recycled, or disposed of in landfill or incinerator. Include points of waste generation, total quantity of each type of waste, quantity for each means of recovery, and handling and transportation procedures.
 - 1.6.3.1. Salvaged Materials for Reuse: For materials that will be salvaged and reused in this Project, describe methods for preparing salvaged materials before incorporation into the Work.
 - 1.6.3.2. Salvaged Materials for Sale: For materials that will be sold to individuals and organizations, include list of their names, addresses, and telephone numbers.
 - 1.6.3.3. Salvaged Materials for Donation: For materials that will be donated to individuals and organizations, include list of their names, addresses, and telephone numbers.

- 1.6.3.4. Recycled Materials: Include list of local receivers and processors and type of recycled materials each will accept. Include names, addresses, and telephone numbers.
- 1.6.3.5. Disposed Materials: Indicate how and where materials will be disposed of. Include name, address, and telephone number of each landfill and incinerator facility.
- 1.6.3.6. Handling and Transportation Procedures: Include method that will be used for separating recyclable waste including sizes of containers, container labeling, and designated location on Project site where materials separation will be located.
- 1.6.4. **Cost/Revenue Analysis:** Indicate total cost of waste disposal as if there was no waste management plan and net additional cost or net savings resulting from implementing waste management plan. Include the following:
 - 1.6.4.1. Total quantity of waste.
 - 1.6.4.2. Estimated cost of disposal (cost per unit). Include hauling and tipping fees and cost of collection containers for each type of waste.
 - 1.6.4.3. Total cost of disposal (with no waste management).
 - 1.6.4.4. Revenue from salvaged materials.
 - 1.6.4.5. Revenue from recycled materials.
 - 1.6.4.6. Savings in hauling and tipping fees by donating materials.
 - 1.6.4.7. Savings in hauling and tipping fees that are avoided.
 - 1.6.4.8. Handling and transportation costs. Include cost of collection containers for each type of waste.
 - 1.6.4.9. Net additional cost or net savings from waste management plan.
- 1.6.5. Forms: Prepare waste management plan on forms included at end of Part 3.

2. PRODUCTS

Not Used

3. EXECUTION

3.1. PLAN IMPLEMENTATION

- 3.1.1. **General:** Provide handling, containers, storage, signage, transportation, and other items as required to implement waste management plan during the entire duration of the Contract.
- 3.1.2. **Waste Management Coordinator:** Waste management coordinator shall work with representative of the District for implementing, monitoring, and reporting status of

waste management work plan. Coordinator shall be present at Project site for duration of project.

- 3.1.3. **Training:** Train workers, subcontractors, and suppliers on proper waste management procedures, as appropriate for the Work occurring at Project site.
 - 3.1.3.1. Distribute waste management plan to everyone concerned within 3 days of submittal return.
 - 3.1.3.2. Distribute waste management plan to entities when they first begin work on-site. Review plan procedures and locations established for salvage, recycling, and disposal.
- 3.1.4. **Site Access and Temporary Controls:** Conduct waste management operations to ensure minimum interference with roads, streets, walks, walkways, and other adjacent occupied and used facilities.
 - 3.1.4.1. Designate and label specific areas on Project site necessary for separating materials that are to be salvaged, recycled, reused, donated, and sold.
 - 3.1.4.2. Comply with Division 1 Section 01500 - Temporary Facilities and Controls, for controlling dust and dirt, environmental protection, and noise control.
- 3.1.5. **Weighing and Documentation:** Separate and weigh all items to be recycled or salvaged.
 - 3.1.5.1. Weight shall be measured by the ton or fraction thereof.
 - 3.1.5.2. Measurement of weight shall be by a properly calibrated scale bearing a current seal of the appropriate weights and measures representation.
 - 3.1.5.3. Measured weights shall be recorded along with all other documentation required in the forms provided.

3.2. DISPOSITION OF SALVAGED MATERIALS AND ITEMS

- 3.2.1. Salvaged Materials for Reuse in the Work:
 - 3.2.1.1. Clean or wash salvaged items.
 - 3.2.1.2. Crush and stock pile material for re-use on-site or transport off site.
 - 3.2.1.3. Stockpile materials in an area which is safe from standing water or erosion.
 - 3.2.1.4. Protect stockpiles until ready for re-use.
 - 3.2.1.5. Re-install salvaged materials to comply with installation requirements for new materials.
- 3.2.2. Salvaged Items are not permitted to be sold on Project site.
- 3.2.3. Salvaged Items shall be removed from project site for disposition at an appropriate salvage supply yard.

3.2.4. Salvaged Items for District's Use: None.

3.3. RECYCLING DEMOLITION WASTE, GENERAL

- 3.3.1. **General:** Recycle paper and beverage containers used by on-site workers.
- 3.3.2. **Waste Recycling Receivers and Processors:** Licensed entity normally engaged in the business of receiving, recycling, and processing waste materials with a minimum of 5 years of documented experience with the types of waste products to be processed under the provisions of this section.
- 3.3.3. **Recycling Incentives:** Revenues, savings, rebates, tax credits, and other incentives received for recycling waste materials shall be shared equally by District and Contractor.
- 3.3.4. **Procedures:** Separate recyclable waste from other waste materials, trash, and debris. Separate recyclable waste by type at Project site to the maximum extent practical.
 - 3.3.4.1. Provide appropriately marked containers or bins for controlling recyclable waste until they are removed from Project site. Include list of acceptable and unacceptable materials at each container and bin.
 - 3.3.4.2. Inspect containers and bins for contamination and remove contaminated materials if found.
 - 3.3.4.3. Stockpile processed materials on-site without intermixing with other materials. Place, grade, and shape stockpiles to drain surface water. Cover to prevent windblown dust.
 - 3.3.4.4. Stockpile materials away from construction area. Do not store within drip line of remaining trees.
 - 3.3.4.5. Store components off the ground and protect from the weather.
 - 3.3.4.6. Remove recyclable waste off District's property and transport to recycling receiver or processor.

3.4. RECYCLING DEMOLITION WASTE

- 3.4.1. **Bituminous Concrete Paving:** Break up and transport paving to asphalt-recycling facility, or process on-site.
- 3.4.2. **Concrete Reinforcement:** Remove reinforcement and other metals from concrete and sort with other metals.
- 3.4.3. **Concrete:** Break up and transport to concrete-recycling facility or process on site.
- 3.4.4. **Concrete:** Crush concrete and screen to comply with requirements in Division 2 Section 02300 - Earthwork: Re-use as fill at contractor's option.
- 3.4.5. **Masonry Reinforcement:** Remove metal reinforcement, anchors, and ties from masonry and sort with other metals.

- 3.4.6. **Masonry:** Crush masonry and screen to comply with requirements in Division 2 Section 02300 - Earthwork for use as satisfactory soil for fill.
- 3.4.7. **Wood Materials:** Separate lumber, engineered wood products, panel products, and treated wood materials. Dispose of as salvage or recycle for filler or mulch at an appropriate facility.
- 3.4.8. **Metals:** Separate metals by type.
 - 3.4.8.1. Structural Steel and Other Metals: Separate members according to size, type of member, and length.
 - 3.4.8.2. Recycle bolts, nuts, washers, and other rough hardware.
 - 3.4.8.3. Non-Ferrous Metals: Separate by type.
- 3.4.9. **Asphalt Shingle Roofing:** Separate organic and glass-fiber asphalt shingles and felts. Remove and dispose of nails, staples, and accessories.
- 3.4.10. **Gypsum Board:** Stack large clean pieces on wood pallets and store in a dry location. Remove edge trim and sort with other metals. Remove and dispose of fasteners.
- 3.4.11. **Acoustical Ceiling Panels and Tile:** Stack large clean pieces on wood pallets and store in a dry location.
- 3.4.12. **Acoustical Ceiling Suspension Systems:** Separate suspension system, trim, and other metals from panels and tile and sort with other metals.
- 3.4.13. **Carpet and Pad:** Roll large pieces tightly after removing debris, trash, adhesive, and tack strips.
- 3.4.14. **Equipment: Drain tanks, piping, and fixtures:** Seal openings with caps or plugs. Protect equipment from exposure to weather. Sort and recycle by types of metal.
- 3.4.15. **Plumbing Fixtures:** Separate and recycle.
- 3.4.16. **Piping:** Reduce piping to straight lengths and arrange by type and size. Separate supports, hangers, valves, sprinklers, and other components by type and size.
- 3.4.17. **Lighting Fixtures:** Remove lamps and separate fixtures by type and protect from breakage and weather.
- 3.4.18. **Electrical Devices:** Separate switches, receptacles, switchgear, transformers, meters, panelboards, circuit breakers, and other devices by type.
- 3.4.19. **Conduit:** Reduce conduit to straight lengths and store by type and size.
- 3.4.20. **Green Materials:** Separate out roots, stumps, trunks, shrubs, mulch, and other green matter and transport off-site for appropriate processing.

3.5. DISPOSAL OF WASTE

- 3.5.1. **General:** Except for items or materials to be salvaged, recycled, or otherwise reused, remove waste materials from Project site and legally dispose of them in a landfill or incinerator acceptable to authorities having jurisdiction.
- 3.5.2. Do not allow waste materials that are to be disposed of accumulate on-site. Remove and transport debris in a manner that will prevent spillage on or off site.
- 3.5.3. **Burning:** Do not burn and waste materials on-site.
- 3.5.4. **Disposal:** Transport waste materials off site and legally dispose of them.

3.6. FORMS

Waste Management Plan Forms Attached:

- 3.6.1. Demolition Waste Reduction Progress Report.
- 3.6.2. Demolition Waste Identification.
- 3.6.3. Demolition Waste Reduction Work Plan.
- 3.6.4. Cost/Revenue Analysis of Demolition Waste Reduction Work Plan.

END OF DOCUMENT

Lighting Ballasts									
Electrical Devices									
Switchgear and Panel boards									
Transformers									
Historical Items									

DEMOLITION WASTE IDENTIFICATION									
MATERIAL DESCRIPTION	EST. QUANTITY	EST. VOLUME CY	EST. WEIGHT TONS	REMARKS AND ASSUMPTIONS					
Asphaltic Concrete Paving									
Concrete									
Brick									
CMU									
Lumber									
Plywood and OSB									
Wood Paneling									
Wood Trim									
Miscellaneous Metals									
Structural Steel									
Rough Hardware									
Insulation									
Roofing									
Doors, Frames, and Trim									
Door Hardware									
Windows and Trim									
Glazing									
Acoustical Tile									
Carpet									
Carpet Pad									
Demountable Partitions									
Equipment									
Cabinets									
Plumbing Fixtures									
Piping									
Piping Supports and Hangers									
Valves									
Sprinklers									
Mechanical Equipment									
Electrical Conduit									

Copper Wiring					
Light Fixtures					
Lamps					
Lighting Ballasts					
Electrical Devices					
Switchgear and Panelboards					
Transformers					
Historical Items					

DEMOLITION WASTE REDUCTION WORK PLAN						
MATERIAL CATEGORY	GENERATION POINT	TOTAL EST. QUANTITY OF WASTE TONS	DISPOSAL METHOD AND QUANTITY			HANDLING & TRANSPORTION PROCEDURES
			EST. AMOUNT SALVAGED TONS	EST. AMOUNT RECYCLED TONS	EST. AMOUNT DISPOSED TO LAND FILL TONS	
Asphaltic Concrete Paving						
Concrete						
Brick						
CMU						
Lumber						
Plywood and OSB						
Wood Paneling						
Wood Trim						
Miscellaneous Metals						
Structural Steel						
Rough Hardware						
Insulation						
Roofing						
Doors, Frames, and Trim						
Door Hardware						
Windows and Trim						
Glazing						
Acoustical Tile						
Carpet						
Carpet Pad						
Demountable Partitions						
Equipment						
Cabinets						
Plumbing Fixtures						
Piping						
Supports and Hangers						
Valves						
Sprinklers						
Mechanical Equipment						
Electrical Conduit						
Copper Wiring						
Light Fixtures						
Lamps						

DOCUMENT 01 78 23

OPERATION AND MAINTENANCE DATA

1. GENERAL

1.1. RELATED DOCUMENTS AND PROVISIONS

Contractor shall review all Contract Documents for applicable provisions related to the provisions in this document, including without limitation:

- 1.1.1. General Conditions, including, without limitation, Completion of the Work;
- 1.1.2. Special Conditions; and
- 1.1.3. Contract Forms and Submittals.

1.2. QUALITY ASSURANCE

Contractor shall prepare instructions and data by personnel experienced in maintenance and operation of described products.

1.3. FORMAT

- 1.3.1. Contractor shall prepare data in the form of an instructional manual entitled "OPERATIONS AND MAINTENANCE MANUAL & INSTRUCTIONS" ("Manual").
- 1.3.2. Binders: Contractor shall use commercial quality, 8-1/2 by 11 inch, three-side rings, with durable plastic covers; two inch maximum ring size. When multiple binders are used, Contractor shall correlate data into related consistent groupings.
- 1.3.3. Cover: Contractor shall identify each binder with typed or printed title "OPERATION AND MAINTENANCE MANUAL & INSTRUCTIONS"; and shall list title of Project and identify subject matter of contents.
- 1.3.4. Contractor shall arrange content by systems process flow under section numbers and sequence of Table of Contents of the Contract Documents.
- 1.3.5. Contractor shall provide tabbed fly leaf for each separate Product and system, with typed description of Product and major component parts of equipment.
- 1.3.6. Text: The content shall include Manufacturer's printed data, or typewritten data on 24 pound paper.
- 1.3.7. Drawings: Contractor shall provide with reinforced punched binder tab and shall bind in with text; folding larger drawings to size of text pages.

1.4. CONTENTS, EACH VOLUME

- 1.4.1. Table of Contents: Contractor shall provide title of Project; names, addresses, and telephone numbers of the Architect, any engineers, subconsultants, Subcontractor(s),

and Contractor with name of responsible parties; and schedule of Products and systems, indexed to content of the volume.

- 1.4.2. For Each Product or System: Contractor shall list names, addresses, and telephone numbers of Subcontractor(s) and suppliers, including local source of supplies and replacement parts.
- 1.4.3. Product Data: Contractor shall mark each sheet to clearly identify specific Products and component parts, and data applicable to installation. Delete inapplicable information.
- 1.4.4. Drawings: Contractor shall supplement Product data to illustrate relations of component parts of equipment and systems, to show control and flow diagrams. Contractor shall not use Project Record Documents as maintenance drawings.
- 1.4.5. Text: The Contractor shall include any and all information as required to supplement Product data. Contractor shall provide logical sequence of instructions for each procedure, incorporating manufacturer's instructions.

1.5. MANUAL FOR MATERIALS AND FINISHES

- 1.5.1. Building Products, Applied Materials, and Finishes: Contractor shall include Product data, with catalog number, size, composition, and color and texture designations. Contractor shall provide information for re-ordering custom manufactured Products.
- 1.5.2. Instructions for Care and Maintenance: Contractor shall include Manufacturer's recommendations for cleaning agents and methods, precautions against detrimental agents and methods, and recommended schedule for cleaning and maintenance.
- 1.5.3. Moisture Protection and Weather Exposed Products: Contractor shall include Product data listing applicable reference standards, chemical composition, and details of installation. Contractor shall provide recommendations for inspections, maintenance, and repair.
- 1.5.4. Additional Requirements: Contractor shall include all additional requirements as specified in the Specifications.
- 1.5.5. Contractor shall provide a listing in Table of Contents for design data, with tabbed fly sheet and space for insertion of data.

1.6. MANUAL FOR EQUIPMENT AND SYSTEMS

- 1.6.1. Each Item of Equipment and Each System: Contractor shall include description of unit or system, and component parts and identify function, normal operating characteristics, and limiting conditions. Contractor shall include performance curves, with engineering data and tests, and complete nomenclature, and commercial number of replaceable parts.
- 1.6.2. Panelboard Circuit Directories: Contractor shall provide electrical service characteristics, controls, and communications.
- 1.6.3. Contractor shall include color coded wiring diagrams as installed.

- 1.6.4. Operating Procedures: Contractor shall include start-up, break-in, and routine normal operating instructions and sequences. Contractor shall include regulation, control, stopping, shut-down, and emergency instructions. Contractor shall include summer, winter, and any special operating instructions.
- 1.6.5. Maintenance Requirements: Contractor shall include routine procedures and guide for trouble-shooting; disassembly, repair, and reassembly instructions; and alignment, adjusting, balancing, and checking instructions.
- 1.6.6. Contractor shall provide servicing and lubrication schedule, and list of lubricants required.
- 1.6.7. Contractor shall include manufacturer's printed operation and maintenance instructions.
- 1.6.8. Contractor shall include sequence of operation by controls manufacturer.
- 1.6.9. Contractor shall provide original manufacturer's parts list, illustrations, assembly drawings, and diagrams required for maintenance.
- 1.6.10. Contractor shall provide control diagrams by controls manufacturer as installed.
- 1.6.11. Contractor shall provide Contractor's coordination drawings, with color coded piping diagrams as installed.
- 1.6.12. Contractor shall provide charts of valve tag numbers, with location and function of each valve, keyed to flow and control diagrams.
- 1.6.13. Contractor shall provide list of original manufacturer's spare parts, current prices, and recommended quantities to be maintained in storage.
- 1.6.14. Additional Requirements: Contractor shall include all additional requirements as specified in Specification(s).
- 1.6.15. Contractor shall provide a listing in Table of Contents for design data, with tabbed fly sheet and space for insertion of data.

1.7. SUBMITTAL

- 1.7.1. Concurrent with the Schedule of Submittals as indicated in the General Conditions, Contractor shall submit to the District for review two (2) copies of a preliminary draft of proposed formats and outlines of the contents of the Manual.
- 1.7.2. For equipment, or component parts of equipment put into service during construction and to be operated by District, Contractor shall submit draft content for that portion of the Manual within ten (10) days after acceptance of that equipment or component.
- 1.7.3. On or before the Contractor submits its final application for payment, Contractor shall submit two (2) copies of a complete Manual in final form. The District will provide comments to Contractor and Contractor must revise the content of the Manual as required by District prior to District's approval of Contractor's final Application for Payment.

- 1.7.4. Contractor must submit two (2) copies of revised Manual in final form within ten (10) days after receiving District's comments. Failure to do so will be a basis for the District withholding funds sufficient to protect itself for Contractor's failure to provide a final Manual to the District.

END OF DOCUMENT

DOCUMENT 01 78 36

WARRANTIES

1. GENERAL

1.1. RELATED DOCUMENTS AND PROVISIONS

Contractor shall review all Contract Documents for applicable provisions related to the provisions in this document, including without limitation:

- 1.1.1. General Conditions, including, without limitation, Warranty/Guarantee/Indemnity;
- 1.1.2. Special Conditions; and
- 1.1.3. Operation and Maintenance Data

1.2. FORMAT

- 1.2.1. Binders: Contractor shall use commercial quality, 8-1/2 by 11 inch, three-side rings, with durable plastic covers; two inch maximum ring size.
- 1.2.2. Cover: Contractor shall identify each binder with typed or printed title "WARRANTIES" and shall list title of Project.
- 1.2.3. Table of Contents: Contractor shall provide title of Project; name, address, and telephone number of Contractor and equipment supplier, and name of responsible principal. Contractor shall identify each item with the number and title of the specific Specification, document, provision, or section in which the name of the Product or work item is specified.
- 1.2.4. Contractor shall separate each warranty with index tab sheets keyed to the Table of Contents listing, providing full information and using separate typed sheets as necessary. Contractor shall list each applicable and/or responsible Subcontractor(s), supplier(s), and/or manufacturer(s), with name, address, and telephone number of each responsible principal(s).

1.3. PREPARATION

- 1.3.1. Contractor shall obtain warranties, executed in duplicate by each applicable and/or responsible subcontractor(s), supplier(s), and manufacturer(s), within ten (10) days after completion of the applicable item or work. Except for items put into use with District's permission, Contractor shall leave date of beginning of time of warranty until the date of completion is determined.
- 1.3.2. Contractor shall verify that warranties are in proper form, contain full information, and are notarized, when required.
- 1.3.3. Contractor shall co-execute submittals when required.
- 1.3.4. Contractor shall retain warranties until time specified for submittal.

1.4. TIME OF SUBMITTALS

- 1.4.1. For equipment or component parts of equipment put into service during construction with District's permission, Contractor shall submit a draft warranty for that equipment or component within ten (10) days after acceptance of that equipment or component.
- 1.4.2. On or before the Contractor submits its final application for payment, Contractor shall submit all warranties and related documents in final form. The District will provide comments to Contractor and Contractor must revise the content of the warranties as required by District prior to District's approval of Contractor's final Application for Payment.
- 1.4.3. For items of Work that are not completed until after the date of Completion, Contractor shall provide an updated warranty for those item(s) of Work within ten (10) days after acceptance, listing the date of acceptance as start of warranty period.

END OF DOCUMENT

DOCUMENT 01 78 39

RECORD DOCUMENTS

1. GENERAL

1.1. RELATED DOCUMENTS AND PROVISIONS

Contractor shall review all Contract Documents for applicable provisions related to the provisions in this document, including without limitation:

- 1.1.1. General Conditions, including, without limitation, Documents on Work and Completion of Work;
- 1.1.2. Special Conditions; and
- 1.1.3. Contract Closeout and Final Cleaning.

2. RECORD DRAWINGS

2.1. GENERAL

- 2.1.1. "Record Drawings" may also be referred to in the Contract Documents as "As-Built Drawings."
- 2.1.2. As indicated in the Contract Documents, District will provide Contractor with one set of reproducible plans of the original Contract Drawings.
- 2.1.3. Contractor shall maintain at each Project Site one (1) set of marked-up plans and shall transfer all changes and information to those marked-up plans, as often as required in the Contract Documents, but in no case less than once each month. Contractor shall submit to the Project Inspector one set of reproducible vellums of the Project Record Drawings ("As-Builts") showing all changes incorporated into the Work since the preceding monthly submittal. The As-Builts shall be available at the Project Site. The Contractor shall submit reproducible vellums at the conclusion of the Project following review of the blueline prints.
- 2.1.4. Label and date each Record Drawing "RECORD DOCUMENT" in legibly printed letters.
- 2.1.5. All deviations in construction, including but not limited to pipe and conduit locations and deviations caused by without limitation Change Orders, Construction Directives, RFI's, and Addenda, shall be accurately and legibly recorded by Contractor.
- 2.1.6. Locations and changes shall be done by Contractor in a neat and legible manner and, where applicable, indicated by drawing a "cloud" around the changed or additional information.

2.2. RECORD DRAWING INFORMATION

- 2.2.1. Contractor shall record the following information:
 - 2.2.1.1. Locations of Work buried under or outside each building, including, without limitation, all utilities, plumbing and electrical lines, and conduits.

- 2.2.1.2. Actual numbering of each electrical circuit.
- 2.2.1.3. Locations of significant Work concealed inside each building whose general locations are changed from those shown on the Contract Drawings.
- 2.2.1.4. Locations of all items, not necessarily concealed, which vary from the Contract Documents.
- 2.2.1.5. Installed location of all cathodic protection anodes.
- 2.2.1.6. Deviations from the sizes, locations, and other features of installations shown in the Contract Documents.
- 2.2.1.7. Locations of underground work, points of connection with existing utilities, changes in direction, valves, manholes, catch basins, capped stubouts, invert elevations, etc.
- 2.2.1.8. Sufficient information to locate Work concealed in each building with reasonable ease and accuracy.
- 2.2.2. In some instances, this information may be recorded by dimension. In other instances, it may be recorded in relation to the spaces in the building near which it was installed.
- 2.2.3. Contractor shall provide additional drawings as necessary for clarification.
- 2.2.4. Contractor shall provide reproducible record drawings, made from final Shop Drawings marked "No Exceptions Taken" or "Approved as Noted."

3. RECORD SPECIFICATIONS

Contractor shall mark each section legibly to record manufacturer, trade name, catalog number, and supplier of each Product and item of equipment actually installed.

4. MAINTENANCE OF RECORD DOCUMENTS

- 4.1. Contractor shall store Record Documents apart from documents used for construction as follows:
 - 4.1.1. Provide files and racks for storage of Record Documents.
 - 4.1.2. Maintain Record Documents in a clean, dry, legible condition and in good order.
- 4.2. Contractor shall not use Record Documents for construction purposes.

END OF DOCUMENT

DOCUMENT 01 91 00

COMMISSIONING

1. GENERAL

1.1. RELATED DOCUMENTS AND PROVISIONS

Contractor shall review all Contract Documents for applicable provisions related to the provisions in this document, including without limitation:

- 1.1.1. General Conditions, including, without limitation, Documents on Work and Completion of Work;
- 1.1.1. General Conditions;
- 1.1.2. Special Conditions;
- 1.1.3. Collaborative For High Performance Schools (CHPS) -- Special Environmental Requirements; and
- 1.1.2. Contract Closeout and Final Cleaning.

1.2. SUMMARY

- 1.2.1. Commissioning is a process for validating and documenting that the facility and its systems are constructed and perform in conformity with the Contract Documents.
- 1.2.2. The objective of the commissioning process is to verify that the performance of the facility and its systems meet or exceed the design intent.
- 1.2.3. Commissioning includes special facility start-up processes used to bring the facility to a fully operational state, free of deficiencies in an efficient and timely manner.
- 1.2.4. Training on related systems and equipment operation and maintenance shall be scheduled to commence only after start-up is complete and systems are verified to be 100% complete and functional.

1.3. DESCRIPTION

The following applies to all Contract Documents:

- 1.3.1. **Contractor Startup:** Sub-phase of Contractor's work ending with Acceptance of Work, during which Contractor performs a pre-planned program of activities including starting, testing, inspecting, adjusting balancing, correcting deficiencies and other similar activities.
 - 1.3.1.1. The District, Construction Manager and Architect and the Inspector shall be present to observe, inspect and identify deficiencies in building systems operations.

- 1.3.2. The completion of startup means the entire Construction Project including startup and fine tuning has been performed to the requirements of the Contract Documents and is verified in writing by the District, Construction Manager and Architect.
- 1.3.3. **Fine Tuning:** Fine tuning is the responsibility of Contractors after District occupancy and ending one (1) year after District occupancy. During this time the Contractor is responsible for optimizing systems and correcting deficiencies arising under normal operating conditions.
 - 1.3.3.1. Includes a period after occupancy where systems are optimized under "live" operating conditions and any outstanding construction deficiencies are corrected.
 - 1.3.3.2. Fine Tuning shall extend from date of District occupancy to one year after occupancy.

1.4. DEFINITION OF TERMS

- 1.4.1. **Contractor's Pre-Commissioning Checklists:** Includes installation and start-up items as specified to be completed by the appropriate contractors prior to operational verification through the functional testing process.
- 1.4.2. **Installation Verification Process:** Includes the on-site inspection and review of related system components for conformance to Contract Documents. The Contractor shall verify systems readiness for functional testing procedures prior to the start of functional testing. Deficiencies will be documented by the Inspector for future resolution.
- 1.4.3. **Functional Performance Testing Process:** Includes the documented testing of system parameters, under actual or simulated operating conditions. Final performance commissioning of systems will begin only after the appropriate Contractor certifies that systems are 100% complete and ready for functional testing. The Contractor will be required to schedule, coordinate and perform device tests, calibration and functional performance test procedures.
- 1.4.4. **Deficiencies and Resolutions List:** Includes a list of noted deficiencies discovered as a result of the commissioning process. This list also includes the current disposition of issues, and the date of final resolution as confirmed by the Construction Manager and Inspector. Deficiencies are defined as those issues where products execution or performance does not satisfy the Project Contract Documents and/or the design intent.

1.5. COMMISSIONING SCHEDULE

- 1.5.1. Provide schedules for Contractor Start-Up work.
- 1.5.2. Incorporate in overall construction schedule.
- 1.5.3. Contractor's activities, which will be performed as specified under Fine Tuning, shall be completed within one (1) year from date of occupancy by the District.

1.6. SUBMITTALS

- 1.6.1. Submit Draft and Final Contractor Start-up Forms as described in this Document. Submit Draft Report for Construction Manager and Architect's review and comment prior to Final Submission. Submit Final Report not later than twenty weeks before scheduled date of Acceptance of Work.
- 1.6.2. Prepare and submit one copy of report form to be used in preparation of system reports for:
 - 1.6.2.1. Food Service Equipment.
 - 1.6.2.2. Gymnasium Equipment and Scoreboards
 - 1.6.2.3. Laboratory Fume Hoods
 - 1.6.2.4. Elevators
 - 1.6.2.5. Each mechanical system in the Contract Documents.
 - 1.6.2.6. Each Electrical system in the Contract Documents.
- 1.6.3. Each System Report shall be submitted including the following:
 - 1.6.3.1. Project Name
 - 1.6.3.2. Name of System
 - 1.6.3.3. Index of report's content
 - 1.6.3.4. Adjacent to list of equipment, columns to indicate status of equipment operation, to date and to sign off equipment start-up.
 - 1.6.3.5. Space to record equipment and operational problems which cannot be corrected with scheduled Contractor Start-Up program and which may delay Acceptance of Work.
 - 1.6.3.6. Manufacturer's equipment start-up reports.
 - 1.6.3.7. Systems' testing, balancing, and adjusting reports.
 - 1.6.3.8. Equipment Report Forms shall include the following: Project name, name of equipment, starting and testing procedures to be performed and observations and test results to be recorded.

1.7. COMMISSIONING DUTIES AND RESPONSIBILITIES

- 1.7.1. Contractor Duties and Responsibilities:
 - 1.7.1.1. Assure the participation and cooperation of Subcontractors and Suppliers under their jurisdictions as required to complete the commissioning process.
 - 1.7.1.2. Complete Commissioning Report Forms. Reports are to be completed in a neat easily readable condition.

1.7.1.3. Complete the respective start-up and check out procedures and insure readiness of equipment and systems prior to the start of the functional performance testing. Written confirmation of system readiness for performance testing is required.

1.7.1.4. Provide qualified representatives for the functional performance commissioning process.

1.7.1.5. Assure that all subcontractors, suppliers, test and balance, controls, etc. include in their respective contracts cost necessary to participate in and complete the commissioning process.

1.7.2. **Duties and Responsibilities of Others for Commissioning:** The commissioning process requires the active participation of the Construction Manager, District, Architect and any other related Consultants on the project.

1.8. SYSTEM FAILURES

After a second failure of a system to successfully meet the criteria as set for in the functional performance testing process, the Contractor shall reimburse the District for cost associated with any additional retesting required due to uncorrected deficiencies. Costs shall include salary, benefits, overhead, travel costs and per diem lodging costs if applicable.

END OF DOCUMENT

**SECTION 02072
MINOR DEMOLITION FOR REMODELING**

PART 1 – GENERAL

1.01 SECTION INCLUDES

- A. Provide all required demolition necessary to facilitate new construction.
- B. Removal of designated construction.
- C. Identification of utilities.

1.02 RELATED SECTIONS

- A. Section 00 70 00: General Conditions.
- B. Exhibits C, D, E Abatement of Hazardous Materials.
- C. Section 01 73 10: Cutting and Patching.
- D. Section 01 50 00: Temporary Facilities and Controls.
- E. Section 01 56 39: Temporary Tree and Plant Protection.

1.03 PROJECT RECORD DOCUMENTS

- A. Submit under provisions of Section 01 33 00.
- B. Accurately record actual utility locations, capped utilities and subsurface obstructions.

1.04 REGULATORY REQUIREMENTS

- A. Conform to all applicable codes for demolition work, safety of structure, dust control and safety of occupants.
- B. Do not close or obstruct egress width to exits.
- C. Do not disable or disrupt building fire safety systems without 72-hour prior written notice to and approval from Construction Manager.
- D. Removal of all Hazardous Material must be performed in strict conformance with contract requirements as set forth in Exhibits C, D, and E, Abatement of Hazardous Materials.

1.05 SEQUENCING

- A. Sequence work in accordance with the contractor's use of the premises under the provisions of Section 00 70 00.

1.06 SCHEDULING

- A. Schedule work under the provisions of Section 01 32 16.

- B. Describe demolition removal procedures and schedule.
- C. Perform all work between the hours of 7:00 a.m. and 4:00 p.m. except as required for abatement of hazardous materials and power outages.

1.07 SUBMITTALS

- A. Provide schedule indicating proposed sequence of operations for selective demolition work prior to start of work. Include coordination for shutoff, capping, and continuation of utility services as required, together with details for dust and noise control protection.
 - 1. Provide detailed sequence of demolition and removal work to ensure uninterrupted progress of Owner's on-site operations.
 - 2. Coordinate with Owner's continuing occupation of portions of existing building.
- B. Photograph existing conditions of structure surfaces, equipment, and adjacent improvements that might be misconstrued as damage related to removal operations. File with the Construction Manager prior to start of work.

1.08 JOB CONDITIONS

- A. Occupancy: Owner will occupy portions of the building immediately adjacent to areas of selective demolition. Conduct selective demolition work in accordance with approved demolition sequence and in a manner that will minimize need for disruption of Owner's normal operations. Provide minimum of 72-hours advanced notice to Construction Manager of demolition activities that will affect adjacent occupancy.
- B. Condition of Structures: Owner assumes no responsibility for actual condition of items or structures to be demolished.
 - 1. Conditions existing at time of inspection for bidding purposes will be maintained by Owner. However, minor variations within structure may occur by Owner's removal and salvage operations prior to start of work.
- C. Protection: Provide temporary barricades and other forms of protection to protect occupants and public from injury.
 - 1. Provide protective measures as required to provide free and safe passage of Owner's personal and students to occupied portions of campus.
 - 2. Erect temporary covered passageways as required per CBC.
 - 3. Provide interior and exterior shoring, bracing and support to prevent movement, settlement, or collapse of structure or element to be demolished and adjacent facilities or work to remain.
 - 4. Protect from damage existing finish work that is to remain.
 - 5. Construct temporary dustproof partitions where required to separate areas of work from occupants. Refer to paragraph 3.01 B for partition construction.
 - 6. Provide temporary weather protection until final construction is completed.

7. Remove all temporary protection when work is complete.
- D. Damages: Promptly repair damages caused to adjacent facilities by demolition work.
- E. Traffic: Conduct all demolition work and debris removal in a manner which minimizes interference with pedestrian and vehicle traffic.
 1. Do not close, block, or otherwise obstruct streets, walks, paths of required exits, or other occupied areas without prior written permission from Construction Manger. Provide alternate routes around closure as required to provide safe passage.
- F. Flame cutting: Do not use cutting torches for removal until work area is cleared of all flammable materials. At concealed spaces, verify condition of hidden space prior to starting work. Have present a fully charged, operational fire extinguisher during all flame cutting operations.
- G. Utility Services: Maintain existing utilities to remain in service and protect from damage during demolition operations.
 1. Do not interrupt utilities serving occupied areas except with prior approval from the Construction Manager. Provide temporary services during interruptions to existing utilities.
 2. Maintain fire protection services during demolition operations.
- H. Environmental controls: use water sprinkling, temporary enclosures, and other methods to limit dust and dirt migration. Comply with all governing regulations pertaining to environmental protection.
 1. Do not use water when it may create hazardous or objectionable conditions.
- I. Inspections:
 1. Prior to start of demolition work, make inspection, report and record defects and structural weaknesses of areas to be demolished as well as adjacent areas. If unsatisfactory conditions exist, do not commence demolition operations until appropriate determinations have been made by Construction Manager.
 2. As demolition work progresses, make periodic inspections of structure for adverse conditions and damage. Immediately notify Construction Manager if damage is observed and stop operations at that location until proper determinations have been made.
 3. Following demolition, make inspection and report any found defects, damages or structural weaknesses to Construction Manager.
 4. The Construction Manager, Inspector and the Architect will accompany the Contractor on his inspections before and after demolition to confirm the physical condition of structure and improvements.
- J. Salvaged Items: For all components identified on the Drawings or otherwise indicated by Owner/Construction Manager to be salvaged, take care in the removal of components as not to damage it. Make arrangements with Owner/Construction Manager for the temporary storage and transfer of all salvaged items and protect until transfer has been made.

PART 2 – PRODUCTS

Not Used

Mt. Diablo Unified School District

Bid # xxx

Building S Science Lab Modernization at Mt. Diablo High School

Section 02 41 00 - Page 3

Demolition

PART 3 – EXECUTION

3.01 PREPARATION

- A. Provide, erect and maintain temporary barriers at required locations.
- B. Erect and maintain dust-proof partitions and closures as required to prevent spread of dust, fumes, and noise and to permit safe separation for occupants.
 - 1. Construct temporary partitions of a minimum 4 inch studs, 5/8 inch drywall (with taped joints) on occupied side and 1/2 inch fire retardant plywood on demolition side. Fill stud cavity with sound deadening insulation.
 - 2. Provide weatherproof closure for exterior openings as required.
- C. Protect existing materials and finishes which are not to be demolished.
- D. Prevent movement of structure; provide required bracing and shoring.
- E. Mark location of utilities.

3.02 DEMOLITION REQUIREMENTS

- A. Conduct demolition to minimize interference with adjacent and occupied building areas.
- B. Cease operations immediately if structure appears to be in danger. Notify Architect. Do not resume operations until directed.
- C. Maintain protected egress and access to the Work.

3.03 DEMOLITION

- A. Disconnect, remove, cap and identify designated utilities within demolition areas.
- B. Demolish in an orderly and careful manner. Protect existing supporting structural members and materials.
- C. Remove from site all items shown or noted to be demolished and dispose of at a legal dump site. Debris shall not be stockpiled on site.
- D. Remove demolished materials from site as work progresses. Upon completion of work, leave areas in clean condition.
- E. Remove temporary Work.

3.04 ROOFING DEMOLITION

- A. Do not remove more roofing than can be re-roofed the following day.
- B. Existing roofing may contain asbestos and if so, must be removed in strict conformance with the contract requirements for asbestos abatement. **Reference Exhibit C - Asbestos Abatement Specifications/Procedures.**

3.05 RECONDITIONING EXISTING SUBSTRATES

- A. Clean surfaces on which new materials will be installed. Remove all adhesives, bitumen and other materials as necessary to provide an acceptable substrate for new materials.
- B. Perform sandblasting, chipping, grinding, acid washing, etching, and other work as required by conditions encountered and new materials involved.
- C. Use of acids or other cleaning agents shall include neutralizing, washing, rinsing, and drying, as applicable.
- D. Determine substrate requirements for reconditioned surfaces in cooperation with the manufacturer's representative and installer of each new material involved.
- E. Prepare existing concrete surfaces to receive new cast-in-place concrete by roughening, to the extent that the entire surface has a moderate to heavy broken or fractured texture, except for keyed joint, which require the exposure of coarse aggregate.
- F. Inspect existing wood roof sheathing and metal decking for possible structural defects and report any found defects to Construction Manager. All Structural repairs are to be made as directed by Architect on a time and material basis under allowance provided on Proposal Form.

3.06 MECHANICAL PIPING DEMOLITION

- A. Existing mechanical pipe wrap may contain asbestos and if so, must be removed in strict conformance with the contract requirements for asbestos abatement. **Reference Exhibit C - Asbestos Abatement Specifications/Procedures.**

3.07 CLEANUP AND REPAIR

- A. All areas of demolition must be left clean.

END OF SECTION

**SECTION 03 30 00
CONCRETE WORK**

The General Conditions, Supplementary Conditions and Division 1 General Requirements are hereby made a part of this Section as fully as if repeated herein.

PART 1 – GENERAL

1.01 SECTION INCLUDES

- A. Concrete Formwork.
- B. Reinforcement of Concrete.
- C. Concrete Placing and Finishing.
- D. Concrete Flatwork.

1.02 RELATED SECTIONS

- A. Section 00 70 00: General Conditions.
- B. Section 31 23 00: Excavation and Fill.

1.03 REFERENCES

- A. Chapter 19A, CBC(latest edition)
- B. ACI 211.1 - Standard Practice for Selecting Proportions for Normal Weight, Heavy Weight and Mass Concrete.
- C. ACI 301 - Specifications for Structural Concrete for Buildings.
- D. ACI 304R - Guide for Measuring, Mixing, Transporting and Placing Concrete.
- E. ACI 305R - Hot Weather Concreting.
- F. ACI 306R - Cold Weather Concreting.
- G. ACI 308 - Standard Practice for Curing Concrete.
- H. ACI 309R - Guide for Consolidation of Concrete.
- I. ACI 318 - Building Code Requirements for Structural Concrete.
- J. ASTM A615 / A615M – 09b - Deformed and Plain Billet Steel Bars for Concrete Reinforcement.
- K. ASTM C33 / C33M-08 - Concrete Aggregates.
- L. ASTM C94 / C94M –09a - Ready-Mixed Concrete.
- M. ASTM C114- 09b - Methods of Chemical Analysis of Hydraulic Cement.
- N. ASTM C150 / C150M-09 - Portland Cement.

- O. ASTM C260-06 - Air Entraining Admixtures.
- P. ASTM C494 / C49M-08a - Water Reducing Admixtures.

1.04 QUALITY ASSURANCE

- A. All Concrete for the project shall be controlled concrete of specified strengths, of uniform color, and free from defects liable to adversely affect strength, durability or appearance of the structure or its components.
- B. Requirements of Regulatory Agencies: The quality and design of structural concrete shall comply with the requirements of the California Building Code, except where more stringent requirements are specified.
- C. Workmanship: Materials and methods used for the production and placement of concrete shall be such as to assure the specified quality and shall conform to applicable requirements of the Building Code for Reinforced Concrete (ACI 318) of the American Concrete Institute, except as otherwise specified in this Section.
 - 1. Proper installation of partitions and equipment requires the floor finish to be level and smooth throughout. Extreme care shall be exercised during all floating and troweling operations to check levels often.
 - 2. Any concrete work which does not comply with tolerances and elevations shown on drawings will be cause for rejection of all work affected, and, if so rejected, such work shall be removed and replaced at no increase in cost to the Owner.
- D. Repair of Defective Concrete Surfaces shall be done in the following manner when, in the opinion of the Architect, such defects may be repaired and at no additional cost to the Owner.
 - 1. Rock pockets, voids, spalls, cracks and exposed reinforcing shall be repaired with 1:2 cement mortar or cut out and patched. Prepare surfaces and bond cement mortar with concrete adhesive as hereinafter specified.
 - 2. Floor surfaces which exceed the allowable variation in plane or level (when an 8'-0" long straightedge is laid on the finished surface, the surface varies more than 3/16" in 8'-0") shall be ground and/or filled to obtain the level and plane required. Fill materials, where required, shall be of type approved by the Architect.
 - 3. Surfaces which are not plumb and square or which do not conform to the lines and levels indicated shall be chipped, ground, filled or trued as required to obtain the desired results.
- E. Uniformity of Concrete: All aggregates shall be measured by weight and the proportion of water to cement shall be accurately controlled by either automatic measuring devices or calibrated containers. All concrete placed shall be uniform strength and color appearance as well as surface texture.
- F. Screeds shall be provided all construction joints as required to ensure installation of concrete to lines and elevations noted.
- G. Ready-Mixed Concrete: ASTM C94 / C94M-09a except as otherwise specified herein.
- H. Tests: For structural concrete, the Testing Lab shall take four (4) test cylinders of concrete

each day for every 50 cubic yards of concrete or fraction thereof being placed. Cylinders shall be made and stored as per instructions given by the testing laboratory and shall be in accordance with ASTM Specifications C-31 / C31M-09 and C-39 / C39M-09a. Cylinders shall be tested for ultimate compressive strength of concrete with one cylinder tested at the age of 7 days and two (from the same batch) to be tested at the age of 28 days, with one cylinder held as a spare for future testing if needed. Tests shall be made by a recognized test laboratory selected by the Owner and approved by the Architect.

1. Cylinders not meeting the required design stresses shall indicate defective concrete and such concrete shall be removed and replaced at no increase in cost to the Owner. Core tests requested by the Contractor to establish design stresses, when cylinder tests indicate defective concrete, shall be paid for by the Contractor.

1.05 SUBMITTALS

- A. Submit under provisions of Section 00 33 00.
- B. Manufacturer's Data: Submit manufacturer's product data with application and installation instructions for proprietary materials and items, including reinforcement and forming accessories, admixtures, patching compounds, joint systems, chemical floor hardeners, and others as may be requested by the Architect.
- C. Shop Drawings: Shop drawings sheet size shall be 24" x 30" minimum.
 1. Reinforcing Steel: The correctness of the bending diagrams is the responsibility of the Contractor. Identify such shop drawings with a reference thereon to sheet and detail numbers from the contract drawings. No reinforcing steel shall be fabricated without approved shop drawings.
 2. Construction mount layout per paragraph 3.05.
- D. Concrete Mix Design: Submit proposed mix design prepared by concrete supplier. Mix design must be submitted to Owner for review and acceptance by a recognized independent testing lab, for all structural concrete.

1.06 JOB CONDITIONS

- A. Traffic Control: Maintain access for vehicular and pedestrian traffic as required by construction activities.

PART 2 – PRODUCTS

2.01 FORM MATERIALS

- A. Plywood Forms shall be exterior plyform, in large sheets of adequate thickness to support the imposed loads, but in no case less than 5/8" thick.
- B. Lumber Forms may be used for concrete surfaces that are unexposed and require no further surface applied materials. Lumber, if used, shall be clean and sound 2 x 12 No. 2 grade or better Douglas fir.
- C. Form Coating: Form shall be coated with nongrain-raising and nonstaining types of form coating that will not leave a residual matter on the face of the concrete or adversely affect proper bonding of any subsequent paint or other surface applications.

1. Form coating containing mineral oils or other nondrying materials will not be permitted for any concrete work.

2.02 REINFORCING MATERIALS

- A. Reinforcing Bars: ASTM A615 / A615M -09b with Supplement S1, marked "S", Grade 60 for #4 bar and larger, Grade 40 for bars smaller than #4.
- B. Furnish 6x6 W1.4xW1.4 welded wire fabric in flat sheets; rolls will not be allowed.
- C. Wire Ties for tying reinforcing steel shall be #16 annealed wire.
- D. Bar Supports: Comply with CRSI "Recommended Practice for Placing Bar Supports, Specifications and Nomenclature, Latest Edition", except as otherwise specified. Wood is not permitted as supports for reinforcing.
- E. Spacers and Chairs: As manufactured by Kalman Steel Company, Concrete Engineering Company, or approved equal.

2.03 CONCRETE MATERIALS

- A. Portland Cement: ASTM C150 / C150M-09, Type II, low alkali. All cement used shall be of one manufacturer.
 1. Use Type IIA cement if pumping of concrete is selected and permitted for placing of concrete.
 2. All cement shall contain not more than 0.6 percent total alkali when calculated as sodium oxide as determined by "Methods of Chemical Analysis of Hydraulic Cement", ASTM C114-09b.
- B. Water: Clean and free from deleterious amounts of acids, alkalis, salts and organic matter.
- C. Concrete Aggregates: ASTM C33 / C33M-08 except as otherwise specified hereinafter. All aggregates shall be nonreactive and nondegenerative, and shall consist of sound crushed rock, washed gravel, or a combination of both.
 1. Modify fine aggregates when air entrained concrete is used in accordance to Paragraph 4.2.4 of ASTM C33 / C33M-08.
 2. Aggregate sources shall be approved by the Architect. Aggregate shall result in shrinkage of concrete not exceeding .048 percent at 28 days. Testing lab shall verify aggregate and concrete shrinkage.
 3. Do not use fine or course aggregates that contain substances that are known to cause spalling or adverse reactions in the concrete.
- D. Air Entraining Agents shall be used in concrete at the contractor's option. The maximum entrained air content shall be no more than 4 percent + 1 percent by volume. Approved air entraining agents are Sika AER, Master Builders Micro Air, Darex AEA and Protex AEA.
- E. Admixtures: Except for air entraining agents and water-reducing admixtures, no other admixtures shall be used without written approval from the Architect. Where such agents are permitted, they shall be a type approved and used only as directed by the Architect and at no increase in cost to the Owner. Where water reducing admixtures are specified, they

shall be Master Builders Pozzoloth 322-N, used at the rate of 5+2 fluid ounces per 100 pounds of cement.

1. Calcium chloride will not be permitted for use in concrete under any circumstances.

2.04 CRUSHED ROCK BASE:

- A. Under all new concrete ramps and paving, or as otherwise indicated on the Drawings, provide a minimum of 4 inches of crushed rock fill. Crushed rock fill shall be clean gravel of 1" max. size and have no material passing through a No. 4 sieve.

2.05 JOINT MATERIAL:

- A. Provide 3/8" wide fiber expansion joint material, Model No. 320-F, as manufactured by W.R. Meadows or equal.
- B. Provide Snap-Cap as manufactured by W.R. Meadows or equal. Snap-Cap shall have a top plastic edge that can be used for leveling concrete. Once concrete has set up, top edge of Snap-Cap can be pulled free and discarded. Joint shall then be sealed.
- C. Joint sealing material shall be a two-component, self-leveling, polyurethane elastomeric sealant. Product shall be Sikaflex 2cSL as manufactured Sika Corporation, or equal. Color shall be chosen from the full range of manufacturer's standard colors.

2.06 RELATED MATERIALS

- A. Concrete Adhesive and Bonding Agent: "Concresive #1001-LPL" (1-1/2 hour maximum pot life), an epoxy polysulfide type concrete adhesive as manufactured by Master Builders or equal.
- B. Liquid Curing Compound: W.R. Meadows, Product: "Vocomp-20" or equal.
- C. Bonding Adhesive: Burke, Bondcrete-S; use as a modifier for patching and overlays up to 1/2" thick or equal.
- D. Doweling Epoxy: Burk Epoxy MV or equal.

2.07 CONCRETE DESIGN

- E. The concrete mix shall be proportioned to produce a minimum ultimate compressive strength at 28 days of 3,000 psi for structural concrete and 2,500 psi for all other concrete (section 02520) unless otherwise noted.
 1. Laboratory Mix Design: Concrete designs, per Section 1905.A.2 of the CBC, Title 24, shall be reviewed by the Testing Laboratory. The concrete mix designs reviewed by the Testing Laboratory and approved by the Project Architect or Structural Engineer shall be used by the Contractor. Contractor shall provide samples of aggregates as required by the laboratory to review the mix designs.
 2. Water Reducing Admixture: All concrete shall contain a water reducing admixture.
 3. Air Entraining Agent: Include in all concrete in all exterior concrete to result in concrete at point of placement having an air entrainment of 6% (+/- 1 1/2%).
 4. Maximum water - cement ratio at point of placement: .50.

- F. Ready-Mixed Concrete: ASTM C94 / C94M-09a except as otherwise specified herein.
1. Transit-mixed concrete shall be mixed for a period of not less than 10 minutes at a peripheral drum speed of approximately 200 feet per minute, and mixing shall be continued until discharge is complete. At least 3 minutes of the mixing period shall be at the job. Transit mixers shall be equipped with water measuring devices consisting of either accurately calibrated water tanks or water meters.
 2. When outside air temperature is between 85 degrees and 90 degrees, reduce mixing and delivery time from 90 minutes to 75 minutes. When outside air temperature is above 90 degrees, reduce mixing and delivery time to 60 minutes.
- G. Job Mixing: The capacity of the mixer shall be such that it will handle one or more full sack batches. No split sack batches will be permitted except when all materials are weighed. The rated capacity of the mixer shall not be exceeded. The mixing drum shall be equipped with an automatic timing and locking device and with an accurate water gauge for measuring the amount of water used. Mixing time of each batch shall be at least 1-1/2 minutes after all ingredients are in the mixer.
- H. Slump of Concrete: The slump of concrete as determined by the Standard Test Method for Slump of Hydraulic Cement Concrete ASTM Designation C-143 / C143M-09 shall be as follows:
1. All Concrete: 3 to 4 inches maximum.

PART 3 – EXECUTION

3.01 FORMS

- A. Build and Erect Forms to conform to the required shapes, patterns, lines, grades and dimensions indicated. Forms shall be substantial and tight to prevent any leakage of mortar, properly braced and tied together to maintain their position and shape. Forms shall not deflect under the dead load weight of the plastic concrete or construction loads. Joints in forming material shall be butted tightly and shall bear on solid construction. Provide tool edges where indicated. Completed form work to be checked for grade and alignment to tolerances not exceeding 1/8" in 10'-0" for top of forms and not more than 1/4" in 10'-0" for vertical face.
- B. Cast-in Items: Set in formwork all new sleeves, inserts, anchors, and similar items furnished and required under the work of other sections. Brace, anchor and support cast-in-items to prevent displacements and distortions.
- C. Clean forms after each use and coat with release agent as required.

3.02 REINFORCEMENT FABRICATION

- A. Steel reinforcement shall not be bent or straightened in a manner that will injure the material. Bars with kinks or bends not shown on the Drawings shall not be used. Heating of the bars for bending will not be permitted.
1. Spacers and chairs shall be as specified or detailed and spaced such that steel reinforcement will be carried without deflection.
 2. Concrete blocks may be used to support bottom layer of steel in floor slabs on grade.

3. Bars shall be in long lengths with laps and splices as shown. Offset laps 5'-0" in adjacent bars. Place steel with clearances and cover as shown. Bar laps shall be as indicated on the drawings. Tie all laps and all intersections with specified wire. Maintain clear space between parallel bars not less than 1-1/2 times nominal diameter for round bars, or twice side dimension for square bars, but in no case shall clear space be less than 1-1/2", nor less than 1-1/2 times maximum size concrete aggregate.
4. Reinforcing dowels for slabs shall be placed as detailed. Grease one penetration so that pour will not bond to dowel. Sleeves may be used if approved by the Architect before installation. Install dowels through all construction and expansion joints for all slabs on grade.
5. Install welded wire fabric in lengths as long as possible. Lap adjoining pieces at least one full mesh and lace splices with wire ties. Offset laps of adjoining widths to prevent continuous laps in either direction.
6. Cut bars true to length with ends square and free of burrs.

B. Drawing Notes: Refer to notes on Drawings for additional reinforcement requirements.

3.03 CONCRETE PLACEMENT

A. Surrounding Conditions: Before any concrete is placed, the following items of work shall have been completed in the area of placing.

1. Forms shall have been erected, adequately braced, cleaned, sealed, lubricated if required, and bulkheaded where placing is to stop.
 - a. Any wood forms other than plywood shall be thoroughly water soaked before placing any concrete. The wetting of forms shall be started at least 12 hours before concreting.
2. Reinforcing steel shall have been placed, tied, supported, and, at the time the concrete is placed around it, shall be cleaned of rust, scale, mill scale or other coatings that will destroy or reduce bond.
3. Embedded work of all trades shall be in place in the forms and adequately tied and braced.
4. The entire place of deposit shall have been cleaned of dirt, chips, sawdust, rubbish, debris, hardened concrete and other foreign matter before concrete is deposited therein. No wooden ties nor blocking shall be left in concrete except where indicated for attachment of other work.
5. Concrete surfaces to which fresh concrete is to be bonded shall be saw cut and broken away as indicated. Surfaces shall be brush cleaned to remove all dust and foreign matter and to expose the aggregate, and then coated with the bonding adhesive herein specified.

B. Conveying Concrete from mixer to forms shall be as rapid as possible.

1. Ready-mixed concrete shall be mixed and delivered in accordance with ASTM C94 / C94M-09a. A delivery ticket shall be furnished for each load of ready-mix or transit-mix concrete. A copy of each delivery ticket shall be handed to the job superintendent at the time of delivery and unloading. A record copy of the delivery

tickets shall be forwarded to the Architect for his files.

2. Conveying equipment shall be of a sufficient capacity to ensure a practically continuous flow of concrete to the placing point without separation or loss of materials. Carts and buggies shall be equipped with pneumatic tires. Runway supports shall not bear on reinforcing or fresh concrete. All conveying equipment shall be thoroughly cleaned before beginning and at frequent intervals during the placing of the concrete.
 - a. Chutes, if employed, shall slope not less than 4" or more than 6" per foot of horizontal run.
 3. Exercise care not to spill concrete on forms and reinforcing steel during the conveying operations. Where such spillage or splattering occurs, the surfaces shall be thoroughly cleaned before concrete hardens.
- C. Placing Concrete: Notify the Architect at least 48 hours in advance of beginning of pouring operations. Under no circumstances shall concrete that has partially hardened be deposited on the work. No concrete shall be placed during rainy weather without the Architect's approval.
1. Before starting new pour on or against concrete that has hardened, forms shall be retightened and the hardened concrete roughened and thoroughly cleaned of foreign matter and any laitance by sandblasting. Just ahead of the new pour, slush joints with a 2" layer of grout of the designated concrete mix minus 50 percent of the large aggregate.
 2. Reinforcing steel exposed to the sun shall be cooled by a water spray prior to the placing of concrete.
 3. No adjustment of steel reinforcement will be permitted during the placement of concrete.
 4. Concrete shall be scheduled so that the placing is a continuous operation for the completion of each section between predetermined construction joints. If a planned concreting operation cannot be carried on continuously, the concreting shall stop at temporary bulkheads. Locate where resulting construction joints shall be as shown on the Drawings or as approved by the Architect. Prior to placing of concrete for any concrete slabs, the moisture content of the subgrade below the slabs shall be adjusted to at least optimum moisture.
 5. Deposit the concrete in forms as nearly as practicable in its final position to avoid flowing and maintain until completion of the unit an approximate horizontal plastic surface. Thoroughly compact all concrete during placing operations, thoroughly around reinforcement, embedded fixtures or accessories, and into the corners of forms to eliminate air pockets and honeycombing. Compacting shall be done with mechanical vibrators. Vibrators shall not be used to cause concrete to flow horizontally. Thoroughly compact concrete to the forms to release the air and secure full contact of the concrete with the forms.
 6. Hot Weather Concreting: Concrete placing and finishing operations during hot weather shall be done as quickly as possible. Ample personnel shall be available to handle and place the concrete immediately after its mixing or delivery to the site of the work. Concrete shall be placed in layers thin enough and over areas small enough to ensure complete bond and union of adjacent layers, and thus prevent "cold joints".

- a. At air temperatures of 80 degrees Fahrenheit or above the following precautions should be taken:
 - 1) In no case shall the temperature of the concrete exceed 90 degrees Fahrenheit when placed in the work.
 - 2) If necessary to produce and maintain concrete at an acceptable temperature, chopped or crushed ice shall be added directly into the mixer up to 50 percent by weight of the mixing water used, the weight of the ice being included in batch weight of the mixing water. The ice shall be added at such a rate and in such a manner that it will be completely melted by the time concrete is mixed.
 - 3) Stockpiled aggregates shall be saturated and kept surface moist by continuous fog spray or by intermittent sprinkling.
 - 4) Forms, reinforcements and subgrade surfaces shall be wet down immediately before concrete is placed in contact therewith. Remove all excess water before placing concrete. Wetting down of areas around the work to cool the surrounding air and increase the humidity is recommended.
7. Cold Weather Requirements: Do not place concrete when ambient temperature is below 40 degrees Fahrenheit and falling.

3.04 CONCRETE FINISHING

- A. All Concrete Work, except as otherwise specified, shall be of a quality that will present a finished appearance upon the stripping of the forms. Only a minimum of patching and finishing should be necessary as required to fill holes left by form ties and to remove any fins or minor irregularities left by the joints in the forms. Except as otherwise specified, all concrete surfaces shall be finished as follows:
- B. Final Tooling: Tool edges of paving, gutters, curbs and joints formed in fresh concrete with a jointing tool to a radius of 1/4". Repeat tooling of edges and joints after applying surface finishes. Eliminate tools marks on all concrete surfaces.

3.05 CONSTRUCTION JOINTS

- A. Control joints shall be saw cut into concrete as soon as concrete slab can be walked on. Do not wait until the following day to saw cut concrete slab control joints.
- B. Construct contraction, construction, and isolation joints true to line with faces perpendicular to surface plane of concrete. Construct transverse joints at right angles to the centerline unless otherwise indicated.
- C. Joints at Existing Concrete: All joints between existing concrete and new concrete are to include dowels a t a minimum of #4 bars @ 4'-0" on center, 18" maximum from the ends, epoxy set into existing concrete a minimum of 6" in length at the centerline of existing concrete slab.
- D. Contraction Joints(Control Joints): Provide weakened-plane contraction joints, sectioning concrete into areas indicated. Construct contraction joints for a depth equal to at least 1/4 of the concrete thickness. Form in fresh concrete by grooving and finishing each edge of joint with a radiused jointer tool. Joints to be spaced at 10' on center maximum or as shown on

the drawings.

- E. Construction Joints: Set construction joints at side and end terminations of concrete placement and at locations where placement operations are stopped for more than 1/2 hour, unless placement ends at isolation joints.
1. Provide preformed galvanized steel or plastic keyway-section forms or bulkhead forms with keys. Use Burke "Keyed Kold Joint Header Form", or approved equal. Embed keys at least 1 1/2" into concrete.
 2. Continue reinforcement across construction joints.
 3. Use bonding agent on existing concrete surfaces that will be joined with fresh concrete.
- F. Isolation Joints(Expansion Joints): Form isolation joints of performed joint filler strips abutting concrete curbs, catch basin, manholes, inlets, structures, walks, other fixed objects, and where indicated.
1. Extend joint fillers full width and depth of joint, not less than 1/2" or more than 1" below finished surface where a joint sealant is indicated. Place top of removable joint filler flush with finished concrete surface.
 2. Protect top edge of joint filler during concrete placement with metal, plastic, or other temporary, removable performed cap.
 3. After concrete has set up, remove cap exposing top edge of fiber joint filler, and apply joint sealant.

3.06 PUMPING OF CONCRETE may be permitted for concrete, providing:

- A. The Contractor engages a testing laboratory to design concrete mixes for pumping. Trial batches shall be made and tested as required hereinbefore for typical concrete.
- B. The quality and proportioning of aggregates for pumping conditions shall be determined in accordance with ACI, Recommended Practice 613. Aggregate proportioning must be tailored to the particular pump intended for use.
- C. When starting a pump operation, actual pumping of concrete shall be preceded by a mortar mix (concrete without coarse aggregate) for the purpose of lubrication.
- D. All mortar and concrete leakage resulting from pumping operations shall be removed from formwork, reinforcing steel and any finished surface.

3.07 CURING

- A. Protect freshly placed concrete from premature drying and excessive cold or hot temperature. Comply with the recommendations of ACI 306R for cold weather protection and ACI 305R for hot weather protection during curing.
- B. Evaporation control is to be implemented in hot, dry and windy weather by protecting concrete from rapid moisture loss before and during finishing operations with an evaporation control material. Apply in accordance with manufacturer's instructions after screeding and bull floating, but not before floating.
- C. Begin curing after finishing concrete but not before free water has disappeared from

concrete surface.

- D. Cure concrete by moisture curing, moisture-retaining-cover curing, curing compound, or a combination.
 - 1. For moisture-curing, keep surfaces continuously moist for not less than 7 days with water, a continuous water-fog spray, or absorptive cover kept wet continuously wet.
 - 2. For moisture-retaining-cover, cover concrete with moisture retaining cover with side and end laps sealed.
 - 3. For curing compound, apply in accordance with manufacturer's instructions. Recoat areas subjected to rainfall within 3-hours after initial application.

3.08 CLEANING AND PROTECTION

- A. Clean all surfaces and leave in satisfactory condition to receive final finish surface treatment.
- B. Protect concrete surfaces from damage by tools, equipment, material and workmen. No traffic, shoring or other loading will be permitted until concrete has hardened sufficiently to prevent injury to finish and strength, but at least 14 days.
 - 1. Remove surface stains and spillage of materials as they occur.
 - 2. Sweep concrete and wash free of stains, discolorations, dirt, and other foreign material prior to final inspection.

[END OF SECTION 03 30 00]

**SECTION 05 40 00
COLD FORMED METAL FRAMING**

The General Conditions, Supplementary Conditions and Division 1 General Requirements are hereby made a part of this Section as fully as if repeated herein.

PART 1 – GENERAL

1.01 SECTION INCLUDES

- A. Load bearing formed steel stud exterior wall framing.

1.02 RELATED SECTIONS

- A. Section 00 70 00: General Conditions.
- B. Section 06 10 00: Rough Carpentry.
- C. Section 07 92 00: Joint Sealants.
- D. Section 09 21 16: Gypsum Board Assemblies.

1.03 REFERENCES

- A. ASTM A123 / A123M-09- Zinc (Hot-Dip Galvanized) Coatings on Iron and Steel Products.
- B. ASTM A924 / A924M-09a- General Requirements for Steel Sheet, Metallic-Coated by the Hot-Dip Process.
- C. AWS D1.1 - Structural Welding Code.
- D. AWS D1.3 - Structural Welding Code – Sheet Metal.
- E. SSPC (Steel Structures Painting Council) - Steel Structures Painting Manual.
- F. MFMA (Metal Framing Manufacturers Association) - Guidelines for the Use of Metal Framing.
- G. ASTM A653 - Standard Specification for Steel Sheet, Zinc-Coated (Galvanized) or Zinc-Iron Alloy-Coated (Galvannealed) by the Hot-Dip Process
- H. ASTM A1011 - Standard Specification for Steel, Sheet and Strip, Hot-Rolled, Carbon, Structural, High-Strength Low-Alloy, High-Strength Low-Alloy with Improved Formability, and Ultra-High Strength

1.04 SUBMITTALS

- A. Submit under provisions of Section 01 33 00.
- B. Shop Drawings: Indicate component details, framed openings, bearing, anchorage, loading, welds, type and location of fasteners, and accessories or items required of related work.
- C. Indicate stud layout.
- D. Describe method for securing studs to tracks and for welded framing connections.

- E. Product Data: Provide data on standard framing members; describe materials and finish, product criteria, and limitations.
- F. Manufacturer's Installation Instructions: Indicate special procedures and perimeter conditions requiring special attention.

1.04 QUALITY ASSURANCE

- A. Calculate structural properties of framing members in accordance with AWCI, MFMA, and AWS D1.3 requirements.

1.05 QUALIFICATIONS

- A. Manufacturer: Company specializing in manufacturing the Products specified in this section with minimum three years experience.
- B. Installer: Company specializing in performing the work of this section with minimum three years experience.

1.06 FIELD MEASUREMENTS

- A. Verify that field measurements are as indicated on shop drawings.

1.07 COORDINATION

- A. Coordinate work under provisions of Section 01 50 00.
- B. Coordinate with the placement of components within the stud framing system, specified in Divisions 15 and 16.

PART 2 – PRODUCTS

2.01 FRAMING MATERIALS

- A. Studs: ASTM A653 SS or A1011 SS , Grade 33 sheet steel for 43 mil or lighter gage, formed to channel shape, solid web, thickness and depth as indicated on drawings.
- B. Track: Formed steel; channel shaped; same width as studs, tight fit; same gage as studs, solid web. Provide deep leg track at "Slip-Track" deflection assembly.

2.02 ACCESSORIES

- A. Bracing, Furring, Bridging: Formed sheet steel, thickness determined for conditions encountered.
- B. Plates, Gussets, Clips: Formed sheet steel, thickness determined for conditions encountered.
- C. Touch-Up Primer for Galvanized Surfaces: SSPC - Paint 20 Type II Organic zinc rich.

2.03 FASTENERS

- A. Self-drilling, Self-tapping Screws, Bolts, Nuts and Washers: ASTM A123 / A123M-09, hot dip galvanized to 1.25 oz/sq ft.

- B. Welding: In conformance with AWS D1.1 and AWS D1.3.

2.04 FINISHES

- A. Studs: Galvanize to G90 coating class.
- B. Tracks and Headers: Galvanize to G90 coating class.
- C. Bracing, Furring, Bridging: ASTM A123 / A123M-09, hot dip galvanized to 1.25 oz/sq ft.
- D. Plates, Gussets, Clips: ASTM A123 / A123M-09, hot dip galvanized to 1.25 oz/sq ft.

PART 3 – EXECUTION

3.01 EXAMINATION

- A. Verify site conditions under provisions of Section 01 50 00.
- B. Verify that building framing components are ready to receive work.

3.02 ERECTION OF STUDDING

- A. Install components in accordance with manufacturer's instructions.
- B. Place studs at 16 inches oc(or as shown on drawings); not more than 2 inches from abutting walls and at each side of openings. Connect studs to tracks using method shown on drawings.
- C. Construct corners using minimum three studs. Double stud wall openings, door and window jambs.
- D. Erect load bearing studs one piece full length. Splicing of studs is not permitted.
- E. Erect load bearing studs, brace, and reinforce to develop full strength, to achieve design requirements.
- F. Install intermediate studs above and below openings to align with wall stud spacing.
- G. Provide deflection allowance in stud track, directly below horizontal building framing at non-load bearing framing.
- H. Attach furring channels to studs for attachment of fixtures anchored to walls.
- I. Install framing between studs for attachment of mechanical and electrical items, and to prevent stud rotation.
- J. Touch-up field welds and damaged galvanized surfaces with primer.
- K. Complete framing ready to receive exterior finish system.

3.03 ERECTION TOLERANCES

- A. Maximum Variation from True Position: 1/8 inch.
- B. Maximum Variation of any Member from Plane: 1/8 inch.

[END OF SECTION 05 40 00]

**SECTION 05 50 00
METAL FABRICATIONS**

The General Conditions, Supplementary Conditions and Division 1 General Requirements are hereby made a part of this Section as fully as if repeated herein.

PART 1 – GENERAL

1.01 SECTION INCLUDES

- A. Shop fabricated ferrous metal items, galvanized and prime painted.

1.02 RELATED SECTIONS

- A. Section 00 70 00: General Conditions.
- B. Section 03 30 00: Cast-in-Place Concrete.
- C. Section 07 71 23: Manufactured Gutters and Downspouts.
- D. Section 09 91 00: Painting.

1.03 REFERENCES

- A. ASTM A36 / A36M-08 - Carbon Structural Steel.
- B. ASTM A53 / A53M-07 - Pipe, Steel, Black and Hot-Dipped, Zinc-Coated Welded and Seamless.
- C. ASTM A123 / A123M-09 - Zinc (Hot-Dip Galvanized) Coatings on Iron and Steel Products.
- D. ASTM A283 / A283M-03 (2007) - Low and Intermediate Tensile Strength Carbon Steel Plates.
- E. ASTM A307-07b - Carbon Steel Bolts and Studs, 60,000 PSI Tensile Strength.
- F. ASTM A924 / A924M-09a- General requirements for Steel Sheet, Metallic-Coated by the Hot-Dip process.
- G. ASTM A501-07 - Hot-Formed Welded and Seamless Carbon Steel Structural Tubing.
- H. AWS A2.1 - Standard Welding Symbols.
- I. AWS D1.1 - Structural Welding Code.
- J. SSPC - Steel Structures Painting Council.
- K. CBC - California Building Code, 2010 Edition.

1.04 SUBMITTALS

- A. Submit under provisions of Section 00 33 00.
- B. Shop Drawings: Indicate profiles, sizes, connection attachments, reinforcing, anchorage,

size and type of fasteners, and accessories. Include erection drawings, elevations, and details where applicable. Provide specific submittal for all ramp and sloped walk guide rails, handrails, and guardrails prior to fabrication clearly showing spacing of rails and embed details.

- C. Indicate welded connections using standard AWS A2.1 welding symbols. Indicate net weld lengths.

1.05 QUALIFICATIONS

- A. Welders' Certificates: Submit under provisions of Section 01 33 00, certifying welders employed on the Work, verifying AWS qualification within the previous 12 months.

1.06 FIELD MEASUREMENTS

- A. Field verify all dimensions prior to fabrication.

PART 2 – PRODUCTS

2.01 MATERIALS

- A. General: All material that will be exposed must be smooth and free of surface blemishes including pitting, seam marks, roller marks, trade names and irregularities.
- B. Steel Sections: ASTM A36 / A36M-08.
- C. Steel Tubing: ASTM A500, Grade B.
- D. Pipe and Downspouts: ASTM A53 / A53M-07, Type E, Grade B.
- E. Plates: ASTM A36 / A36M-08.
- F. Bolts, Nuts, and Washers: ASTM A307-07b.
- G. Drilled-in Concrete Anchors: Hilti “Kwik Bolt TZ” (ICC Report No. ESR-1917), Ramset T3 (ICC Report No. ESR-1955), or accepted equal; stainless steel for all exterior work; testing required.
- H. Drilled-in Masonry Anchors: Hilti “Kwik Bolt 3” (ICC Report No. ESR-1385), Ramset T3 (ICC Report No. ESR-1955), or accepted equal; stainless steel for all exterior work; testing required.
- I. Welding Materials: AWS D1.1; type required for materials being welded.
- J. Shop and Touch-Up Primer: TNEMEC 10-99 - Red primer or Devoe DEVGUARD 4141.
- K. Touch-Up Primer for Galvanized Surfaces: Zinc rich type.
- L. Metal Framing Channels: Channel members shall be fabricated from structural grade steel conforming to ASTM A924-09a; P1000 as manufactured by Unistrut or approved equal. Finish shall be hot-dip galvanized coating.
- M. Pipe/Conduit Clamps: Punch-press made from hot-rolled, pickled and oiled steel plates, strip or coil and conform to ASTM A36 / A36M-08; P2600 as manufactured by Unistrut or approved substitute. Finish shall be hot-dip galvanized coating.

- N. Non-Shrink Grout: Euco-Dry Pack Grout, natural aggregate, high strength non-shrink. "Pac-It" - W.R. Meadows, or approved equal.
- O. Removable Post Insert Sleeves: For mounting new posts/rails in new concrete, Wagner Companies EZ SLEEVE or equal. (888)243-6914.

2.02 FABRICATION

A. Workmanship

1. Form exposed work true to line and level with accurate angles and surfaces and straight, sharp edges.
2. Ease exposed edges to a radius of approximately 1/32 inch, unless indicated otherwise.
3. Form bent-metal corners to the smallest radius possible without causing grain separation or otherwise impairing work.
4. Weld corners and seams continuously, complying with AWS recommendations. At exposed connections, grind exposed welds smooth and flush to match and blend with adjoining surfaces. Welds to be imperceptible in finished work.
5. Form exposed connections with hairline joints, flush and smooth, using concealed fasteners wherever possible.

B. Assemblies

1. Use materials of sizes and thickness indicted or required to produce strength and durability in finished product for use intended.
2. Work to dimensions indicated.
3. Fit and shop assemble in largest practical sections for delivery to site.
4. Cut, reinforce, drill and tap miscellaneous metal work as required to receive finished hardware and similar items.
5. Exposed mechanical fasteners: When application will not permit concealed fasteners, locate exposed fasteners in unobtrusive manner, consistent with design of component, except where specifically noted otherwise. Use Phillips flat-head countersunk screws or bolts for exposed fasteners.
6. Supply components required for anchorage of fabrications. Fabricate anchors and related components of same material and finish as fabrication, except where specifically noted otherwise.
7. Fabricate joints exposed to the weather to be weather tight and provide weep holes as required.

C. Fit and shop assemble in largest practical sections, for delivery to site.

D. Fabricate items with joints tightly fitted and secured.

E. Continuously seal joined members by continuous welds.

- F. Grind exposed joints flush and smooth with adjacent finish surface. Make exposed joints butt tight, flush, and hairline. Ease exposed edges to small uniform radius.
- G. Exposed Mechanical Fastenings: Flush countersunk screws or bolts; unobtrusively located; consistent with design of component, except where specifically noted otherwise.
- H. Supply components required for anchorage of fabrications. Fabricate anchors and related components of same material and finish as fabrication, except where specifically noted otherwise.

2.03 FINISHES

- A. Prepare surfaces to be primed in accordance with SSPC SP 2.
- B. Prime all surfaces that are not scheduled to receive galvanization, except, do not prime surfaces embedded in concrete nor in areas of field welds until welds are completed and inspected.
- C. Prime paint items with one coat.
- D. Galvanize in accordance with ASTM A123 / A123M-09, designated steel items. Provide minimum 1.25 oz/sq ft galvanized coating.

PART 3 – EXECUTION

3.01 EXAMINATION

- A. Verify that field conditions are acceptable and are ready to receive work.
- B. Beginning of installation means erector accepts existing conditions.
- C. Contractor shall conform all existing downspouts to remain are fully functional.

3.02 PREPARATION

- A. Clean and strip primed steel items to bare metal where site welding is required.
- B. Supply items required to be cast into concrete or embedded in masonry with setting templates, to appropriate sections.

3.03 INSTALLATION

- A. Install items plumb and level, accurately fitted, free from distortion or defects.
- B. Allow for erection loads, and for sufficient temporary bracing to maintain true alignment until completion of erection and installation of permanent attachments.
- C. Field weld components indicated on shop drawings.
- D. Perform field welding in accordance with AWS D1.1.
- E. Obtain Architect approval prior to site cutting or making adjustments not scheduled.
- F. After erection, prime welds, abrasions, and surfaces not shop primed, except surfaces to be in contact with concrete.

3.04 SCHEDULE

- A. The Schedule is a list of principal items only. Refer to Drawing details for items not specifically scheduled.
1. Steel pipe railing, (galvanized at exterior, primed at interior).
 2. Pipe rail wall support brackets, (galvanized at exterior, primed at interior).
 3. Steel pipe downspouts and downspout support brackets, galvanized.
 4. Unistrut P-1000 Support System.

[END OF SECTION 05 50 00]

**SECTION 06 10 00
ROUGH CARPENTRY**

The General Conditions, Supplementary Conditions and Division 1 General Requirements are hereby made a part of this Section as fully as if repeated herein.

PART 1 – GENERAL

1.01 SECTION INCLUDES

- A. Description of requirements for materials, fabrications and installation of rough carpentry and associated items (except that which is specified elsewhere) indicated on Drawings and necessary to complete the work. Items include, but are not necessarily limited to, the following:
 - 1. Blocking, Backing, Stripping, Furring, and Nailers.
 - 2. Rough Hardware.
 - 3. Wood Framing.
 - 4. Plywood Sheathing.
 - 5. Preservative Treatment.
 - 6. Metal Fabrications.

1.02 RELATED SECTIONS

- A. Section 00 70 00: General Conditions
- B. Section 03 30 00: Cast-in-Place Concrete
- C. Section 06 20 00: Finish Carpentry
- D. Section 07 90 00: Joint Protection

1.03 QUALITY ASSURANCE

- A. Manufacturer data: Submit product data for all materials specified under this section and as applicable to each site.
- B. Coordinate the work of all trades to ensure proper placement of all materials, anchors, etc., as well as providing for openings and anchors for the installation of surface mounted materials and equipment.
- C. Qualifications of Workmen: Provide sufficient skilled workmen and supervisors who shall be present at all times during execution of this portion of the work and who shall be thoroughly familiar with the type of construction involved and the materials and techniques specified.
- D. Rejection: In the acceptance or rejection of rough carpentry, no allowance will be made for lack of skill on the part of the workmen.
- E. Requirements of Regulatory Agencies:

1. California Building Code Standard, No. 23-1, "Classification, Definition and Methods in California of Grading all Species of Lumber":
 - a. No. 23-2 - "Construction and Industrial Plywood".
 2. California Building Code (CBC), edition applicable to project per cover sheet.
- F. References and Standards: Provide materials graded under latest Edition of the pertinent following Agencies:
1. American Society for Testing and Materials (ASTM).
 2. Lumber: West Coast Lumber Inspection Bureau (WCLIB), Rule 17, Standard Grading Rules for West Coast Lumber.
 3. Lumber: Western Wood Products Association (WWPA); Western Lumber Grading Rules.
 4. Plywood: American Plywood Association (APA) Plywood Specifications and Grades and Voluntary Product Standard DOC PS 1 "Construction and Industrial Plywood".
 5. Wood Preservative: American Wood Protection Association (AWPA), Standard U1.
 6. California Building Code, latest edition.
- G. Design Criteria: Pressure treatment shall not adversely affect application, permanence, or appearance of finish paint system.

1.04 SUBMITTALS

- A. Submit under provisions of Section 01 33 00.
- B. Certification:
 1. Pressure Treated Wood: Certification for water-borne preservative that moisture content was reduced to 19% maximum, after treatment.
 2. Pressure Treated Wood: Submit certification by treating plant stating the chemicals and process used, net amount of salts retained, and conformance with applicable standards.

1.05 PRODUCT DELIVERY, STORAGE AND HANDLING

- A. Protection, General: Protect wood from moisture while being stored and while work is in progress.
- B. Protection:
 1. After delivery, store all materials in such a manner as to ensure proper ventilation and drainage and to protect against damage and the weather.
 2. Keep all material clearly identified with all grade marks legible; keep all damaged material clearly identified as damaged, and separately store to prevent its

inadvertent use. Do not allow installation of damaged or otherwise non-complying material.

3. Use all means necessary to protect the installed work and materials of all other trades.

- C. Replacements: In the event of damage, immediately make all repairs and replacements necessary to the approval of the Architect and at no additional cost to the Owner.

1.06 JOB CONDITIONS

- A. Environmental Requirements: Maintain uniform moisture content of lumber at 19 percent or less prior to close-in.
- B. Sequencing: Coordinate details with other work supporting, adjoining, or fastening to rough carpentry work.

PART 2 – PRODUCTS

2.01 MATERIALS

- A. Wood:

1. Lumber (Blocking, Backing, Stripping, Furring, and Nailers): WCLIB Construction.
2. Lumber (Wood Framing): Meet requirements of following minimum grades:

Item	Species	Grade	Reference
Studs	D.F.	No. 1 2 x 4 Light Framing	WCLIB 124b
Studs	D.F.	No. 1	WCLIB 121
Plates	D.F.	No. 1	WCLIB 123b
Beams	D.F.	Select Structural	WCLIB 130b
Joists	D.F.	No. 1	WCLIB 123b
Posts	D.F.	Select Structural	WCLIB 131b

3. 3X and larger lumber shall be free of heart center.
4. 2x6 T & G Douglas Fir No. 1.

- B. Plywood:

1. Roof and Wall Structural Sheathing: PS-1 Structural 1, CDX APA with exterior glue.
2. Thickness and type shall be as indicated on Drawings.

- C. Pressure-Treated Lumber:

1. Douglas Fir pressure-treated.
 - a. Required for cast-in-nailers, sills or anywhere wood is in contact with concrete, masonry or grout.
 - b. Required for all rooftop blocking.

- D. Building Paper: Fed. Spec. UU-B-790a, Type I, Grade B (15 lb. min.).

E. Preservative Treatment

1. Furnish pressure treated Douglas Fir in accordance with AWPA, Standard U1. Each piece is required to bear AWPA stamp.
2. Field treat cut edges and holes drilled in factory treated lumber with an approved AWPA Standard U1 preservative product.
3. For fastener requirements, see Paragraph 2.01-F-8.

F. Rough Hardware Fastenings and Connections: All types including bolts, lag screws, nails, spikes, screws, washers, framing devices and other rough hardware, or kinds that may be purchased and that require no further fabrication, shall be furnished and installed for all finish and rough carpentry. All exterior hardware shall be hot-dipped galvanized per ASTM A123 / A123M-09 Standards.

1. Nails:
 - a. ASTM F1667 Common wire nails or spikes; box nails not permitted.
2. Bolts: ASTM A307-07b, Grade A, hexagonal heads, unless noted otherwise.
3. Washers: Washers for bearing against wood shall be provided under all bolt heads and nuts. Washers shall be as indicated on Drawings.
4. Powder Driven Fasteners: Tempered steel pins with special corrosive-resistant plating or coating. Pins shall have guide washers to accurately control penetration, minimum 1-1/8 inch. Fastening shall be accomplished by low-velocity pistol-driven powder activated tool. Pins and tool shall be as manufactured by Hilti Fastening Systems; Impex Tool Corporation; or approved equal. ICBO approved.
5. Fabricated Sheet Metal Timber Framing Connectors: CBC approved. Fabricate from hot-dipped galvanized steel. Connectors shall be at least 18 gauge minimum material (1/8" plate materials where welded, unless otherwise noted), punched for nailing. Nails and Nailing shall conform to the manufacturer's instructions with a nail provided for each punched hole. Types as noted on Drawings, manufactured by Simpson Co. or approved substitute. All framing connectors shall be stamped with manufacturer's logo, and model designation.
6. Lag Screws: Conform to ASTM A307-07b. Dimensions and installation shall conform to requirements described in the National Design Specification (NDS), 1991 edition.
7. All fasteners into preservative-treated and fire-retardant-treated wood shall be of hot dipped zinc-coated galvanized steel, stainless steel, silicon bronze or copper. The coating weights for zinc-coated fasteners shall be in accordance with ASTM A 153. Fasteners other than nails, timber rivets, wood screws and lag screws shall be permitted to be of zinc coated steel with coating weights in accordance with ASTM B 695, Class 55 minimum.

G. Exterior Trim and Fascias: RIS Grade Stamped, Redwood, B Heart, Vertical Grain, Kiln Dried, surfaced sizes as indicated on the drawings.

2.02 FABRICATION

- A. Lumber:
 - 1. Air- or kiln-dry to maximum 19 percent moisture content, prior to installation. Lumber must be 19 percent moisture content prior to close-in and finish.
 - 2. Furnish S4S unless otherwise noted.
 - 3. Size to conform with rules of governing standard. Sizes shown are nominal unless otherwise noted.

2.03 SOURCE QUALITY CONTROL

- A. Grade Mark each piece of lumber. Marking must be done by recognized agency. Lumber Manufacturer's Association Certificates may be accepted in lieu of such grade and trademarks.
 - 1. Douglas Fir shall bear WCLIB grade stamp.
- B. Plywood Sheathing: Each panel shall be legibly identified as to type, grade and specie by APA grade. If plies are spliced, the slope of the scarf shall not be steeper than 1:8. White pockets will not be permitted in face plies.
- C. Each piece of preservative treated lumber shall bear AWPA stamp.

2.04 WOOD PRESERVATIVE TREATMENT

- A. Preservative treatment: Comply with applicable requirements of AWPA standards C2 for lumber and C9 for plywood. After treatment, kiln dry lumber to a maximum moisture content of 19 percent, and plywood to 15 percent.
 - 1. Pressure treat members connected with roofing, flashing and weatherproofing; including but not limited to cants, nailers, curbs, equipment supports and blocking.
 - 2. Pressure treat members that are concealed and in contact with masonry or concrete, including, but not limited to, sills, nailers, blocking, furring and studs.

PART 3 – EXECUTION

3.01 SURFACE CONDITIONS

- A. Inspection:
 - 1. Prior to all work of this Section, carefully inspect the installed work of all other trades and verify that all such work is complete to the point where this installation may properly proceed.
 - 2. Verify that rough carpentry may be performed in strict accordance with the original design and all pertinent codes and regulations.
- B. Selection of Lumber Pieces: Carefully select all members. Select individual pieces so that knot and obvious defects will not interfere with placing bolts or proper nailing or making proper connections. Cut out and discard all defects which will render a piece unable to serve its intended function.

- C. Lumber may be rejected by the Architect, whether or not it has been installed, for excessive warp, twist, bow, crook, mildew, fungus, or mold, as well as for improper cutting and fitting. No load carrying member shall be exposed to earthen materials.
- D. Shimming: Do not shim any framing component.

3.02 FASTENING

- A. Nailing: Except as otherwise indicated on Drawings or specified, all nailing shall be as scheduled on Drawings:
 - 1. Nails or Spikes shall be common wire unless noted otherwise. Penetration of nails or spikes shall be one-half the length of the nail or spike into the piece receiving the point. However, to connect pieces 2 inches in thickness, 16d nails shall be used unless noted otherwise.
 - a. Bore holes for nails wherever necessary to prevent splitting.
 - b. Use finish or casing nails for finish work.
 - c. Use of nailing guns is as limited by CBC, and must be approved by Architect and DSA. Submittal of guns and nails is required.
- B. Bolts: Bolts shall be of sizes indicated. Drive fit with washers under nuts. Tighten all bolts and screws before closing in.
- C. Framing Devices: As specified under Products, sizes as indicated. Use half-length nails where required.
- D. Lag Screws: Pre-Bore lead holes and install per CBC Chapter 23.

3.03 FRAMING AND ROUGH CARPENTRY

- A. Sills: Shall be in long lengths of sizes shown, fastened with anchor bolts at exterior walls and with powder driven fasteners at interior walls as indicated, a minimum of two (2) fasteners per piece and a bolt within 9" but not nearer than 6" from end of piece. Place malleable iron or steel plate washers (but not cut washers) under nuts bearing on wood. Set sills level and true and bed exterior wall sills and interior bearing wall sills on 1/2 inch dry-pack or non-shrink grout.
- B. Studs, Posts and Columns: Shall be full length. Corners shall be as detailed. Partitions or walls containing plumbing, heating or other piping shall be so formed as to give proper clearance for materials. Cut members as required to provide full bearing at ends. Connect to structure as indicated.
- C. Plates: Shall be in long lengths and spliced as shown.
- D. Blocking: Shall be same thickness and width of studs or joists unless shown otherwise. Blocking shall not be spaced over 8'-0" o.c. Install fire blocking in accordance with CBC, Section 717. Install blocking at all plywood joints unless otherwise noted on the drawings. Install blocking for fastening all surface applied items.
- E. Joists and Beams: Shall be in long lengths and spliced over bearings unless shown otherwise. Install with crown side up. Beams or headers indicated to be built up of two or more joists shall be fabricated on the job using full length members. For two piece

members, stitch nail pieces together with 16d common nails spaced not over 12" o.c. and staggered. Clinch nails protruding through members.

1. Provide double joists and headers at all openings through floors and roofs unless otherwise shown on Drawings.
 2. Provide typical headers at all openings through walls where one or more studs are required to be cut. For penetration through walls narrower than stud spacing, provide solid backing on all sides for fastening finish materials.
- F. Plywood Structural Sheathing: Install to pattern indicated and provide blocking at joints where noted on the drawings. Center all joints over bearing supports. Nail to framing as indicated. Install plywood with face plies perpendicular to joists or studs unless indicated otherwise.
- G. Wood Furring, Stripping and Grounds: Install as shown or required to provide nailing of materials or passage of pipes, conduits, etc., not otherwise accommodated.
- H. Bridging: Space not over 8'-0" o.c. for spans over 16'-0". Spans over 8'-0" and under 16'-0" shall have bridging placed at midspan. Bridging shall be two 2 x 3's or solid blocking as indicated. Joists 8" or less in depth shall not require bridging unless specifically indicated.
- I. Backing: Shall be provided for all wall and ceiling finishes and for supporting of fixtures and equipment for all trades, including toilet partitions, toilet room accessories, frames, case work, mirrors, trim, applied wall finishes, etc. Coordinate placement of backing and supports with manufacturer or supplier of mounted items.
- J. Building Paper: Install two layers in all exterior locations. Install with weather lap edges a minimum of 2 inch horizontal and 6 inch vertical laps. Continue building paper minimum 6 inches around inside and outside corners. Fasten in place with appropriate staples.
- K. Cuts or holes in preservative treated wood shall be treated in accordance with AWPB standard M4 in the field.

3.04 MISCELLANEOUS HARDWARE

- A. Finish hardware is specified in Section 08 71 00. All other hardware indicated or required but not specified elsewhere shall be furnished and installed hereunder, including appropriate screws or other fastening devices.

3.05 MISCELLANEOUS CARPENTRY WORK

- A. Miscellaneous Carpentry Work not included under other sections shall be furnished and installed hereunder as indicated. Carefully locate and securely anchor such items to structure.
- B. Drypack: Drypack shall consist of 1 part high early strength Portland cement to not more than 3 parts of sand by volume. Add only a minimum amount of water to hold the mixture in shape while packing and to provide hydration. Solidly ram drypack into place to provide uniform bearing and cure with moist sacks or cloths for a period of at least three (3) days.
- C. Plywood Backing for electrical, telephone, and similar types of wall mounted equipment shall be provided hereunder where required. Plywood shall be 3/4" thick exterior A-C plywood with 'A' face exposed.

- D. Shoring and Bracing: Shore or brace for temporary support of all work as required during the construction period except any shoring and bracing specified and included under other sections of these specifications.
- E. Temporary Enclosures: Provide and maintain all barricades and enclosures required to protect the work in progress.
- F. Protect all work in progress and all work installed, as well as the work of all other trades. Any work damaged as a result of the work under this section shall be corrected to its original condition or replaced if directed by the Architect and at no increase in cost to the Owner.
- G. Protection Devices: Pedestrian walkways, barricades, lights, shoring and other protective structures and devices necessary for the protection of pedestrians shall conform in all respects to the requirements of CBC, Section 3303, Title 24 and to the requirements of the Department of Public Works.

3.06 FRAMING TOLERANCES

- A. Maximum variation from true flatness: 1/4 inch in ten feet in any direction.

3.07 CLEAN-UP

- A. Upon completion of the work of this Section, remove all surplus materials, rubbish and debris from the premises.

[END OF SECTION 06 10 00]

**SECTION 06 20 00
FINISH CARPENTRY**

PART 1 – GENERAL

1.01 SECTION INCLUDES

- A. Finish Carpentry Items and Trims, Other Than Shop Fabricated Casework.
- B. Miscellaneous Hardware and Attachment Accessories.

1.02 RELATED SECTIONS

- A. Section 00 70 00: General Conditions.
- B. Section 06 10 00: Rough Carpentry.
- C. Section 09 90 00: Painting and Coatings.
- D. Section 08 71 00: Door Hardware.
- E. Section 09 92 16: Vinyl Coated Fabric Wall Panels.

1.03 QUALITY ASSURANCE

- A. Standards of Construction: All work shall be manufactured in accordance with WIC-MM (latest edition) including all supplements and in the grades hereinafter specified.
- B. Installer's Qualifications: Use only journeymen finish carpenters who are thoroughly trained and experienced in the skills required for the cutting and fitting of trim and finish materials.
- C. Installation Acceptance: All rejected work shall be removed and replaced with no additional cost to the Owner.

1.04 SUBMITTALS

- A. Submit under provisions of Section 01 33 00.
- B. Shop Drawings: Shop drawings shall include details and erection data associated with the work of other trades; location; materials, species of wood; quality grade; type of finish; profiles, dimensions; fastenings and clearances. Detail drawings shall be either full size or three inches equals one foot (3" = 1').
 - 1. The mill shall take and be responsible for all field measurements required for the proper fabrication and installation of the work. Show all field dimensions beyond control of mill.
 - a. Report any major discrepancy between the Drawings and the field dimensions to the Architect before fabrication of the work.
 - 2. Coordinate dimensions and installation requirements of Owner furnished equipment.
- C. Samples: Submit samples of all interior and exterior trims and moldings materials.

1.05 PRODUCT DELIVERY, STORAGE AND HANDLING

- A. Delivery: Do not deliver material to site until required temperature and relative humidity conditions have been stabilized and will be maintained in installation areas.
- B. Storage, Handling and Protection: Provide all work or materials necessary to store, cover and protect all materials specified to be furnished and installed under this Section. Store all materials under cover in a well-ventilated enclosure and protect against extreme changes in temperature and humidity. Avoid any marring and keep the materials clean during handling and installation operations. Protect exposed finish work and materials after their erection from damage of any character. Work damaged through neglect or failure to provide protection shall be repaired or replaced by the Contractor without additional cost to the Owner.

PART 2 – PRODUCTS

2.01 MATERIALS

- A. All Material Grades and Construction shall be WIC custom grade, including all supplements, unless specified or indicated otherwise. Semi-exposed and other components shall be as permitted by WIC standards for construction quality specified herein except as otherwise detailed or specified. Moisture content shall be in accordance with WIC Standards for millwork.
- B. Wood Trim/Molding: Douglas Fir, surfaced, Kiln Dried, Opaque Finish.
- C. Adhesives:
 - 1. For Exterior Work: CS 35-61 Type I (fully waterproof). Shall withstand shear and cyclic boil tests specified in PS 51-71.
 - 2. For Interior Work: CS 35-61 Type II (water-resistant). Shall withstand cold-soak tests specified in PS 51-71.
- D. Fasteners:
 - 1. Bright finish nails for interior work; aluminum or galvanized nails for exterior work. Screws shall be cadmium plated.
 - 2. Lag Screws: Conform to ASTM A307.
- E. Wood Door/Window Frames: Douglas Fir, vertical grain, surfaced, kiln dried opaque finish.

2.02 FABRICATION, GENERAL

- A. Moisture Content for all finish carpentry shall lay between 6 and 12 percent, consistent with the average atmospheric conditions at the project.
- B. Scribing Allowance: Provide at walls, ceilings, etc., in accordance with WIC standards.
- C. Surfaces: Machine sanded on all flat top face areas, smoothly machine run in all depressed flat surfaces and on molded contours. Sander marks shall be fine enough to be completely concealed by the painter's applied finish work. All members shall be finished true and straight, with all edges clean cut and all exposed surfaces free from all working defects.

- D. Lengths shall be those usually available in the species specified.
- E. Milling: All finish carpentry and millwork members shall be milled to dimensions and profiles indicated. Provide surface applied or plowed stops of the profile and dimension shown. Except where exact lengths can be determined, all members and materials shall be provided "long" for cutting and fitting in the field. Built-up members shall be fabricated as detailed and shall be carefully assembled to provide a finished product that is free from warp and defects and is true to line.
 - 1. Assemble in the mill in as large units as practicable to minimize field cutting and fitting. Where necessary to fit at the site, provide ample allowance for cutting and fitting.

PART 3 – EXECUTION

3.01 CONDITION OF SURFACES

- A. Examine all framing, grounds, stripping and blocking to secure finish carpentry and trim. Do not install finish carpentry and trim until all defects are corrected.

3.02 INSTALLATION

- A. Workmanship Quality: All wood finish shall be installed level, plumb and true, with members neatly and accurately scribed in place. All trim shall be applied in lengths as long as practicable. Butt joints shall be beveled together, exterior angles mitered and interior angles coped, unless shown otherwise. All exposed nails and screws shall be set for putty unless indicated or specified otherwise.
- B. Wood Trim: Set plumb and square. Verify wall thickness for proper trim width. Anchor trim securely to structure to prevent rotation or damage. All wood trim installed in the field shall be carefully cut to length and all joints neatly made to provide for tight, rigid connections.

3.03 MISCELLANEOUS

- A. Provide and install all miscellaneous finish carpentry items to conform to the workmanship quality specified above and shown on the Drawings. Millwork shall be installed in a neat, workmanlike manner, free of hammer marks and surface defects. Pieces shall fit together neatly with all corners mitered. Do not install finish carpentry until it has been backprimed as specified in Painting Section 09 91 00.

3.04 CLEAN-UP

- A. General: Keep the premises in a neat, safe and orderly condition at all times during execution of this portion of the work, free of accumulations of sawdust, cut-ends and debris.
- B. Clean-up: Upon completion of the work of this Section, remove all surplus materials, rubbish and debris from the premises and leave "broom clean".

END OF SECTION

**SECTION 06 41 16
PLASTIC-LAMINATE-CLAD ARCHITECT CABINETS**

PART 1 – GENERAL

1.01 SECTION INCLUDES

- A. Special fabricated cabinet units.
- B. Countertops (plastic laminate and epoxy resin).
- C. Cabinet hardware.
- D. Resin sinks and setting materials.
- E. Preparation for installing utilities.
- F. Removal, modification and reinstallation of selected existing casework.

1.02 RELATED SECTIONS

- A. Section 00 70 00: General Conditions.
- B. Section 06 20 00: Finish Carpentry.
- C. Section 09 65 00: Resilient Flooring/Base.
- D. Section 09 90 00: Painting (refinishing of cabinets for reuse).
- E. Division 22: For resin and stainless steel sinks, faucets, trims and other related new and existing mechanical work.
- F. Division 26: For new and existing electrical work installed in casework.

1.03 REFERENCES

- A. ANSI/BHMA A156.9 - Cabinet Hardware.
- B. WI - Woodwork Institute, Architectural Woodwork Standards, latest edition.
- C. FS MM-L--736 - Lumber, Hardware.
- D. National Electric Manufacturers Association (NEMA) LD3 - High Pressure Decorative Laminates.
- E. PS 20 - American Softwood Lumber Standard.

1.04 SUBMITTALS

- A. Submit under provisions of Section 01 33 00.
- B. Shop Drawings:

1. Must bear WI certificate of compliance stamp and be in accordance with Section 1 of the AWS Manual.
 2. Indicate materials, component profiles and elevations, assembly methods, joint details, anchorage details, accessory listings, hardware schedule, and schedule of finishes.
 3. Submit plan, section, elevation and perspective drawings necessary to describe and convey layout, profiles, and product components, including edge conditions, joints, fitting and fixture locations, anchorage, accessories, and finish colors.
 4. The casework fabricator shall take and be responsible for all field measurements required for the proper fabrication and installation of the work. Show all field dimensions beyond control of mill.
 - a. Report any major discrepancy between the Drawings and field dimensions to the Architect before fabrication of the work.
 5. Indicate conditions for all casework, identified with locations, quality grade, type of finish and species of wood.
 6. Show casework in related and dimensional position with sections either full size or three inches equals 1 foot (3" = 1').
 7. Coordinate dimensions of equipment or items indicated to be built into the casework.
 8. Coordinate dimensions and installation of Owner-furnished equipment.
 9. Indicate casework hardware proposed for use.
- C. Product Data: Manufacture literature for all hardware to be provided.
- D. Samples:
1. Finishes for color, pattern and texture selections.
 2. Hardware: drawer pulls, drawer slides, hinges, locks and other hardware accessories.
- E. Samples: Submit two physical samples and product data sheets of drawer pulls, drawer slides, hinges, locks, and other specified hardware accessories, illustrating hardware type and finish.

1.05 QUALITY ASSURANCE

- A. This project requires WI Certification for product and installation.
- B. All work shall be manufactured and installed in accordance with the standard established in the latest edition of the Manual of Millwork (including any amendments) as adopted by the WOODWORK INSTITUTE (WI) in Custom Grade.
- C. All casework to bear WI stamp of certification per elevation.
- D. All casework construction and installation shall be inspected and accepted by WI.

- E. Mockup:
 - 1. Mockup shall include a complete free-standing laboratory instructor's demonstration table.
 - 2. Include base cabinet, epoxy resin countertop/sink and all trim and accessories.
 - 3. Locate where directed during pre-con meeting.
 - 4. Approved mockup may remain as part of the Work.

1.06 QUALIFICATIONS

- A. Manufacturer: WI certified company specializing in manufacturing the products specified in this section with minimum five years experience.

1.07 PRE-INSTALLATION CONFERENCE

- A. Convene one week prior to commencing installation work of this section.

1.08 DELIVERY, STORAGE, AND HANDLING

- A. Protect units from moisture damage, and deter their erection from damage of any character. Work damages through neglect or failure to provide protection shall be made good by the contractor and without additional cost to the Owner.

1.09 FIELD MEASUREMENTS

- A. Verify that field measurements are as shown on shop drawings and are coordinated with actual field conditions.
- B. Field verify existing finish floor conditions to insure specified finish countertop heights and knee space clearances at accessible stations are maintained. If shimming is required to level units, this shall be taken into account in base cabinet construction.

1.10 COORDINATION

- A. Coordinate the work with electrical rough-in, to assure orderly and efficient sequence of installation of interdependent construction elements, with provisions for accommodating items installed later.

PART 2 – PRODUCTS

2.01 SHEET MATERIALS

- A. Engineered Core Plywood: Veneer core inner plies layered with MDF cross bands, 3/4 inch thick equal to ClassicCore by Columbia Forest Products. Provide face material compatible with laminate finishes listed below. All casework components shall use Engineered Core Plywood unless otherwise indicated in this Section.
- B. Melamine Faced Industrial Board: At all concealed and some "semi-exposed" locations provide low pressure thermoset melamine over industrial grade 3/4" engineered core plywood. Facing color to be selected by Architect from manufacturer's full range of standard color.

1. Interiors of closed cabinets may be melamine faced.
 2. Interiors of drawers may be melamine faced.
- C. High Pressure Decorative Laminate (HPDL – Plastic Laminate): At all exposed surfaces and some “semi-exposed” locations provide high pressure plastic laminate, minimum 0.048-inch thick as manufactured by Wilsonart, Formica, Nevamar, or approved equal. Colors to be selected from manufacturer’s full range of colors in Matt finish.
1. Open shelving units, shelves and cabinets with glass doors and open cubbies to be plastic laminate. Melamine finish will not be accepted at these locations.
- D. Plywood Sub-top: At all new cabinet locations provide ½” thick AC structural plywood as shown on drawings. Edge bind all exposed edges to match cabinet body. Provide longer ‘leg’ as shown on drawings to attach to wall ledger.
- E. Fasteners: Bolts, Nuts, Washers, Lags, Pins, and Screws to be per WI standards and as shown on approved shop drawings.

2.02 COUNTERTOPS

- A. Countertops to have integral splashes.
- B. Countertops, splashes and ends shall be faced with High-Pressure Laminated Plastic Sheets, a minimum of .050 inches thick. Underside of countertops shall have a backing sheet applied.
- C. All countertops with sinks or adjacent to sinks are to have no drip edge.

2.03 LABORATORY EPOXY RESIN LABORATORY TOPS & SPLASHES

- A. Sheets cast from modified epoxy resin and non-asbestos inert fillers; compounded mixture cured and thermoset specifically from formulation to provide exceptional physical and chemical resistance required in medium to heavy duty laboratory environments. Product shall be equal to that as manufactured by Durcon Incorporated, 512-595-8000.
- B. Thickness: 1 inch. Maximum variation in thickness: plus or minus 1/16 inch from corner to corner.
- C. Color shall be Black Onyx
- D. Sheets monolithic throughout without surface coating application.
- E. Physical properties; minimum acceptable physical performance in accordance with SEFA 3 testing procedures:
 1. Density/specific gravity: Tested to ASTM D792; minimum test rating of 134.8 PSF.
 2. Rockwell hardness: Tested to ASTM D785; minimum M scale rating of 110.
 3. Fire resistance: tested to ASTM D635; classified as self-extinguishing.
 4. Surface burning characteristics: Tested to ASTM E84; flame spread index 7.4 and smoke develop index of 221.2.
 5. Surface burning characteristics in vertical position: Tested to ASTM D3801; maximum flame spread index of 7.4 and smoke developed index of 221.2.

6. Coefficient of linear thermal expansion: Tested to ASTM D696; rating of 2.46×10^{-5} .
7. Heat deflection: Tested to ASTM D648; maximum 205 degrees F.
8. Flexural strength: Tested to ASTM D790; minimum rating 14.9 KPSI.
9. Flexural modulus: Tested to ASTM D790; 2,777,501 PSI.
10. Water absorption, 24 hours: tested to ASTM D570; maximum 0.008 percent by weight.
11. Compression strength: Tested to ASTM D695; minimum 38.4 kpsi.
12. Chemical resistance; minimum acceptable chemical resistance performance in accordance with SEFA 8.

2.04 LABORATORY EPOXY RESIN LABORATORY SINKS

- A. Sheets cast from modified epoxy resin and non-asbestos inert fillers; compounded mixture cured and thermoset specifically from formulation to provide exceptional physical and chemical resistance required in medium to heavy duty laboratory environments and equal to those as manufactured by Durcon Incorporated, 512-595-8000.
- B. Epoxy sink sizes for the following rooms: S1, S1A, S3, S5, S5A, S7, S9, S9A, S10.
 1. Sink No. D03C - All student peninsula countertops.
 2. Sink No. A25 - All teacher demonstration tables, all student accessible sink locations.
 3. Sink No. A55 - All prep rooms.

2.05 HARDWARE

- A. Hardware shall be furnished and installed as required to provide for a complete casework installation. Provide all additional hardware items as needed for a complete and proper installation as recommended by WI Supplemental No. 1 for Finish Hardware.
- B. Hardware shall be 626 finish, unless specified otherwise.
- C. Drawer and Cabinet Locks:
 1. Provide where indicated on the drawings at new and/or existing drawers and doors.
 - a. Where indicated to match existing and tie into existing keying system; locks to be heavy-duty type, with cylinder type(s) and be capable of using existing key(s). Contractor shall be responsible for reviewing existing locks and keys to best identify new lock compatibility.
 - b. Where indicated to tie into new keying system; all casework locks to be Schlage CL-1000 Series with high security Primus cores.
 2. Provide for individual keying of each lock. Provide (2) keys for each lock, plus (4) room master keys and (4) grand master keys. Keying schedule shall be provided by Owner during submittal review.
- D. Cabinet Hinges:
 1. Heavy-duty 5-knuckel hinges, 2 3/4" with 26D satin chromium plated finish as manufactured by; Stanley 1592 or Stanley 351490HT, or approved equal.
- E. Door and Drawer Pulls:

1. "U" shape, Stanley 4484, Hafele 116-05-922, or approved equal.
2. Brushed Chrome or Brushed Stainless Steel Finish

F. Drawer Guides:

1. Small Drawer (up to 12"): Accuride Model 2023 (50 lbs.)
Clear Zinc Finish
2. Medium Drawer (up to 24"): Accuride Model 7432(100 lbs.)
Clear Zinc Finish
3. Large Drawer (up to 36"): Accuride Model 4032: (150 lbs.)
Clear Zinc Finish
4. Extra Large Drawers (over 36") Accuride Model 3641: (180 lbs.)
Clear Zinc Finish

G. Magnetic Catches:

1. Epco 591, Jaybee 3776, or approved equal.
2. Floating or self-aligning type, aluminum or durable plastic case, type as required for conditions.
3. One per leaf for doors up to 48 inches high and two per leaf for doors over 48 inches.
4. Catch on inside of door to be mounted directly behind door pull on outside of door.

H. Elbow Catches:

1. Ives 2F14, National Lock B238, or approved equal. One at each pair of locked doors, omit magnetic catch.

I. Adjustable Shelf Supports with Seismic Retention Clips:

1. Shelf support rail, Hettich "Bodentragerschiene" #52116 or approved equal.
2. Shelf support clip, Hettich "Bodentrager" #52117 or approved equal.

J. Apparatus Rod Holders: Aluminum Burette Rod Socket, Chicago Faucets Model No. 9913-NF, or equal. Coordinate with epoxy resin tops and at location indicated on the drawings.

2.06 GLASS

- A. Where glass is identified in cabinet doors, glass shall be 1/4" thick clear tempered. Provide recessed frame reveal to receive glass for inset installation on interior of cabinet door. Secure with removable screw-type fasteners. Provide sealant or gaskets as required to securely fasten glass for tight fit without vibration.

2.07 REPAIRS TO EXISTING CASEWORK

- A. Where existing casework is identified for repair or components are being replaced, fabricate appropriate components to best suite replacement or repair work being performed and to best match existing construction materials, methods and finishes.
- B. All upper cabinets indicated to be reinstalled at new locations shall be refinished. Door pulls and locks shall be replaced (existing hinges to remain). Remove and replace pulls and locks with those specified herein. Only visible exterior surfaces need to be refinished. Interior areas behind glass and/or solid doors and shelving shall be cleaned and polished. See Section 09 91 00 Painting, for additional preparation and refinishing requirements. Where cabinets are required to be shortened, provide clean and smooth cuts at panel module. Sand all newly exposed surface smooth, fill any holes left by shelf brackets and stain/finish bare wood to match balance of refinished cabinet exterior.

2.08 FABRICATION

- A. Construction Style:
 - 1. 3/4 inch thick; flush overlay Style "1", Type A construction, Custom Grade, WI certified casework.
 - 2. Apply high pressure plastic laminate finish in full, uninterrupted sheets consistent with manufactured sizes.
 - 3. Fit corners and joints hairline; secure joints with concealed fasteners. Slightly bevel arises.
 - 4. Locate counter butt joints minimum 2 feet from sink cut-outs.
- B. Edging:
 - 1. Front edge of shelves to have one-piece 1 mm PVC edge banding.
 - 2. Case edges to have one-piece 1mm PVC edge banding.
 - 3. Colors to be selected from manufacture's full range of standard colors.
 - 4. Edge band all four sides.
- C. Shelving:
 - 1. All shelving less than 25" to be 3/4 inch thick melamine covered engineered core plywood.
 - 2. All shelves between 25" to 34" to be 1" inch thick melamine covered engineered core plywood.
 - 3. All shelves between 34" to 46" to be 1" inch thick HPL covered engineered core plywood.
 - 4. All shelves over 46" to be 1" inch thick HPL covered engineered core plywood.
 - 5. Fixed shelves shall be dadoed into vertical.

6. Dividers, where used as vertical supports, shall be 3/4" melamine covered engineered core plywood with 1" PVC edging.
 7. All shelves shall have holes on bottom front sides to receive adjustable shelf bracket seismic retention pins.
 8. Provide plexi-glass seismic lips as detailed on the Drawings and only at locations indicated on the Drawings.
- D. Countertops:
1. All countertops shall be fully supported as described in AWS, Section 11.
 2. Joints in countertops shall be layed out such that they do not occur at an open knee space or other open base cabinet area.
 3. Where open base conditions do occur, a front and rear apron shall be provided (if shown on the Drawings or not) and shall be constructed of plastic laminate covered base cabinet material in a depth as required to maintain a minimum 29" clearance to floor for accessibility access. Where accessible clearances may be tight, a painted steel angle or tube shall be provided as shown and detailed on Drawings.
- E. Laboratory Countertops, splashes and ends identified to be solid chemical/heat resistant epoxy resin as defined in section 2.03 above. All exposed edges shall have a minimum 1/8 chamfer. Countertop joints shall be layed out such that they do not occur at open knee spaces. Provide installation of epoxy resin products in full conformance with manufacturer's written instructions. Provide all sealants, adhesives, clamps and accessories for a complete installation.
1. Thickness:
 - a. 1 inch unless otherwise indicated.
 - b. Check each sheet at factory for required thickness.
 - c. Maximum variation in thickness: plus or minus 1/16 inch from corner to corner.
 2. Warpage:
 - a. Inspect tops for warpage prior to fabrication by placing on true flat surface.
 - b. Maximum allowable warpage: 1/16 inch in 36 inch span or 3/16 inch in 96 inch span.
 3. Fabrication:
 - a. Shop fabricate in longest practical lengths.
 - b. Bond joints with highly chemical resistant cement with properties and color similar to base material.
 - c. Provide extended nosing applied to underside of exposed front edge to adequately cover the plywood sub-top.
 - d. Provide 1/8 inch drip groove at underside of exposed edges, set back 1/2 inch from face.
 - e. Finish exposed edges.
 4. Fabricate tops flat at epoxy sink location.

5. Edge treatment: Standard 1/8 inch chamfered edge.
6. Corner treatment: exposed corners shall be eased slightly for safety.
7. Back and end splashes in dimensions and configurations as detailed on Drawings:
 - a. Supplied loose for field installation.
 - b. Same material and thickness as worksurfaces.
 - c. 6 inches high unless otherwise indicated.
 - d. Top-mounted end splash where worksurfaces abut adjacent construction at and locations indicated on Drawings.
8. Joints: Maximum 1/8 inch, bonded with epoxy grout.
9. Make joints between two benches level.
10. Locate joints away from sinks and over or near supports.
11. Sink cutouts: Routed for drop-in sink.
12. Allowable tolerances:
 - a. Square: Plus or minus 1/64 inch for each 12 inches of length.
 - b. Location of cutouts and drilled openings: Plus or minus 1/8 inch of design dimension.
 - c. Size of cutouts and drilled openings: Plus 1/8 inch or minus 0 inches.

F. Laboratory Epoxy Resin Sinks:

1. Mold sinks from thermosetting epoxy resin.
2. Mold interior corners to radius. Slope sink base to drain outlet.
3. Provide 1-1/2 inch outlet with open ended standpipe; standpipe overflow 2 inches shorter than depth of sink.
4. Unless otherwise indicated, fabricate sinks of drop-in design supported by upper flange from worksurface and continuously sealed per manufacturer's written installation instructions
5. Color: To match adjacent worksurface.
6. Provide all support bracing as required to adequately support sink per manufacturer's written instructions.

G. Glass in cabinet doors shall be securely fastened and fit tight without rattling in its setting bed. Provide glass inset in door per AWS Type B with removable interior stop.

H. Where existing casework is identified to be repaired, materials, methods and finishes shall best match existing to suite conditions of repair.

2.09 MISCELLANEOUS METAL ITEMS

- A. Provide as required to fabricate casework.
- B. Provide all other miscellaneous casework, counters, shelving, which are not otherwise specified. All such work shall be of custom grade quality with finishes as shown. Where no finish is indicated, it shall be same as similar or adjacent work.
- C. Clean all adjacent areas affected by casework installation.

PART 3 – EXECUTION

3.01 EXAMINATION

- A. Verify adequacy of backing and support framing.

6.02 INSTALLATION

- A. Set and secure casework in place; rigid, plumb, and level, in accordance with WI standards and DSA approved anchorage details.
- B. All fasteners securing cabinet bodies to preservative treated wood sill plates shall be of hot dipped zinc-coated galvanized steel, stainless steel, silicon bronze or copper. The coating weights for zinc-coated fasteners shall be in accordance with ASTM A 153.
- C. Use fixture attachments in concealed locations for wall mounted components.
- D. Use concealed joint fasteners to align and secure adjoining cabinet units counter tops and support brackets.
- E. Carefully scribe casework abutting other components, with maximum gaps of 1/32 inch. Do not use additional overlay trim for this purpose.
- F. Provide closure panels and seal all cases to walls including tops wall hung cabinets and tall cabinets.
- G. Countersink anchorage devices at exposed locations. Conceal with solid wood plugs of species to match surrounding wood; finish flush with surrounding surfaces.
- H. Where existing casework is identified for repair or components are being replaced, fabricate appropriate components to best suite replacement or repair work being performed. Where a cabinet unit may be removed and a free end left exposed, new end panels and filler strips shall be provided for a clean finish.
- I. Where new countertops are replacing existing, remove and re-install any and all apparatus support sleeves and other accessories. Re-install all electrical outlets, gas valves, water valves and other accessories unless otherwise noted.
- J. Field verify existing finish floor conditions to insure specified finish countertop heights and knee space clearances at accessible stations are maintained. If shimming is required to level units, this shall be taken into account in base cabinet construction. In no case shall specified finish countertop heights and clearances be compromised.
- K. When necessary to cut and fit on site, provide materials with ample allowance for cutting. Provide trim for scribing and site cutting.
- L. Provide cutouts for plumbing fixtures, apparatus sleeves, inserts, grommets, outlet boxes, fixtures and fittings. Verify locations of cutouts from on-site dimensions. Seal contact surfaces of cut edges. Where existing countertops are being replaced with new, remove and reinstall all existing fittings unless otherwise indicated on the Drawings.
- M. Install resilient wall base at all exposed toe-kicks and extend inside all accessible sink base cabinets.

3.03 ADJUSTING

- A. Adjust work prior to final inspection for smooth operation.
- B. Adjust moving or operating parts to function smoothly and correctly.
- C. Owner reserves the right to request an inspection by WI representative for conformance to reference standards.

3.04 CLEANING

- A. Clean work prior to final inspection.
- B. Clean casework, counters, shelves, hardware, fittings and fixtures.
- C. Clean all adjacent areas affected by Casework installation.

3.05 CONTRACTOR INSPECTION OF EXISTING CASEWORK

- A. Contractor shall review all hardware and operation condition of existing casework and notify Architect of any repair or replacement required to provide operation as if new.

END OF SECTION

**SECTION 06 83 16
FIBERGLASS REINFORCED PANELING**

PART 1 – GENERAL

1.01 SECTION INCLUDES

- A. Fiberglass Reinforced Plastic Panels.
- B. Accessories.

1.02 RELATED SECTIONS

- A. Section 00 70 00: General Conditions.
- B. Section 09 21 16: Gypsum Board Assemblies.

PART 2 – PRODUCTS

2.01 MATERIALS

- A. Fiberglass Reinforced Plastic Panels (FRP): Equal to Marlite FR Class 1A, or approved equal. 4 foot sheet width, .090 inch gauge. Flame spread <25, smoke generation <450, Class 1A. Pebble Surface, Color as selected by Architect from manufacturer's full range of standard colors.
- B. Accessories and Adhesives: Manufacturer's standard adhesive, and joinery trim system which hides each vertical joint and exposed edges.

PART 3 – EXECUTION

3.01 PREPARATION

- A. All surfaces to receive FRP shall be properly prepared in strict accordance with manufacturer's specifications and as specified herein. Fill all pin holes, cracks, and other surface imperfections with spackle and scrape off surface splatters and imperfections to leave substrate surfaces smooth and free of damage.
- B. All other trade work that penetrates substrate shall be completed before beginning FRP application.

3.02 APPLICATION

- A. FRP shall be installed with adhesive supplied by or recommended by the FRP manufacturer.
- B. Apply FRP panels according to manufacturer's instructions. No horizontal seams will be permitted.
- C. Install trim in longest practical lengths. "Piecing" of trim will not be allowed.
- D. Remove excessive adhesive from surfaces immediately.
- E. Ensure positive contact of FRP to adhesive material with all wall surfaces. Remove or replace damaged or improperly applied FRP.

- F. Provide continuous bead of caulk around all penetrations and transitions to adjacent materials.

3.03 CLEAN-UP

- A. Upon completion of the work of this Section, remove all surplus material, and debris from the premises.

END OF SECTION

07 21 00
THERMAL INSULATION

PART 1 – GENERAL

1.01 APPLICABLE REQUIREMENTS

- A. The requirements of Divisions 0 & 1 apply to all work of this Section.

1.02 SCOPE

- A. Building insulation required for this work includes, but is not necessarily limited to:
1. Thermal Insulation in walls and below roof deck.
 2. Sound Insulation.
 3. At fire rated assemblies, provide insulation at fire rated construction only as allowed by the California Building Code.

1.03 RELATED WORK SPECIFIED ELSEWHERE

- A. Section 06 10 00: Rough Carpentry

1.04 STANDARDS:

- A. CBC, California Building Code - 2010 Edition, as amended.
- B. California Quality Standards for Insulating Materials.
- C. CBC, Title 24, Chapter 2-53.
- D. CBC, Section 719, Latest Edition.

1.05 SUBMITTALS:

- A. Submit the following items in accordance with Divisions 0 & 1:
1. List of materials.
 2. Product data for each type of insulation specified.
 3. Insulation Certificate: Installer shall submit a copy to the Architect and post in a conspicuous location in each building a certificate signed by the installer and the General Contractor stating that the installation conforms with the requirements of CBC, Title 24, Chapter 2–53, and that the materials installed conform with the requirements of the California Quality Standards for Insulating Materials. The certificate shall state the manufacturer's name and material identification and the installed "R" value. Submittal required.

1.06 DELIVERY, STORAGE AND HANDLING:

- A. Deliver materials to the job site and store in a safe dry place with all labels intact and legible at time of installation.
- B. Protect building insulation materials before installation and protect the installed work and materials of other trades.
- C. In the event of damage, immediately make all repairs and replacements necessary to the approval of the Architect and at no additional cost to the Owner.

PART 2 – PRODUCTS

2.01 ACCEPTABLE MANUFACTURERS:

- A. Owens–Corning Fiberglass Corporation
- B. Celotex Corporation
- C. Johns-Manville.
- D. CertainTeed Corporation.
- E. USG Thermafiber (at fire rated construction assemblies where required by listed Design Number).
- F. Approved equal.

2.02 MATERIALS:

- A. Type A, Sound Insulation: A batt-like non-combustible, formaldehyde free product manufactured from inorganic fibers for installation in framed wall cavities. The nominal 16 inch, or as required x 96 inch batts shall be un-faced and sized to fit full depth of framed walls.
 - 1. Un-faced insulation shall comply with ASTM C-665, Type I. Provide fire rated type insulation at all rated walls to receive insulation.
 - 2. Product Fire Hazard Classification Rating as required by the specified codes and standards for use at locations and conditions indicated.
 - 3. Minimum Thickness: As required to fill full depth of wall cavity.
 - 4. Minimum R Value: 11.0 at 75 degrees F in accordance with ASTM C-518 and C-653.
 - 5. Flame Spread = 10, Smoke Developed = 10.
 - 6. Use at ALL interior framed walls (new and infill of existing locations) to full height and width of wall cavity or infilled opening.
- B. Type B, Friction-Fit Thermal Insulation: A blanket-like non-fire rated yet non-combustible, formaldehyde free product manufactured from inorganic glass fibers for installation in framed exterior walls. The nominal 16 inch, or as required wide blankets shall be faced with a factory applied integral kraft vapor barrier for use at protected spaces and code approved for exposed applications.

1. Faced insulation shall comply with ASTM C-665, Type II, Class C.
2. Composite Product Fire Hazard Classification Rating as required by the specified codes and standards for use at locations and conditions as indicated.
3. Minimum Thickness: As required to fill full depth of wall cavity.
4. Minimum R Value: 19 at 75 degrees F. at 6" or greater walls as shown on Drawings in accordance with ASTM C-518 or C-653.
5. Water Vapor Transmission (permeance): 1.0 perms maximum when tested in accordance with ASTM B-96, desiccant method. Moisture absorption less than 1% by volume.
6. Use at all non-rated exterior wall infill locations to full size of infilled opening.

2.03 MISCELLANEOUS MATERIALS:

- A. All other materials, such as additional insulation materials, fasteners, line wire, tape and retainers, not specifically described but required for a complete and proper installation of building insulation, shall be subject to submittal approvals.
 1. Provide additional insulation materials selected from manufacturer's standard materials. These materials shall conform to the specified Codes, Standards and performance requirements as indicated in the Contract Documents or as required for the complete and proper construction of the building envelope.

PART 3 – EXECUTION

3.01 INSPECTION:

- A. Prior to all work of this Section, carefully inspect and verify that the installed work of all other trades is complete to the point where this installation may begin.
- B. In the event of discrepancy, immediately notify the Architect. Do not proceed with installation in discrepant areas until all such discrepancies have been fully resolved.

3.02 INSTALLATION:

- A. Batt, Blanket Insulation: Provide insulation barrier system with no voids in system. Keep end joints to a minimum. Install with vapor barrier to warm (interior) side. Fit ends and edges tight to framing members. Keep all piping and other work on warm side of insulation. Provide tape vapor barrier joints. Tape as required.
- B. Install fire rated insulation where indicated on the Drawings or where required to maintain the code required integrity of fire-rated assemblies.

3.03 PROTECTION:

- A. Protect installed insulation from damage until covered.

END OF SECTION

SECTION 07 26 00
VAPOR RETARDERS
(Unit Cost Item)

PART 1 – GENERAL

1.01 SECTION INCLUDES

- A. Concrete Vapor Emission Control System for remediation of excessive slab moisture and / or alkyd levels.
- B. Repairs and preparation of concrete substrate and to install the concrete vapor emission control system.
- C. Subfloor testing after concrete treatment.

1.02 RELATED SECTIONS

- A. Bid Form: Bid Allowance with Unit Cost for potential slab treatment.
- B. Section 00 70 00: General Conditions.
- C. Exhibit C: Abatement of Hazardous Materials.
- D. Section 03 30 00: Cast-in-Place Concrete.
- E. Section 06 10 00: Rough Carpentry.
- F. Section 09 65 00: Resilient Flooring.

1.03 REFERENCES

- A. ASTM C920-08 – Elastomeric Joint Sealants.
- B. ASTM E96 / E96M-05 – Test Method for Water Vapor Transmission of Materials.
- C. ASTM F710-08
- D. ASTM F 1869 - Standard Test Method for Measuring Moisture Vapor Emission Rate of Concrete Subfloor Using Anhydrous Calcium Chloride
- E. ASTM F 2170 - Standard Test Method for Determining Relative Humidity in Concrete Floor Slabs Using in situ Probes

QUALITY ASSURANCE

- A. Manufacturer Qualifications:
 - 1. Ten-year experience in producing moisture vapor control emission products.
 - 2. Minimum \$5-million product liability insurance policy from an A-rated carrier.

3. A warranty program covering coats associated with repair or replacement of concrete vapor emission control system and finish floor covering or coating, including repair or replacement labor.
- B. Installer Qualifications:
1. Installer shall have experience in the installation of floor covering or floor coatings and shall have experience in the installation of concrete vapor emission control systems.
 2. Floor covering installer must be factory trained and certified for the installation of the specific products being installed.
 3. Installer to provide project inspector proof of certification prior to starting work.
 4. Certified installer must be present on job site while work is in progress.
- C. Testing Laboratory Qualifications:
1. Certified, bonded, qualified and experienced agency to perform pH and moisture vapor emission tests.
- D. Pre-installation Meeting:
1. Contactor to notify Construction Manager with a minimum of 5-days notice when anticipated to be ready for pre-installation meeting.
 2. Contractor, installer and manufacturer representative are required to attend pre-installation meeting. Contractor is responsible for coordinating and scheduling their attendance.
 3. Construction Manager will schedule meeting with Contractor team, Project Inspector, and Architect.
 4. Purpose of Meeting: To review subfloor condition and test results; determination of appropriate treatment system(s) and location(s); and review installation requirements.

1.05 SUBMITTALS

- A. Provide a complete submittal package with all components required within this section. Submit per Section 00700.
1. Product Data: Provide product data describing physical and performance characteristics, material safety data sheets, certificates, warranty information and manufacture's installation instructions for proposed product.
 2. Submit product manufacturer's field reports and test reports with warranty certification.
 3. Submit anhydrous calcium chloride testing according to ASTM F 1869-98 and RH Probe Tests results according to ASTM F 2170. Submit substrate pH readings. Tests shall be performed by the Owner's Inspector and results provided to the Architect,

Owner, General Contractor, flooring installer and Water Vapor Reduction System
Manufacturer's Representative.

1.06 DELIVERY, STORAGE AND HANDLING

- A. Delivery: Deliver materials in manufacturer's original, unopened, undamaged containers with identification labels intact.
- B. Store products in an approved ventilated dry area; protect from dampness, freezing, and direct sun light. Product should not be stored in areas with temperatures in excess of 90 °F or below 50 °F.

1.07 ENVIRONMENTAL REQUIREMENTS

- A. Areas to receive Vapor Emission Control System shall be clean, fully enclosed, weather tight with the permanent HVAC set at a uniform temperature per manufacturer's recommendation.
- B. Maintain ambient temperature required by manufacturer three days prior to, during, and 24 hours after installation of Vapor Emission Control System.
- C. Do not apply moisture vapor reduction system to unprotected surfaces or when water is accumulated on the surface of the concrete.
- D. Do not apply water vapor reduction system when temperature is lower than 50° F or expected to fall below this temperature within 24 hours from time of application.
- E. Protection: Protect water vapor reduction system to prevent damage from topical water for a minimum period of 24 hours from time of application.

1.09 WARRANTY

- A. Contractor shall file a pre-installation checklist with the manufacturer (as required) and receive written confirmation of the approval to proceed in order to obtain full warranty.
- B. Emission control system warranty must be from the manufacturer, in writing, and cover the cost of system materials, cementitious compounds and labor costs of application and preparation. In addition the warranty must extend to the flooring material, adhesive and installation labor.
- C. Warranty period shall be no less than ten years or the life of the flooring covering which ever comes first.
- D. Warranty exclusion shall be limited to:
 - 1. Moisture failure due to topical intrusion of plumbing failure or other substances entering from the surfaces.
 - 2. Seismic damage occurring after installation.
 - 3. Replacement of flooring during warranty period as removal of flooring could damage emission control system.

4. Aggregate found to be defective (expansive and reactive aggregate are examples).
- E. Warranty shall not exclude cracks visible at time of installation nor "improper installation".
- F. Manufacturer to provide evidence of a product liability insurance policy. Insurer shall have no less than an "A" rating from one of the four major rating services. A certificate of insurance shall be delivered to the Owner and shall name the Owner, Architect and General contractor as co-insured. Liability shall be in the amount of \$5-million per occurrence.

PART 2 – PRODUCTS

2.01 MATERIALS

- A. Vapor Emission Control System: The appropriate system(s) shall depend on the existing slab moisture and pH levels and the requirements of the specific floor covering product. The determination of which of the following systems would be most appropriate and the extent of treatment area(s) shall be made by the Owner's representative once the existing slab testing results are known.
 1. Koester VAP1 2000 System. 100% solids epoxy.
 2. Mapei Planiseal VS System. An alkali-resistant, two-component, 100%-solids epoxy coating that effectively stops moisture-related problems with floor coverings.
 3. ARDEX MC™ PLUS. 100% solids epoxy system.

2.02 MIX DESIGNS

- A. VAP1 2000:
 1. Use clean containers and mix thoroughly as per Manufacturer's requirements to obtain a homogeneous mixture. Use a low speed motor less than 400 rpm and a two bladed Jiffy mixing blade only. DO NOT AERATE. Mix ratios are measured by volume.
 2. VAP I® 2000 Mix Ratio: Mix Component A and B at a ratio of 2.4:1 by volume.
- B. Mapei Planiseal VS:
 1. Premix Part A to a homogenous consistency (2 to 3 minutes) using a low-speed mixer (at 300 to 450 rpm) and a "jiffy" (paint mixer) mixing paddle.
 2. Pour Part B into Part A container and mix thoroughly to a smooth, homogenous consistency. Do not mix at high speeds, which can trap air within the mixed material.
 3. Pour and spread the entire unit of any mixed Planiseal VS onto the substrate within 5 minutes of mixing.
- C. ARDEX MC PLUS:
 1. Each individual unit of ARDEX MC PLUS™ Red and ARDEX MC PLUS™ Green

contains separate, pre-measured quantities of the hardener (Part A) and the resin (Part B). The hardening agent (Part A) is added to the resin (Part B).

2. ARDEX MRP and/or ARDEX K 301 are mixed in 2-bag batches at one time. Mix each bag of powder with the prescribed amount of water using an ARDEX Mixing Paddle and a 1/2" heavy-duty drill (min. 650 rpm). Mix thoroughly for approximately 2-3 minutes to obtain a lump-free mixture. Follow written installation instructions for each material.
3. For mix designs related to the use of ARDEX underlayment and toppings, refer to the standard mixing instructions for installation over concrete as shown in the manufacturer's installation instructions.
4. For instructions on the filling of dormant cracks and joints, follow the written instructions of the selected epoxy manufacturer.

PART 3 – EXECUTION

3.01 EXAMINATION

A. Calcium Chloride, RH Probe and pH test requirements:

1. Anhydrous calcium chloride testing shall be performed by the Owner's Inspector.
2. Provide anhydrous calcium chloride tests according ASTM F 1869 – 08 protocol.
3. Provide RH Probe Tests according to ASTM F 2170 protocol.
4. Only conduct calcium chloride tests at the same temperature and humidity expected during normal use. If this is not possible then follow the F 1869 method for non acclimated spaces. Maintain these conditions 48 hours prior to and during tests. Water vapor transmission levels are directly affected by ambient room temperature and readings conducted without a sustained ambient temperature and humidity are NOT acceptable.
5. Provide substrate surface pH readings.
6. Owner's Inspector shall provide test results with a marked up floor finish plan showing test results. Inspector shall provide a written clarification on status of the ambient air temperature and humidity before and during the testing procedures.

B. Concrete Slab Inspection

1. Existing concrete slabs - Testing for concrete deficiencies and contaminants such as un-reacted silicates, chlorides, A.S.R. (alkali-silica reaction), oil contamination, etc. is recommended by Koster to avoid bonding issues. These conditions can cause bonding concerns with all epoxy and finished floor coatings, including the Koster VAP 1 2000. This testing is not required by Koster. This testing should be performed by the owner's independent testing agency using utilizing standard coring methods and review of the history of the slab installation if available. Concrete should conform to ACI Committee 201 Report "Guide to Durable Concrete."

2. New concrete slabs - Review Section 03300 curing compounds. Silicate based curing compounds should be avoided.

3.02 PREPARATION

- A. Inspect all surfaces with regard to their suitability to receive moisture vapor reduction system with manufacturer's representative.
- B. Clean all surfaces to receive moisture vapor reduction system. Shot blast all floors to a CPS #3 or #4 and clean surfaces with vacuum and remove all residue off the concrete. Grinding is allowed only in areas not accessible by shot blasting. Do not acid etch. Remove ALL defective materials, and foreign matter such as dust, adhesives, gypsum based patching and leveling compounds, paint, dirt, un-reacted sprayed on silicates, floor hardeners, bond breakers, oil, grease, curing agents, form release agents, efflorescence, laitance, shot blast bee bees, etc. Repair all cracks, expansion joint, control joints, and open surface honeycombs and fill in accordance with Manufacturers recommendations. Inform vapor reduction system manufacturer if concrete additives like silicates or chlorides or any other soluble compounds that have been used in the concrete mix or topically applied. Reinforcing fibers that are visible after shot blasting must be removed and vacuumed leaving no fibers left on the concrete surfaces. Provide uncontaminated, sound surface.
- C. Repair concrete prior to moisture vapor reduction system. Consult with vapor reduction manufacturer to determine suitable products for concrete repair.
- D. Shot blast a small test area and review surface profile with the finished flooring applicator. As the moisture vapor reduction system is not a leveling material make sure the flooring installer is aware that a feather finish or leveling material may be utilized to "flatten" the concrete after the application of the moisture vapor reduction system and prior to the flooring installation.
- E. Clean substrate surfaces to receive system treatment and treat surface irregularities with a 100% Portland Cement based patching compounded and cementitious fill compatible with prescribed system treatment as recommended by the manufacturer of the moisture control system.
- F. At all treated locations under finish goods i.e. carpet, VCT, etc., install self-leveling material to provide a smooth and uninterrupted concrete substrate for proper installation of floor finish.

3.03 JOINT AND CRACK PREPARATION

- A. VAP1 2000:
 1. Fill cracks, control joints, voids and deteriorated concrete with CTS Cements Rapid Set Cement All, Mortar Mix, Concrete Mix or Skim Coat prior to the VAP I 2000 application. Allow the products to cure according to Rapid Set's requirements before applying the VAP products over the repaired area. Do not use gypsum based cementitious patching, leveling and repair mortars under the VAP I 2000 systems. Cracks should be opened up to at least 1/4" x 1/4" to allow for a proper amount of Rapid Set materials to fill the voids. Any cracks/voids that may be contaminated by known or unknown substances should be routed out to remove any contaminants.
 2. Expansion joints should be repaired per the detail on the VAP I 2000 data sheets. A fumed silica epoxy thickening agent (Aerosil or Cabosil) can be added to the VAP I

2000 products and used in place of cementitious materials for control joints and cracks if needed.

3. Consult with Koster America for crack general repair guidelines.

B. Mapai Planiseal VS:

1. Repair cracks before application of the Planiseal VS using an appropriate high-modulus epoxy (Planibond EBA or Planibond CR 50) mixed with sand if required (depending on the size of crack under repair). Cracks narrower than 1/8" (3mm) may typically be filled with Planiseal VS neat. Cracks wider than 1/8" (3mm) are to be repaired with suitable high-modulus epoxy such as Planibond EBA or Planibond CR 50 (consider an epoxy mortar if appropriate) filled to 1/8" to 1/4" (3 to 6mm) shy of the substrate surface (just below flush).
2. Avoid overfilling of cracks with high-modulus epoxies that will lead to epoxy spilling onto substrate. Any epoxy that spills onto the substrate surface must be removed, and any remaining residue must be fully seeded with sand. The subsequent application of the Planiseal VS must take place after all loose sand have been vacuumed up off the floor, and fully encapsulate the epoxy utilized for crack repair.
3. Contraction, control or saw-cut joint treatment – Dormant control joints may typically be filled with Planiseal VS, or with Planibond EBA or Planibond CR 50 (consider an epoxy mortar if appropriate) filled to 1/8" to 1/4" (3 to 6mm) shy of the substrate surface (just below flush).

C. ARDEX MC:

1. Moving Joints – honor all expansion and isolation joints up through the ARDEX Moisture Control System, and underlayment or topping.
2. Saw cuts, control joints and dormant cracks – To ensure that a continuous barrier to moisture emissions is created over the entire surface, ARDEX recommends the use of a two-part, low viscosity rigid epoxy crack and joint filler to fill small, non-moving cracks and saw-cut joints in existing concrete substrates. Cracks greater than a hairline in width [1/32" (0.79 mm)] and saw-cuts must be filled in strict accordance with the installation instructions provided by the ARDEX Technical Department. Once the dormant cracks and saw-cuts have been properly filled, allow these areas to cure thoroughly in accordance with the epoxy manufacturer's recommendations prior to proceeding with the ARDEX MC™ PLUS installation.
3. Saw Cuts, Control Joints and Dormant Cracks – fill all non-moving joints and cracks greater than 1/32" with a rigid, low-viscosity, two-part epoxy joint sealant. Once the cracks and joints have been properly filled, broadcast a sand layer to refusal and allow these areas to cure as recommended by the epoxy manufacturer prior to proceeding with the installation of the ARDEX MC™ PLUS.

3.03 INSTALLATION (per manufacturer's guidelines or as follows)

- A. The coverage rates vary by system. Follow manufacturer recommendations for the specific project application.

- B. Application of moisture reduction system shall be in strict accordance with manufacturer recommended methods and installation information.
- C. Cementitious underlayment with suitable primer is recommended if required by the Owner, floor covering installer, or the floor covering manufacturer to smooth and/or level surfaces after shot blasting and installation of the moisture reduction system. No underlayment or feather finish system is allowed under the moisture reduction system material. When water based adhesives are utilized in the floor covering installation, use an approved cementitious underlayment system with primer prior to the installation of the flooring system. Contact the adhesive manufacturer for their minimum recommended thickness of cementitious underlayment to absorb excess moisture in the adhesive. Typically a minimum of 1/8" is required. Note this is only for some water based adhesives.

3.05 PROTECTION

- A. Prohibit any traffic or any activity that generates dust or debris from contaminating the treated slab until finished flooring is installed.
- B. Do not install finished flooring until the vapor control system has fully cured in accordance with manufacturer's recommendations.

END OF SECTION

**SECTION 07 51 13
BUILT-UP BITUMINOUS ROOFING REPAIR**

PART 1 - GENERAL

1.01 DESCRIPTION

A. Work Included:

1. Removal of portions of existing roof membrane in preparation for installation of new mechanical equipment and structural upgrades.
2. Installation of a new built-up bituminous roofing system patch at areas affected by new mechanical equipment and structural upgrades.

B. Related Work Specified Elsewhere:

1. Rough Carpentry 06 10 00.
2. Flashing and Sheet Metal 07 60 00.
3. HVAC supports and related items: See Mechanical and Electrical work.

1.02 ROOFING SYSTEMS

A. Unless otherwise noted or specified, built-up bituminous roofing systems are to be by one approved manufacturer utilizing hot asphalt and asphalt saturated glass fiber felts. System shall be mineral cap sheet surfaced and rated as Class A by Underwriters' Laboratories. Systems are to be 20 year or better quality for the particular deck, slope and installation indicated, all as per approved manufacturer's published specifications with limitations as per the following:

1. Roofing systems limited to those systems comprised of one (1) base sheet, three (3) ASTM-D 2178, Type IV glass felts and one (1) ASTM-D 3909 mineral cap sheet.
2. Means and Methods of repair of existing roofing systems shall be provided that maintain existing roofing warranties.

1.03 REFERENCES, CODES AND STANDARDS

A. The following references, codes and standards are hereby made a part of this Section and built-up roofing shall conform to the applicable requirements therein except as otherwise specified herein or shown on the Drawings. Nothing in the Drawings or these Specifications shall be construed as permitting work which is contrary to code requirements.

1. Underwriters' Laboratories, Inc. Building Materials Directory, "Built-Up Roof Covering Materials" and "Roof Deck Constructions", latest edition with current supplements.
2. California Building Code.

1.04 QUALIFICATION

A. Roofing systems shall be installed only by a qualified roofing contracting firm which has been in business for not less than five (5) years, is experienced in installing the roofing systems specified and is approved by the built-up roofing materials manufacturer.

1.05 PRE-ROOFING CONFERENCE

- A. Pre-roofing conference shall be scheduled by the Contractor in advance of commencing roofing work and ordering of materials. Conference shall be attended by Contractor, contractor for roofing, contractors for mechanical and electrical work, representative of the roofing manufacturer and representative of the Architect. Contractor shall make a written record of the conference proceedings, which record shall be made a part of the Job File. Copies shall be provided to all parties.
 - B. Project Specifications and Drawings and all roof and flashing details shall be reviewed and any discrepancies, including discrepancies with roofing manufacturer's specifications, resolved. Code and architectural requirements that are in conflict with UL requirements, shall likewise be resolved.
 - C. In addition to the above, the conference shall also address itself to the following:
 - 1. Establish trade related job schedules, including installation of roof mounted equipment.
 - 2. Establish roofing schedules and work methods that will prevent roof damage.
 - 3. Require all penetrations and curbs to be in place prior to installing roof.
 - 4. Establish areas on the job site to be used as work and storage areas.
 - 5. Establish weather and working conditions to which all parties must agree.
 - 6. Establish any requirements pertaining to temporary roofing.
 - 7. Establish provisions for monitoring of the roof after completion and prior to acceptance of the entire Project.
 - D. Where changes to any previously agreed upon conditions are desired, the party requesting the change shall:
 - 1. Give written notice regarding the desired change to all parties. Such request shall be made through the Contractor.
 - 2. Secure written agreement to changes from all parties.
- 1.06 SUBMITTALS: Comply with requirements of Shop Drawings, Product Data and Samples Section 01 33 00.
- A. Certificates:
 - 1. Submit, prior to commencing roofing work, evidence of acceptance of roof applicator by roofing manufacturer.
 - 2. Submit, prior to fabrication, delivery or installation, a statement that materials and components furnished; conform with Specification requirements and that materials and components furnished are compatible for the deck and slope indicated, each one to the other and to adjacent related work. Where manufacturer's systems are modified in any way by requirements of project Specifications, statement shall be submitted by the manufacturer accepting such modifications. Absence of such statements shall imply acceptance.
 - 3. Submit to the Architect, prior to acceptance of project, written certification that materials and workmanship pertaining to built-up roofing work are in accordance with the Drawings and specifications and approved manufacturer's requirements for the particular roofing

system.

- B. Manufacturer's Data: At least 30 days prior to commencing work, furnish to the Architect, two (2) copies of approved manufacturer's specifications for roofing and related flashing installations, listing specific materials proposed for each. Submittal data for asphalt shall specifically state the Equiviscous Temperature (EVT), COC Flash Point and Finished Blowing Temperature (FBT) for the particular asphalt(s) and type(s) to be used.
- C. Samples: Submit for approval of color of mineral cap sheet.

1.07 DELIVERY, STORAGE AND HANDLING OF MATERIALS

- A. Deliver materials to the work site in unopened packages bearing the manufacturer's label and U.L. listing mark (where applicable). Stencil softening point on each bitumen container. All materials, except fasteners, shall be labeled products of approved manufacturer.
- B. Stack rolls of felt and fabric on end on wood pallets in properly protected piles covered with tarpaulin and maintain at a temperature of 50° or over for a period of not less than 24 hours prior to laying. If polyethylene protection is used, it shall be properly vented. Felt and fabric shall be dry when applied.
- C. Store containers of bitumen on wood or other clean, rigid pads to prevent adherence of foreign materials.
- D. Bitumens delivered and stored in bulk shall be accompanied by a certificate of the manufacturer clearly stating the type, quality and softening point and shall be maintained in a manner so as not to alter their properties.
- E. Do not cause or permit construction materials or equipment to be used or stored in such manner or concentrations as to cause damage to built-up roofing.

1.08 JOB CONDITIONS

- A. Environmental Requirements: Apply roofing materials and components in dry weather and at ambient temperatures not less than 45°F. If below 45°F, consult manufacturer on procedures.
- B. Protection:
 1. Effectively protect buildings from damage by roofer's materials and/or operations. Take care to prevent bitumen from running into and clogging roof drains and rainwater leaders.
 2. It shall be the General Contractor's responsibility to protect the completed roofing work from damage due to construction operations. Where it is necessary to use completed work for traffic or for installation of other items of the whole work, and where protection is not otherwise specified herein, plywood on planks shall be provided so that storage of materials and traffic use does not occur directly on roofing.
 3. Submit, prior to fabrication, delivery or installation, a statement that materials and components furnished and applicator doing the work will maintain the existing roofing warranties.

1.09 PROTECTION OF BUILDING

- A. Protect building surfaces against damage from roofing work.

1.10 WARRANTY

- A. Unless superceded by compliance with an existing roofing warranty, The Roofing Contractor will guarantee all work (materials and labor) under this contract for 3 years in a written document containing the following paragraph:
- “If, within three years after the date of final payment, any of the work of this Contract is found to be defective, or not according to the specifications, the Contractor will correct the work within 30 days after receipt of written notice from the Owner to do so. In an emergency leaking condition, the Contractor shall make temporary repairs within 24 hours of telephone or written notice and complete permanent repairs within 14 days, all at no cost to the Owner. Contractor shall provide the prompt repair and replacement of all component materials or systems that admit water or otherwise malfunction, including consequent damage to the building and its contents”.
- B. Work shall be warranted against, but not limited to, leakage, displacement, buckling, tearing, splitting, alligating, blistering, and pulling loose.
- C. The Roofing Manufacturer will guarantee the roof against leaks and system failure under this contract for a period of 20 years and NDL in a written document.
- D. The Roofing Manufacturer will guarantee that the existing roofing warranty is still valid after installation of new work for full remaining period of existing warranty.

PART 2 - PRODUCTS

2.01 MATERIALS

- A. Roofing for slopes to 1” Mineral Surfaced Roof System, Johns Manville 5GNC or equal as required to maintain existing roof warranty:
1. Sheet Materials:
 - a. Glass Fiber Felts ASTM D 2178: Type VI. Johns Manville GlasPly Premier.
 - b. Base Sheet: ASTM D 4601, asphalt saturated and coated inorganic base sheet. Johns Manville PermaPly 28.
 - c. Mineral Surfaced Felts: ASTM D 3909; white colored mineral granules. Johns Manville GlasKap.
 - d. Dry Sheathing Paper: Red rosin paper, unsaturated.
 2. Bituminous Materials:
 - a. Asphalt Bitumen: ASTM D 312, Type III Trumbull TruLo
 - b. Plastic Cement: ASTM D 4586, Type II, cutback asphalt type. Johns Manville Bestile/Industrial Cement.
 3. Flexible Flashings:
 - a. Sheet Flashing: Rubber modified bitumen sheet containing two polyester mats and a fibrous glass mesh; DynaFlex manufactured by Johns Manville.
 - b. Flashing specifications DFE 3 WL as listed in the current Johns Manville specification manual.

4. Cants:
 - a. Perlite Cant and Tapered Edge Strips: Asphalt impregnated perlite (Fes-Cant), preformed to 45 degree angle.
 5. Accessories:
 - a. Roofing Nails: 1 inch diameter head ringed shank nails, size as required to suit application.
 - b. Traffic Pads: Johns Manville DynaTred.
- B. Roofing for slopes to 2" Mineral Surfaced Roof System, Johns Manville 5GIC.
1. Sheet Materials:
 - a. Glass Fiber Felts: ASTM D 2178, Type VI, JM GlasPly Premier.
 - b. Mineral Surfaced Felts: ASTM D 3909; JM GlasKap white colored mineral granules.
 2. Bituminous Materials:
 - a. Asphalt Bitumen: ASTM D 312, Type III.
 - b. Bestile Industrial Cement.
 3. Flexible Flashings:
 - a. Sheet Flashing: Rubber modified bitumen sheet containing two polyester mats and a fibrous glass mesh; DynaFlex manufactured by Johns Manville. Flashing specifications DFE as listed in the current Johns Manville specification manual.
 4. Roof Surfacing:
 - a. Mineral Surfaced Cap Sheet: ASTM D-3909.
 5. Cants:
 - a. Perlite Cant and Tapered Edge Strips: Asphalt impregnated perlite (Fes-Cant), preformed to 45 degree angle.
 6. Accessories:
 - a. Roofing Nails: 1 inch diameter head ringed shank.
 - b. Traffic Pads: Johns Manville Dyna-Tred.
 - c. A premium No. 12 hexhead roof insulation fastener coated with ClimaSeal for superior corrosion resistance. UltraFast is required on all Johns Manville guaranteed systems using insulation over metal or other nailable decks. To be used with UltraFast Locking Plastic Plates or UltraFast Galvalume Metal Plates.

2.02 Rigid Insulation

- A. Insulation: Johns-Manville – Fesco Board, or approved equal conforming to ASTM C728-05;

expanded perlite mineral aggregate board; R-Value 2.78 per inch, 10% Consolidation - 40 PSI. Board size per manufacturer's standard sizes. Board edges square. Compression resistance to be per ASTM C165 – 20 psi. Total board thickness as required to match thickness of existing installation where occurs, Johns-Manville – Tapered Fesco Board, or approved equal where required to match existing installation where occurs, or to form new roof slopes or crickets where indicated on the drawings. Tapered insulation board shall match slope of existing installation where occurs, new installations shall be furnished with a minimum slope of 1/4-inch per foot unless noted otherwise on the drawings.

PART 3 - EXECUTION

3.01 EXAMINATION

- A. Verify that surfaces and site conditions are ready to receive work.
- B. Verify that deck is supported and secured.
- C. Verify flatness and tight joints of wood decking. Fill knot holes with latex filler.
- D. Verify that roof openings, curbs, pipes, sleeves, ducts, and vents through roof are solidly set, and wood cant strips and reglets are in place.
- E. Verify if existing rigid insulation occurs below existing membrane.
- F. Beginning of installation means installer accepts existing substrate.

3.02 MEMBRANE APPLICATION FOR SLOPES TO 1"; JOHNS MANVILLE 5GNC or approved equal and means and methods as may be required to maintain existing warranty.

- A. Using Perma Ply 28 base sheet starting at the low edge of roof apply one 18" wide. The following base sheet courses are to be applied full width, lapping the preceding felt 2" on the side laps and 4" on the end laps. Nail the side laps 9" o.c. down the longitudinal center of each felt, place two rows of nails spaced approximately 11" apart, with the nails staggered on approximately 18" centers. Use nails or fasteners appropriate to the type of deck with 1" minimum diameter caps.
- B. Using GlasPly Premier felt apply a piece 12" wide, then over that, one 24", then over both, a full width piece. The following felts are to be applied full width, overlapping the preceding felts by 2-2/3" so that at least 3 plies of felt cover the base felt/substrate at all locations. Install each felt so that it is firmly and uniformly set, without voids, into the hot asphalt (within 25 degrees F of the EVT) applied just before the felt at a nominal rate of 23 lbs. per square over the entire surface.
- C. Equiviscous Temperature at Point of Application: No more than 25 degrees F (14 degrees C) from bitumen rating indicated on bitumen container label.
- D. Apply Mineral Surface roof membrane by cutting the cap sheet into handleable lengths (12' – 18') and allow to flatten. Starting at the low edge of the roof area, apply one layer of the cap sheet in a full width mopping of hot asphalt (approx. 20 degrees F above the EVT to maximize bonding of the cap sheet to the ply sheets), also apply asphalt to the side lap areas on the backside of the cap sheet. Then flop the cap sheet into the hot asphalt. At ambient temperature below 70 degrees F. The cap sheet must be firmly and uniformly set into the hot asphalt with all edges well sealed.
- E. Apply felts smooth, free from air pockets, wrinkles, fishmouths, lap joints, or tears.
- F. Extend membrane felts to the top of cant strips and minimum of 2 inches (50 mm) onto vertical surfaces. Mop on one additional ply of felt and one ply of granular surfaced SBS flashing felt as base flashings over roofing membrane plies.

- G. Mop and seal two additional plies of felt around roof penetrations.
- H. Install traffic pads.
- I. Apply granular surfaced SBS flexible base flashings to seal membrane to vertical elements. Flashing specifications as listed in the current Johns Manville Roofing Manual DFE 3.
- J. Coordinate installation of roof drains and related flashings.
- K. Mop in and seal flashings and flanges of items penetrating membrane with two plies of felt.

3.03 MEMBRANE APPLICATION FOR SLOPES TO 2"; JOHNS MANVILLE 5GIC or approved equal to maintain existing warranty:

- A. Mechanically fasten with Ultrafast Fasteners 1" Fesco Board to the plywood deck.
- B. Lay insulation boards with edges in moderate contact without forcing. Cut insulation to fit neatly to perimeter blocking and around penetrations through the roof.
- C. Mechanically fasten boards per FM I-90 (although no rating applies).
- D. Apply no more insulation than can be sealed with membrane in same day.
- E. Starting at the low edge of roof one 12 inch wide, then over that one 24 inch wide, then over both a full 36 inch wide GlasPly Premier, following felts to be applied full width, overlapping each felt 24 2/3 inches giving a minimum of 3 plies cover the insulation in all locations. Install each felt so that it shall be firmly and uniformly set, without voids, into the hot asphalt (within 25 degrees F of the EVT) applied just before the felt at a nominal uniform rate of 23 lbs. per square over the entire surface.
- F. Equiviscous Temperature at Point of Application: No more than 25 degrees F (14 degrees C) from bitumen rating indicated on bitumen container label.
- G. Apply Mineral Surface roof membrane by cutting the cap sheet into handleable lengths (12' – 18') and allow to flatten. When nailing is required, cut the cap sheet into lengths which conform to the nailer spacing. Starting at the low edge of the roof area, apply one layer of the cap sheet in a full width mopping of hot asphalt (approx. 20 degrees F above the EVT to maximize bonding of the cap sheet to the ply sheets), also apply asphalt to the side lap area on the backside of the cap sheet. Then flop the cap sheet into the hot asphalt. At ambient temperature below 70 degrees F. The cap sheet must be firmly and uniformly set into the hot asphalt with all edges well sealed.
- H. Apply felts smooth, free from air pockets, wrinkles, fishmouths, lap joints, or tears.
- I. Extend ply membrane felts to the top of cant strips and minimum of 2 inches (50 mm) onto vertical surfaces. Mop on one additional ply of felt and one ply of granular surfaced SBS flashing felt as base flashings over roofing membrane plies.
- J. Mop and seal two additional plies of felt around roof penetrations.
- K. Install traffic pads.
- L. Apply granular surfaced SBS flexible base flashings to seal membrane to vertical elements. Flashing specifications as listed in the current Johns Manville Roofing Manual.
- M. Coordinate installation of roof drains, sumps and related flashings.

- N. Mop in and seal flashings and flanges of items penetrating membrane with two plies of felt.

3.04 CLEANING

- A. Remove bituminous markings from finished surfaces.
- B. In areas where finished surfaces are soiled by asphalt or any other source of soiling caused by work of this Section, consult manufacturer of surfaces for cleaning advice and conform to their [documented] instructions.
- C. Repair or replace defaced or disfigured finishes caused by work of this Section.

3.05 RIGID INSULATION

- A. Where existing rigid insulation occurs, and cannot be salvaged for re-use, install new rigid insulation to match thickness of existing. Fasten with mechanical screw fasteners in full accordance with manufacturer's written instructions. Tape all joints prior to installation of new roofing. If existing insulation can be removed and re-installed without damage to existing product, and such re-use will not prevent full compliance with Paragraph 1.10 – Warrantee, it may be reinstalled with mechanical screw fasteners in full accordance with manufacturer's written instructions.

3.06 PROTECTION

- A. Where traffic must continue over finished roof installation, protect surfaces.

END OF SECTION

**SECTION 07 60 00
FLASHING AND SHEET METAL**

The General Conditions, Supplementary Conditions and Division 1 General Requirements are hereby made a part of this Section as fully as if repeated herein.

PART 1 - GENERAL

1.01 DESCRIPTION:

- A. Work Included: All sheet metal work as indicated and specified except those items included in other Sections. This Section includes but is not limited to:
 - 1. Flashings at door and window heads (drips) and sills.
 - 2. Roof gutters.
 - 3. All caulking and sealants related to sheet metal work.
 - 4. Downspouts.
- B. Related Work Specified Elsewhere:
 - 1. Built-up Bituminous Roofing Repair 07 51 13.
 - 2. Painting 09 91 00.
 - 3. Ductwork and flashing and counter flashing of all pipe, conduits and other penetrations of mechanical and electrical equipment.

1.02 REFERENCES AND STANDARDS: The following references and standards are hereby made a part of this Section and all sheet metal work shall conform to the applicable requirements and recommendations therein except as otherwise specified herein or shown on the Drawings.

- A. "Architectural Sheet Metal Manual", Latest Edition, and "Architectural Sheet Metal Specifications", latest Edition, both published by Sheet Metal and Air Conditioning Contractors' National Association, Inc. (SMACNA).

1.03 SUBMITTALS: Comply with requirements of Shop Drawings, Product Data and Samples Section.

- A. Shop Drawings: Show manner of forming, jointing and securing to adjacent work. Detail all waterproof connections including penetrations. Indicate all materials, thicknesses and dimensions, fastening and anchoring methods, details and locations of all seams, joints and other provisions necessary for thermal expansion and contraction.

1.04 DELIVERY, STORAGE AND HANDLING:

- A. Deliver all items to site unpainted and in sufficient time to enable incorporation into work of other trades.
- B. Store all galvanized metal under dry conditions and protect from moisture until installation commences.

PART 2 - PRODUCTS

2.01 MATERIALS:

- A. Galvanized Sheet Steel: ASTM A 525-77 and A 526-71, 1.25 oz. galvanized coating, 24 gage unless otherwise noted, except 22 ga. or heavier at caps and parapets. Where exposed and to be painted, use mill-phosphatized material. Use lock-forming quality (ASTM A 527) where so required by nature of fabrication. Gutters 20 gauge.
- B. Solder: ASTM B 32-76, half lead and half tin (Alloy 50A).
- C. Flux: Muriatic acid cut with zinc or non-corrosive, as recommended for use with parent metals.
- D. Fastenings: Tinned or galvanized for galvanized metal; hard copper for lead. All nails into wood shall be annular ring type with large heads.
- E. Insulating Materials:
 - 1. Asphalt Saturated Felt: ASTM D 226-77, No. 30 type.
 - 2. Bituminous Coating (Sheet Lead): F.S. TT-C-494 or MIL-C-18480.
- F. Caulking and Sealing:
 - 1. For all concealed metal to metal contact, use polyisobutylene type, non-skinning, non-drying sealant, bulk or tape, as required by installation conditions (tape: 1" minimum width, 1/16" minimum thickness); Presstite "579 Series", PPG "Duribbon 1072", or approved equal.
 - 2. At all other areas requiring calking and sealing, conform to silicone sealant material requirements of Caulking and Sealants Section.
- G. Downspouts – Schedule 40 PVC with 3 clamp supports downspout.

PART 3 - EXECUTION

3.01 CONDITION OF SURFACES:

- A. Surfaces to receive sheet metal work shall be smooth, clean, and dry and free of rough or sharp ridges and projections. Nails shall be driven flush without projecting heads.
- B. Commencing installation implies acceptance of surfaces.

3.02 COORDINATION:

- A. Coordinate and schedule sheet metal work with installation of roofing, drains, piping, blocking, nailers, framed openings, curbs, parapets and other adjoining or substrate work where it is integral or contiguous therewith.
- B. Instruct other trades concerning location and placement of nailers, blocking, cleats, etc.

3.03 PREPARATION:

- A. Remove all grease, dirt and surface coatings from surfaces to be soldered.
- B. Apply all galvanized sheet metal over redwood, cedar, or oak over one layer of saturated felt; or, alternately, the metal may be back painted with a heavy coat of bituminous paint.

3.04 INSTALLATION:

- A. Where work is not otherwise shown or specified, conform to details and requirements set forth in the Reference Standards.
- B. Where materials or construction systems are specified with reference to a particular manufacturer (such as reglets, gravity ventilators and calking and sealants, make all installations in strict accord with the approved manufacturer's installation instructions.
- C. Except where otherwise noted or specified, all sheet metal work shall be galvanized sheet steel. Make all cleats and edge strips of the same metal as items with which they are used.
- D. Accurately reproduce profiles and bends; make intersections sharp, even and true. Make plain surfaces free from buckles and waves with as few joints as possible. Reinforce all work as required for strength and appearance.
- E. Bend all metals to minimum radius recommended by manufacturer for thickness used. (In general, the radius shall be not less than the thickness of metal.)
- F. Provide for proper expansion and contraction in all systems. Make all joints tight. Conceal all nails and other fastenings where possible. Face nailing through exposed surfaces is not permitted unless specifically shown. Secure exposed edges to underlying materials with clips or tabs (edge strips).
- G. Make all seams in direction of flow.
- H. Hem all exposed edges of sheet metal work ½ inch.
- I. Do all cutting, fitting, punching, etc., in sheet metal to accommodate work specified elsewhere and provide all necessary accessory items.
- J. Properly apply caulking and sealants to sheet metal items to permit movement between surfaces and to make entire installation watertight. Conform to requirements of Caulking and Sealants Section.
- K. Soldering: Roughen smooth surfaces with clean emery cloth or sandpaper; do not use steel wool. Use torch or well headed irons for all soldering. Solder slowly throughly heating seams and completely sweating solder through full width with at least 1" of solder

evenly flowed along seams. Wherever possible, solder in a flat position. Solder seams on slopes greater than 45° a second time. Solder immediately after application of flux; after soldering, immediately neutralize any corrosive flux with 5% soda solution and flush with clean water. Soldering of exposed surfaces shall be neatly done. Exposed solder shall be dressed and finished. Soldering shall be employed only to seal or fill seams. Where structural strength is required, do not rely on solder alone but use supplementary

mechanical fasteners.

L. Flashings:

1. Install all flashings required to provide watertight protection. Except where composition flashings are used, flash intersections of decks and roofs or other horizontal surfaces with vertical surfaces of every kind. Make flashings base and counter type or cap type unless otherwise shown.
2. Assemble and install flashings at roofing and conditions to conform to approved manufacturer's recommendations and the requirements of the Built-Up Roofing Section.
3. Carry all flashings around corners 4" minimum; metal soldered or otherwise joined at the angle is not permitted. Three-way an shall have the corners soldered watertight.
4. Roof flashings and related metal shall be installed with flanges on top ply of roofing felt and reinforced as per Roofing Section. Installation of flange below or between roofing plies is not permitted.
5. Unless metal manufacturer has more stringent requirements, make up continuous straight runs of flashings in 24 ft. maximum lengths. Unless otherwise shown or specified, connect continuous runs together with 3-inch loose lock expansion joints sealed water-tight with sealant. Provide expansion joints at 10 ft. maximum from any external or internal corners, and in straight runs less than 24 ft. but more than 10 ft., make expansion joints at center of run. Running joints between expansion joints shall be locked and soldered or lapped and riveted/soldered.

3.05 PROTECTION: Protect dissimilar metals subject to galvanic corrosion from contact with each other and from other surfaces which cause corrosion of metal.

END OF SECTION

**SECTION 07840
FIRESTOPPING**

PART 1 - GENERAL

1.01 APPLICABLE REQUIREMENTS:

- A. The requirements of Section 00 70 00, Section 00 80 00 and Division 1 apply to all work of this Section.

1.02 SCOPE:

- A. Safing Insulation in Wall and Floor/Ceiling Construction.
- B. Firestop Sealants and Caulks.
- C. Firestop Putty and Putty Pads.
- D. Firestop Spray.
- E. Firestop Collars.
- F. Large Openings.
- G. Cast-in-Place Firestop Devices
- H. Intumescent Wrap.
- I. Firestop Mortar.

1.03 RELATED WORK SPECIFIED ELSEWHERE:

- A. Section 03 30 00 Cast-in-Place Concrete
- B. Section 07 90 00 Sealants
- C. Section 09 25 00 Gypsum Wallboard
- D. Division 15 Mechanical
- E. Division 16 Electrical

1.04 REFERENCES:

- A. ASTM E84 – Test Method for Surface Burning Characteristics of Building Materials.
- B. ASTM E119 – Method for Fire Tests of Building Construction and Materials.
- C. ASTM E814 – Test Method of Fire Tests of Through Penetration Firestops.
- D. ASTM E1399 – Standard Test Methods for Cyclic Movement and Measuring of Joint Systems.
- E. ASTM E1725 – Standard Test Methods of Fire-Resistive Barrier Systems of Electrical Systems Components.
- F. ASTM E1966 – Standard Test Methods for Fire Tests of Joints.
- G. FM (Factory Mutual Engineering Corporation) – Fire Hazard Classifications.

- H. UL (Underwriters Laboratories, Inc) – Fire Resistance Directory.
 - 1. Through-Penetration Firestop Devices (XHCR)
 - 2. Fire Resistance Ratings (BXUV)
 - 3. Through-Penetration Firestop Systems (XHEZ)
 - 4. Fill, Voids or Cavity Material (XHHW)
 - 5. Forming Materials (XHKU)
 - 6. Joint Systems (XHBN)
 - I. UL 263 (Underwriters Laboratories, Inc.) – Fire Tests of Building Construction and Materials.
 - J. UL 723 (Underwriters Laboratories, Inc.) – Test for Surface Burning Characteristics of Building Materials.
 - K. UL 1479 (Underwriters Laboratories, Inc.) – Fire Tests of Through-Penetration Firestops.
 - L. UL 2079 – Tests for Fire Resistance of Building Joint Systems.
 - M. CBC, 2001 edition, Section 714 – Through-Penetration Fire Stops.
 - N. WH (Warnock Hersey) – Directory of Listed Products.
 - O. 2001 California Electrical Code.
 - P. NFPA 80 – Standard Firedoor and Window Assembly Tolerances.
 - Q. NFPA 252 – Standard Fire Test for Fire-Rated Doors (Not Specified for Positive or Negative Furnace Test Pressure).
 - R. NFPA 257 – Standard Fire Test for Fire-Rated Windows (Not Specified for Position or Negative Furnace Test Pressure).
- 1.05 SUBMITTALS:
- A. Submit under provisions of Section 00 70 00 and 01 33 00.
 - B. Provide Manufacturer's Brochures describing insulation proposed for use, and types of mechanical fasteners to be used in the installation of the insulation.
 - C. Certificates of Compliance: Before any insulation material is installed Contractor shall furnish to the Architect a certificate certifying that materials to be incorporated in the work conform in all respects to the specification requirements as outlined herein.
 - D. Submit manufacturer's product literature and installation procedures for each type of Firestop material to be installed. Literature shall indicate product characteristics, typical uses, performance and limitation criteria, and test data. Submit cured samples of firestop materials.
 - E. Shop drawings: Show typical installation details for the methods of installation. Indicate which firestop materials will be used where and application requirements to meet specific jobsite conditions.

- F. Manufacturer's engineering judgment identification number and drawing details when no UL system is available for an application. Engineering judgment must include both project name and name of contractor who will install firestop system as described in drawing.

1.06 QUALITY ASSURANCE:

- A. Requirements of Regulatory Agencies: Materials and installation shall comply with requirements of governing regulations and authorities.
- B. Firestopping systems (materials and design) shall be F-rated to meet the hourly rating of the wall or floor as tested by nationally accepted test agencies per ASTM E814 or UL 1479 in a configuration representative of field conditions. T-ratings for walls and floors shall be as required in the 2010 CBC Sections 709 and 710.
- C. Unless specified and approved, no pipe insulation shall be removed; all insulation shall remain intact, continuous and undamaged when firestopped.
- D. A manufacturer's direct representative (not distributor or agent) shall be on-site during initial installation of firestop systems to train appropriate contractor personnel in proper selection and installation procedures. This shall be done per manufacturer's written recommendations published in their literature and drawings details.
- E. Firestop Systems do not reestablish the structural integrity of load-bearing partitions/assemblies, or support live loads and traffic. Installer shall consult the structural engineer prior to penetrating any load-bearing or shear wall assembly.
- F. For those firestop applications that exist for which no UL tested system is available through any manufacturer, a manufacturer's engineering judgment derived from similar UL system designs or other tests will be submitted to local authorities having jurisdiction for their review and approval prior to installation. Engineer judgment drawings must follow requirements set forth by the International Firestop Council (September 7, 1994).

1.07 DEFINITION:

- A. Firestopping: Material or combination of materials used to retain integrity of fire-rated construction by maintaining an effective barrier against the spread of flame, smoke, water and hot gases through penetrations in fire-rated wall and floor assemblies.

1.08 SYSTEM DESCRIPTION:

- A. Firestopping Materials: ASTM E84, ASTM E119, ASTM E814, ASTM E1399, ASTM E1966, UL 263, UL 1479 and UL 2079 to achieve a fire rating as noted on Drawings.
- B. Surface Burning: ASTM E84, UL 723. Flame Spread: 5 maximum, Smoke Density: 15 maximum.
- C. Firestop all interruptions to fire rated assemblies, materials, and components whether detailed on the Drawings or not. Fire rate assemblies shall be maintained in full conformance with Code requirements.

1.09 DELIVERY, STORAGE AND HANDLING:

- A. Deliver materials to the project site in the manufacturer's original packaging. Clearly identify as to the name of the manufacturer, the contents, brand name, applicable standard, lot number, UL label and mixing and installation instructions.
- B. Store materials off-ground and protect against weather, condensation and damage. Immediately remove damaged or deteriorated materials from the job site.

- C. All firestop materials shall be installed prior to expiration of shelf life.
- D. Do not install damaged or expired materials.

1.10 SCHEDULING:

- A. Coordinate installation with other trades whose work may be affected or have effect.

1.11 PROJECT CONDITIONS:

- A. Conform to manufacturer's printed instructions for installation and, when applicable, curing in accordance with temperature and humidity. Conform to ventilation and safety requirements.
- B. Do not use materials that contain flammable solvents.
- C. Schedule installation of firestopping after completion of penetrating item installation but prior to covering or concealing of openings.
- D. Verify existing conditions and substrates before starting work. Correct unsatisfactory conditions before proceeding.
- E. Weather conditions: Do not proceed with installation of firestop materials when temperatures exceed the manufacturer's recommended limitations for installation printed on product label and product data sheet.
- F. During installation, provide masking and drop cloths to prevent firestopping materials from contaminating any adjacent surfaces.

1.12 INSTALLER QUALIFICATIONS:

- A. Engage an experienced Installer who is certified, licensed or otherwise qualified by the firestopping manufacturer as having the necessary experience, staff and training to install manufacturer's products per specified requirements. A manufacturer's willingness to sell its firestopping products to the Contractor or to an Installer engaged by the Contractor does not, in itself, confer qualification on the buyer.

PART 2 PRODUCTS

2.01 GENERAL:

- A. Provide and install firestopping materials to meet applicable codes and installation requirements for each firestopping application. Products using caulking, putty, wrap strips, mortar, composite boards and/or mechanical devices shall be used as appropriate for the specific condition. Firestop all interruptions to fire rated assemblies, materials, and components whether detailed on the Drawings or not. Fire rate assemblies shall be maintained in full conformance with Code requirements.
- B. When caulking is used, provide and install flexible caulking materials. Cured firestop materials 1/8" thick shall be able to bend around a 1" mandrel without breaking.
- C. Do not use any firestop products that re-emulsify or leach active intumescent.
- D. Provide materials that can be reused (pillows or non-curing putty) for all telephone and data penetrations.
- E. Provide firestopping composed of components that are compatible with each other, the substrates forming openings and the items, if any, penetrating the firestopping under conditions of service and

application, as demonstrated by the firestopping manufacturer based on testing and field experience.

- F. Provide components for each firestopping system that is needed to install fill material. Use only components specified by the firestopping manufacturer and approved by the qualified testing agency for the designated fire-resistance rated systems.
- G. Provide a firestop system with an "F" rating as determined by UL 1479 or ASTM E814 that is equal to the time rating of construction being penetrated.
- H. Provide a firestop system with an Assembly Rating as determined by UL 2079 that is equal to the time rating of construction being penetrated.

2.02 MINERAL WOOL INSULATION:

- A. Through penetrations: Provide 4 pcf mineral wool per tested system.
- B. Head of wall construction gaps: Provide 4 pcf mineral wool per tested system.
- C. Perimeter safing slot: Provide 4 pcf mineral wool batt insulation per tested system.
- D. Accessories: Provide all accessories and anchors for installation as recommended by the manufacturer.

2.03 FIRESTOP SEALANT – For penetrations by noncombustible items including steel pipe, copper pipe, rigid steel conduit and electrical metallic tubing (EMT), the following materials are acceptable:

- A. Manufacturers:
 1. Hilti. Product: FS-One.
 2. STI, Spec Seal. Product: Series 100 Sealant.
 3. 3M. Product: Fire Barrier CP25WB+.
 4. Tremco. Product: TREMstop IA Sealant.
 5. Substitutions: Under provisions of Section 00700.
- B. Sealant shall be a one-part intumescent latex compound. The sealant when exposed to high heat or flame shall be capable of expanding to seal off annular spaces created. Range of continuing expansion shall be from 230°F to greater than 1,000°F. The sealant shall be thixotropic and shall be capable of caulking or troweling onto vertical surfaces or overhead. The sealant shall be UL Classified (UL 1479) and tested to the requirements of ASTM E814. Penetrations in fire rated assemblies shall be protected and sealed in accordance with CBC Chapter 7.

2.04 ELASTOMERIC FIRESTOP SEALANT – For openings between structurally separate sections of wall and floors. At top-of-walls, the following materials are acceptable:

- A. Manufacturers:
 1. Hilti. Product: CP601S.
 2. STI, Spec Seal. Product: Series ES100 Elastomeric Sealant.
 3. 3M. Products: Fire Barrier Sealants 1000, 1003, 2000, 2003, 2000+ and 2001.

4. Tremco Product: Dymeric 511
 5. Substitutions: Under provisions of Section 00700.
- B. Elastomeric sealant shall be a non-halogenated, latex-based, highly flexible caulk. The sealant shall be thixotropic for high-build application using standard caulking equipment or by troweling onto vertical surfaces or overhead. The sealant shall be UL Classified (UL 2079) and tested to the requirements of ASTM E814. Closures in fire rated assemblies shall be protected and sealed in accordance with CBC Chapter 7.
- 2.05 FIRESTOP PUTTY – For penetrations by combustible items (penetrants consumed by high heat and flame) including insulated metal pipe, PVC jacketed flexible cable, or cable bundles and plastic pipe (closed piping systems), the following materials are acceptable:
- A. Manufacturers:
 1. Hilti. Product: CP617 and CP618.
 2. STI, Spec Seal. Product: Putty.
 3. 3M. Product: Fire Barrier Moldable Putty +.
 4. Tremco. Product: Tremstop WB Intumescent Firestop Sealant.
 5. Substitutions: Under provisions of Section 00700.
 - B. Putty shall be a one-part intumescent, non-hardening compound. The putty, when exposed to high heat or flame shall be capable of expanding to seal off annular spaces created. Range of continuing expansion shall be from 230°F to greater than 1,000°F. The putty shall be soft and pliable with aggressive adhesion. The putty shall be UL Classified (UL 1479) and tested to the requirements of ASTM E814. Penetrations in fire rated assemblies shall be protected and sealed in accordance with CBC Chapter 7.
- 2.06 FLEXIBLE FIRESTOP SPRAY – For fire-rated construction joints and other gaps, the following materials are acceptable:
- A. Manufacturers:
 1. Hilti. Product: CP672.
 2. 3M. Products: Firedam Spray and Fire Barrier Spray.
 3. STI, SpecSeal.
 4. Tremco. Product: TREMstop Acrylic, Sprayable Grade
 5. Substitutions: Under provisions of Section 00700.
 - B. Spray shall be flexible, sprayable water-based coating that dries in ambient conditions to form a flexible seal that will compress/extend with the intended range of the joint. The spray shall be UL classified (UL 2079) and tested to the requirements of ASTM E1399 and ASTM E1966. Closures in fire rated assemblies shall be protected and sealed in accordance with CBC Chapter 7.
- 2.07 FIRESTOP COLLARS – For penetrations by combustible plastic pipe (opening piping systems), the following materials are acceptable:
- A. Manufacturers:

1. Hilti. Product: CP642/CP643 Firestop Jacket.
 2. 3M. Products: Fire Barrier PPD Plastic Pipe Device and Ultra Plastic Pipe Device.
 3. Tremco. Product: TREMstop D
 4. Substitutions: Under provisions of Section 00700.
- B. Firestop collar shall be made of a galvanized steel housing and shall contain section of intumescent material. The material shall be designed to expand when exposed to fire. The collars shall be UL classified (UL 1479) and tested to the requirements of ASTM E814. Closures in fire rated assemblies shall be protected and sealed in accordance with CBC Chapter 7.
- 2.08 LARGE OPENINGS – For large size, complex penetrations made to accommodate cable trays, multiple steel and copper pipes and electrical busways in raceways, the following materials are acceptable:
- A. Manufacturers:
1. Hilti. Product: Fire Block.
 2. 3M. Product: Fire Barrier CS-195+ and Composite Sheet.
 3. Tremco Product: TREMstop PS
 4. Substitutions: Under provisions of Section 00700.
- B. For large openings, install intumescent compound. The intumescent compound, when exposed to high heat or flame, shall be capable of expanding to seal off annular spaces created. Product shall be UL classified (UL 1479) and tested to the requirements of ASTM E814. Closures in fire rated assemblies shall be protected and sealed in accordance with CBC Chapter 7.
- 2.09 CAST-IN-PLACE FIRESTOP DEVICES – for use with non-combustible and combustible plastic pipe (closed and open piping systems) penetrating concrete floors, the following products are acceptable:
- A. Manufacturers:
1. Hilti. Product: CP 680 Cast-in-Place Firestop Device.
 2. Tremco, Product: Fyrecan
 3. Proset
 4. Substitutions: Under provisions of Section 00700.
- B. Acceptable penetrations: Sealing pipes and cables up to 6” in diameter in penetration through fire-rated floors, suitable for: vented or closed plastic pipes, PVC, CPVC, ABS, innerduct, FRPP, steel, cast-iron, copper pipes, insulated steel and copper pipes, EMT and ENT electrical conduits, bundled cables, blank openings.
- 2.10 INTUMESCENT WRAP –
- A. Manufacturers:
1. Hilti. Product: CP645 Firestop Intumescent Wrap Strip.

2. Substitutions: Under provisions of Section 00700.
- 2.11 FIRESTOP MORTAR – Fire-resistant, cement-based mortar for firestop-sealing medium-sized to large openings with non-combustible pipes or cable trays, and permanent fire seal for cables, cable trays and non-combustible pipes. For use with concrete and masonry assemblies, and for walls and floors rated up to 3 hours.
- A. Manufacturers:
 1. Hilti. Product: FS 635 Trowable Firestop Compound.
 2. Substitutions: Under provisions of Section 00700.
- 2.12 ACCESSORIES:
- A. Installation Accessories: Clips, collars, fasteners, temporary stops or dams, and other devices required to position and retain materials in place.

PART 3- EXECUTION

- 3.01 CONDITIONS REQUIRING FIRESTOPPING:
- A. General:
 1. Provide firestopping for conditions specified whether or not firestopping is indicated or detailed on the Drawings and, if indicated, whether such material is designed as insulation, safing or otherwise.
 - B. Penetrations:
 1. Penetrations include conduit, cable wire, pipe, duct or other elements that pass through one or both outer surfaces of a fire-rated floor, wall or partition.
 2. These requirements for penetrations shall apply whether or not sleeves have been provided, and whether or not penetrations are to be equipped with escutcheons or other trim. If penetrations are sleeved, firestop annular space, if any, between sleeve and wall opening.
 - C. Provide firestopping to fill miscellaneous voids and openings in fire-rated construction as specified herein.
- 3.02 EXAMINATION:
- A. Verify site conditions under provisions of Section 00700.
 - B. Verify openings are ready to receive the work of this section.
- 3.03 PREPARATION:
- A. Clean substrate surfaces of dirt, dust, grease, oil, loose material or other matter that may affect bond of firestopping material.
 - B. Remove incompatible materials that may affect bond.
 - C. Install noncombustible backing materials to arrest liquid material leakage.

- D. Examine the areas and conditions where firestops are to be installed and notify the Architect of conditions detrimental to the proper and timely completion of the work. Do not proceed with work until unsatisfactory conditions have been corrected by the Contractor in a manner acceptable to the Architect.
- E. Verify penetrations are properly sized and in suitable condition for application of materials.
- F. Provide masking and temporary covering to prevent soiling of adjacent surfaces by firestopping materials.
- G. Comply with manufacturer's recommendations for temperature and humidity conditions before, during and after installation of firestopping.

3.04 INSTALLATION:

A. General

- 1. Installation of firestops shall be performed by an applicator/installer qualified and trained by the manufacturer. Installation shall be performed in strict accordance with manufacturer's detailed installation procedures. Written verification of the manufacturer's training shall be submitted to the Architect.
- 2. Apply firestops in accordance with fire test reports, fire resistance requirements, acceptable sample installations and manufacturer's recommendations.
- 3. Provide sprinkler piping with NFPA 13 required annular space using insulation and firestop to allow movement.
- 4. Coordinate with plumbing, mechanical, electrical and other trades to assure that all pipe, conduit, cable and other items which penetrate fire-rated construction have been permanently installed prior to installation of firestops.

B. Regulatory Requirements: Install firestop materials in accordance with published "Through-Penetration Firestop Systems" in UL's Fire Resistance Directory.

C. Manufacturer's Instructions: Comply with manufacturer's instructions for installation of through-penetration materials.

- 1. Seal all holes or voids made by penetrations to ensure an air- and water-resistant seal.
- 2. Protect materials from damage on surfaces subjected to traffic.

D. Field Quality Control

- 1. Prepare and install firestopping systems in accordance with manufacturer's printed instructions and recommendations.
- 2. Follow safety procedures recommended in the Material Safety Data sheets.
- 3. Finish surfaces of firestopping which are to remain exposed in the completed work to a uniform and level condition.
- 4. All areas of work must be accessible until inspection by the applicable Code authorities.
- 5. Correct unacceptable firestop installations and provide additional inspection to verify compliance with this specification at no additional cost.
- 6. All firestop assemblies shall be identified with a permanently affixed ID label.

7. Examine sealed penetration areas to ensure proper installation before concealing or enclosing areas.
 8. Keep areas of work accessible until inspection by applicable code authorities.
 9. Perform under this section patching and repairing of firestopping caused by cutting or penetrating of existing firestop systems already installed by other trades.
- E. Installation shall be completed in a neat, workmanlike manner according to manufacturer's recommendations. Securely fasten and anchor insulation in place to prevent displacement or sagging of material. Safing insulation shall be adequately lapped.
 - F. Install material at fire rated horizontal to vertical assembly closures and at fire rated walls or partition openings which contain penetrating sleeves, piping, ductwork, conduit and other items requiring firestopping.
 - G. Apply primer and materials in accordance with manufacturer's instructions.
 - H. Apply firestopping material in sufficient thickness to achieve rating.
 - I. Compress fibered material to achieve a density of 40% of its uncompressed density.
 - J. Dam material to remain.

3.05 CLEANING:

- A. Clean Work under provisions of Section 00 70 00.
- B. Clean adjacent surfaces of firestopping materials.
- C. Remove spilled and excess materials adjacent to firestopping without damaging adjacent surfaces.
- D. Leave finished work in a neat and clean condition with no evidence of spillovers or damage to adjacent surfaces.

3.06 PROTECTION OF FINISHED WORK:

- A. Protect finished Work from any damage by continued work.
- B. Protect adjacent surfaces from damage by material installation.
- C. Where firestopping is installed at locations which will remain exposed in the completed work, provide protection as necessary to prevent damage to adjacent surfaces and finishes, and protect as necessary against damage from other construction activities.

END OF SECTION

**SECTION 07 92 00
JOINT SEALANTS**

The General Conditions, Supplementary Conditions and Division 1 General Requirements are hereby made a part of this Section as fully as if repeated herein.

PART 1 - GENERAL

1.01 DESCRIPTION:

- A. Work Included: All caulking and sealant work required for the project and not specified elsewhere.
- B. Related Work Specified Elsewhere:
 - 1. Caulking and sealants related to the following:
 - a. Section 07 60 00 Flashing and Sheet Metal.
 - b. Section XX XX XX Fire Safing

1.02 QUALIFICATION: All exterior, elastomeric type sealants shall be applied by a firm normally in the business of applying sealants similar to those specified.

1.03 SUBMITTALS: Comply with requirements of Shop Drawings, Product Data and Samples Section 01 33 00.

- A. Samples: Samples of all exposed caulking and sealants are required for Architect's approval of colors. Unless otherwise directed, apply samples in 6-inch runs in actual joints at the job site.
- B. Manufacturer's Specifications and Materials List: At least 30 days prior to commencing work, furnish to Architect, 2 copies of manufacturer's specifications for installations indicated, listing specific materials proposed. Specifications shall indicate completely, recommendations for use of primers, joint preparation and sealant dimensions.

1.04 PRODUCT HANDLING:

- A. Delivery: Deliver caulking and sealants and related accessories to the job site in factory sealed, unopened containers bearing manufacturer's name and product designation.
- B. Storage: Store in unopened containers. Follow manufacturer's recommendations for storage temperatures and shelf life.
- C. Handling: Follow manufacturer's recommendations for handling products containing toxic materials. Keep flammable material away from heat, sparks and open flame. Use recommended solvents and cleaning agents for cleaning tools, equipment and skin.

1.05 ENVIRONMENTAL CONDITIONS: Schedule caulking and sealing operations so that working joints are most likely to be normal size. Apply materials within manufacturer's recommended surface and ambient temperature ranges.

1.06 PROTECTION: Use masking tape where practical to control lap of materials onto adjacent surface or to facilitate tooling. Remove tape immediately after caulking and sealing.

PART 2 - PRODUCTS

2.01 MATERIALS:

- A. General: All caulking and sealants, primers and accessories shall be non-staining to adjacent exposed materials. Products having similar application and usage shall be of the same manufacturer and type. Unless otherwise specified, colors will be selected from approved manufacturer's standard range. Use gun consistency compounds unless otherwise required by job conditions.
- B. Silicone Sealant: Silicone Sealant (use at concrete, masonry, and all glazing applications): FS TT-S-01543, Class A, low modulus type; Spectrum I as manufactured by Tremco, Inc.
- C. Interior Building Sealant: Acrylic-emulsion; one-part, nonsag, mildew-resistant. Complying with ASTM C834-10, formulated to be paintable; Pecora Corp. "AC-20", Sonneborn "Sonolac", Tremco Inc. "Tremco Acrylic Latex 834" or approved equal.
- D. Sanitary Sealant: One-part mildew-resistant silicone (use at all restroom locations and wet areas); ASTM C920 Type S; Grade NS Class 25; Uses NT, G, A and O; formulated with fungicide for sealing interior joints with nonporous substrates around ceramic tile, showers, sinks and plumbing fixtures; Dow Corning Corp. "786 Mildew Resistant", Sonneborn Building Product Div. "Sonoolastic Omniplus" or approved equal.
- E. Acoustical Sealant for Concealed Joints (use at all joints in interior wall applications where joint is not covered by gypsum wallboard tape): Nondrying, nonhardening, nonskinning, nonstaining, gunnable, synthetic rubber sealant recommended for sealing interior concealed joints to reduce transmission of airborne sound; Pecora Corp. "BA-98", Tremco Inc. "Tremco Acoustical Sealant" or approved equal.
- F. Acoustical Sealant for Exposed Joints (use at all joints in interior wall applications where joint is not covered by gypsum wallboard tape): Nonoxidizing, skinnable, paintable, gunnable sealant recommended for sealing interior exposed joints to reduce transmission of airborne sound; Pecora Corp. "AC-20", USG "Sheetrock Acoustical Sealant" or approved equal.
- G. Sheet Metal Flashings, Trims, Gutters, & Joints: Joint sealing material shall be a two-component, self-leveling, polyurethane elastomeric sealant. Product shall be Sikaflex 2cSL as manufactured Sika Corporation, or equal. Color shall be chosen from the full range of manufacturer's standard colors. Provide Sikaflex 260 Primer at all stainless steel and/or galvanized substrate location for proper adhesion of Sikaflex 2cSL.
- H. Butyl Sealant: One component, butyl based sealant, skinning type; DAP "Butyl-Flex", Pecora BC-158, Tresco "Butyl Sealant", or approved equal.
- I. Silicone Sealant (Exterior): One component, low modulus, silicone based sealant; Dow-Corning "790", General Electric "Silpruf", or approved equal.
- J. Silicone Sealant (Interior): Dow-Corning "8640", or approved equal, white color.
- K. Primers (If required): As manufactured and recommended for each substrate by approved manufacturer of each caulking and sealant material used.
- L. Back-Up Materials: As recommended for and compatible with each caulking and sealant used. In general, use closed cell, bead or rope shaped, expanded polyethylene or polyurethane foam. Do not use any bituminous, oily or solvent containing materials or any incompressible materials. In general, width or diameter of preformed; back-up material shall be 1-1/3 to 1-1/2 times the width of the joint to be sealed.
- M. Release Materials: Polyethylene film.

PART 3 - EXECUTION**3.1 CONDITION OF SURFACES:**

- A. Inspect all surfaces to receive caulking and sealant materials and report all defects. Starting work implies acceptance of surfaces as satisfactory.
- B. Verify that joints and spaces to be caulked or sealed is of proper width.
- C. Concrete, masonry, and plaster surfaces shall be thoroughly cured.
- D. Apply no caulking or sealant materials in contact with surfaces contaminated with oil, grease, bituminous materials, form release agents, bond breakers, and deleterious curing compounds, water repellents and other special surface treatments. Aluminum surfaces shall be free of lacquer and other oxidizing coatings. Costs occasioned by removal of such contaminants shall be responsibility of the trade having caused their presence.

3.02 PREPARATION:

- A. Thoroughly clean all joints, removing all foreign matter such as dirt, dust, moisture, frost, rust, mill scale, paint, lacquer and protective coatings. Blow all joints free of loose particles.
- B. Use no cleaning solvents which leave residue. Wipe joints free of solvent using clean, dry white cloths or white lintless paper. Do not permit solvent to air dry.
- C. Follow the Manufacturer's directions for products and surfaces.

3.03 INSTALLATION:

- A. Unless otherwise required by these Specifications, install materials in strict accordance with Manufacturer's specifications and recommendations using approved equipment.
- B. Usage:
 - 1. Use butyl sealant for all interior static joints not otherwise noted.
 - 2. Use interior type silicone sealant for caulking around ceramic tile and similar conditions (vertical surfaces).
 - 3. Use exterior type silicone sealant for all joints not otherwise noted or specified.
- C. Prime surfaces as recommended by manufacturer immediately prior to caulking or sealing. Make preliminary tests to ensure that primers will not stain exposed materials or deteriorate back-up material.
- D. Unless otherwise required by caulking and sealant manufacturer's specifications and recommendations, use back-up material to control caulking and sealant depths as follows (depths measured at bond face):
 - 1. Silicone Sealants (Exterior): Make depth half of width but not less than 3/16" or more than 3/8".
 - 2. Do not twist or stretch preformed bead or rope type back-up material during installation.
- E. At joints subject to movement, where required by nature of back-up material used or where sealant contacts back of joint, use release material between back-up material or

back of joint and sealant to confine adhesion to surfaces of materials being joined. Follow manufacturer's recommendations exactly. Release material is not required over polyethylene backing.

- F. Neatly tool joints to slightly concave surface using tooling agent recommended by sealant manufacturer. Repair any air pockets exposed by tooling. Tool so as to compress material and improve adhesion to surfaces joined.
- 3.04 PATCHING: Patch or replace defective or damaged sealants. Be responsible for damage to adjacent surfaces caused by caulking and sealant operations.
- 3.05 CLEANING: Clean adjacent surfaces soiled by caulking and sealing operations. Remove wet material before it "sets". Follow manufacturer's recommendations for cleaning procedures. Cleaning agents shall not stain or be injurious to exposed surfaces nor shall they be potentially dangerous to glass and metal surfaces due to wash-off by rain.

END OF SECTION

**SECTION 08 11 00
METAL DOORS AND FRAMES**

PART 1 – GENERAL

1.01 SECTION INCLUDES

- A. Non-Rated and Rated Steel Doors.
- B. Non-rated and Rated Metal Frames.
- C. Door Glazing.
- D. Door Louvers.

1.02 RELATED SECTIONS

- A. Section 00 70 00: General Conditions.
- B. Exhibits C, D, G Abatement of Hazardous Materials.
- C. Section 06 10 00: Rough Carpentry: Framed Opening.
- D. Section 08 71 00: Door Hardware.
- E. Section 09 90 00: Painting and Coatings.

1.03 REFERENCES

- A. ANSI/SDI-100 - Standard Steel Doors and Frames.
- B. ANSI Z97.1 - Safety Performance Specifications and Methods of Test for Safety Glazing Used in Buildings.
- C. ASTM A366/A366M-97e1 - Steel, Sheet, Carbon, Cold-Rolled, Commercial Quality.
- D. ASTM A924 / A924M-09a - General Requirements for Steel Sheet, Metallic-Coated by the Hot-Dip Process.
- E. ASTM A1011 / A1011M-09b - Steel, Sheet and Strip, Hot Rolled, Carbon, Structural, High-Strength Low-Alloy High Strength Low Alloy with Improved Formability, and Ultra-High Strength
- F. ASTM A1008 – Standard Specifications for Steel Sheet, Cold -Rolled, Carbon, Structural, High-Strength Low-Alloy and High-Strength Low-Alloy with Improved Formability.
- G. ASTM A568 – Standard Specifications for Sheet Steel and Strip, Carbon, and High-Strength, Low-Alloy, Hot-Rolled and Cold-Rolled, General Requirements for

1.04 QUALITY ASSURANCE

- A. Provide door and frame complying with Steel Door Institute "Recommended Specifications for Standard Steel Door and Frames" (SDI 100), and as herein specified.
- B. Fire-rated door and frame assemblies shall be in accordance with ASTM E2074-00e1 and labeled

by U.L., Factory Mutual, Warnock Hersey, or other acceptable testing and inspecting organization having jurisdiction.

- C. All doors requiring fire rating shall conform to the California State Fire Marshal Standard 12-43.4 Fire Rated Door Tests.
- D. All metal doors shall have a 20-minute minimum fire rating and be labeled accordingly. See Door/Frame/Hardware schedule for additional requirements.

1.05 SUBMITTALS

- A. Submit under provisions of Section 01 33 00.
- B. Shop Drawings: Include illustrations and schedule of finish hardware, door and frame size, type, material, construction, finishing, anchoring, accessories, and preparation for installing hardware.
 - 1. Method of attachment of frames to structure shall be approved by Architect.
- C. Templates: Furnish hardware templates to fabricator of frames and doors to be factory prepared for installation of hardware.
- D. General Contractor to confirm field measurements of all openings prior to submittal and fabrication of doors and frames.

1.06 PRODUCT DELIVERY AND STORAGE

- A. Deliver all materials under protective cover and store in upright position within a dry enclosed space in a manner that will prevent rust and damage. Do not create a humidity chamber by using a plastic or canvas shelter that is not adequately vented.

PART 2 – PRODUCTS

2.01 MANUFACTURERS

- A. Steelcraft Manufacturing Co.
 - a. Doors: L Series with Polystyrene Core
 - b. Frames: F Series
- B. Curries Doors
 - a. Doors: 707 Series
 - b. Frames: M Series
- C. Ceco
 - a. Doors: Legion Series
 - b. Frames: S Series
- D. Approved Equal

2.02 MATERIALS

- A. Hot-Rolled Steel Sheets and Strip for Frames: Commercial quality carbon steel, complying with ASTM A1011 / A1011M-09b.
- B. Cold-Rolled Steel Sheets for Doors: Commercial quality carbon steel, complying with ASTM A1008 / A1008M-09a.
- C. Factory Applied Primer Paint: Manufacturer standard rust inhibitor primer.

2.03 METAL DOOR FABRICATION

- A. General: Fabricate to sizes shown, providing necessary clearances and bevels to permit operation without binding. Door shall be free from warp, wave, buckle or other defect. Field verify size of all doors.
1. Flush Door Construction: Door shall be fabricated with face sheets of 16 gauge steel. Weld face sheets 2 inches on center, minimum. Door shall be flush with edge seams filled and ground smooth. Bevel lock and hinge edges 1/8" in 2". Door shall be provided with top and bottom inverted 16 gauge steel channels welded within the door. Door shall be polystyrene core. No exposed seams shall occur on the door face or vertical edge. The top and bottom of the door shall be closed with a recessed channel and flush end closure treatment.
- B. Preparation of Hardware: Door shall be mortised, reinforced, drilled and tapped at the factory from templates for all mortise hardware listed in the hardware schedule. Door shall be reinforced only for surface applied hardware such as closers, checks, escutcheons and kickplates, the drilling and tapping for which is to be done in the field by the door erector. Reinforcement shall consist of 12 gauge for locksets and latchsets, and 14 gauge for surface applied hardware, except butts, which shall have 3/16" thick plate. Door shall be provided with reinforcing unit as recommended by lock manufacturer. A continuous 12 ga. reinforcement shall be provided for continuous hinge prep and installation.
- C. Hardware Mounting Heights and Door Clearances: In accordance with ANSI Industry Standards.
- D. All louvers shall be installed minimum 10" above finished floor to edge of louver flange as required for accessibility requirements.

2.04 METAL FRAME FABRICATION

- A. General: Pressed metal frames shall be formed to shapes shown. General Contractor to field verify size of all frames. Head and jambs are to be notched, mitered, fully welded and finished to present a smooth surface for painting.
1. Frames shall be fabricated from 16 gauge galvanized A60 steel, and shall be designed with integral rabbet, stop and trim.
 2. At locations where existing wood/metal door frame is being replaced in existing wall, knock-down frames are acceptable. Contractor shall shim between rough opening and new frame as required.
- B. Anchors: Frame shall be securely anchored to wooden structures with spot welded anchor straps and to existing masonry structure with masonry fasteners, punched and dimpled frames. Where anchorage is not specifically delineated, anchorage shall be as for a similar assembly, or approved manufacturer's standard type, to securely fasten frames to wall construction involved (wire anchors not acceptable); also provide adjustable floor anchor at bottom of each door jamb. Provide minimum 3 anchors, equally spaced, at jamb end of frames. Anchors shall provide stiffness and rigidity to keep frames square, in accurate position without twisting, buckling or warping.
- C. Preparation for Hardware: Frames shall be prepared at the factory for all hardware using templates furnished by hardware supplier. Locations of miscellaneous hardware shall conform to the recommendations for the Door and Hardware Institute. Mortise, reinforce, drill and tap for all

mortise type hardware. Reinforce for surface applied hardware, the drilling and tapping for which is to be done in the field door erector.

1. All hardware cutouts shall have steel plate reinforcements with tapped holes welded to frame. Reinforcement shall include 3/16" butt reinforcement; 12 gauge lock strike; 14 gauge for surface applied items.
 2. Provide for three (3) rubber door silencers at single doors and (2) silencers at head of pair doors. Omit holes at frames to receive unitized weatherstripping; refer to Section 08712.
- D. Combination and Window Frames: Furnish units for fixed glass, fabricated to the designs and dimensions indicated. Provide metal glazing stops and mouldings for field assembly with countersunk oval head self-tapping screws spaced not over 16 inches o.c. Frames shall be complete with anchors.
- E. Rated Doors and Frames: All fire rated doors and frames shall have a metal label, permanently fastened to the jamb indicating the fire rating and Test Agency name. Do not apply primer or paint over fire rating labels.

2.05 FINISH

- A. All surfaces shall be cleaned, phosphatized, and given one coat rust-inhibiting prime paint in accordance with the Steel Door Institute Specification "Test Procedure and Acceptance Criteria for Primer Painted Steel Doors and Frames".
- B. Field paint doors and frames under provisions of Section 09 90 00.

2.06 ACCESSORIES

- A. Door Vision Panels: 20 ga. cold rolled steel, for 1-3/4" doors, unless otherwise noted use with 1/4" thick glazing, prime coat finish for field painting. Size as shown on drawings.
1. Anemostat LoPro Metal Vision Frame.
 2. Air Louvers Inc. Model VSL – Slimline.

PART 3 – EXECUTION

3.01 INSTALLATION

- A. Set Frame level and plumb, and brace adequately to prevent damage or distortion. Secure standard height frames to structure with minimum of three anchors at each jamb. Provide one additional anchor per 18" above standard height.
1. Attach to wooden structure with 16d nails on both sides of each strap into stud.
 2. Attach to existing masonry structure with masonry anchors of appropriate length to penetrate masonry a minimum of 2". Bondo screw heads, sand smooth to conceal fasteners.
 3. Removable Spreaders: Size opening by inserting wood spreader cut to the exact opening width and fasten sill anchor at strike jamb with nails or screws. Remove spreader. Insert adjusting screw cover.

4. If knock-down frame is used, contractor shall shim between new frame and existing rough opening. Gap shall be fully filled all around frame.
- B. Door Installation: Fit hollow door accurately in the frame with a tolerance of 1/8" at jamb and head.
- C. Fit hollow metal door in existing wood framed opening (jamb) with a tolerance of 1/8" at jamb and head.

3.02 ERECTION TOLERANCES

- A. Maximum Diagonal Distortion: 1/16 inch measured with straight edge, corner to corner.
- B. New doors shall have maximum 3/8" undercut above finished floor with no threshold and 3/4" undercut above finished floor with threshold.

3.03 ADJUST AND CLEAN

- A. Prime Coat Touch-Up: Immediately after erection, sand smooth all rusted or damaged areas of prime coat and apply touch-up of compatible air-drying primer. Touch-up shall not be obvious.
- B. Cleaning and Finishing: Upon completion of the work, clean all exposed surfaces, removing any discoloration or foreign matter, and touch up all abraded or cut areas and exposed edges with finishing material recommended by the manufacturer. Touch-up of finish shall not be obvious.
- C. Final Adjustments: Check and readjust operating finish hardware in hollow metal work just prior to final inspection. Leave work in complete and proper operating condition.
- D. Defective Work: Remove and replace defective work, including doors and frames which are warped, bowed or otherwise damaged as directed by the Architect, with no additional cost to the Owner.
- E. Protection: Protect installed hollow metal work against damage from other construction work.

3.04 CLEAN-UP

- A. Upon completion of the work of this section, remove all excess materials, rubbish and debris from the premises.

END OF SECTION

**SECTION 08 14 16
FLUSH WOOD DOORS**

PART 1 – GENERAL

1.01 SECTION INCLUDES

- A. Flush wood doors; flush and flush glazed configuration.
- B. Rated and Non-Rated.
- C. Door Vision Panels.

1.02 RELATED SECTIONS

- A. Section 00 70 00: General Conditions.
- B. Section 06 20 00: Finish Carpentry.
- C. Section 08 11 00: Metal Doors and Frames: Steel door frames.
- D. Section 08 71 00: Door Hardware.
- E. Section 09 90 00: Painting and Coatings: Site finishing doors.

1.03 REFERENCES

- A. ANSI A135.4 - Basic Hardboard.
- B. ANSI/HPMA HP - Hardwood and Decorative Plywood.
- C. ASTM E413-04 - Rating Sound Insulation.
- D. AWS – Architectural Woodwork Standards.

1.04 SUBMITTALS

- A. Submit under provisions of Section 01 33 00.
- B. Shop Drawings: Illustrate door opening criteria, elevations, sizes, types, swings, undercuts required, special beveling, special blocking for hardware, and identify cutouts for glazing. Contractor shall be responsible for field verifying all finish door dimensions to fit existing frame conditions prior to the submittal of shop drawings.
- C. Product Data: Indicate door core materials and construction; veneer species, type and characteristics; factory machining criteria, factory finishing criteria.
- D. Samples: Submit two samples of door veneer, 8 x 10 inch in size illustrating wood grain.
- E. Contractor to confirm field measurements of all openings prior to submittals and fabrication of doors and frames.

1.05 QUALITY ASSURANCE

- A. Perform work in accordance with AWS Custom Grade.

1.06 QUALIFICATIONS

- A. Manufacturer: Company specializing in manufacturing the Products specified in this section with minimum three years experience.

1.07 REGULATORY REQUIREMENTS

- A. Fire Door Construction: Conform to California Building Code, Chapter 7.
- B. Where opening has fire resistive rating of 20 minutes or longer, door shall bear testing agency-issued label for indicated rating. Do not prime or paint over fire rating labels.
- C. NFPA Standard No. 80.

1.08 DELIVERY, STORAGE, AND HANDLING

- A. Deliver, store, protect, and handle products to site under provisions of Section 00 70 00.
- B. Accept doors on site in manufacturer's packaging. Inspect for damage.

1.09 FIELD MEASUREMENTS

- A. Verify that field measurements are as indicated on shop drawings.

1.10 COORDINATION

- A. Coordinate the work with door opening construction, door frame and door hardware installation.

1.11 WARRANTY

- A. Provide warranty under provisions of Section 00 70 00 to the following term:
 - 1. Interior Doors: Lifetime.
- B. Include coverage for delamination of veneer, warping or twisting (not to exceed 1/4 inch in any face including diagonal) or other defects. Warranty shall cover replacement of door plus costs of hanging and finishing.

PART 2 – PRODUCTS

2.01 MANUFACTURERS

- A. Algoma Hardwoods, Inc.
- B. VT Industries
- C. Graham Manufacturing

D. Or approved equal.

2.02 DOOR TYPES

A. Flush Interior Doors: 1-3/4 thick; solid core construction as indicated.

B. Faces: Stain grade birch veneer for transparent finish. Use solid stock for exposed edges to match face veneer. Face veneers for pairs of doors shall be selected for color and grain match.

2.03 DOOR CONSTRUCTION

A. Solid Core, Non-Rated:

1. Core: **LD1** or **LD2** cores, Type 2 or better.
2. Stiles: Minimum 1-1/4 inch with two ply edge strips glued to core, outer ply of hardwood.
3. Top and bottom rails: Minimum 1-1/4 inch two ply end strips glued to core.
4. Crossbands: 1/16 inch thick veneer.
5. Faces: Tempered 2S2, 1/8 inch hardboard for opaque finish.
6. Veneer: Flush veneered, five-ply construction.
7. Glue: Type 2 or better.

B. Fire Resistive Doors with 20 minute Fire Rating: Construction shall be similar to Solid Core Doors, and have fire rating of not less than 20 minutes when tested in accordance with California Building Code, Chapter 7 without hose stream test. Doors shall have 6 inch top rail. All doors scheduled to receive flush bolts and kick plates shall have an extra wide bottom rail to provide necessary strength for installation of the hardware requirements.

C. Fire Resistive Doors with 3/4 Hour or Longer Fire Ratings: Meet requirements of California Building Code, Chapter 7 and ASTM F152-95(2009) for fire-rating noted.

1. Core: Mineral Composition.
2. Category: B
3. Stiles and Top Rail: Firestop material as rated per manufacturer.

2.04 ADHESIVE

A. Facing Adhesive: Type 2 or better.

2.05 ACCESSORIES

A. Door Vision Panels: 20 ga.cold rolled steel, for 1-3/4" doors, unless otherwise noted use with 1/4" thick glazing, prime coat finish for field painting. Size as shown on drawings.

1. Anemostat LoPro Metal Vision Frame.

2. Air Louvers Inc. Model VSL – Slimline.
3. Or Equal.

2.06 FABRICATION

- A. Fabricate non-rated doors in accordance with AWS.
- B. Provide hardware reinforcement for hardware specified in Section 08 71 00.
- C. Fit door edge trim to edge of stiles after applying veneer facing.
- D. Bond edge banding to cores.
- E. Factory machine doors for finish hardware in accordance with hardware requirements and dimensions. Do not machine for surface hardware. Provide solid blocking for through bolted hardware.
- F. Undercut doors 3/8 inch maximum above finish floor.
- G. Glass Cutouts: Provide cutouts for glass of size and shape indicated.
- H. Fabricate and install doors in fire-rated frames in accordance with requirements of NFPA Standard No. 80(2007).
- I. All louvers shall be installed minimum 10” above finished floor to edge of louver flange as required for accessibility requirements.

2.07 FINISH

- A. All doors with transparent finish to be factory pre-finished, equal to TR6.
- B. Apply seal coat at both ends of doors prior to final installation.

PART 3 – EXECUTION

3.01 EXAMINATION

- A. Field verify frame opening conditions and sizes.
- B. Do not install doors in frame openings that are not plumb or are out-of-tolerance for size or alignment.

3.02 INSTALLATION

- A. Install rated and non-rated doors in accordance with AWS, NFPA 80, and U.L. requirements.
- B. Trim non-rated door width by cutting equally on both jamb edges.
- C. Trim door height by cutting bottom edges to a maximum of 3/4 inch.
- D. Pilot drill screw and bolt holes.

- E. Factory prep for hardware.
- F. Coordinate installation of doors with installation of frames specified in Section 08 11 00 and hardware specified in Section 08 71 00. Coordinate the installation of new wood doors in existing wood or metal frames. Contractor shall be responsible for field verifying all finish door dimensions to fit existing frame conditions prior to the submittal of shop drawings.

3.03 INSTALLATION TOLERANCES

- A. Maximum Diagonal Distortion (Warp): 1/8 inch measured with straight edge or taugt string, corner to corner, over an imaginary 36 x 84 inch surface area.
- B. Maximum Vertical Distortion (Bow): 1/8 inch measured with straight edge or taugt string, top to bottom, over an imaginary 36 x 84 inch surface area.
- C. Maximum Width Distortion (Cup): 1/8 inch measured with straight edge or taugt string, edge to edge, over an imaginary 36 x 84 inch surface area.
- D. Doors to have a maximum tolerance of 1/8" between door and frame at jambs and head.
- E. Doors shall have maximum 3/8" undercut above sill surface or floor finish.

3.04 ADJUSTING

- A. Adjust work under provisions of Section 00 70 00.
- B. Adjust door for smooth and balanced door movement.

END OF SECTION

**SECTION 08 31 11
ACCESS DOORS AND FRAMES**

PART 1 – GENERAL

1.01 SECTION INCLUDES

- A. Access panels for in-wall plumbing items.
- B. Large access panels for entry to plumbing chase.

1.02 RELATED SECTIONS

- A. Section 00 70 00: General Conditions.
- B. Section 06 41 16: Plastic Laminate Clad Architectural Cabinets (for coordination of access panel lock keying with cabinet lock keying).
- C. Section 07 90 00: Joint Protection: Sealant and back-up material.
- D. Section 09 21 16: Gypsum Board Assemblies.
- E. Section 09 92 16: Vinyl Coated Fabric Wall Coverings
- F. Division 22: Plumbing.

1.03 SUBMITTALS

- A. Submit under provisions of Section 01 33 00.
- B. Product Data on panel size including material thickness, hinge type, lock type and engraved identification plate.
- C. Attachment and finishing details.

1.04 FIELD MEASUREMENTS

- A. Verify that field measurements are as indicated on shop Drawings.

1.05 COORDINATION

- A. Coordinate Work with plumbing valve locations and sizes, wall openings, and adjacent Work.

PART 2 – PRODUCTS

2.01 GENERAL

- A. All access panels shall be gray prime-painted steel. Contractor to field finish paint.

2.02 ACCESS PANEL TYPES

- A. Flush Type: Door style is flush with provision to conceal flange with drywall cement. 16 gauge

steel frame, 14 gauge door panel. Minimum size 10"x10", U.O.N. on drawings. Special, double-acting concealed spring hinges to allow 175 degree opening. Provide with optional cylinder locks at all locations and key to casework keys for room where access panel is located.

1. Style-DW by Milcor.
 2. WB DW 400 by Williams Brother Corporation of America.
 3. Or equal.
- B. Engraved Identification Plate: At each access panel used for access to gas valves, provide solid acrylic engraved identification plate with all capital letters minimum 1" high (red background with white letters) to read, "ROOM GAS SHUT-OFF VALVE", or as otherwise indicated on the Drawings.

PART 3 – EXECUTION

3.01 EXAMINATION

- A. Verify prepared openings for adequacy to access panel.
- B. Verify that openings for panels are correctly sized and within tolerance.
- C. Verify that surfaces of gypsum board and/or finished surfaces are clean, free of obstructions, and ready to receive panels.
- D. Report in writing to, any conditions that may be detrimental to the Work.

3.02 PREPARATION

- A. Contractor shall install blocking/backing in wall as required for correct anchorage of access panel.
- B. Prior to final anchorage of panel, Contractor shall confirm that all shutoff valves rotate freely behind panel. Bending of valve levers as a means to rotate freely is not acceptable.
- C. Prior to final anchorage of large chase access panel, Contractor shall review locations of piping in wall and that access to chase is not blocked by piping.

3.03 INSTALLATION

- A. General: Install panels at locations indicated, according to manufacturer's recommendations and as specified herein.
- B. Fill all anchorage hole in panels. Screws shall penetrate blocking minimum 1".
- C. Set all panels level and plumb in wall.
- D. Contractor shall carefully cover drywall bead on all panels with concealed flanges. Clean all drywall mud from face of panel and inside panel frame.
- E. At access panels set in vinyl wall paneling, secure access panel flange to plywood substrate centered on recessed gas shutoff valve. Butt paneling tight to panel flange.

- F. Securely fasten engraved name plate centered on door.

3.04 CLEANING

- A. Clean work under provisions of 00 70 00.
- B. Remove drywall and grout materials from finish surfaces.
- C. Remove labels after work is complete.
- D. Clean stainless steel surfaces.

3.05 PROTECTION OF FINISHED WORK

- A. Protect finished Work under provisions of Section 00 70 00.
- B. Replacement: At completion of building construction and prior to its acceptance, all broken, dented, excessively scratched, or otherwise imperfect finished surfaces included under this Section shall be replaced with new panels of the type specified, as directed by the Architect, and at no additional cost to the Owner.

END OF SECTION

RFQ/RFP 1617 - Attachment C
SECTION 08 33 26
OVERHEAD COILING DOORS

PART 1 - GENERAL

1.01 SECTION INCLUDES

- A. Overhead coiling fire door including all coiling curtains, bottom bars, guides, hoods operating mechanisms and accessories.
- B. Interface with building fire alarm system.

1.02 RELATED SECTIONS

- A. Section 00 70 00: General Conditions.
- B. Section 06 10 11: Rough Carpentry
- C. Division 16: For connection to building fire alarm system.

1.03 SUBMITTALS

- A. Submit under provisions of Section 01 33 00.
- B. Product Data on panel size including material thickness, hinge type, lock type and engraved identification plate.
- C. Attachment and finishing details.

1.04 Quality Assurance

- A. All rolling fire doors shall be constructed in accordance with an approved testing agencies requirements and shall bear a 1-1/2 hour rating label. Firelocks shall be installed on doors over 13'-7" wide but not exceeding 29'-7" wide to positively hold the curtain in the guides.

PART 2 - PRODUCTS

2.01 Manufacturers

- A. Cookson Company, Type FD-3S Crank Operated Fire Door, face of wall mounted with factory-finish paint.
- B. Overhead Door Company, 631 Series FireKing Fire Door.
- C. Or approved equal.

2.01 Materials

- A. The door curtain shall be constructed of interconnected strip steel slats conforming to ASTM A-653. The proper gauge of steel shall be chosen as follows:
 - 1. 22 gauge with a No. 5 (measuring 2-1/4" high by 5/8" deep) flat slat as designated by The Cookson Company.
- B. The finish on the door curtain shall be Cookson FinalCote consisting of the following:

1. Thermosetting polyester top coat with a minimum thickness of .6 mils each side. Color to be selected from manufacturer's full range of standard colors.
- C. The bottom bar shall consist of two 1/8" steel angles mechanically joined together. The finish on the bottom bar shall be factory applied Thermosetting Bronze ColorCote applied with a minimum thickness of 2 mils.
 - D. The guides shall consist of 3 steel angles bolted together with 3/8" fasteners to form a channel for the curtain to travel. The wall angle portion shall be continuous and fastened to the surrounding structure with either minimum 1/2" fasteners or welds, both on 36" centers. The finish on the guide angles shall be factory applied Thermosetting Bronze ColorCote applied with a minimum thickness of 2 mils.
 - E. The brackets shall be constructed of steel not less than 1/4" thick and shall be bolted to the wall angle with minimum 1/2" fasteners. The finish on the brackets shall be factory applied Thermosetting Bronze ColorCote applied with a minimum thickness of 2 mils.
 - F. The barrel shall be steel tubing of not less than 4" in diameter. Oil tempered torsion springs shall be capable of correctly counter balancing the weight of the curtain and shall have both a main and an auxiliary spring. The barrel shall be designed to limit the maximum deflection to .03" per foot of opening width. The springs shall be adjusted by means of an exterior wheel. The barrel shall be unpainted.
 - G. The hood shall be fabricated from 24 gauge galvanized steel and shall be formed to fit the curvature of the brackets. The finish on the hood shall be the Cookson FinalCote finish as indicated in the curtain section.

2.02 Operation

- A. The Simple-Test Crank Operated Fire Door shall have a combination crank / controlled closing system operator including removable hand crank and geared reduction unit. Integral to the unit is a locking mechanism to hold the door at any position during normal door operation mode and a governor to control automatic closing speed.
 1. Automatic closure shall be activated by fusible link and also be connected to campus fire alarm system with optional Firefly releasing device. Provide and connect Firefly III (Cookson) release device or Fire Sentinel Model FSXP (Overhead Door Company) as shown on drawings.
 2. Door shall maintain a closing speed of not less than 6" nor more than 12" per second during normal and automatic closure.
 3. Resetting of spring tension or mechanical dropouts shall not be required. Door shall be reset by replacing and reconnecting the fusible link.
- B. Crank operated doors shall open and close with a maximum of 25 pounds of effort.

PART 3 - EXECUTION

3.01 Installation

- A. All Cookson Rolling Fire Doors shall be installed in accordance with NFPA Bulletin 80 by an authorized Cookson Distributor.
- B. Touch up all visibly damaged painted surfaces.

3.02 Training

- A. Door manufacture shall provide training to District personnel on operation of doors including resetting of doors after fire alarm system has been activated, to alleviate the necessity of calling the roll-down door company representative to visit the site to reset the doors.
- B. Provide training to District personnel on adjustments for roll down speed and fire alarm delay times.

3.03 Warranty

- A. All Cookson Rolling Fire Doors shall be warranted for a period of 2 years from the time of shipment against defects in workmanship and materials.

END OF SECTION

SECTION 08 51 13
ALUMINUM WINDOWS

PART 1 GENERAL

1.1 SECTION INCLUDES

- A. Projected window units and glazing for replacement applications.

1.2 RELATED SECTIONS

- A. Section 06 20 00 Finish Carpentry.
- B. Section 07 92 00 Joint Sealants.

1.3 REFERENCES

- A. AAMA - American Architectural Manufacturers Association:
 - 1. AAMA/ WDMA/CSA 101/I.S.2/ A440-08 "Standard/Specification for windows, doors, and unit skylights".
 - 2. AAMA 502-11 "Voluntary Specification for Field Testing of Newly Installed Fenestration Products".
 - 3. AAMA 611-98 "Voluntary Specification for Anodized Architectural Aluminum".
 - 4. AAMA 701/702-11 "Voluntary Specification for Pile Weatherstripping and Replaceable Fenestration Weatherseals".
 - 5. AAMA 800-10 "Voluntary Specifications and Test Methods for Sealants".
 - 6. AAMA 1503-09 "Voluntary Test Method for Thermal Transmittance and Condensation Resistance of Windows, Doors, and Glazed Wall Sections".
 - 7. AAMA 2605-11 "Voluntary Specification, Performance Requirements and Test Procedures for Superior Performing Organic Coatings on Aluminum Extrusions and Panels"
 - 8. AAMA CW-10-04 "Care and Handling of Architectural Aluminum from Shop to Site"
- B. ASTM International:
 - 1. ASTM E90-09 "Standard Test Method for Laboratory Measurement of Airborne Sound Transmission Loss of Building Partitions and Elements".
 - 2. ASTM E283-04 "Standard Test Method for Determining Rate of Air Leakage Through Exterior Windows, Curtain Walls, and Doors Under Specified Pressure Differences Across the Specimen".
 - 3. ASTM E330-10 "Standard Test Method for Structural Performance of Exterior Windows, Doors, Skylights, and Curtain Walls by Uniform Static Air Pressure Difference".
 - 4. ASTM E331-09 "Standard Test Method for Water Penetration of Exterior Windows, Skylights, Doors, and Curtain Walls by Uniform Static Air Pressure Difference".
 - 5. ASTM E547-09 "Standard Test Method for Water Penetration of Exterior Windows, Skylights, Doors, and Curtain Walls by Cyclic Static Air Pressure Differential".

6. ASTM E2190-10 "Standard Specification for Insulating Glass Unit Performance and Evaluation".
7. ASTM F588-07 "Standard Test Methods for Measuring the Forced Entry Resistance of Window Assemblies, Excluding Glazing Impact".

C. NFRC - National Fenestration Rating Council:

1. NFRC 100-2010 "Procedure for Determining Fenestration Product U Factors".
2. NFRC 102-2010 "Procedure for Measuring the Steady-State Thermal Transmittance of Fenestration Systems".
3. NFRC 500-2010 "Procedure for Determining Fenestration Product Condensation Resistance Values".

D. SGCC - Safety Glazing Certification Council:

1. ANSI Z97.1-04 "American National Standard for Safety Glazing Materials used in Buildings - Safety Performance Specifications and Methods of Test".
2. 16 CFR 1201 "Consumer Product Safety Commission Safety Standard for Architectural Glazing Materials - codified at Title 16, Part 1201 of the Code of Federal Regulations 2011 Edition".

1.4 SUBMITTALS

- A. Submit under provisions of Section 01 33 00.
- B. Product Data: Manufacturer's data sheets on each product to be used, including:
 1. Manufacturer's specifications and test reports or waiver from an AAMA-accredited laboratory.
 2. Preparation instructions and recommendations.
 3. Storage and handling requirements and recommendations.
 4. Installation methods.
- C. Shop Drawings: Window location chart; typical window elevations; details of assemblies and glazing details for units glazed by the window manufacturer.
- D. Selection Samples: For each finish product specified, two complete sets of color chips representing manufacturer's full range of available colors and patterns.
- E. Verification Samples: For each finish product specified, two samples, minimum size 6 inches square, representing actual product, color, and patterns.

1.5 QUALITY ASSURANCE

- A. Installer Qualifications: Skilled craftspeople who have demonstrated a successful history of installing windows for five years.
- B. Product Requirements:
 1. Furnish a valid AAMA "Authorization for Product Certification" or waiver indicating that the

2. Furnish certification indicating conformance to ASTM E 2190-10 on the insulating glass units.
3. Furnish visible, permanent SGCC certification labels indicating conformance to ANSI Z97.1-04 and/or 16 CFR 1201 on tempered glass lites, if included on the project, and laminated glass lites, if included on the project.

C. Mock-up: Provide a mock-up for evaluation of complete installation techniques and application workmanship.

1. Mock-up to be an actual single window bay as designated by the Construction Manager or Architect.
2. Include frame, glazing sealant and trims for representation of a complete installation.
3. Do not proceed with remaining work until workmanship are approved by Architect.
4. Refinish mock-up area as required to produce acceptable work.

1.6 DELIVERY, STORAGE, AND HANDLING

- A. Store products in manufacturer's unopened packaging until ready for installation.
- B. Handle and protect windows and accessories in accordance with AAMA CW-10-04 until project completion.

1.7 PROJECT CONDITIONS

- A. Maintain environmental conditions (temperature, humidity, and ventilation) within limits recommended by manufacturer for optimum results. Do not install products under environmental conditions outside manufacturer's absolute limits.

1.8 WARRANTY

A. Manufacturer's Warranties:

1. Windows: Manufacturer shall warrant for one year against defects in material and workmanship under normal use.
2. Insulating Glass Units: Glass manufacturer shall warrant seal for ten years against visual obstruction from film formation or moisture collection between internal glass surfaces, excluding that caused by glass breakage or abuse.
3. Paint Finish: 70% PVDF 2-coat organic finish conforming to AAMA 2605-11 shall be warranted for twenty years against chipping, peeling, blistering, cracking, chalking, or fading.
4. Project Survey: Installer and manufacturer's representatives shall visit site one year after date of completion; to inspect and recommend maintenance procedures.

PART 2 PRODUCTS

2.1 MANUFACTURERS

- A. Acceptable Manufacturer: Peerless Products, Inc., which is located at: P. O. Box 431 2403 S. Main

St. ; Ft. Scott, KS 66701; Toll Free Tel: 866-420-4000; Tel: 620-223-4610; Fax: 620-224-3107; Email: [requestinfo \(ahare@peerlessproducts.com\)](mailto:requestinfo@peerlessproducts.com); Web: www.peerlessproducts.com

B. TRACO NX-3800 series as manufactured by Kawneer.

C. Graham S6500 series window.

2.2 PROJECTED WINDOW UNITS

A. Product: Peerless G101 Projected and G141Fixed Thermal Aluminum Window.

B. Configuration: Project out, fixed panel.

C. Finish: (70% PVDF 2-coat kynar) with 20 year weathering period warranty. Color to be selected from manufacturer's standard color palette.

D. Construction:

1. Aluminum Extrusions: Extruded by the window manufacturer from commercial quality 6063-T5 alloy; free from defects impairing strength and durability.
2. Frame: Double tubular head, sill, and jambs mitre cut and fastened with two zamac corner gussets per corner; double tubular integral mullion, if required, fastened with two zamac gussets per frame member without penetrating the frame member with fasteners; corners sealed by the window manufacturer with sealant conforming to AAMA 800-10.
3. Vents: Double tubular horizontal and vertical vent rails and stiles mitre cut and fastened with two zamac corner gussets per corner; corners sealed by window manufacturer with sealant conforming to AAMA 800-10.
4. Water Control: Continuous compression gasket to utilize pressure equalization and to allow water to drain by gravity.
5. Window Frame: Extruded aluminum with integral structural thermal break installed by the window manufacturer in the frame and vent members; exterior and interior finishes applied by the window manufacturer; frames and vents assembled by the window manufacturer.
 - a. Frame Depth: 2-1/2 inches (64 mm).
6. Thermal Break: The thermal break separating the exterior and interior aluminum extrusions shall be a mechanical crimp-in-place system utilizing multi-directional glass fiber reinforced polyamide nylon struts with locking mechanical connections to the aluminum extrusions. The thermal break shall not be compromised by hardware or metal fasteners. Old style pour and debridge polyurethane thermal breaks are not permitted.
7. Glazing: Exterior silicone; insulating glass as scheduled; interior Santoprene bulb gasket threaded into aluminum glazing beads; glazed by the window manufacturer.
8. Weatherstrip: Secured in extruded ports; Santoprene bulb seal conforming to AAMA 702-11: single row on the vent bottom rail and double rows on the vent top rail and vent stiles.

E. Performance:

1. Conformance to AP-AW100 when tests are performed on a 60 inches by 36 inches minimum test size with the following test results:
2. Air Infiltration: Not to exceed the standard of maximum 0.1 cfm/square foot when tested per

- ASTM E283-04 at a static air pressure difference of 6.24 psf.
3. Water Penetration: No uncontrolled water leakage when tested per ASTM E331-09 and ASTM E547-09 at a static air pressure difference of 12 psf.
 4. Uniform Deflection: No more than L/175 when tested per ASTM E330-10 at a static air pressure difference of 80 psf.
 5. Uniform Structural Load: No glass breakage or permanent damage to fasteners, and maximum .2% permanent deformation of the span of any frame member when tested per ASTM E330-10 at a static air pressure difference of 120 psf.
 6. Forced-Entry Resistance: Latching devices shall provide reasonable security against forced entry and the test window shall achieve a Level 10 when tested per ASTM F588-07.
- F. Thermal NFRC Simulation: Thermal computer simulation per NFRC 100-2010 on a 60 inches by 36 inches test size glazed with 1 inch insulating made with 1/4 inch soft coat low E coating on surface #2, argon gas in the airspace made with a polymer-coated stainless steel spacer, and 1/4 inch clear glass, with the following test result:
1. Standardized Thermal Transmittance to be maximum 0.397 btu/hr/sq.ft/degree F.
- G. Thermal AAMA Testing: per AAMA 1503-09, on a 59 inches by 24 inches test size glazed with 1 inch insulating glass made with 1/4 inch soft coat low E coating on surface #2, plain air in the airspace made with a polymer-coated stainless steel spacer, and 1/4 inch clear glass, with the following test results:
1. Condensation Resistance Factor: minimum 60 frame CRF and 66 glass CRF.
 2. Thermal Transmittance: maximum 0.51 btu/hr/sq.ft/degree F U value.
- H. Thermal NFRC Testing: per NFRC 102-2010 on a 59 inches by 24 inches test size glazed with 1 inch insulating glass made with 1/4 inch soft coat low E coating on surface #2, plain air in the airspace made with a polymer-coated stainless steel spacer, and 1/4 inch clear glass, with the following test result:
1. Standardized Thermal Transmittance to be maximum 0.47 btu/hr/sq.ft/degree F.
- I. Glazing Schedule:
1. **Type 1 – Gray-Tint Insulating Glass;** Low Emissivity, 1” hermetically sealed assembly consisting of 1/4” tinted glass on the outboard surface, 1/2” air space and 1/4” clear glass on the inboard surface. Temper all glass components where indicated on the drawings and where required by Code. Tinted glazing units shall be equal to praylite PPG Solarban 60 Low-E.
 2. **Type 2 – Obscure Insulating Glass;** Low Emissivity, 1” hermetically sealed assembly consisting of 1/4” tinted glass on the outboard surface, 1/2” air space and 1/4” obscure glass on the inboard surface. Temper all glass components where indicated on the drawings and where required by Code. Tinted glazing units shall be equal to graylite PPG Solarban 60 Low-E.

PART 3 EXECUTION

3.1 EXAMINATION

- A. Do not begin installation until substrates have been properly prepared.

- B. If substrate preparation is the responsibility of another installer, notify Architect of unsatisfactory preparation before proceeding.

3.2 PREPARATION

- A. Prepare openings to be in tolerance, plumb, level, provide for secure anchoring, and in accordance with approved shop drawings.
- B. Prepare surfaces using the methods recommended by the manufacturer for achieving the best result for the substrate under the project conditions.

3.3 INSTALLATION

- A. Install windows in accordance with manufacturer's instructions and approved submittals. Provide required support and securely fasten and set windows plumb, square, and level without twist or bow. Install in proper relationship with adjacent construction.
- B. Apply sealant per sealant manufacturer's recommendations at joints, wipe off excess, and leave exposed sealant surfaces clean and smooth.

3.4 FIELD TESTING

- A. Test installed units in conformance with AAMA 502-11 minimum requirements for air and water infiltration with the window manufacturer, dealer, Contractor, and Owner present.
- B. Select test units as directed by the owner's representative and use an AAMA-accredited laboratory provided by the Owner or Contractor.

3.5 PROTECTION

- A. Protect installed products until completion of project.
- B. Touch-up, repair or replace damaged products before Substantial Completion.

END OF SECTION

**SECTION 08 71 00
DOOR HARDWARE**

PART 1 - GENERAL

1.01 RELATED DOCUMENTS

- A. Drawings and general provisions of Contract, including General and Supplementary Conditions of Division 1 Specification Sections, apply to this Section.

1.02 SUMMARY

- A. This Section includes items known commercially as finish or door hardware that are required for swing, sliding, and folding doors, except special types of unique hardware specified in the same sections as the doors and door frames on which they are installed.

- B. This Section includes the following, but is not necessarily limited to:

- 1. Door Hardware.
- 2. Storefront and Entrance door hardware.
- 3. Gate Hardware.
- 4. Thresholds, gasketing and weather-stripping.
- 5. Door silencers or mutes.

- C. Related Sections: The following sections are noted as containing requirements that relate to this Section, but may not be limited to this listing.

- 1. Section 08 11 00: Metal Doors and Frames.
- 2. Section 08 14 16: Flush Wood Doors.

1.03 REFERENCES

- A. 2010 California Building Code, CCR, Title 24.
- B. BHMA - Builders' Hardware Manufacturers Association.
- C. CCR - California Code of Regulations, Title 24, Part 2, California State Accessibility Standards.
- D. DHI - Door and Hardware Institute.
- E. NFPA - National Fire Protection Association.
 - 1. NFPA 80 - Fire Doors and Windows
 - 2. NFPA 101 - Life Safety Code
 - 3. NFPA 105 - Smoke and Draft Control Door Assemblies
- F. UL - Underwriters Laboratories.
 - 1. UL 10C - Fire Tests of Door Assemblies
 - 2. UL 305 - Panic Hardware
- G. WHI - Warnock Hersey Incorporated
- H. SDI - Steel Door Institute

1.04 SUBMITTALS & SUBSTITUTIONS

- A. General: Submit in accordance with Conditions of the Contract and Division 1 Specification sections.
- B. Submit product data (catalog cuts) including manufacturers' technical product information for each item of door hardware, installation instructions, maintenance of operating parts and finish, and other information necessary to show compliance with requirements.
- C. Submit six (6) copies of schedule organized vertically into "Hardware Sets" with index of doors and headings, indicating complete designations of every item required for each door or opening. Include following information:
 - 1. Include a Cover Sheet with;
 - a. Job Name, location, telephone number.
 - b. Architects name, location and telephone number.
 - c. Contractors name, location, telephone number and job number.
 - d. Suppliers name, location, telephone number and job number.
 - e. Hardware consultant's name, location and telephone number.
 - 2. Job Index information included;
 - a. Numerical door number index including; door number, hardware heading number and page number.
 - b. Complete keying information (referred to DHI hand-book "Keying Systems and Nomenclature"). Provision should be made in the schedule to provide keying information when available; if it is not available at the time the preliminary schedule is submitted.
 - c. Manufacturers' names and abbreviations for all materials.
 - d. Explanation of abbreviations, symbols, and codes used in the schedule.
 - e. Mounting locations for hardware.
 - f. Clarification statements or questions.
 - g. Catalog cuts and manufacturer's technical data and instructions.
- D. Make substitution requests in accordance with Division 1. Substitution requests must be made prior to bid date. Include product data and indicate benefit to the project. Furnish samples of any proposed substitution.
- E. Wiring Diagrams: Provide product data and wiring and riser diagrams for all electrical products listed in the Hardware Schedule portion of this section.
- F. Keying Schedule: Submit separate detailed schedule indicating clearly how the Owner's final instructions on keying of locks has been fulfilled.
- G. Templates for doors, frames, and other work specified to be factory prepared for the installation of door hardware. Check shop drawings of other work to confirm that adequate provisions are made for locating and installing door hardware to comply with indicated requirements.
- H. Furnish as-built/as-installed schedule with close-out documents, including keying schedule, wiring/riser diagrams, manufacturers' installation, adjustment and maintenance information.
- I. Fire Door Assemblies: A written record of inspection with confirmation of proper operation of all swinging fire rated openings shall be given to the Owner at the time the building is approved for occupancy.

1.05 QUALITY ASSURANCE

- A. Obtain each type of hardware (latch and lock sets, hinges, closers, exit devices, etc.) from a single manufacturer.
- B. Supplier Qualifications: A recognized architectural door hardware supplier, with warehousing facilities in the project's vicinity, that has a record of successful in-service performance for supplying door hardware similar in quantity, type, and quality to that indicated for this project and that employs an experienced architectural hardware consultant (AHC) who is available to Owner, Architect, and Contractor, at reasonable times during the course of the Work, for consultation.
 - 1. Responsible for detailing, scheduling and ordering of finish hardware.
 - 2. Meet with Owner to finalize keying requirements and to obtain final instructions in writing.
 - 3. Stock parts for products supplied and are capable of repairing and replacing hardware items found defective within warranty periods.
- C. Hardware Installer: Company specializing in the installation of commercial door hardware with five years documented experience.
- D. Fire-Rated Openings: Provide door hardware for fire-rated openings that complies with NFPA Standard No. 80 and requirements of authorities having jurisdiction. Provide only items of door hardware that are listed and tested by UL or Warnock Hersey for given type/size opening and degree of label. Provide proper latching hardware, door closers, approved-bearing hinges and seals whether listed in the Hardware Schedule or not.
 - 1. Where emergency exit devices are required on fire-rated doors, (with supplementary marking on doors' UL labels indicating "Fire Door to be Equipped with Fire Exit Hardware") provide UL label on exit devices indicating "Fire Exit Hardware".
- E. Exit Doors: Operable from inside with single motion without the use of a key or special knowledge or effort.

1.06 DELIVERY, STORAGE AND HANDLING

- A. Coordinate delivery of packaged hardware items to the appropriate locations (shop or field) for installation.
- B. Hardware items shall be individually packaged in manufacturers' original containers, complete with proper fasteners. Clearly mark packages on outside to indicate contents and locations in hardware schedule and in work.
- C. Provide locked storage area for hardware, protect from moisture, sunlight, paint, chemicals, etc.
- D. Inventory door hardware jointly with representatives of hardware supplier and hardware installer until each is satisfied that count is correct.

1.07 WARRANTY

- A. Provide warranties of respective manufacturers' regular terms of sale from day of final acceptance as follows:
 - 1. Locksets: Seven (7) years.
 - 2. Electronic or VIP Locks: One (1) year.
 - 3. Closers: Ten (10) years, except electronic closers shall be two (2) years.
 - 4. Exit devices: Three (3) years.
 - 5. All other hardware: Two (2) years.

1.08 MAINTENANCE

- A. Maintenance Tools and Instructions: Furnish a complete set of specialized tools and maintenance instructions as needed for Owner's continued adjustment, maintenance, and removal and replacement of door hardware.

1.09 PRE-INSTALLATION CONFERENCE

- A. Convene a pre-installation conference at least one week prior to beginning work of this section.
- B. Attendance: Architect, Construction Manager, Contractor, Security Contractor, Hardware Supplier, Installer, Key District Personnel, and Project Inspector.
- C. Agenda: Review hardware schedule, products, installation procedures and coordination required with related work. Review District's keying standards.

PART 2 - PRODUCTS

2.01 MANUFACTURERS

	<u>Item</u>	<u>Manufacturer</u>	<u>Acceptable Substitutes</u>
A.	Hinges	By Door Manuf.	Ives, Hager, Stanley, McKinney
B.	Locks, Latches & Cylinders	Schlage	None
C.	Exit Devices	Von Duprin	None
D.	Closers	LCN	None
E.	Push, Pulls & Protection Plates	Ives	Trimco, BBW, Quality
F.	Flush Bolts	Ives	Trimco, BBW, Quality
G.	Dust Proof Strikes	Ives	Trimco, BBW, Quality
H.	Coordinators	Ives	Trimco, BBW, Quality
I.	Stops	Ives	Trimco, BBW, Quality
J.	Overhead Stops	Glynn-Johnson	None
K.	Thresholds	National Guard	Pemko, Zero
L.	Seals & Bottoms	National Guard	Pemko, Zero

2.02 MATERIALS

- A. Hinges: Exterior out-swinging door butts shall be non-ferrous material and shall have stainless steel hinge pins. All doors to have non-rising pins.
 - 1. Hinges shall be sized in accordance with the following:
 - a. Height:

- 1) Doors up to 41" wide: 4-1/2" inches.
 - 2) Doors 42" to 48" wide: 5 inches.
 - b. Width: Sufficient to clear frame and trim when door swings 180 degrees.
 - c. Number of Hinges: Furnish 3 hinges per leaf to 7'-5" in height. Add one for each additional 2 feet in height.
2. Furnish non-removable pins (NRP) at all exterior out-swing doors and interior key lock doors with reverse bevels..
- B. Pivots: High strength forgings and castings with precision bearings for smooth operation. Positive locking vertical adjustment mechanism to allow installer to precisely position the door and balance the load.
- C. Continuous Hinges: As manufactured by Ives, an Ingersoll-Rand Company. UL rated as required.
- D. Heavy Duty Cylindrical Locks and Latches: Schlage "ND" Series as scheduled with "Rhodes" design, fastened with through-bolts and threaded chassis hubs.
1. Locksets to comply with ANSI A156.2, Series 4000, Grade 1; tested to exceed 3,000,000 cycles. Locksets shall meet ANSI A117.1, Accessible Code.
 2. Chassis: One piece modular assembly and multi-functional allowing function interchange without disassembly of lockset.
 3. Spindle shall be deep-draw manufactured not stamped. Spindle and spring cage to be one-piece integrated assembly.
 4. Anti-rotation plate to be interlocking to the lock chassis. Lock design utilizing bit-tabs are not acceptable.
 5. Lever Trim: Accessible design, bi-directional, independent assemblies.
 6. Locks shall be of such construction that when locked, the door may be opened from within by using lever and without the use of a key or special knowledge.
 7. Thru-bolts to secure anti-rotation plate without sheer line. Fully threaded thru-bolts are not acceptable.
 8. Spring cage to have double compression springs. Manufacturers utilizing torsion springs are not acceptable.
 9. Latchbolt to be steel with minimum 1/2" throw deadlatch on keyed and exterior functions; 3/4" throw anti-friction latchbolt on pairs of doors.
 10. Strikes: ANSI curved lip, 1-1/4" x 4-7/8", with 1" deep dust box (K510-066). Lips shall be of sufficient length to clear trim and protect clothing.
- E. Exit devices: Von Duprin as scheduled.
1. Provide certificate by independent testing laboratory that device has completed over 1,000,000 cycles and can still meet ANSI/BHMA A156.3 - 2001 standards.
 2. All internal parts shall be of cold-rolled steel with zinc dichromate coating.
 3. Mechanism case shall have an average thickness of .140".
 4. Compression spring engineering.
 5. Non-handed basic device design with center case interchangeable with all functions.
 6. All devices shall have quiet return fluid dampeners.
 7. All latchbolts shall be deadlocking with 3/4" throw and have a self-lubricating coating to reduce friction and wear.
 8. Device shall bear UL label for fire and or panic as may be required.
 9. All surface strikes shall be roller type and utilize a plate underneath to prevent movement.
 10. Lever Trim: "Breakaway" design, forged brass or bronze escutcheon with a minimum of .130" thickness, match lockset lever design.
 11. Removable Mullions: Removable with single turn of building key. Securely reinstalled without need for key.
 12. Furnish glass bead kits for vision lites where required.

13. All Exit Devices to be sex-bolted to the doors.
 14. Panic Hardware shall comply with CBC Section 1008.1.10 and shall be mounted between 34" and 44" above the finished floor surface. The unlatching force shall not exceed 15 lbs. applied in the direction of travel.
 15. Provide Cylinder Dogging (CD)
- F. Closers: LCN as scheduled. Place closers inside building, stairs, room, etc.
1. Door closer cylinders shall be of high strength cast iron construction with double heat treated pinion shaft to provide low wear operating capabilities of internal parts throughout the life of the installation. All door closers shall be tested to ANSI/BHMA A156.4 test requirements by a BHMA certified testing laboratory. A written certification showing successful completion of a minimum of 10,000,000 cycles must be provided.
 2. All door closers shall be fully hydraulic and have full rack and pinion action with a shaft diameter of a minimum of 11/16 inch and piston diameter of 1 inch to ensure longevity and durability under all closer applications.
 3. All parallel arm closers shall incorporate one piece solid forged steel arms with bronze bushings. 1-9/16" steel stud shoulder bolts, shall be incorporated in regular arms, hold-open arms, arms with hold open and stop built in. All other closers to have forged steel main arms for strength, durability, and aesthetics for versatility of trim accommodation, high strength and long life.
 4. All parallel arm closers so detailed shall provide advanced backcheck for doors subject to severe abuse or extreme wind conditions. This advanced backcheck shall be located to begin cushioning the opening swing of the door at approximately 45 degrees. The intensity of the backcheck shall be fully adjustable by tamper resistant non-critical screw valve.
 5. Closers shall be installed to permit doors to swing 180 degrees.
 6. All closers shall utilize a stable fluid withstanding temperature range of 120 degrees F. to -30 degrees F. without requiring seasonal adjustment of closer speed to properly close the door.
 7. Provide the manufactures drop plates, brackets and spacers as required at narrow head rails and special frame conditions. NO wood plates or spacers will be allowed.
 8. Maximum effort to operate closers shall not exceed 5 lbs., such pull or push effort being applied at right angles to hinged doors. Compensating devices or automatic door operators may be utilized to meet the above standards. When fire doors are required, the maximum effort to operate the closer may be increased but shall not exceed 15 lbs. when specifically approved by fire marshal. All closers shall be adjusted to operate with the minimum amount of opening force and still close and latch the door. These forces do not apply to the force required to retract latch bolts or disengage other devices that hold the door in a closed position. Door shall take at least 3 seconds to move from an open position of 70 degrees to a point of 3 inches from the latch jamb. Reference CBC Sections 1133B.2.5 & 1133B2.5.1.
 9. Provide sex-bolted or through bolt mounting for all door closers.
- G. Flush Bolts & Dust Proof Strikes: Automatic Flush Bolts shall be of the low operating force design. Utilize the top bolt only model for interior doors where applicable and as permitted by testing procedures.
1. Manual flush bolts only permitted on storage or mechanical openings as scheduled.
 2. Provide dust proof strikes at openings using bottom bolts.
- H. Door Stops:
1. Unless otherwise noted in Hardware Sets, provide floor type with appropriate fasteners. Where floor type cannot be used, provide wall type. If neither can be used, provide overhead type.
 2. Do not install floor stops more than four (4) inches from the face of the wall or partition (CBC Section 1133B.8.6).
 3. Overhead stops shall be made of stainless steel and non-plastic mechanisms and finished metal end caps. Field-changeable hold-open, friction and stop-only functions.

- I. Protection Plates: Fabricate either kick, armor, or mop plates with four beveled edges. Provide kick plates 10" high and 2" LDW. Sizes of armor and mop plates shall be listed in the Hardware Schedule. Furnish with machine or wood screws of bronze or stainless to match other hardware.
- J. Thresholds: As Scheduled and per details.
 - 1. Thresholds shall not exceed 1/2" in height, with a beveled surface of 1:2 maximum slope.
 - 2. Set thresholds in a full bed of butyl-rubber or polyisobutylene mastic sealant complying with requirements in Division 7 "Thermal and Moisture Protection".
 - 3. Use 1/4" fasteners, red-head flat-head sleeve anchors (SS/FHSL).
 - 4. Thresholds shall comply with CBC Section 1133B.2.4.1.
- K. Seals: Provide silicone gasket at all rated and exterior doors.
 - 1. Fire-rated Doors, Resilient Seals: UL10C Classified, Category "J" listed seals complying with NFPA 80 & NFPA 252 Standards. Coordinate with selected door manufacturers' and selected frame manufacturers' requirements.
 - 2. Fire-rated Doors, Intumescent Seals: Furnished by selected door manufacturer. Category "G" furnish fire-labeled opening assembly complete and in full compliance with NFPA 252. Where required, intumescent seals vary in requirement by door type and door manufacture -- careful coordination required.
 - 3. Smoke & Draft Control Doors, Provide Category "H" listed seals complying with NFPA 105 for use on "S" labeled Positive Pressure door assemblies.
- L. Door Shoes & Door Top Caps: Provide door shoes at all exterior wood doors and top caps at all exterior out-swing doors.
- M. Silencers: Furnish silencers for interior hollow metal frames, 3 for single doors, 2 for pairs of doors. Omit where sound or light seals occurs, or for fire-resistive-rated door assemblies.

2.03 KEYING

- A. Furnish a Proprietary Schlage masterkey system as directed by the owner or architect. Key system to be designated and combined by the Schlage Master Key Department even if pinned by the Authorized Key Center, Authorized Security Center or a local authorized commercial dealer.
- B. A detailed keying schedule is to be prepared by the owner and/or architect in consultation with a representative of Ingersoll Rand Security Consultants or an Authorized Key Center or Authorized Security Center. Each keyed cylinder on every keyed lock is to be listed separately showing the door #, key group (in BHMA terminology), cylinder type, finish and location on the door.
- I. Furnish mechanical keys as follows:
 - 1. Furnish 2 cut change keys for each different change key code.
 - 2. Furnish 1 uncut key blank for each change key code.
 - 3. Furnish 6 cut masterkeys for each different masterkey set.
 - 4. Furnish 3 uncut key blanks for each masterkey set.
 - 5. Furnish 2 cut control keys cut to the top masterkey for permanent I/C cylinders.
 - 6. Furnish 1 cut control key cut to each SKD combination.

2.04 FINISHES

- A. Generally to be satin chrome US26D (626 on bronze and 652 on steel) unless otherwise noted.

- B. Furnish push plates, pull plates and kick or armor plates in satin stainless steel US32D (630) unless otherwise noted.
- C. Door closers shall be powder-coated to match other hardware, unless otherwise noted.
- D. Aluminum items to be finished anodized aluminum except thresholds which can be furnished as standard mill finish.

2.05 FASTENERS

- A. Screws for strikes, faceplates and similar items shall be flat head, countersunk type, provide machine screws for metal and standard wood screws for wood.
- B. Screws for butt hinges shall be flathead, countersunk, full-thread type.
- C. Fastening of closer bases or closer shoes to doors shall be by means of sex bolts and spray painted to match closer finish.
- D. Provide expansion anchors for attaching hardware items to concrete or masonry.
- E. All exposed fasteners shall have a phillips head.
- F. Finish of exposed screws to match surface finish of hardware or other adjacent work.
- G. All Exit Devices and Lock Protectors shall be fastened to the door by the means of sex bolts or through bolts.

PART 3 - EXECUTION

3.01 INSPECTION

- A. Verify that doors and frames are square and plumb and ready to receive work and dimensions are as instructed by the manufacturer.
- B. Beginning of installation means acceptance of existing conditions.

3.02 INSTALLATION

- A. Install hardware in accordance with manufacturer's instructions and requirements of DHI.
- B. Use the templates provided by hardware item manufacturer.
- C. Mounting heights for hardware shall be as recommended by the Door and Hardware Institute. Operating hardware will to be located between 34" and 44" AFF.
- D. Set units level, plumb and true to line and location. Adjust and reinforce the attachment substrate as necessary for proper installation and operation.
- E. Drill and countersink units that are not factory-prepared for anchorage fasteners. Space fasteners and anchors in accordance with industry standards.
- F. Set thresholds for exterior doors in full bed of butyl-rubber sealant.
- G. If hand of door is changed during construction, make necessary changes in hardware at no additional cost.

3.03 ADJUST AND CLEAN

- A. Adjust and check each operating item of hardware and each door, to ensure proper operation or function of every unit. Replace units which cannot be adjusted to operate freely and smoothly as intended for the application made.
- B. Clean adjacent surface soiled by hardware installation.
- C. Final Adjustment: Wherever hardware installation is made more than one month prior to acceptance or occupancy, return to that work area and make final check and adjustment of all hardware items in such space or area. Clean operating items as necessary to restore proper function and finish of hardware and doors. Adjust door control devices to compensate for final operation of heating and ventilating equipment.
- D. Instruct Owner's Personnel in proper adjustment and maintenance of hardware finishes, during the final adjustment of hardware.
- E. Continued Maintenance Service: Approximately six months after the completion of the project, the Contractor accompanied by the Architectural Hardware Consultant, shall return to the project and re-adjust every item of hardware to restore proper functions of doors and hardware. Consult with and instruct Owner's personnel in recommended additions to the maintenance procedures. Replace hardware items which have deteriorated or failed due to faulty design, materials or installation of hardware units. Prepare a written report of current and predictable problems (of substantial nature) in the performance of the hardware.

3.04 HARDWARE LOCATIONS

- A. Conform to CCR, Title 24, Part 2, and ADAAG for positioning requirements for the disabled.

3.05 FIELD QUALITY CONTROL

- A. Architectural Hardware Consultant (AHC) to inspect installation and certify that hardware and it's installation have been furnished and installed in accordance with manufacturer's instructions and as specified herein.
- B. Fire-Rated Assemblies: Upon completion of the installation, all fire door assemblies shall be inspected to confirm proper operation of the closing device and latching device and that it meets all criteria of a fire door assembly per NFPA 80 2007 Edition. A written record shall be maintained and given to the owner to be made available to the AHJ. The inspection of the swinging fire doors, with builders hardware devices, shall be performed by individuals with knowledge and understanding of the operating components of the type of door being testing.

3.06 SCHEDULE

- A. The items listed in the following schedule shall conform to the requirements of the foregoing specifications.
- B. The Door Schedule on the Drawings indicates which hardware set is used with each door.

Manufacturers Abbreviations (Mfr.)

ADA	=	Adams Rite Mfg.	Aluminum Door Hardware
GLY	=	Glynn-Johnson Corporation	Overhead Door Stops
HAG	=	Hager	Hinges
IVE	=	Ives	Hinges, Pivots, Bolts, Coordinators, Dust Proof

LCN =	LCN	Strikes, Push Pull & Kick Plates, Door Stops & Silencers
NGP =	National Guard Products	Door Closers
PEM =	Pemko	Thresholds, Gasketing & Weather-stripping
SCE =	Schlage Electronics	Thresholds, Gasketing & Weather-stripping
SCH =	Schlage Lock Company	Electronic Door Components
SEL =	Select Products	Locks, Latches & Cylinders
TRI =	Trimco	Continuous Hinges
VON =	Von Duprin	ADA Pocket Door Pulls & Flush Pulls
		Exit Devices

HARDWARE LIST

Hardware Group No. 01 – (existing rated out-swinging interior door in existing frame)

<i>Item:</i>	<i>Manufacturer:</i>	<i>Quantity:</i>	<i>Model No.:</i>	<i>Finish:</i>	<i>Notes:</i>
Exit Device	Von Duprin	1	99L-2x994L	626	
Cylinder	Schlage	1	I/C #20-757	626	
Closer	LCN	1	4041	689	
Hinge	Hager	3	BB1168 x NRP	626	
Stop	Ives	1	FS18S	rubber	
Smoke Gasket	Pemko	1	HSS2000xS88	BL	
Kickplate	Ives	2	8400	626	

Hardware Group No. 02 – (existing OR new rated out-swinging interior door in existing OR new frame)

<i>Item:</i>	<i>Manufacturer:</i>	<i>Quantity:</i>	<i>Model No.:</i>	<i>Finish:</i>	<i>Notes:</i>
Lockset	Schlage	1	ND70PD	626	rhodes lvr
Lockset Protector	Trimco	1	1082-6	SS	
Cylinder	Schlage – Primus	1	I/C #20-757	626	
Closer	LCN	1	4041	689	
Hinge	Hager	3	BB1168 x NRP	626	
Stop	Ives	1	FS18S	rubber	
Smoke Gasket	Pemko	1	HSS2000xS88	BL	
Kickplate	Ives	2	8400	626	

Hardware Group No. 03 – (existing rated out-swinging interior door in existing frame)

<i>Item:</i>	<i>Manufacturer:</i>	<i>Quantity:</i>	<i>Model No.:</i>	<i>Finish:</i>	<i>Notes:</i>
Closer	LCN	1	4041	689	
Hinge	Hager	3	BB1168 x NRP	626	
Stop	Ives	1	FS18S	rubber	
Smoke Gasket	Pemko	1	HSS2000xS88	BL	
Kickplate	Ives	2	8400	626	

*Remove and reinstall panic hardware.

Hardware Group No. 04 – (existing OR new non-rated out-swinging exterior door in existing OR new frame)

<i>Item:</i>	<i>Manufacturer:</i>	<i>Quantity:</i>	<i>Model No.:</i>	<i>Finish:</i>	<i>Notes:</i>
Exit Device	Von Duprin	1	99L-2x994L	626	
Cylinder	Schlage	1	I/C #20-757	626	
Closer	LCN	1	4041	689	
Hinge	Hager	3	BB1168 x NRP	626	
Stop	Ives	1	FS18S	rubber	

Kickplate	Ives	1	8400	626
Weather-strip	Pemko	1	45041CNB	mill
Door sweep	Pemko	1	3452ANB	mill
Threshold	Pemko	1	2727A	mill
Overhead Drip	Pemko	1	346C	clear anodized

Hardware Group No. 05 – (existing non-rated out-swinging interior door in existing frame)

<i>Item:</i>	<i>Manufacturer:</i>	<i>Quantity:</i>	<i>Model No.:</i>	<i>Finish:</i>	<i>Notes:</i>
Lockset	Schlage	1	ND10S	626	rhodes lvr
Closer	LCN	1	4041	689	
Hinge	Hager	3	BB1168 x NRP	626	
Stop	Ives	1	FS18S	rubber	
Kickplate	Ives	2	8400	626	

Hardware Group No. 06 – (existing non-rated out-swinging exterior door in existing frame)

<i>Item:</i>	<i>Manufacturer:</i>	<i>Quantity:</i>	<i>Model No.:</i>	<i>Finish:</i>	<i>Notes:</i>
Lockset	Schlage	1	ND70PD	626	rhodes lvr
Lockset Protector	Trimco	1	1082-6	SS	
Cylinder	Schlage – Primus	1	I/C #20-757	626	
Closer	LCN	1	4041	689	
Hinge	Hager	3	BB1168 x NRP	626	
Stop	Ives	1	FS18S	rubber	
Kickplate	Ives	1	8400	626	
Weather-strip	Pemko	1	45041CNB	mill	
Door sweep	Pemko	1	3452ANB	mill	
Threshold	Pemko	1	2727A	mill	
Overhead Drip	Pemko	1	346C	clear anodized	

Hardware Group No. 07 – (new out-swinging exterior gate)

<i>Item:</i>	<i>Manufacturer:</i>	<i>Quantity:</i>	<i>Model No.:</i>	<i>Finish:</i>	<i>Notes:</i>
Exit Device	Von Duprin	1	CD98NL-OP	626	
Cylinder	Schlage – Primus	1	I/C #20-757	626	
Cylinder	Schlage – Primus	1	I/C #20-7000 1-1/4 x XO 11949	626	
Exterior Pull	Ives	1	VR910-NL	US32D	
Hinge	per spec	2		galv	
Kickplate	custom	1			see dwgs

Hardware Group No. 08 – (new in-swinging exterior gate)

<i>Item:</i>	<i>Manufacturer:</i>	<i>Quantity:</i>	<i>Model No.:</i>	<i>Finish:</i>	<i>Notes:</i>
Lockset	Schlage	1	ND10S	626	rhodes lvr
Hinge	per spec	2		galv	
Kickplate	custom	1			see dwgs

END OF SECTION

**SECTION 09 21 16
GYPSUM BOARD ASSEMBLIES**

The General Conditions, Supplementary Conditions and Division 1 General Requirements are hereby made a part of this Section as fully as if repeated herein.

PART 1 - GENERAL

1.01 DESCRIPTION:

A. Work Included: Gypsum wallboard and backerboard systems as shown on the Drawings or specified herein. This Section also includes:

1. Installation of access doors in finished gypsum wallboard surfaces.
2. Caulking and sealants related to gypsum wallboard systems (sound retardant construction).
3. Cementing and taping.

B. Related Work Specified Elsewhere:

1. Rough Carpentry 06 10 00.
2. Plastic Laminate Clad Architectural Cabinets 06 41 16.
3. Thermal Insulation 07 21 00.
4. Aluminum Windows 08 51 13.
5. Painting 09 91 00.
6. Vinyl-Coated Fabric Wall Coverings 09 92 16.
7. Mechanical and Electrical Sections.

1.02 REFERENCES, CODES AND STANDARDS: Work shall conform to the applicable requirements therein except as otherwise specified herein or shown on the Drawings. Nothing in the Drawings or these Specifications shall be construed as permitting work which is contrary to code requirements.

1.03 SUBMITTALS: Comply with requirements of Shop Drawings, Product Data and Samples Section 01 33 00.

A. Product data, material handling and installation instructions for all components specified herein.

1.04 DELIVERY, HANDLING AND STORAGE:

A. Deliver materials in original packages, containers or bundles bearing brand and manufacturer's names.

B. Store materials in protected dry storage areas. Neatly stack in flat position with suitable stickers to prevent sagging and contact with concrete slabs.

PART 2 - PRODUCTS

2.01 MATERIALS:

- A. Gypsum Wallboard: ASTM C 5/8" thickness unless otherwise noted. Pieces to be 4 ft. wide, lengths as required for minimum of end joints. 5/8" type "X" at fire rated assemblies. Tapered edge for finish surfaces butt edge for concealed surfaces. Water resistant where noted.
- B. Metal Edge Trim: USG 200-A, National Gypsum No. 100, or equivalent, where board edge is exposed; where edge is not exposed, USG 200-B, National Gypsum No. 00, or equivalent, may be used. Corner bead to be USG "Dur-A-Bead, 1-1/4" x 1-1/4" or National Gypsum Wallboard corner bead 1 1/8" x 1 1/8".
- C. Fasteners:
 - 1. Wood Framing - Non-Fire-Rated: Type 'W' Drywall Screws 1 1/4" Drywall Screws for 5/8" board or as recommended by gypsum wallboard manufacturer.
 - 2. Wood Framing - Fire- Rated: 1 1/4" Drywall Screws spaced per manufacturer's assembly approvals or as recommended by wallboard manufacturer.
 - 3. Screw sizes given are for material applied directly to framing; where material is applied over backing, increase screw size for minimum 5/8" penetration in bearing.
 - 4. Conform to CBC.
- D. Tape and Cement: As recommended by wallboard manufacturer and meeting ASTM C 475.

PART 3 - EXECUTION

3.01 CONDITION OF SURFACES: Inspect surfaces, backing, structural systems, etc., to receive wallboard, and report any discrepancies. Starting work implies acceptance of existing conditions.

3.02 COORDINATION:

- A. Coordinate with other trades for provisions for insulation, blocking, backing, special anchors, etc., and ensure that such items are properly installed and located prior to installing wall finish.
- B. Coordinate with trades responsible for furnishing access doors with exact locations subject to Architect's approval.

3.03 INSTALLATION:

- A. Erect gypsum wallboard systems in accord with applicable requirements of References, Standards and Codes Article, referenced manufacturer's specifications and governing codes. Code and manufacturer's specifications shall govern in event of conflict with Gypsum Association Standards.
- B. Install wallboard plumb, level, and/or plane, applied vertically or horizontally with vertical edges and ends on bearing except that wallboard applied over sound deadening board

shall be applied vertically only. Where board is applied horizontally, "rippers", if required, shall be placed so that the cut edge is at the ceiling or floor; cut edges and ends will not be acceptable within the field of the wallboard. Properly space fastenings as per manufacturer's specifications and code requirements, with heads driven slightly below surface for proper cementing, but without breaking paper covering. Loosely butt all joints to be taped; firmly butt concealed joints to be left untreated. Stagger end joints and joints in finish material 12" (min.) with those in backing. Joints on opposite sides of partition shall occur on different studs. Install backing for finish material to present no surface imperfections in applied finish. Make holes and cutouts by sawing or by such method as will not fracture core or tear covering and with such accuracy that plates, escutcheons, trim, etc. will cover edges. Clearance for cutouts in partitions shall not exceed 1/4".

- C. Caulking (Sound Control): Caulk should insulate construction as indicated on Drawings. In addition, caulk penetrations of sound insulated construction such as conduits, pipes, ducts, registers, etc., so that such openings are sealed tight against passage of airborne sound. Holes smaller than 1" but too large to caulk shall be packed with glass fiber, sealed over with 1/16" thick sheet lead and then caulked airtight. Seal the backs of electrical boxes in sound insulated construction airtight using specified resilient sealer pads. All such caulking and sealing shall be concealed where possible; where caulking must remain exposed, use skinning type material and neatly tool.
- D. Install metal edge trim at exposed edges and ends and all untrimmed joints between wallboard finish and other material. Where edge trim is required at wallboard edge, and headers, studs, sill or other backing are not available for positive fastening of trim, apply trim to board with contact type of adhesive.

3.04 TAPING AND FINISHING:

- A. Environmental conditions:

Control heating and ventilation during finishing operations to ensure the maintenance of 55 degree F. minimum temperature.

- B. First coat:

1. Spread compound evenly over all joints, using suitable tools designed for the purpose.
2. Fill all joint recesses and metal trim.
3. Center the reinforcing tape on the joint and press into the fresh compound, wiping down with sufficient pressure to remove excess compound but leaving sufficient compound under the tape for proper bond.
4. Feather all edges and leave the surface free from blisters and tape wrinkles.
5. Apply compound to all fastener recesses, leaving flush with the adjacent surfaces.
6. Fold reinforcing tape along its centerline and apply to all interior angles, following the same procedure as for joints.

- C. Second coat:

1. Lightly sand the dry compound with fine sandpaper to remove all irregularities.

2. Apply a second coat of compound to all joints, feathering approximately three inches beyond edges of tape.
3. Apply second coat to all fastener recesses; allow to dry.

D. Third coat:

1. Lightly sand the dry compound with fine sandpaper to remove all irregularities.
2. Apply final skim coat, feathering out approximately two inches beyond second coat.
3. Third coat all fastener recesses and metal trim and all interior angles; allow to dry.

E. "Smooth" finish:

1. Where smooth finish is called for on the Drawings, and where no other finish is called for on the Drawings, carefully sand the third coat to a uniformly smooth surface completely free from irregularities visible to the unaided eye at a distance of five feet.
2. In existing work – match existing finish.

3.05 GYPSUM DRYWALL; UNDER VINYL COVERED TACKBOARD AND ACOUSTICAL TREATMENT PANELS:

Apply only the "First Coat" outlined under 3.04, B on 5/8 gypsum board under all vinyl covered tackboard and Acoustical Treatment panels.

3.06 CLEANING UP:

Do not allow the accumulation of scraps and debris arising from the work of this Section but maintain the premises in a neat and orderly condition at all times; in the event of spilling or splashing compound onto other surfaces, immediately remove the spilled or splashed material and all trace of the residue to the approval of the Architect.

END OF SECTION

**SECTION 09 22 36
LATH**

The General Conditions, Supplementary Conditions and Division 1 General Requirements are hereby made a part of this Section as fully as if repeated herein.

PART 1 - GENERAL

1.01 DESCRIPTION:

A. Work Included: All lathing work required for the project including:

1. Suspension and furring systems for plaster surfaces.

B. Related Work Specified Elsewhere:

1. Section 07 21 00 Thermal Insulation.

2. Section 09 24 00 Cement Plastering.

3. Section 09 91 00 Painting.

1.02 REFERENCES, CODES AND STANDARDS: The following references, codes and standards are hereby made a part of this Section and all lathing work shall conform to the applicable requirements therein except as otherwise specified herein or shown on the Drawings. Nothing in the Drawings or these Specifications shall be construed as permitting work which is contrary to code requirements.

A. "Specifications for Metal Lathing and Furring", and "Technical Bulletins", all published by Metal Lath/Steel Framing Association, latest editions.

B. "Reference Specifications for Lathing, Furring and Plastering in California", published by California Lathing and Plastering Contractors' Association, Inc., latest edition.

C. California Building Code.

1.03 FIRE-RATED ASSEMBLIES: All fire-rated plaster assemblies including materials and methods of application used, shall be approved by the Building Code.

1.04 DELIVERY AND STORAGE: Deliver materials in original packages, bundles, or rolls as applies, all properly labeled or identified as to contents and manufacturer. Protect metal items from rusting.

PART 2 - PRODUCTS

2.01 MATERIAL:

A. Suspension and Furring Channels: Cold rolled, shop primed, with following minimum weights per 1000 lin. ft.:

$\frac{3}{4}$ " 300 lb.

1-1/2" 475 lb.

- B. Expanded Metal Lath: Bostwick, Milcor, National Gypsum Co., USG, Western, or approved equal, and conforming to Fed. Spec. QQ-L-101.
1. Expanded Diamond Mesh: 3.4# diamond steel mesh, coated with rust inhibitive paint for interior applications and galvanized for exterior use.
 2. Flat Rib Lath: 3.4# flat rib steel mesh, coated with rust inhibitive paint for interior applications and galvanized for exterior use.
 3. 3/8" Rib Lath: 3.4# herringbone steel mesh, coated with rust inhibitive paint for interior applications and galvanized for exterior use.
- C. Paper Backing: Grade "D", 60 min. Waterproof paper per CBC Standard or approved equal – 2 layers minimum over solid sheathing.
- D. Wire Lath (Stucco Netting): Self-furring, galvanized welded wire fabric, 1-1/2" mesh, 16x16 ga. Keystone "Keymesh", or approved equal self-furring, galvanized woven wire, 1-1/2" x 17 ga. Mesh with 18 ga. Horizontal line wires at 6" c-c and Grade "D" waterproof paper backing. Provide two (2) layers of Grade "D" paper over solid sheathing. Grade "D" paper shall be 60 minute. Lath/fabric shall furr out from vertical supports not less than 1/4" except as noted in Table 25-B, Footnote 2 of CBC.
- E. Accessories:
1. Wire: Fed. Spec. QQ-W-462, Class 1, galvanized and annealed steel.
 - a. Hangers: As per recommendations of listed References, Codes and Standards documents for runner spans and spacings used (in general, 8 gage).
 - b. Tie wire not otherwise specified: 18 ga. or heavier.
 - c. Tie wire for attaching ceiling furring channels and for stud shoes at partitions: 16 ga.
 2. Casing Beads: 24 ga. expanded flange, square unless otherwise indicated, galvanized.
 3. Corner Beads: Keystone "Key Corner", galvanized.
 4. Screeds: 26 ga. expanded or short flange as required, galvanized. Use drip screed or mould at bottom of all vertical cement plaster surfaces.
 5. Aluminum Plaster Moldings: Fry Corp., or approved equal, extruded aluminum with clear finish. Fry numbers are used on Drawings to indicate profiles required. All runs shall be made up of longest metal lengths possible. Field paint before application: See Painting 09 91 00.

PART 3 - EXECUTION

3.01 CONDITION OF SURFACES: Inspect all surfaces to receive lathing materials and report all

defects. Commencing work implies acceptance of surfaces.

3.02 COORDINATION:

- A. Coordinate lathing work with all other work supporting, adjoining, or fastening to same.
- B. Coordinate with trades responsible for access doors and plaster frames with exact locations subject to Architect's approval.
- C. Plaster moldings, reveal expansion joints, ventilating screeds and other similar trim items embedded in plaster surfaces shall be pre-painted prior to installation. Coordinate with Painting 09 91 00.

3.03 INSTALLATION:

- A. Except where modified herein, conform to requirements of listed References, Codes and Standards and to approved manufacturer's specifications. In event of conflict, assume most stringent requirements and secure instructions from Architect before proceeding.
- B. Include all non-structural welding required for proper installation of lathing work.
- C. Install all accessory trim with pieces straight, aligned, plumb, and level, corners mitered and smooth. Provide outside corners in Portland cement plaster with corner beads. Provide metal plaster grounds at all edges of plasterwork. Cut lath full length at expansion and control joints. Hold metal lath 1/4" clear of all items such as electrical boxes, columns, etc., projecting through plaster surfaces. Install aluminum moldings level or plumb and aligned without offsets. Fasten with concealed galvanized fasteners at each bearing point (24" c-c max.). Lap felt over flanges to prevent direct contact between lath and molding.
- D. Metal Furring: In general, make all metal furring of cold rolled channels in accordance with requirements of References, Codes and Standard documents or of light gage, hat shaped furring channels spaced 16" o.c. max., and installed in strict accordance with manufacturer's specifications except that light gage channels are not acceptable for horizontal furred surfaces.
- E. Lathing: Where not otherwise noted or specified, weights and types of metal lath shall be in accordance with requirements of the listed References, Codes and Standards documents for sizers, spacings, and types of framing and furring members used.
 - 1. Types and Locations:
 - a. Vertical Cement Plaster on Framing: Paper-backed stucco netting. Provide two (2) layers, grade D minimum, over solid sheathing.
 - b. Horizontal Cement Plaster (Wood Supports): Expanded diamond mesh for supports spaced 12" cc max.; 3/8" rib lath for supports spaced 24" cc max; flat rib lath for supports.
 - 2. Lath Attachment:
 - a. Nail expanded metal and rib lath to wood frame ceiling and soffits at 6" intervals along each support with 1-1/2" x 11 ga. barbed and galvanized roofing nails with 7/16" head or 1-1/4" x 16 ga. power driven galvanized

staples at 6" cc or at ribs.

- b. Attach stucco netting to wood framing at 6" intervals with 1-1/2" x 11 ga. galvanized and barbed, 7/16" head roofing nails, or 7/8" leg x 16 ga. power driven, galvanized staples, attachments at furring crimps.

END OF SECTION

**SECTION 09 24 00
CEMENT PLASTERING**

The General Conditions, Supplementary Conditions and Division 1 General Requirements are hereby made a part of this Section as fully as if repeated herein.

PART 1 - GENERAL

1.01 DESCRIPTION:

A. Work Included: All plastering work required for the project to receive a paint finish.

B. Related Work Specified Elsewhere:

1. Section 07 60 00 Flashing and Sheet Metal.
2. Section 07 92 00 Joint Sealants.
3. Section 09 22 36 Lath.
4. Section 09 91 00 Painting.

1.02 REFERENCES, CODES AND STANDARDS: The following references, codes and standards are hereby made a part of this Section and all plastering work shall conform to the applicable requirements therein except as otherwise specified herein or shown on the Drawings. Nothing in the Drawings or these Specifications shall be construed as permitting work which is contrary to code requirements.

A. "Reference Specifications for Lathing, Furring and Plastering in California" published by California Lathing and Plastering Contractors' Assn., Inc., latest edition.

B. California Building Code.

1.03 FIRE RATED ASSEMBLIES: All fire rated plaster assemblies, including materials and methods of application used, shall be approved by the Building Code.

1.04 SUBMITTALS: Comply with requirements of Shop Drawings, Product Data and Samples Section 01340.

A. Samples: Submit samples for approval of all textured plaster finishes, 12" x 12" minimum size for each sample.

1.05 DELIVERY AND STORAGE OF MATERIALS: Only unopened packages of material (except aggregates) bearing manufacturer's and brand names will be permitted. Store cement and lime under watertight cover away from sweating walls and damp surfaces until ready for use. Remove from site any damaged or deteriorated materials.

1.06 PROTECTION: Protect all adjacent finishes and surfaces from damage or stains during plastering operations. Where machine application of plaster is employed, adjacent surfaces shall be masked or similarly protected and all overspray and droppings removed before material sets. Particular attention shall be paid to protection of glass and metal surfaces against etching caused by alkaline materials and moisture runoff or drainage therefrom.

PART 2 - PRODUCTS

2.01 MATERIALS:

- A. Stucco Finish Coat: Formulated for machine application, mill-mixed and waterproofed.
- B. Lime: ASTM C 206, Type "S" finishing hydrate.
- C. Portland Cement: ASTM C 150, Type II. Plastic cement not acceptable.
- D. Aggregates: Sand for Portland Cement Plaster: ANSI A 42.2, natural or manufactured sand graded as follows:

Percent Retained Each Sieve
(By Weight)

Sieve Size	Min.	Max.
#4	-	0
#8	0	10
#16	10	40
#30	30	65
#50	70	90
#100	95	100

- E. Fibermesh.
- F. Water: Clean and potable, free of silt and impurities detrimental to plaster.

2.02 PLASTER PROPORTIONS:

- A. Portland Cement Plaster:
 1. Scratch and Brown Coats (By Volume): 1 part Portland Cement, 3-1/2 to 4-1/2 parts sand, 1/10 part maximum dry hydrated lime or equivalent in lime putty. Add fibermesh to scratch coat per manufacturer's recommendations.
 2. Finish Coat: Prepared finish coat requiring addition of water only, texture shall be Sand Float finish. It is essential that proportions of water material be kept constant to produce an even, uniform surface. The finish coat shall receive a painter's finish.
 3. Finish coat, existing work, new finish coat to match that of the adjacent existing finish coat.

PART 3 - EXECUTION

3.01 CONDITION OF SURFACES:

- A. Inspect all surfaces to receive plaster finishes and report all defects. Starting work implies acceptance of surfaces as satisfactory.
- B. Apply no plaster to concrete or masonry surfaces which have been coated with bituminous compounds or other detrimental waterproofing agents.
- C. Examine all grounds, beads, screeds, etc., and determine that they are straight, curved, plumb, level or square as required.

3.02 PREPARATION: Properly prepare all surfaces to receive plaster in accord with manufacturer's directions and the requirements of the listed References, Codes and Standards documents.

3.03 INSTALLATION:

A. General:

1. Methods of mixing and application of plaster shall conform to requirements of the listed References, Codes and Standards documents and the specifications of particular products or systems.
2. Measure all material for plastering work in calibrated measuring boxes. Shovel measurement is not acceptable.
3. Make overnight joining at natural breaking points such as vertical arises, expansion joints, angles, and changes in plane. Each coat of plaster for an entire surface from top to bottom and between natural breaking points shall be applied in one day.
4. Where basecoat plaster finishes flush with metal frames, etc., cut plaster free from such materials before "set". Neatly groove finish coat at such junctions.

B. Application - Portland Cement Plaster:

1. Unless otherwise noted, apply plaster on metal lath in 3 coats with a minimum thickness of 7/8", finished face to back of lath.
2. Do all leveling of scratch and brown coats of Portland Cement plaster surfaces with a straightedge (rod) only and not with a darby or float.
3. Not less than 48 hours shall elapse between application of scratch and brown coats and not less than 7 days between application of brown and finish coats.
4. Moist cure each base coat of plaster for not less than 48 hours. In hot, dry, windy weather, fog spray periodically as required to prevent dryouts, glazed areas and bloom.
5. Apply finish coats over uniformly damp surfaces free of surface water.
6. Separate all structural members, outlet boxes, frames, louvers, and similar penetrations from the plaster by a neat trowel cut.

C. Surfaces and Tolerances: Finish all exposed surfaces true and even, without objectionable waves, cracks, or imperfections. Provide plaster suitable to form proper foundation for trim, moldings, paint and other finishing materials.

3.04 PATCHING: Prior to acceptance of the project, all damage, cracks, checks, discolorations and other imperfections in the work, including damage caused by other trades and damage due to shrinkage and minor structure movements of the building, shall be cut out full depth and patched to match adjoining surfaces. Costs for repair of damage caused by other trades shall be borne by those responsible for the damage.

3.05 CLEAN-UP: Clean-up upon completion in accordance with Division 1.

END OF SECTION

**SECTION 09 30 13
CERAMIC TILE**

PART 1 – GENERAL

1.01 SECTION INCLUDES

- A. Ceramic tile wall and base finish using the thin-set application method (TCA W242).
- B. Ceramic tile repair work.

1.02 RELATED SECTIONS

- A. Section 00 70 00: General Conditions.
- B. Section 07 90 00: Joint Protection.
- C. Section 09 21 16: Gypsum Board Assemblies.

1.03 REFERENCES

- A. ANSI/TCA A118.4 - Latex-Portland Cement Mortar.
- B. ANSI/TCA A137.1 - Specifications for Ceramic Tile.
- C. TCA (Tile Council of America) - Handbook for Ceramic Tile Installation.
- D. ASTM C144-04 - Aggregate for Masonry Mortar.
- E. ASTM C150 /C150M-09 - Portland Cement.
- F. ASTM C171-07 - Sheet Materials for Curing Concrete.
- G. ASTM C226-07 - Asphalt-Saturated Organic Felt used in Waterproofing.

1.04 SUBMITTALS

- A. Submit shop drawings under provisions of Section 01 33 00.
- B. Submit shop drawings indicating tile layout, perimeter conditions, junctions with dissimilar materials, thresholds, and setting details.
- C. Submit product data under provisions of Section 01 33 00.
- D. Submit product data indicating material specifications, characteristics, and instructions for using adhesives and grouts.
- E. Submit samples under provisions of Section 01 33 00. Provide existing tile sample with new sample for comparison at patch repair work.
- F. Submit manufacturer's installation instructions under provisions of Section 01 33 00.

- G. Submit maintenance data under provisions of Section 01 33 00.
- H. Include recommended cleaning and stain removal methods, and cleaning materials.

1.05 QUALITY ASSURANCE

- A. Conform to ANSI/TCA A137.1
- B. Conform to TCA Handbook for Ceramic Tile Installation.

1.06 QUALIFICATIONS

- A. Manufacturer: Company specializing in the manufacture of products specified in this Section with minimum three years experience.
- B. Installer: Company specializing in applying the work of this Section with minimum three (3) years' experience.

1.07 DELIVERY, STORAGE, AND HANDLING

- A. Deliver products to site under provisions of Section 00 70 00.
- B. Store and protect products under provisions of Section 00 70 00.
- C. Protect adhesives from freezing or overheating in accordance with manufacturer's instructions.

1.08 ENVIRONMENTAL REQUIREMENTS

- A. Do not install adhesives in a closed, unventilated environment.
- B. Maintain 50 degrees F during installation of mortar materials.

PART 2 – PRODUCTS

2.01 MANUFACTURERS - TILE

- A. DAL-TILE
- B. AMERICAN OLEAN
- C. Or approved equal.

2.02 TILE MATERIAL

- A. Repair and infill work: Ceramic Tile to match existing size, texture and color. If no matching color is available, Architect will make a selection from the tile manufacturer's full range of colors. Tile shall be considered equal to the following:

- 1. Ceramic Wall Tile: ANSI/TCA A137.1, conforming to the following:

Size	4.25" x 4.25" x 1/4"
Edge	Cushioned

Surface Finish Color	Semi-Gloss-walls, Matte Glazed-floor, Smooth As selected by Architect from Manufacturer's full range of colors and finish textures.
----------------------	--

2. Ceramic Tile Wall Base: Shall match wall tile and where new epoxy flooring and base system is being installed, new ceramic tile base shall be un-glazed type for full height of epoxy base to promote adhesion of epoxy system.
3. Ceramic Floor Tile: Matt 2x2 mosaic.

2.03 ADHESIVE MATERIALS

- A. Latex White Multi-Mastic Type 2 (Laticrete 15) for walls, ANSI A136.1.
- B. MAPEI, Type 1 Mastic.
- C. Ardex D-14.

2.04 GROUT MATERIALS

- A. Floor and Wall Grout: 100% solids epoxy, Laticrete SpectraLock 2000 IG or Laticrete SpectraLOCK PRO Grout. Color to be Bright White.
- B. MAPEI; Kerapoxy IEG

2.05 GROUT MIX

- A. Mix and proportion pre-mix grout materials in accordance with manufacturer's instructions. Grout shall be manufactured by Laticrete International, Inc. Colors as selected by Architect.

2.06 ACCESSORIES

- A. Cleavage Membrane: ASTM C226 No. 15 asphalt saturated felt or ASTM C171 4 mil. thick polyethylene film.
- B. Reinforcing Mesh: 2x2 inch size weave of 16/16 wire size; welded fabric, galvanized. Conform to ASTM A82 & A185.

PART 3 – EXECUTION

3.01 EXAMINATION

- A. Verify that surfaces are ready to receive Work.
- B. Beginning of installation means installer accepts condition of existing substrate.

3.02 PREPARATION

- A. Protect surrounding work from damage or disfiguration.
- B. Vacuum clean existing substrate and damp clean.
- C. Seal substrate surface cracks with filler. Level existing substrate surfaces to acceptable flatness tolerances.

- D. Apply sealer to surfaces as recommended by adhesive manufacturer.

3.03 INSTALLATION

- A. Install all tile in accordance with TCA Handbook for Ceramic Tile Installation.
- B. Request tile pattern from Architect if not shown. Do not interrupt tile pattern through openings.
- C. Cut and fit tile tight to penetrations through tile and provide caulk joint. Form corners and bases neatly. Align floor, base, and wall joints.
- D. Place tile joints uniform in width. Make joints watertight, without voids, cracks, excess mortar, or excess grout.
- E. Sound tiles after setting and replace any hollow units.
- F. Allow tile to set for a minimum of 48 hours prior to grouting.
- G. Provide control joints around all dissimilar materials, penetrations, transition at wall to ceiling and walls to floor, inside corners, over existing building joints and in field at TCA recommended intervals. All control joints shall extend through setting bed and be caulked with sanded sealant to match grout joints.
- H. Jointing Pattern at Interior Corners: Unless otherwise shown, tile color shall not wrap at interior corners. Start with alternate color to not interrupt pattern. See pattern detail in drawings for pattern reference.

3.04 CLEANING

- A. Clean work under provisions of 00 70 00.
- B. Clean tile surfaces.

3.05 PROTECTION

- A. Protect finished installation under provisions of Section 01 66 10.
- B. Do not permit traffic over finished floor surface.

END OF SECTION

**SECTION 09 51 00
ACOUSTICAL CEILINGS**

PART 1 – GENERAL

1.01 SECTION INCLUDES

- A. Acoustical tile.

1.02 RELATED SECTIONS

- A. Section 00 70 00: General Conditions.
- B. Section 09 90 00: Painting and Coatings.
- C. Section 26 50 00: Lighting: Light fixtures in ceiling system.

1.03 REFERENCES

- A. ASTM E1264-08 - Acoustical Ceiling Products.
- B. FS SS-S-118 - Sound Controlling Blocks and Boards (Acoustical Tiles and Panels, Prefabricated).

1.04 SUBMITTALS

- A. Submit under provisions of Section 01 33 00.
- B. Shop Drawings: Indicate tile layout and related junctions with other work or ceiling finishes, and interrelation of mechanical and electrical items related to the system.
- C. Product Data: Provide data on acoustic units.
- D. Samples: Submit two samples 6 x 12 inch in size illustrating material and finish of acoustic units.

1.05 QUALIFICATIONS

- A. Acoustical Unit Manufacturer: Company specializing in manufacturing the Products specified in this section with minimum three years documented experience.
- B. Applicator: Company specializing in performing the work of this section with minimum three years documented experience.

1.06 ENVIRONMENTAL REQUIREMENTS

- A. Maintain uniform temperature of minimum 60 degrees F and maximum humidity of 40 percent prior to, during, and after installation.

1.07 SEQUENCING

- A. Sequence work to ensure acoustical ceilings are not installed until building is enclosed, sufficient heat is provided, dust generating activities have terminated, and overhead work is completed,

tested, and approved.

B. Install acoustic units after interior wet work is dry.

1.08 EXTRA MATERIALS

A. Furnish under provisions of Section 00 70 00.

B. Provide 2 percent of total acoustical unit area of extra tile to Owner.

PART 2 – PRODUCTS

2.01 MANUFACTURERS - ACOUSTIC UNITS

A. USG Millennia™ ClimaPlus™ Tile

B. Or approved equal.

C. Substitutions: Under provisions of Section 00 70 00.

2.02 MATERIALS

A. Acoustic Tile: ASTM E1264, ASTM E84 Conforming to the following:

1. Size: 12 x 12 inches.
2. Thickness: 3/4 inches
3. Composition: Mineral.
4. Light Reflectance: .85
5. NRC Range: .50 to .60.
6. CAN Min: 40
7. Fire Hazard Classification: Class A, flame spread 25, smoke development 50.
8. Edge: Beveled.
9. Surface Color: White.

B. Stables: Recommended by tile manufacturer for concealed appearance.

PART 3 – EXECUTION

3.01 EXAMINATION

A. Verify site conditions.

B. Verify that substrate conditions are ready to receive the work of this section.

3.02 INSTALLATION

- A. Install system in accordance with manufacturer's instructions and as supplemented in this section for stapled installation to existing and repaired wood striping.
- B. Fit acoustic units in place, free from damaged edges or other defects detrimental to appearance and function.
- C. Lay directional patterned units one way with pattern parallel to longest room axis. Fit border units neatly against abutting surfaces.
- D. Install acoustic units level, in uniform plane, and free from twist, warp, or dents.
- E. Patching area as indicated on Drawings. Replace material to natural joint or nearest intersection.
- F. Apply sealant flush with the face of the tile at each staple depression in the tile.

3.03 ERECTION TOLERANCES

- A. Maximum Variation from Flat and Level Surface: 1/8 inch in 10 feet.

END OF SECTION

**SECTION 09 65 00
RESILIENT FLOORING**

PART 1 – GENERAL

1.01 SECTION INCLUDES

- A. BioBased Tile Flooring
- B. Resilient Sheet Vinyl Flooring.
- C. Resilient Base and Accessories.
- D. Subfloor testing and preparation.

1.02 RELATED SECTIONS

- A. Section 00 70 00: General Conditions.
- B. Exhibit C: Abatement of Hazardous Materials.
- C. Section 03 30 00: Cast-in-Place Concrete: Subfloor surface.
- D. Section 06 10 00: Rough Carpentry: Subfloor surface.
- E. Section 06 41 16 Plastic Laminate Clad Architectural Cabinets (for rubber base at cabinets)
- F. Section 07 26 00: Vapor Retarders
- G. Section 09 21 16: Gypsum Board Assemblies: Wall materials to receive base.

1.03 REFERENCES

- A. ASTM E84 – Surface Burning Characteristics of Building Materials
- B. FS L-F-1641 - Floor Covering, Translucent or Transparent Vinyl Surface, with Backing.
- C. FS L-F-475A - Floor Covering, Vinyl Surface (Tile and Roll), with Backing.
- D. FS SS T-312 – Tile, Floor: Asphalt, Rubber, Vinyl, Vinyl Composition, BioBased
- E. FS SS W-40 – Wall Base: Rubber.

1.04 QUALITY ASSURANCE

- A. Flooring Contractor Installer Qualifications:
 - 1. Flooring Contractor to be an established firm experienced in the installation of the specified product and shall have access to all manufacturers' required technical, maintenance, specifications and related documents.

2. Floor covering installer must be factory trained and certified for the installation of the specific products being installed.
3. Installer to provide project inspector proof of certification prior to starting work.
4. Certified installer must be present on job site while work is in progress.

B. Pre-Floor Covering Installation Meeting:

1. Contactor to notify Construction Manager with a minimum of 5-days notice when anticipated to be ready for pre-floor covering installation meeting. (After subfloor preparation is complete and ready for floor covering installation.)
2. Contractor, installer and manufacturer representative are required to attend pre-floor covering meeting. Contractor is responsible for coordinating and scheduling their attendance.
3. Construction Manager will schedule meeting with Contractor team, Project Inspector, and Architect.
4. Purpose of Meeting: To review subfloor preparation, verification of readiness for floor covering installation and use of correct products, verification of the acclimation of correct finish materials and review installation requirements.

C. Manufacturer's Field Services:

1. Manufacturer representative to attend the "Pre-Flooring" meeting.
2. Upon Owner or Architect's request, and with at least 72 hour notice, provide manufacturer's representative site visit(s) for inspection of product installation.
3. At Owner's request manufacturer representative to attend operation and maintenance training meeting for Owner's custodial staff prior to acceptance of floor covering installation.

D. Testing Laboratory Qualifications:

1. Certified, bonded, qualified and experienced agency to perform pH and moisture vapor emission tests.

1.05 SUBMITTALS

- A. Provide a complete submittal package with all components required within this section. Submit per Section 00700.
1. Product Data: Provide product data describing physical and performance characteristics, sizes, patterns, colors, material safety data sheets and manufacture's installation instructions for all proposed products.
 2. Shop Drawings:
 - a. Provide a floor plan indicating all proposed seam locations.

b. Provide a game stripping plan indicating court layouts and colors.

3. Samples:

a. Submit samples for color selection illustrating color and pattern for floor material with samples of matching welding rod seams, rubber base and transition material proposed for installation.

1.06 OPERATION AND MAINTENANCE DATA

- A. Submit cleaning and maintenance data under provisions of Section 00 70 00.
- B. Include maintenance procedures, recommended maintenance materials, and suggested schedule and products for cleaning, stripping, and re-waxing.
- C. At the request of the Owner, provide in-service training with Owner's custodial staff prior to acceptance of flooring for proper care and maintenance of floor covering.

1.07 DELIVERY, STORAGE AND HANDLING

- A. Delivery: Deliver materials in manufacturer's original, unopened, undamaged containers with identification labels intact.
- B. Storage and Protection: Store materials protected for exposure to harmful weather conditions and at a temperature and humidity conditions recommended by manufacturer. Materials should be stored in areas that are fully enclosed, weather tight with the permanent HVAC system set at a uniform temperature of at least 68 degrees F (20 degrees C) for 72 hours prior to, during and after installation.

1.08 ENVIRONMENTAL REQUIREMENTS

- A. Maintain a minimum temperature in the spaces to receive the flooring and accessories of 65°F and a maximum temperature of 100°F, 85°F for at least 48 hours before, during, and for not less than 48 hours after installation. Thereafter, maintain a minimum temperature of 55°F in areas where work is completed. Protect all materials from the direct flow of heat from hot-air registers, radiators, or other heating fixtures and appliances.
- B. Prior to testing for moisture vapor emission rate, space shall be enclosed, fully weather-tight, wet-work in space shall be completed and nominally dry, work above ceilings finished. The test site should be at the same temperature and humidity expected during normal use.
- C. Maintain lighting at a minimum uniform level of 50 or more foot candles in areas where the floor system is being installed.

1.09 CONCRETE SUBFLOOR TESTING

- A. The Contractor shall be responsible for conducting calcium chloride test. Three (3) tests are required for the first 1,000 square feet and one additional test for every 1,000 square feet thereafter to ensure concrete moisture emissions do not exceed manufacturer's requirements for different product types specified under this section per 1,000 square feet within a 24-hour period for areas to receive linoleum.

1. F1869-98 Standard Test Method for Measuring Moisture Vapor Emission Rate of Concrete Subfloor Using Anhydrous Calcium Chloride. This test method covers the quantitative determination of the rate of moisture vapor emitted from below-grade, on-grade, and above-grade (suspended) concrete floors.
- B. The Flooring Contractor shall verify in writing to the Owner, a minimum of thirty (30) days prior to scheduled resilient flooring installation, the following substrate conditions:
1. Moisture: Initial emission rate, as tested with a calcium chloride test kit, per ASTM F1869-89 requirements.
 2. Alkalinity: pH level.
- C. Contingency for High Moisture and /or Alkalinity Readings:
1. New Construction (New Concrete Slab)
 - a. If the Contractor's test results indicate that the slab moisture and/or alkalinity readings are in excess of flooring manufacturer's requirements, the Owner's representative will initiate independent testing to confirm results and will initiate additional testing using petrographic analysis to determine if the Water Cement Ratio and sufficient hydration has taken place.
 - 1) If it is determined that the Specifications were not followed in their entirety, water/cement ratio (as specified), and or the concrete surface has been inadequately hydrated, the Contractor responsible for the placement of the cement shall be responsible for the costs associated with the calcium chloride re-test and petrographic analysis and subsequent remediation requirements by the use of Vapor Retarders in accordance with section 07250.
 - 2) If it is determined that the Specifications were followed in their entirety, water/cement ratio (as specified), and or the concrete surface has been adequately hydrated; then the Allowance established in the Bid Form for the installation of the Vapor Retarders as specified in section 07260 shall be utilized.
 2. Modernization Construction (Existing Concrete Slab)
 - a. If the Contractor's test results indicate that the slab moisture and/or alkalinity readings are in excess of flooring manufacturer's requirements, the Owner's representative will initiate independent testing to confirm results.
 - 1) If the independent test results do not substantiate the Contractor's findings, then the Contractor will be directed to proceed with the floor covering installation and the retesting cost will be back-charged to the contractor.
 - 2) If the independent test results confirm the Contractor's findings, then the Allowance established in the Bid Form for the installation of the Vapor Retarders as specified in Section 07 26 00 shall be utilized.

1.10 EXTRA MATERIALS

- A. Provide a minimum of 40 sq ft of each type and color of flooring and 10 lineal feet of base and transition pieces of each material and color specified or 2 % whichever is greater.
- B. Provide 1-year of all required maintenance products commencing on the recordation date of the Notice of Completion. Maintenance products are to be clearly identified and left on site in area designated by District representative.

1.11 WARRANTY

- A. Installation Warranty: Two (2) year installation warranty commencing on recordation date of the Notice of Completion.
- B. Manufacturer's Warranty: Five (5) year manufacturer warranty commencing on recordation date of the Notice of Completion.

PART 2 – PRODUCTS

2.01 MATERIALS

- A. BioBased Floor Tile, General: ASTM F1066, Class 2 – through pattern. Coefficient of Friction per ASTM D2047 meets recommended value of 0.6. Composition 1, 12 inch x 12 inch x 1/8 inch gauge. Pattern and color to match existing at repair areas or as selected by Owner Representative from Manufacturer's standard range for new or replacement floors.
 - 1. Armstrong BioBased Migrations.
 - 2. Approved equal.
- B. Sheet Vinyl Flooring: General: ASTM 1913; Coefficient of Friction per ASTM D2047 meets recommended value of 0.6. 6 foot width; .080 inch (2mm) overall gauge; self coving base, color as selected by Owner Representative from Manufacturer's standard range with matching weld rod for fully welded seams. Use at interior spaces where water is present.
 - 1. Armstrong, MEDINTECH homogeneous
 - 2. Approved equal.
- C. Rubber Wall Base: General: FS-SS-W-40, Type 1 with matching end stops. 4" high and 6" high and 1/8 inch gauge. No manufactured corners.
 - 1. Burke Industries, Type TS.
 - 2. Flexco Floors, Wallflowers Series.
 - 3. Roppe Rubber Corp, Pinnacle Series.
 - 4. Approved equal.
- D. Accessories:

1. Resilient Edge Strips: 1/8 inch thick, tapered or bullnose, minimum of 1 inch wide, color to be selected.
 - a. Burke Mercer, Carpet to Resilient Transition, #152
 - b. Johnsonite, Adaptor, CTA-XX-A
 - c. Or approved equal.
2. Adhesive: Waterproof, EPA acceptable and as recommended by manufacturer.
3. Primer: Non-staining type as recommended by flooring manufacturer.
4. Leveling and Patching Compounds: Latex type as recommended by flooring manufacturer.
5. Metal Trim Cap: Provide at top edge of sheet vinyl cove.
6. Sealer and Wax wear coats: As recommended by manufacturer.

PART 3 – EXECUTION

3.01 EXAMINATION

A. New Construction (New Concrete Slab)

1. Installer must examine areas and conditions under which resilient flooring and accessories are to be installed and must notify General Contractor in writing of conditions detrimental to proper and timely completion of work. Do not proceed with work until unsatisfactory conditions have been corrected in manner acceptable to Owner and Architect.
2. The Contractor shall be responsible for conducting calcium chloride test. Three (3) tests are required for the first 1,000 square feet and one additional test for every 1,000 square feet thereafter to ensure concrete moisture emissions do not exceed 5.0 lbs per 1,000 square feet within a 24-hour period for areas to receive flooring. Submit test results a minimum of thirty (30) days prior to scheduled resilient flooring installation to Owner's representative.
3. Verify that new surfaces are smooth and flat with maximum variation of 1/8 inch in 10 ft, and are ready to receive work.
4. Beginning of installation on new substrates means acceptance of substrate. The existing substrates will require as much preparation as necessary to provide proper installation of new materials.

B. Modernization Construction (Existing Concrete Slab)

1. If existing flooring was determined to be asbestos containing and required abatement, verify that the abatement work has been accepted by the Owner's representative prior to commencing work.

2. The Contractor shall be responsible for conducting calcium chloride test. Three (3) tests are required for the first 1,000 square feet and one additional test for every 1,000 square feet thereafter to ensure concrete moisture emissions do not exceed 5.0 lbs per 1,000 square feet within a 24-hour period for areas to receive flooring. Submit test results a minimum of thirty (30) days prior to scheduled resilient flooring installation to Owner's representative.

3.02 PREPARATION

A. New Construction (New Concrete Slab)

1. Install underlayment where flooring is being installed on a wooden subfloor per the manufacturer's instructions.
2. Remove sub-floor ridges and bumps. Fill low spots, cracks, joints, holes, and other defects with subfloor filler.
3. Apply, trowel, and float filler to leave a smooth, flat, hard surface.
4. Prohibit traffic from area until filler is cured.
5. Prepare floor substrate to be smooth, rigid, flat, level, permanently dry, clean and free of foreign materials such as dirt, paint, grease, oils, solvent, curing and hardening compounds, sealers, asphalt and old adhesive residue. Vacuum clean substrate.
6. Apply primer to concrete surfaces.

B. Modernization Construction (Existing Concrete Slab)

1. Remove existing finishes, adhesives and other materials as necessary to properly prepare existing substrates. (Refer to asbestos abatement procedures.)
2. Install underlayment where flooring is being installed on a wooden subfloor per the manufacturer's instructions.
3. Remove sub-floor ridges and bumps. Fill low spots, cracks, joints, holes, and other defects with subfloor filler.
4. Fill low spots, cracks, joints, holes and other defects with filler prior to flooring installation.
5. Apply, trowel, and float filler to leave a smooth, flat, hard surface.
6. Prohibit traffic from area until filler is cured.
7. Prepare floor substrate to be smooth, rigid, flat, level, permanently dry, clean and free of foreign materials such as dirt, paint, grease, oils, solvent, curing and hardening compounds, sealers, asphalt and old adhesive residue. Vacuum clean substrate.
8. Apply primer to concrete surfaces.

3.03 BIOBASED TILE INSTALLATION

- A. Install flooring in strict accordance with the procedures found in the BioBased Tile Installation System at www.floorexpert.com. Additional installation tips can be found in the Commercial Quick Hits BBT installation tips sheet, FP7440F8276-412.
- B. Install flooring wall to wall before the installation of floor-set cabinets, casework, furniture, equipment, movable partitions, etc. Extend flooring into toe spaces, door recesses, closets, and similar openings as shown on the drawings.
- C. If required, install flooring on pan-type floor access covers. Maintain continuity of color and pattern within pieces of flooring installed on these covers. Adhere flooring to the subfloor around covers and to covers.
- D. Scribe, cut, and fit to permanent fixtures, columns, walls, partitions, pipes, outlets, and built-in furniture and cabinets.
- E. Install flooring with adhesives, tools, and procedures in strict accordance with the manufacturer's written instructions. Observe the recommended adhesive trowel notching, open times, and working times.

3.04 SHEET VINYL INSTALLATION

- A. Install in accordance with manufacturers' instructions and recommendations with fully welded seams.
- B. Install flooring square with room axis and in accordance with approved shop drawing.
- C. Layout sheet goods in a manner to minimize seams and avoid seams in traffic areas. Avoid cross seams, filler pieces and strips. Match edges for color shading and pattern at the seams in compliance with the manufacturer recommendations.
- D. Spread only enough adhesive to permit installation of materials before initial set.
- E. Apply adhesive using 1/16" x 1/16" x 1/16" square notch trowel and lay flooring into wet adhesive and roll with a 100 pound roller.
- F. Terminate flooring at centerline of door openings where adjacent floor finish is dissimilar.
- G. Scribe, cut, fit flooring to butt tightly to vertical surfaces, permanent fixtures, and built-in furniture, including pipes, outlets, edgings, thresholds, nosing and cabinets
- H. Install edge strips at unprotected or exposed edges, and where flooring terminates.
- I. Install flooring on covers for telephone and electrical ducts, and similar items occurring within finish floor areas. Maintain overall continuity of color and pattern with pieces of flooring installed on these covers.
- J. Adhere flooring to prepared substrate without producing open cracks, voids, raising and puckering at joints, telegraphing to adhesive spreader marks, or other surface imperfections in completed installation
- K. Fully fuse all seams with color coordinated welding rod.

3.05 INSTALLATION – INTEGRAL COVERED BASE

- A. Install all sheet vinyl flooring with integral covered base with backer rod at cove. Install covered base on entire wall perimeter including toe spaces and open ends of cabinets. Set in adhesive as recommended by the manufacturer. All joints shall be plumb, flush, mitered, tightly fitted and inconspicuous. Install with metal trim piece.

3.06 INSTALLATION – TOP SET RUBBER BASE MATERIAL

- A. Install VCT with resilient wall base on entire wall perimeter including toe spaces and open ends of cabinets. Set all bases in adhesive as recommended by the manufacturer. All joints in bases, shall be plumb, flush, tight and inconspicuous. Seat top edge and back of base firmly against the wall. Wrap base around all outside corners and no seams within 12" of corners. Interior corners shall be mitered and tightly fitted.

3.07 PROTECTION

- A. Prohibit traffic on floor finish for 5-days after installation and prior to cleaning.
- B. Prohibit traffic on floor for a minimum of 24 hours after sealed and waxed.
- C. Protect flooring from damages by other trades prior to owner occupancy.

3.08 INITIAL CLEANING

- A. Cleaning: After new floor finish has set for a minimum of 5-days, remove excess adhesive from floor, base, and wall surfaces. Contractor to be responsible for performing initial maintenance requirements based on procedures listed below:
 - 1. Sweep or dust all floors.
 - 2. Scrub floor using a neutral cleaner. Do not remove manufacturer's coating.
 - 3. Rinse floor thoroughly.
 - 4. Apply two (2) coats of sealer. Allow 45 minutes between coats.
 - 5. Apply three (3) coats of wax. Allow 45 minutes between coats.

END OF SECTION

**SECTION 09 91 00
PAINTING**

PART 1 - GENERAL

1.01 DESCRIPTION:

- A. Work included: Surface preparation, paint and finish of exposed surfaces listed on the Painting Schedule in Part 3 of this Section and the Finish Schedule on the Drawings, and as otherwise recommended by the paint manufacturer for unlisted surfaces, as specified herein and as needed for a complete and proper installation.
- B. Related Work Specified Elsewhere:
 - 1. Section 06 41 16 Plastic Laminate Clad Architectural Cabinets (for refinishing of existing wood cabinets selected for reuse).
 - 2. Section 08 12 13 Hollow Metal Frames.
 - 3. Section 08 14 23 Flush Wood Doors.
 - 4. Section 09 21 16 Gypsum Board Assemblies.

1.02 REFERENCES:

- A. ANSI/ASTM D16 – Definitions of Terms Relating to Paint, Varnish, Lacquer, and Related Products.
- B. ASTM D2016 – Test Method for Moisture Content of Wood.
- C. State of California Department of Transportation Standard Specifications, Latest Edition.
- D. Regulation 8, Rule 3, of Bay Area Air Quality Management District as it pertains to organic compounds and Architectural coatings.

1.03 DEFINITIONS:

- A. Conform to ANSI/ASTM D16 for interpretation of terms used in this Section.

1.04 QUALITY ASSURANCE:

- A. Product Manufacturer: Company specializing in manufacturing quality paints and finish products with 10 years experience.
- B. Applicator: Company specializing in commercial painting and finishing with 5 years documented experience approved by product manufacturer.
- C. Workmanship shall be of highest quality in all respects.
- D. Apply paint materials in accordance with manufacturers' specifications and recommendations.
- E. Environmental Conditions: Surfaces are to be painted only when free from moisture. No

painting is to be preformed when temperature is below 50 degrees F, except when specifically directed otherwise in writing by the Owner.

1.05 REGULATORY REQUIREMENTS:

- A. Conform to applicable code for flame/fuel/smoke rating requirements for finishes.
- B. Conform to Bay Area Quality Management District requirements.

1.06 SUBMITTALS: Comply with requirements of Shop Drawings, Product Data and Samples Section 01 33 00.

- A. Submit product data for the following items to District for review and approval:
 - 1. List of materials to be used:
 - a. Surface Cleaning Materials.
 - b. Surface Patching and Caulking Materials.
 - c. Painting Material.
 - 2. Manufacturer's technical specifications, M.S.D.S. data sheets and additional information if requested for each painting material listed.
 - 3. Color and Finish Samples: Samples of each color and finish required. Such approved samples will constitute standards for color and finish for acceptance or rejection of completed work. Make samples 8 x 10 inches in size. Furnish six (6) samples of each color and finish. Resubmit additional samples if necessary. Samples are to be labeled on the back side with the name of the project, contractor's name, color name, type of paint, and name of paint manufacturer.
- B. On actual wood surfaces, provide two 4 x 8 inch samples of natural and stained wood finish. Label and identify each as to location and application.
- C. Submit manufacturer's application instructions.
- D. Submit copy of surface moisture test results to the District.
- E. Certification of factory mixed colors from paint manufacturer.

1.07 FIELD SAMPLES:

- A. Provide samples under provisions in Submittals.
- B. On actual wall surfaces and other exterior building components, duplicate painted finishes of prepared samples. Provide full-coat finish samples on at least 100 sq.ft. of surface, as directed. Provide additional samples if necessary to demonstrate the specified sheen, color and texture. Simulate finished lighting conditions for review of in-place work.
- C. Final acceptance of colors will be from samples applied on the job.

1.08 DELIVERY, STORAGE AND HANDLING:

- A. Deliver paint materials to site in manufacturer's original unopened containers with product

designation, batch numbers and date of manufacture clearly visible. District Inspector to verify.

- B. Store paint materials and equipment in well-ventilated storage container provided by the contractor and in a location approved by the Owner. Receiving and opening all paint materials will be performed in this room. Keep storage space neat, clean and accessible at all times. Oily or paint filled rags will be removed and disposed of each day. No paint materials will be left unsecured.
- C. Container labeling to include manufacturer's name, type of paint, brand name, brand code, coverage, surface preparation, drying time, cleanup, color designation, and instructions for mixing and reducing.
- D. Store paint materials in minimum ambient temperature of 45 degrees F, and a maximum of 90 degrees F, in well ventilated area; unless required otherwise by manufacturer's instructions.
- E. Take precautionary measures to prevent fire hazards and spontaneous combustion.

1.09 ENVIRONMENTAL REQUIREMENTS:

- A. Provide continuous ventilation and heating facilities to maintain surface and ambient temperatures above 45 degrees F for 24 hours before, during, and 48 hours after application of finishes, unless required otherwise by manufacturer's instructions.
- B. Do not apply exterior coatings during rain, or when relative humidity is above 80 percent.
- C. Provide the District with M.S.D.S. data for all products being used, a copy of which is to be posted at the job site.
- D. Minimum Applications Temperatures for Latex Paints: 45 degrees F for interiors, 50 degrees F for exterior unless required otherwise by manufacturer's instructions.
- E. Minimum Application Temperature for Varnish and transparent finishes: 65 degrees F for interior or exterior unless required otherwise by manufacturer's instructions.

1.10 EXTRA STOCK:

- A. Provide (2) gallons of each color and sheen for opaque paint products. Provide in clean, unused containers.

1.11 GUARANTEE:

Provide a written guarantee covering the adherence and quality of the finish for a period of three (3) years from the date of final acceptance. Guarantee shall state that the Contractor will refinish without charge to the Owner any portion of the work, including adjacent surfaces if necessary, which evidences blistering, peeling, chalking, change of color, or other noticeable defects within this period.

PART 2 - PRODUCTS

2.01 MANUFACTURERS:

- A. Manufacturer's catalog names and number of paint types in this Section herein are based

on products of Benjamin Moore & Company, and is the standard of quality against which the District will judge equivalency. The quantity of titanium dioxide, the use of clays, aluminum silicate, talc and the purity of acrylic materials are a few of the criteria which will be used by the District in determining equivalency of materials.

2.02 MATERIALS:

- A. Coatings: Factory mixed colors. Pigments shall be fully ground; maintaining a soft paste consistency capable of being readily and uniformly dispersed to a homogeneous coating.
- B. Coatings: Good flow and brushing properties, capable of drying or curing free of streaks or sags. Dry film thickness of each coat shall comply with minimum published recommended thickness by the paint manufacturer.
- C. Accessory Materials: Linseed oil, shellac, turpentine, paint thinners and other materials not specifically indicated but required to achieve the finishes specified, shall be of commercial quality and approved by paint manufacturer.
- D. All paint materials shall conform to BAAQMD Regulation 8, Rule 3.

2.03 FINISHES:

- A. Refer to schedule at end of Section for surface finish schedule. Color selection packages will identify colors and applications locations for each individual site as issued by the District.

PART 3 - EXECUTION

3.01 INSPECTION:

- A. Verify the substrate conditions are ready to receive work as instructed by the product manufacturer.
- B. Examine surfaces scheduled to be finished prior to commencement of work. Report any condition to the Construction Manager that may potentially affect proper application.
- C. Measure moisture content of surfaces using electronic moisture meter. A minimum of four tests throughout the project area are required. Do not apply finishes unless moisture content of surfaces is below the following maximums:
 - 1. Gypsum Wallboard: 12 percent.
 - 2. Interior Located Wood: 15 percent, measured in accordance with ASTM D2016.
 - 3. Exterior Located Wood: 15 percent, measured in accordance with ASTM D2016.
- D. Inspector must review and accept substrate prior to contractor beginning installation.

3.02 GENERAL PREPARATION:

- A. Prior to the start of surface preparation in any area, protective coverings for all items that are not to be painted shall be provided and installed to the satisfaction of the Construction Manager and/or Architect.
- B. Methods for installation and protection of work: Provide and maintain all lifts, scaffolding,

and ladders and drop cloths required for this work. Painted and finished surfaces subject to damage or defacement due to other work on the building will be properly protected and covered. Contractor will be responsible for any and all damages to painted work and to that of other areas caused by his operation.

- C. No painting or finishing will be started until the surfaces to be painted or finished are in proper condition in every respect, and approved by the Construction Manager and/or Architect.
- Surfaces to be painted will be clean, dry, sound and free of dirt, rust, grease, traffic scum, dust, loosely adhering paint, surface chalk, staples, tacks, and any other substances which might interfere with the functioning of the painting or coating system.
- D. Remove electrical plates, hardware, light fixture trim, acrylic guards and fittings prior to preparing surfaces or finishing.
- E. Correct defects and clean surfaces which affect work of this Section. Where wood is loose or missing, repair and paint.
- F. Seal marks such as felt-tipped marking pens, etc. with Benjamin Moore's SPS. Insure that these marks do not bleed through surface finishes.
- G. Impervious Surfaces: Remove mildew by scrubbing with solution of tri-sodium phosphate and bleach. Rinse with clean water and allow surface to dry.
- H. Aluminum Surfaces Scheduled for Paint Finish: Remove surface contamination by steam or high-pressure water. Remove oxidation with acid etch and solvent washing. Apply etching primer immediately following cleaning. Care must be taken to avoid etching glass. Damaged glass will be replaced at not cost to Owner.
- I. Insulated Coverings: Remove dirt, grease and oil from canvas and cotton.
- J. Gypsum Board Surfaces: Latex fill minor defects with Benjamin Moore's Lightweight Spackle #057-01. Spot prime defects after repair with Moorcraft Primer Underbody #284.
- K. Galvanized Surfaces: Remove surface contamination and oils and wash with solvent. Apply coat of etching primer.
- L. Uncoated Steel and Iron Surfaces: Remove grease, scale, dirt and rust. Where heavy coatings of scale are evident, remove by wire brushing or sandblasting and clean by washing with solvent. Apply a treatment of phosphoric acid solution, ensuring weld joints, bolts and nuts are similarly cleaned. Spot prime after repairs.
- M. Shop Primed Steel Surfaces: Scrape, grind, and sand to remove loose primer and rust. Feather edges to make touch-up patches inconspicuous. Clean surfaces with solvent. Prime bare steel surfaces. Prime metal items including shop primed items. Areas where all rust cannot be removed, use Benjamin Moore's Rust Converter #M-84-00.
- N. Exterior Wood Scheduled to Receive Paint Finish: Remove dust, grit, and foreign matter. Seal knots, pitch streaks, and sappy sections. Fill nail holes with tinted exterior Benjamin Moore's Moorlastic 45 year caulking compound after prime coat has been applied.
- O. Exterior Plaster: Allow plaster to cure for 30 days prior to painting.
- P. Metal Doors Scheduled for Painting: Paint exterior face, sides and top, and bottom edges.

- Q. Remove all loose nails, screws or staples, and patch accordingly.
- R. Spot prime all repairs, patching and bare substrate prior to application of finish coat.
- S. Metal Panels: Spot prime bare metal with Ironclad Retard-X Rust Inhibitive Latex Primer, fill dents and gouges with Bondo, spot prime patches and repairs, apply specified coats.
- T. At all existing upper cabinets identified to be salvaged for reuse: Remove and replace all existing pulls, lightly but thoroughly sand/scuff exterior exposed surfaces without damaging stain or exposing bare wood, clean with TSP solution, fill all holes, pits, dings, and damage as required to provide a smooth surface for new clear satin sealer. Apply sealer to exterior surfaces of reused cabinets only including cabinet body, tops, sides, bottoms, front faces and doors/exposed door edges. Remove and reinstall door glazing. Take care to not apply sealer to existing hinges which are to remain. Interior portions of cabinets, doors and shelves are not required to be refinished, however shall be cleaned thoroughly and polished with a wax or oil furniture polish. Where sections of cabinets are required to be shortened, cut/modify at cabinet module, sand exposed edges clean and smooth, fill holes left by shelf brackets and refinish newly exposed cabinet end with stain finish and sealer to match balance of refinished cabinets. See Section 06 42 16 Plastic Laminate Clad Architectural Cabinets for further information on preparation for cabinets designated for reuse.
- U. At all existing doors to be repainted, remove all existing hardware, infill all abandoned hardware preps, fill all gouges, nicks and other damages, and sand smooth prior to new primer and paint. Remove existing vision panel frames, paint, reinstall and clean glass.

3.03 PROTECTION:

- A. Protect all concrete walks, landscaping, floors, prefinished materials and other items not scheduled to receive new paint.
- B. Repair damage to other surfaces caused by work of this Section at no additional cost to Owner.
- C. Furnish drop cloths, shields, and protective methods to prevent spray or droppings from disfiguring other surfaces.
- D. Remove empty paint containers from site at end of each day and protection upon completion in the area of work.

3.04 APPLICATION AND WORKMANSHIP:

- A. All painting is to be performed by skilled and experienced mechanics, working under the supervision of a capable foreman. All workmanship shall be of the highest quality and to the complete satisfaction of the District Inspector. All materials shall be applied in accordance with the manufacturer's directions and in compliance with the manufacturer's specifications. All material shall be sprayed and backrolled, evenly brushed or smoothly rolled on without runs or sagging, and free from drips, ridges, laps and brush marks. Ensure that all coats are thoroughly dry before applying succeeding coats. Sand surfaces and dust clean between coats as necessary to produce a smooth finish.
- B. Prime coat shall not be applied until cleaned and Construction Manager and/or Architect has approved prepared surfaces. Finish coat of paint shall not be applied until prime coat and patching have been inspected and approved by Construction Manager and/or

Architect. Prime coat will be tinted lighter than the finish coat.

- C. Putty or caulking will be applied after surface is primed and primer is dry.
- D. Concrete, stucco and plaster surfaces will not be painted until the surface is dry and contains minimum moisture.
- E. Completed painted surfaces will be free of blistering, running, peeling, scaling, streaks and stains, and the colors of all surfaces will remain free from fading.
- F. The finish surface for all doors will be smooth. A stipple or texture surface from rolling or brushing will not be accepted. Where existing doors are scheduled to be refinished, this shall also include the repainting of accompanying door frame. Doors shall be removed for preparation and paint shall include door stiles and casings. Paint tops, bottom and edges of doors to match exterior paint schedule. Prepare doors and door frame so as to insure proper operation after completion of painting.
- G. Paint shop primed equipment. Paint shop prefinished items to colors selected by Architect.
- H. Remove wall/door louvers, grilles, covers, and access panels on mechanical and electrical components and paint separately.
- I. Prime and paint insulated and exposed pipes, conduit, boxes, insulated and exposed ducts, hangers, brackets, collars and supports, except where items are prefinished. Mask any identifying markings, tags, name plates or stickers and/or replace if accidentally painted.
- J. Paint exposed conduit and electrical equipment occurring in finished areas.
- K. Reinstall electrical plates, hardware, light fixture trim, and fittings removed prior to finishing. Replace cracked or broken items.
- L. Paint area behind soffit vents and similar conditions. Do not paint over insect screens except as needed to match colors.
- M. Provide a total dry film thickness not less than the specified amount in the finish schedule.

3.05 CLEANING, TOUCH UP:

- A. As work proceeds, promptly remove paint where spilled, splashed or splattered.
- B. During progress of work, maintain premises free of accumulation of tools, equipment, surplus materials, and debris.
- C. Collect cotton waste, cloths, and material which may constitute a fire hazard. Place in closed metal containers, and remove daily from site.
- D. When cleaning airless or electro-static spray equipment, all cleaning material to be disposed of properly by contractor. No material is to be poured down drains or into the ground.
- E. Upon completion of the painting work, contractor will remove from the premises and dispose of properly all scaffolding and equipment, surplus material, empty containers, and other debris resulting from his operations. The building and surrounding areas shall be

left clean and neat in all respects. Do not use school debris boxes for disposal.

- F. Runs, sags, misses, holidays, stains, and other defects in the painted surfaces, including inadequate coverage and mil thickness, shall be satisfactorily touched up, refinished or repainted as necessary.
- G. Leave all glass areas, stucco surfaces, floors and walls, hardware, and any other surfaces clean and free from any paint, stain, spattering, smears or smudges which are the result of his operation. Contractor will replace any glass damaged in any way by his operations. This will include all glass areas of the buildings. Special cleaning solution must be used on plastic glazing areas. DO NOT SCRAPE PLASTIC GLAZING.

3.06 SCHEDULE – EXTERIOR SURFACES:

A. Cement Plaster:

- 1. One Prime coat Benjamin Moore All Purpose 100% Acrylic Primer #023.
- 2. Two finish coats Benjamin Moore MoorGard Low Lustre Fortified Acrylic House Paint #103.

B. Steel – Unprimed:

- 3. One prime coat Acrylic Metal Primer (M04)
Dry Mil Film Thickness 1.5 – 2.5
- 4. One finish coat Acrylic Gloss Enamel, (M28)
Dry Mil Film Thickness 1.5 – 2.5

C. Steel – Shop Primed:

- 1. One prime coat Acrylic Metal Primer (M04)
Dry Mil Film Thickness 1.5 – 2.5
- 2. One finish coat Acrylic Gloss Enamel (M28)
Dry Mil Film Thickness 1.5 – 2.5

D. Steel – Galvanized:

- 1. One prime coat Acrylic Metal Primer (M04)
Dry Mil Film Thickness 1.5 – 2.5
- 2. One finish coat Acrylic Enamel (M28)
Dry Mil Film Thickness 1.5 – 2.5

E. Wood Siding, Fascia, Soffit and Trim:

- 1. One prime coat Fresh Start Alkyd Primer (C024-00/04)
Dry Mil Film Thickness 1.5 **(or)**
One prime coat Super Spec Busan 100% Acrylic Exterior Primer
Dry Mil Film Thickness 1.2 as specified
- 2. Two finish coats Semi-Gloss # 170 Moorecraft Super Spec Latex House and Trim Paint

- F. Painted Flashing, Louvers, Misc. Metals:
 - 1. One prime coat Acrylic Metal Primer (M04)
Dry Mil Film Thickness 1.5 – 2.5
 - 2. One coat Acrylic Gloss Enamel (M28)
Dry Mil Film Thickness 1.5 – 2.5
- G. Metal Doors:
 - 1. One prime coat Fresh Start Alkyd Primer (C024-00/04)
Dry Mil Film Thickness 1. or
One Prime coat Acrylic Metal Primer (M04)
Dry Mil Film Thickness 1.5 – 2.5 as specified
 - 2. Two coats Acrylic Gloss Enamel (M28)
Dry Mil Film Thickness 1.5 – 2.5

3.07 SCHEDULE – INTERIOR SURFACES – as applicable:

- A. Drywall – New – Flat Finish, Level 4
 - 1. One Prime Coat Benjamin Moore's Super Hide #284
Dry Mil Thickness .8
 - 2. One or two Finish Coats Super Hide Vinyl Latex Flat #282
Dry Mil Thickness 1.0 each coat
- B. Drywall – New – Eggshell Finish
 - 1. One Prime Coat Benjamin Moore's Super Spec #282
Dry Mil Thickness .8
 - 3. One or two Finish Coats Super Hide Eggshell Enamel #286
Dry Mil Thickness 1.4 each coat
- C. Drywall – New – Semi-Gloss Finish
 - 1. One Prime Coat Benjamin Moore's Super Spec Enamel Undercoat #253
Dry Mil Thickness 1.1
 - 1. One or two Finish Coats Super Hide Latex Semi-Gloss Enamel #283
Dry Mil Thickness 1.0 each coat
- D. Wood – New – Gloss Finish
 - 1. One Prime Coat Benjamin Moore # C024 Fresh Start Alkyd Primer

Dry Mil Thickness 1.1
 - 2. Two Finish Coats M28 D.T.M. Acrylic Gloss Enamel
Dry Mil Thickness 1.0 each coat
- E. Ducts, Conduits, J-boxes, Pipes and related supports and brackets

1. One prime coat Benjamin Moore M04 Acrylic Metal Primer
 2. Two Finish Coats # 314 Waterborne Satin Impervo 100% Acrylic
- F. Drywall – Previously Painted – Flat Finish (If existing surface is a semi-gloss finish or higher, use the Moorcraft Super Hide Primer #284 to insure good adhesion).
1. One or two Finish Coats Moorcraft Super Hide Vinyl Latex Flat #282
Dry Mil Thickness 1.0 each coat
- G. Concrete Floors – Non-Painted
1. Two finish coats Moore's Latex Floor and Patio Enamel, #122. Dry thickness of 0.9 mil each coat. Follow manufacturer's recommendations for surface preparation and finish including use of non-slip additives.
- H. Existing Stained Wood (Varnish Finish)
1. 1st coat – Light stain to provide uniform finish, match existing tone
 2. 2nd and 3rd coats - WOOD PRIDE® Professional Wood Finishes Water-Based Satin Varnish 1902 or as otherwise determined compatible with existing finish. Test area of existing finished cabinets scheduled for reuse/refinish to determine best compatible clear finish coat material.

END OF SECTION

**SECTION 09 92 16
VINYL-COATED FABRIC WALL COVERINGS**

The General Conditions, Supplementary Conditions and Division 1 General Requirements are hereby made a part of this Section as fully as if repeated herein.

PART 1 – GENERAL

1.01 DESCRIPTION OF WORK:

- A. Extent of vinyl covered tackboard required is indicated on Drawings and/or as scheduled.
 - 1. Vinyl wall covering factory applied over ½" thick fiberboard.
- B. Related Work Specified Elsewhere:
 - 1. Section 06 10 00 Rough Carpentry.
 - 2. Section 06 31 16 Plastic Laminate Clad Architectural Cabinets.
 - 3. Section 08 51 13 Aluminum Windows.
 - 4. Section 09 21 16 Gypsum Board Assemblies.
 - 5. Mechanical and Electrical Sections.

1.02 QUALITY ASSURANCE:

- A. Manufacturer:
 - 1. Provide each type of tackboard as produced by a single manufacturer including recommended primers, adhesives, and sealants.
- B. Installer:
 - 1. A firm specializing in tackboard work and with not less than three years of experience in installing vinyl covered tackboard similar to those required for this work. The mechanic installing board shall provide examples of similar successful projects.
- C. Fire hazard classification:
 - 1. Provide materials bearing UL label and marking, indicating fire hazard classification of wall covering, as determined by ASTM E 84.
- D. Provide materials with the following fire hazard classification:
 - 1. The flame spread rating of the vinyl cover shall be Class 1 with a flame spread rating of not more than 25.
 - 2. The ½" thick tackboard underlayment shall be Class 3 rated, flame spread rating of 76 or less.

1.03 SUBMITTALS: Comply with requirements of Shop Drawings, Product Data and Samples Section 01 33 00.

A. Product Data:

1. Submit manufacturer's technical data and installation instructions including adhesives.

B. Samples:

1. Submit samples of each type of tackboard illustrating full range of color and pattern variation; submit sets of all moldings and trims.

C. Certification:

1. Submit manufacturer's certification that all materials furnished for the work comply in all respects with requirements specified.

1.04 DELIVERY AND STORAGE:

A. General:

1. Comply with instructions and recommendations of manufacturer and as herein specified.

1.05 JOB CONDITIONS:

- A. Maintain constant minimum temperature of 60 degrees F at areas of installation for a least 72 hours before and 48 hours after application of materials.
- B. Illuminate areas of installation using building's permanent lighting system; temporary lighting alone will not be acceptable.

PART 2 - PRODUCTS

2.01 MATERIALS:

A. Recycled Content Vinyl Covered Tackboard:

1. General:

- a. Comply with FS CC-W-408 for vinyl types required, and comply with requirements specified herein.

2. All recycled vinyl wall covering shall be medium duty (VWC-MD), Type II, Class A, total weight not less than 9.5 oz. per sq. yd., vinyl coating not less than 7 oz. per sq. yd., fabric backing of Osnaburg or drill.

3. Color-pattern/texture:

- a. Burlap pattern or similar.
- b. Color selected from manufacturer's full range standard colors.

- c. All colors shall be as selected by Architect from the manufacturer's full range of standard colors and textures. Multiple colors may be selected but will be limited to not more than two colors in the total work area.
- 4. Manufacturer:
 - a. Chatfield-Clarke Company; 14614 Valley Boulevard; Fontana, California, 92335, (909) 823-4297.
 - b. Approved equal.
- B. Accessory items:
 - 1. Adhesives:
 - A. Provide manufacturer's recommended adhesive, primer, and sealer, produced expressly for use with selected wall covering on substrate as shown on drawings. Provide materials which are mildew-resistant and non-staining.
 - 2. Provide edge moldings around door and window frames and around all other building features which penetrate vinyl covered tackboard (such as existing fire alarm devices, clock/speakers and other items not scheduled to be relocated).
 - 3. Edge moldings shall be covered with factory applied veneer to match color and texture of vinyl wall covering.
 - 4. Provide edge moldings at the bottom of tackboard panels where shown in the detail drawings.
 - 5. Provide vinyl covered tackboard over solid and continuous substrate of plywood, plaster or minimum 5/8" type X gypsum board.
 - 6. Panel sizes: 8, 9, or 10 foot lengths; depending on ceiling ht; width of 48-inches minimum cut panel size in any direction. No horizontal joints will be acceptable. Panels shall be sized to run continuous from floor to ceiling or wainscot height as shown on the Drawings.

PART 3 - EXECUTION

3.01 INSPECTION

- A. Installer must examine substrates and conditions under which vinyl covered tackboard is to be installed and must notify the Contractor in writing of conditions detrimental to proper and timely completion of work. Do not proceed with work until unsatisfactory conditions have been corrected in manner acceptable to Installer.

3.02 PREPARATION

- A. Acclimatize board materials by removing from packaging in area of installation not less than 24 hours before application.

- B. Remove switchplates, wall plates, and surface-mounted fixtures in areas where board is to be applied. Where not specifically identified, provide mud rings at all existing wall plate locations extend existing device flush with finish surface of vinyl.

3.03 INSTALLATION

- A. All vinyl wall covering shall be factory installed on ½" thick tackboard.
- B. Corners of edge moldings around doors and windows shall be carefully cut at 45 degrees to provide tight fitting mitered corners. Sloppy corners will not be permitted. Putty fill of gaps is not acceptable.
- C. Provide "corner moldings" at outside corners.
- D. Apply glue to backside of panels or to substrate in a uniform coat completely covering entire surface (combed trowel preferred). Provide all temporary bracing required to ensure that vinyl covered tackboard is totally adhere to underlayment.
- E. Cut the fiberboard backing, where required, so that the vinyl covering is left longer than the backing. Wrap the vinyl around the cut surface and glue. All finished panels shall have all edges wrapped.
- F. Where vinyl covered tackboard is to be covered with rubber base the maximum "gap" between concrete slab and tackboard shall be 3/8" the minimum "gap" shall be 1/8" (to prevent moisture from wicking up into tackboard). Provide non porous (metal or hardwood) backing for resilient base in resulting gap.
- G. Tackboard shall extend behind all new markerboards and new equipment items including fire extinguishers/cabinets, safety fire blanket cabinets, pencil sharpeners, and other miscellaneous equipment items. Tackboard shall not extend behind new or relocated existing cabinet work that is part of this contract unless otherwise indicated on the Drawings. Tackboard shall butt tight to all casework and other items when not running continuous behind.

3.04 ADJUST AND CLEAN

- A. Replace removed plates and fixtures; verify cut edges of wall coverings are completely concealed.
- B. Remove surplus materials, rubbish, and debris resulting from wall covering installation upon completion of work, and leave areas of installation in neat, clean condition.
- C. Remove and re-glue any panels which show movement when "pushed" toward wall plain.

END OF SECTION

**SECTION 10 00 00
SPECIALTIES**

PART 1 – GENERAL

1.01 SECTION INCLUDES:

- A. Provide and install specialty and built-in items as indicated on the Drawings and specified here.
 - 1. Preparation Room Dishwasher.
 - 2. Prep Room Peg Boards.
 - 3. Projector Screens.
- B. Provide miscellaneous, and incidental items under the work of this section for all items indicated on the Drawings but not specifically addressed in other sections or not necessarily scheduled herein.

1.02 RELATED SECTIONS:

- A. Section 00 70 00: General Conditions.
- B. Section 06 41 16: Plastic Laminate Clad Architectural Cabinets.
- C. Division 22: Plumbing.
- D. Division 26: Electrical.

1.03 STANDARDS:

- A. Individual items or assemblies scheduled or as indicated on the Drawings, shall conform to respective industry and governmental standards.

1.04 QUALITY ASSURANCE:

- A. Installation of items or assemblies shall be by personnel thoroughly trained and experienced in the required skills and completely familiar with respective manufacturer's methods of installation.
- B. CBC, California Building Code - 2010 Edition, as amended.

1.05 SUBMITTALS:

- A. Before any specialty items are delivered to the job site, submit Shop Drawings and catalog cuts with complete product data in accordance with Section 00 70 00 and Section 01 33 00. Show all details of installation and assembly, all requirements for work by other trades, and all finish colors available from the selected manufacturer in the quality specified.

1.06 DELIVERY, STORAGE AND HANDLING:

- A. Deliver undamaged products or materials to site in manufacturer's sealed containers or wrappings with legends intact. Store on site secure from weather, soil and physical damage.

PART 2 – PRODUCTS

2.01 GENERAL:

- A. All items or assemblies shall be as scheduled in Article 3.05 of this Section, or approved equal items as set forth in Section 00 70 00, covering submission and review of substitutions.
- B. Items which are not scheduled herein and not addressed in other Sections, but are noted or otherwise indicated on the Drawings, will be clarified by the Architect prior to or after the Bid upon the Contractor's request. Such clarification will not be considered as grounds for an increase to the contract cost or to the contract time when such a clarification is requested after the Bid.

PART 3 – EXECUTION

3.01 INSPECTION:

- A. Coordinate with other trades as required to ensure proper and adequate provision in framing and wall finish for the installation of the selected specialties in the correct locations.
- B. Prior to installation, carefully inspect and verify that the installed work of other trades is complete to the point where this installation may properly commence.
- C. Verify that specified items can be installed in accordance with the approved design.
- D. In the event of discrepancy, immediately notify Architect. Do not proceed in discrepant areas until discrepancies have been fully resolved.
- E. Upon completion of installation, and as a condition of acceptance, visually inspect the entire work of this Section, adjust all components for proper alignment and use, and touch up all abrasions and scratches to make them completely invisible.

3.02 INSTALLATION:

- A. Install all specialty items where indicated on the Drawings and in full accordance with all pertinent regulations and the manufacturer's recommendations, anchoring all components firmly in place for long life under hard use.

3.03 PROTECTION:

- A. Protect work and materials of this Section prior to and during installation, and protect the installed work and materials of other trades.
- B. In the event of damage, make all repairs and replacements necessary to the satisfaction of the Architect at no additional cost to the Owner.

3.04 CLEAN UP:

- A. Keep building and premises free from accumulated waste materials, rubbish and debris resulting from Work herein. Upon completion of work, remove tools, appliances, surplus materials, waste materials, rubbish, debris and accessory items used in or resulting from installation, and legally dispose of off site.

3.05 SCHEDULE OF MISCELLANEOUS SPECIALTIES:

- A. **Under-Counter Dishwasher:** GE Tall Tub Built-In Dishwasher, Model No. GLDA690PBB or equal. Model must be sized to fit under restricted accessible counter height. Color to be selected from full line of standard colors.
- B. **Prep Room Pegboard:** Epoxy resin pegboard (color = black) with polypropylene pegs (color = grey) as manufactured by Durcon, Model No. 2030 or equal with minimum 32 pegs. Provide optional 2" wide stainless steel drip tray and drain hose.
- C. **Projection Screen:**
1. Projection Screen shall conform to the following Da-Lite product characteristics:
 - a. Da-Lite Model "C", roller-type screen, screen size shall be minimum 70" H. x 70" W. Wall mount type for surface installation.
 - b. Screens shall have Matte White surfaces with masking borders on flame retardant and mildew resistant fiberglass fabric, mounted on 3 inch diameter ball bearing rigid steel spring roller. Fabric shall be permanently attached to roller by metal clips on fabric edge being forced into groove on roller. There shall be a clip every 3 inches along the fabric edge and double clips shall be used on the ends. Screen shall have 22 gauge steel case with flat black design finished with baked enamel, and heavy duty plated steel case and caps concealing roller ends with steel inner plates to support roller and provide added case strength. End caps shall form sturdy brackets for wall installations. Bottom of screen shall be formed into pocket holding tubular metal slat. An extruded aluminum saddle with plate steel sized and designed to receive the end of a pull-down pole. The ends of the slat shall be protected by heavy-duty plastic caps. Metal bumper stops padded with sponge rubber shall be built into the case to prevent slat wedging inside of case.
 - c. Furnish one (1) pull down pole for each projection screen. Pole shall be made of aluminum and shall be approximately four (4) feet long. Pole shall have hook end for engaging pull down ring attached to screen.
 - d. Furnish one (1) wall mounting bracket equal to Da-Lite Model No. 11 and shall be securely anchored to surface applied wood block per Architectural drawings. Mount at height indicated on Drawings.

END OF SECTION

**SECTION 10 11 00
VISUAL DISPLAY UNITS**

The General Conditions, Supplementary Conditions and Division 1 General Requirements are hereby made a part of this Section as fully as if repeated herein.

PART 1 - GENERAL

1.01 SCOPE:

- A. Provide all material, labor, equipment services necessary to furnish and install Visual display boards. Accessories and other related items necessary to complete the Project as indicated by the Contract Documents unless specifically excluded.
- B. Related Work Specified Elsewhere:
 - 1. Section 06 10 00 Rough Carpentry.
 - 2. Section 06 20 00 Finish Carpentry.
 - 3. Section 09 21 16 Gypsum Board Assemblies.
 - 4. Section 09 92 16 Vinyl-Coated Fabric Wall Coverings.

1.02 STANDARDS:

- A. In accordance with Section 01-080 CODES AND STANDARDS and the following:
 - 1. AIES - American and Illuminating Engineering Society.

1.03 SUBMITTALS:

- A. Comply with requirements of Shop Drawings, Product Data and Samples Section 01 33 00.

PART 2 – PRODUCTS

2.01 HORIZONTAL SLIDING DRY MARKER BOARDS:

- A. Dry marker boards shall be Nelson Adams H1 series Horizontal Sliding Panels, Claridge HS2 Horizontal Sliding Dry-Erase Boards, or approved equal. Boards shall be porcelain enamel coated, minimum 22 gauge, one-piece sheet steel and shall be trimmed out in a clear anodized aluminum frame, color as selected by Architect from manufacturer's full range of standard colors.
- B. Sliding configuration shall be one 8'-0" wide single sliding unit over fixed 16'-0" wide back unit.
- C. Marker trough shall be equal to Claridge No. 264.
- D. Map rail shall be equal to Claridge No. 51, with cork insert, size to match marker board thickness with.
- E. Perimeter trim shall be equal to Claridge No. 170, size to match marker board thickness.
- F. Provide all miscellaneous and incidental accessories as required for a complete and proper installation.

2.02 FABRICATION:

- A. Laminate facing sheet and backing sheet to core material under pressure with manufacturer's recommended flexible, waterproof adhesive.
- B. Assembly: Provide factory-assembles visual display board units except where field-assembles units are required.
 - 1. Make joints only where total length exceeds maximum manufactured length. Fabricate with the minimum number of joints, balanced around the center of the board, as acceptable to the Architect.
 - 2. Provide the manufacturer's standard vertical joint system between abutting sections of display boards.
- C. Minimum lengths shall be 16 feet, in one piece, or as indicated on Drawings.

2.03 FINISHES:

- A. Comply with NAAMM "Metal Finishes Manual" for recommendations relative to application and designations of finishes.

PART 3 – EXECUTION

3.01 INSTALLATION:

- A. Deliver factory-built visual display board units completely assembled in one piece without joints, wherever possible. Where dimensions exceed panel size, provide 2 or more pieces of equal length as acceptable to the Architect. When overall dimensions require delivery in separate units, prefit components at the factory, disassemble for delivery, and make final joints at the site. Use splines at joints to maintain surface alignment.
- B. Install units in locations and at mounting heights indicated and in accordance with the manufacturer's instructions. Keep perimeter lines straight, plumb, and level. Provide grounds, clips, backing materials, adhesives, brackets, anchors, trim, and accessories necessary for a complete installation.
- C. Coordinate with other sections for metal or wood backing.
 - 1. Contractor to coordinate all blocking required for sizes indicated on Drawings prior to enclosing stud cavities. See Rough Carpentry 06100.
- D. Install boards top and bottom with wall clips screwed to backing at 24 inches on center at blocking.

3.02 ADJUST AND CLEAN:

- A. Verify that accessories required for each unit have been properly installed and that operating units function properly.
- B. Clean units in accordance with the manufacturer's instructions.

END OF SECTION

**SECTION 10 14 00
SIGNAGE**

PART 1 – GENERAL

1.01 SECTION INCLUDES

- A. Provision and installation of interior and exterior room identification signs, geometric restroom signs and interior and exterior directional and informational signs including signs for accessible features and regulatory signs.
- B. Melamine signs
- C. Decals
- D. Support posts

1.02 RELATED SECTIONS (List is for the Contractor's Convenience and May Not Be Complete.)

- A. Section 00 70 00: General Conditions
- B. Section 06 10 00: Rough Carpentry
- C. Section 08 10 00: Metal Doors and Frames
- D. Section 06 20 00: Wood Doors
- E. Section 09 90 00: Painting and Coatings.

1.03 RELATED CODES AND STANDARDS

- A. Accessible signs shall conform with the following requirements as indicated:
 - 1. California Building Code (CBC Title 24, 2010 CBC).
 - 2. ADA Accessibility Guidelines (ADAAG, latest adopted edition).
 - 3. Contracted Grade 2 Braille shall be used whenever Braille symbols are specifically required (CBC Section 1117B.5.6).
 - 4. Means of Egress Identification: CBC 1117.B.5.1.
 - 5. Tactile Exit Signs: CBC 1011.3.
 - 6. Restroom Identification Symbols: CBC 1115B.6.
 - 7. Signs and Identification: CBC 1117B.5.
 - 8. International Symbol of Accessibility: CBC 1117B.5.8.1.
 - 9. Identification Signs: CBC 1117B.5.1.1.
 - 10. Direction and Information Signs: CBC 1117B.5.1.2.

11. Accessibilities Signs: CBC 1117B.5.1.3.
12. Finish and Contrast: CBC 1117B.5.2.
13. Proportions: CBC 1117B.5.3.
14. Character Height: CBC 1117B.5.4.
15. Raised Characters and Pictorial Symbol Signs: CBC 1117B.5.5.
16. Braille: CBC 1117B.5.6.
17. Mounting Height and Location: CBC 1117B.5.7.
18. Symbols of Accessibility: CBC 1117B.5.8.
19. Color of Symbol: CBC 1117B.5.8.1.1.
20. Entrance Signs: CBC 1117B.5.8.1.2.
21. Signage: ADAAG 4.30.
22. Facility Accessibility: CBC 1114B.

1.04 SUBMITTALS

- A. Submit manufacturer's technical data and installation for each type of sign required.
- B. Submit shop drawings listing sign size, type style and letter heights and construction detail.
- C. Submit one full size sample sign with tactile characters, Braille and subsurface text or pictogram to demonstrate fabrication technique and Braille measurements which shall be used on proposed project.
- D. Submit samples of background colors, character colors, and one inch high print outs of "I," "O" and "X" from proposed type styles. Indicate which type styles shall be used for required tactile characters and for required visual characters.
- E. Submit proposed sign schedule to comply with scoping requirements above.
- F. Submit under provisions of Section 01 33 00.
- G. All signage shall be designed and constructed to comply with signage specifications and drawings.

1.05 QUALITY ASSURANCE, MATERIALS AND FABRICATION TECHNIQUES

A. QUALITY ASSURANCE

1. Manufacturers shall submit 3 references showing products for projects completed within the last 6 years. Both tactile and non-tactile signage shall be included in the work.

2. Manufacture's Two-Year Warranties
3. Contractor shall provide labor and materials to repair or replace defective signs as directed by Owner. Defects shall include:
 - a. Tactile characters and/or Braille dots which come off or are removed.
 - b. Discoloration, wear and scratching off of the surface color.
 - c. All signs and sign components, except for damage by mishandling by Owner, including installation by Owner, or vandalism.

1.06 PRODUCT DELIVERY, STORAGE AND HANDLING

- A. Deliver to project site in manufacturer's original, unopened and undamaged packaging. Store in original packaging under protective cover and protect from damage. Handle materials in such a manner as to prevent damage to products or finishes.

PART 2 – PRODUCTS

2.01 MATERIALS

- A. Sign Material
 1. Room Identification and Directional Signs: Nelson-Harkins Sign TS450 or equal. Sign size shall be minimum 4 inch by 4 inch by .125 inch thick. Sign shall be made of melamine material with photoblasted raised image graphic, color to be selected from manufacturer's full line of standard colors. Provide mounting holes at each corner.
 2. Parking lot signs shall be .080 aluminum with white reflective graphics.
 3. Restroom gender use sign shall be a total of ¼" thick polymer or laminate acrylic.
 - a. Pictogram and text shall be white on a medium blue background, or medium blue on a white background to provide a minimum of a 70% contrast with mounting surface.
 - b. Blue shall be equal to Federal Blue No. 15980 in Federal Specifications 595B.
- B. Fasteners: One way tamper resistant screw # 90090A 155 (1.25" minimum, 1" minimum embedment into wall) for wood, masonry or concrete application and self drilling tamper resistant pan head pin in head torx (1") #92970A for metal application with fastener anchors as appropriate for wall material.
- C. Decals shall be a heavy gauge sticker.
- D. Parking stall identification signs shall be reflective.
- E. Refer to signage drawings for additional signage information.
 1. Sign types shall be as stipulated in Specification Section 10 14 00 unless otherwise shown on the Drawings.

2. Sign sizes shall be as stipulated in Specification Section 10 14 00 unless otherwise shown on the Drawings.
 3. Sign text and numeral heights shall be as stipulated in Specification Section 10 14 00 unless otherwise shown on the Drawings.
 4. Signage text shall be as shown on the Drawings.
 5. Other signage symbols, pictograms, etc. shall be as shown on the Drawings.
- F. No substitution of material or design shall be permitted.

2.02 SUBSTRATE

- A. Interior plaques shall have eased or rounded edges and corners.
- B. Exterior plaques shall have eased or rounded edges.
- C. Pole or post mounted signs, projecting signs and aluminum or other metal plaques or signs shall have eased or rounded edges and a minimum 0.125 inch corner radius.

2.03 GENERAL

- A. Non-glare (non-reflective) materials shall be used for all signs which identify, direct to, or give information about facilities and their use.
 1. Exception: Parking, traffic signs, and exterior safety signs may use reflective materials. Identification signs for accessible parking spaces shall use reflective materials for graphics.
- B. Characters shall have a minimum of 70 percent contrast with their backgrounds on all signs which identify, direct to, or give information about facilities and their use.
- C. Characters on all signs which identify, direct to, or give information about facilities and their use shall comply with CBC 1117B.5.3. Characters shall have a width-to-height ratio of between 3:5 and 1:1 and a stroke width-to-height ratio of between 1:5 and 1:10.
- D. Type styles of characters on all signs which identify, direct to, or give information about facilities and their use shall not be italic, oblique, or decorative in style.
- E. Non-tactile characters (letters, numbers and symbols) shall be Helvetica Regular
 1. Characters shall be uppercase unless otherwise shown on Drawings.
 2. Upper case letters shall be 1 inch high (unless otherwise shown on Drawings, maximum 1 1/4 inch high).
 3. Height of lower case letters (where shown on Drawings) shall be proportional to height of upper case letter.

2.04 TACTILE CHARACTERS

- A. Characters required to be tactile shall be Helvetica Regular.
 - 1. Characters shall be raised 1/32 inch minimum and a maximum of 1/16 inch from the background. Raised tactile characters shall have beveled edges (2010 CBC). Regular uppercase and lowercase characters and numerals accompanied by corresponding Grade 2 Braille.
 - 2. Characters shall be uppercase unless otherwise shown on Drawings. Signs shall have tactile characters where shown on Drawings.
 - 3. Upper case tactile letters shall be 1 inch high (unless otherwise shown on Drawings, maximum 1-1/4 inch high) embossed text and numerals that comply with CBC 1117.B.5.5. Vertical dimension of lower case letters shall be proportional to height of upper case letters.
 - 4. Exception: Characters required by code to exceed 1 1/4 inches, such as elevator hoistway characters, shall not exceed 2 inches in height. Characters on elevator control panels shall not be less than 5/8 inches high.
- B. A minimum of 1/8" space between the top surfaces of adjacent characters measuring between the two closest points shall be provided.
- C. Font proportions that comply with CBC 1117B.5.3.
- D. Drawing Coordination: Sign size, text, mounting locations requirements and other requirements shall be as stipulated in this Specification Section unless other shown on Drawings.

2.05 BRAILLE

- A. Braille text shall comply with CBC 1117B.5.6.
- B. Braille on metal signs shall be embossed domed California Braille. All Braille shall be fabricated by a method which produces a rounded or domed dot shape. All Braille dots shall be solid or filled from behind so they cannot be crushed or indented.
- C. Braille dot, cell spacing and dot height shall follow specifications as per CBC 1117B.5.6.
- D. Dots shall be 1/10 inch on centers in each cell with 2/10 inch space between cells, measured from the second column of dots in the first cell to the first column of dots in the second cell. Dots shall be raised a minimum of 1/40 inch above the background surface. Other Braille measurements shall comply with CBC 1117B.5.6.
- E. There shall be no Braille indication of capital letters except for proper names, individual letters or acronyms, or beginnings of sentences.
- F. Braille shall be centered directly below raised print characters.
- G. Braille shall be located on the sign 3/8 inch below the corresponding tactile characters, flush left or centered to the characters depending on the sign layout. (CBC 1117B.5.5.4)
- H. Spacing between Braille and raised characters should be between 3/8" to 1/2", but not closer than 3/8".

2.06 NON-TACTILE GRAPHICS AND TEXT

- A. Non-tactile graphics/pictogram and text shall screen printed on the surface and complying with Paragraph 2.01.A.1.a of this Specification Section.
- B. Identifying pictograms shall be located above the tactile text in a clear, six inch high field.
- C. Non-tactile text shall be upper case and one inch high (unless otherwise shown on Drawings), and shall comply with CBC 1117B.5.2 through 1117B.5.4.

2.07 MISCELLANEOUS

- A. Furnish all items required for the proper installation of all signage including but not limited to tamper resistant fasteners, adhesives, sealants, metal sleeve spacers, etc.

2.08 SITE SIGNS: (See Drawings for locations, post and footing design and locations, typical):

- A. Accessible Parking Stall Sign (See Drawings for locations):
 - 1. Fabricate with metal panel for each accessible parking stall as indicated on the Drawings. The sign shall display the International Symbol of Accessibility (reflectorized); text shall occur below the symbol and read "MINIMUM FINE \$250". The bottom of the regular accessible stall sign shall be mounted 80" above the finish grade. Color shall be white text on blue field. See Drawings for additional information.
 - a. At wall mounted application, use tamper resistant concrete screws in pre-drilled holes. See Drawings for additional information.
 - b. At fence mounted application, use metal rings to secure to fencing fabric. See Drawings for additional information.
- B. Van Accessible Parking Stall Sign (See Drawings for locations):
 - 1. Same as "Accessible Parking Stall Sign" described above. Install above new "Van Accessible" sign. Color shall be white text on blue field. See Drawings for additional information.
 - a. At wall mounted application, use tamper resistant concrete screws in pre-drilled holes. See Drawings for additional information.
 - b. At fence mounted application, use metal rings to secure to fencing fabric. See Drawings for additional information.
- C. Accessible Parking Entry Sign (See Drawings for locations):
 - 1. Fabricate with a single post and metal panel at location indicated on the Drawings. The sign shall display the text as described on the Drawings. The bottom of the regular accessible stall sign shall be mounted 80" above the finish grade. Color shall be white text on blue field. See Drawings for additional information.

PART 3 – EXECUTION

3.01 GENERAL

- A. Signs shall be installed with edges horizontal and vertical and face plumb.
- B. Install signs with tamper resistant screws and anchors at all wall conditions except glass.
- C. Screw length shall be sufficient for minimum 1 inch embedment.
- D. Signs mounted onto glass:
 - 1. Sign shall be attached to glass with clear silicone adhesive designed to secure sign material to glass (double stick tape with cushion is not permitted). Contractor shall apply sealant around perimeter of sign.
 - 2. Where interior and exterior signs are to be mounted, signs shall be the same size (the larger sign size shall dictate the size of the smaller sign) and located "back-to-back".
 - 3. Where only an interior or exterior sign is mounted, a "blank sign" (the same size as the sign) shall be installed and located "back-to-back".
- E. The Contractor is solely responsible for the identification of the material onto which signs are to be mounted. The Contractor shall furnish and install all materials necessary for the proper installation of each sign.
- F. Contractor shall notify the Architect of any conflicts between the Drawings, Specifications and the requirements of the CBC and ADA prior to the submission of the Bid Form. No increase of the Contract Sum and no extension of the Contract Time shall be granted for the resolution of CBC, ADA and Contract Documents conflicts.
- G. Permanent identification signs for rooms or spaces shall be installed on the wall adjacent to the latch side of the door and at 60 inches centered above the finish floor or ground. (CBC 1117B.5.7).

3.02 ADJUST AND CLEAN

- A. Clean and Touch-up: Remove all packing and protection blemishes and thoroughly clean and polish all finish surfaces. Restore any marred or abraded surfaces to their original condition by touching up in accordance with the manufacturer's recommendations. Touch-up shall not be obvious.
- B. Defective Work: Remove and replace all defective work which cannot be properly repaired, cleaned or touched-up with no additional cost to the owner.
- C. Protect installed work during the construction period to prevent abuse and damage.

3.03 CLEAN-UP

- A. Upon completion of the work of this section, remove all surplus materials, rubbish and debris from the premises.

END OF SECTION

**SECTION 10 28 00
TOILET AND BATH ACCESSORIES**

PART 1 – GENERAL

1.01 SECTION INCLUDES

- A. Toilet accessories.
- B. Attachment hardware.

1.02 RELATED SECTIONS

- A. Section 00 70 00: General Conditions.
- B. Section 06 10 00: Rough Carpentry In wall framing and backing for support of accessories.
- C. Section 09 21 16: Gypsum Board Assemblies.

1.03 REFERENCES

- A. ASTM A167-99(2009) - Stainless and Heat-Resisting Chromium-Nickel Steel Plate, Sheet and Strip.
- B. ASTM A269-08 - Seamless and Welded Austenitic Stainless Steel Tubing for General Service.

1.04 KEYING

- A. Master key all accessories.

1.05 REGULATORY REQUIREMENTS

- A. Conform to applicable code for installing work in conformance with Title 24 Accessibility Requirements.

1.06 SUBMITTALS

- A. Product Data: Manufacturer's product data and installation instructions for each toilet accessory.
- B. Samples: Full-size sample of each toilet accessory item. Acceptable samples will be returned and may be used in the work.
- C. Setting Drawings: Furnish setting drawings, templates, instructions, and direction for installation of anchorage devices and cut-out requirements in other work.

1.07 SEQUENCING AND SCHEDULING

- A. Coordinate the work of this Section with the placement of internal wall reinforcement and reinforcement of toilet partitions to receive anchor attachments.

1.08 QUALITY ASSURANCE

- A. Manufacturer: Provide products of same manufacturer for each type of accessory unit unless otherwise approved by the Architect.

1.09 PROJECT CONDITIONS

- A. Coordinate accessory locations, installation, and sequencing with other work to avoid interference and to assure proper installation, operation, adjustment, cleaning, and servicing.

PART 2 – PRODUCTS

2.01 MANUFACTURERS

- A. Bobrick.
- B. Bradley.
- C. IMPACT Products, Inc. (419) 841-2891.
- D. Or approved equal.

2.02 MATERIALS

- A. Stainless Steel Sheet: ASTM A167-99 (2009), Type 304.
- B. Tubing: ASTM A269-08, stainless steel.
- C. Fasteners, Screws, and Bolts: Hot dip galvanized, tamperproof.
- D. Expansion Shields: Fiber, lead, or rubber as recommended by accessory manufacturer for component and substrate.

2.03 FABRICATION

- A. The following model numbers are Bobrick numbers and establish a quality level:
 - 1. Toilet Paper Dispenser:
 - a. Accessible Stall with stud wall construction: B-3888; 2-roll, semi-recessed, tumbler lock.
 - 2. Toilet Seat Cover Dispenser: B-221; surface mounted, capacity for 250 single or half-fold covers (staff toilet rooms only)
 - 3. Paper Towel Dispenser: Georgia Pacific, Model No. 54338, surface mounted, tumbler lock, accepts standard core rolls ranging from 7" to 8" wide and up to 8" in diameter.
 - 4. Liquid Soap Dispenser: Impact Products, Model No. 9347, surface mounted, 46 oz. capacity
 - 5. Mirror: B-265, size -18"x30".
 - 6. Grab Bars: B-6806 Series; snap flange covers, configurations and sizes as indicated on

drawings.

- a. At accessible toilet stalls: 42" long on back wall, 48" long on side wall or as required by drawings.
- b. Mount to solid wood blocking.
- c. At locations where grab bars are mounted to partition system, provide Bobrick Grab Bar Anchors for Toilet Partitions, Series 258 backing plate.

B. Assemblies:

1. Weld and grind smooth joints of fabricated components.
2. Form exposed surfaces from single sheet of stock, free of joints.
3. Form surfaces flat without distortion. Maintain flat surfaces without scratches or dents.
4. Shop assemble components and package complete with anchors and fittings.
5. Provide steel anchor plates, adapters, and anchor components for installation.
6. Hot dip galvanize exposed and painted ferrous metal and fastening devices.

2.04 FACTORY FINISHING

- A. Satin Finish, Stainless Steel: No. 4 satin luster finish.

PART 3 – EXECUTION

3.01 EXAMINATION

- A. Verify that site conditions are ready to receive work and dimensions are as instructed by the manufacturer.
- B. Beginning of installation means acceptance of existing conditions.

3.02 PREPARATION

- A. Deliver inserts and rough-in frames to site at appropriate time for building-in.
- B. Provide templates and rough-in measurements as required.
- C. Verify exact location of accessories for installation.

3.03 INSTALLATION

- A. Prior to mounting any accessories, Contractor shall provide dimensionally correct cardboard cutouts of all accessories. Contractor shall then walk each toilet room area with District to place all accessories in acceptable locations. This shall take place PRIOR to installing new gypsum board as backing for accessories needs to be installed.
- B. Install fixtures, accessories and items in full compliance with CBC(Latest Edition) requirements

and per manufacturer's recommendations.

- C. Install plumb and level, securely and rigidly anchored to substrate. Use vandal resistant fasteners where exposed.

3.04 ADJUSTING AND CLEANING

- A. Adjust toilet accessories for proper operation and verify that mechanisms function smoothly. Replace damaged or defective items.
- B. Clean and polish exposed surfaces of accessories in accordance with manufacturer's recommendations after removing temporary labels and protective coatings.

END OF SECTION

**SECTION 22 00 50
BASIC PLUMBING MATERIALS AND METHODS**

PART 1 - GENERAL

1.01 SECTION INCLUDES

- A. Electric motors.
- B. Motor starters.
- C. Valves and fittings.
- D. Strainers.
- E. Valve boxes.
- F. Gauges.
- G. Thermometers.
- H. Access Doors.
- I. Expansion loops.
- J. Flexible joints.
- K. Insulation.

1.02 RELATED DOCUMENTS

- A. Drawings and general provisions of the Contract, including General and Supplementary Conditions and Division 01 Specification Sections, apply to this Section.
- B. This Section is a part of each Division 22 Section.

1.03 ADDITIONAL REQUIREMENTS

- A. Furnish and install any incidental work not shown or specified which is necessary to provide a complete and workable system.
- B. Make all temporary connections required to maintain services during the course of this Contract without additional cost to the Owner. Notify the Owner seven days in advance before disturbing any service.

1.04 REFERENCED STANDARDS

- A. Where material or equipment is specified to conform to referenced standards, it shall be assumed that the most recent edition of the standard in effect at the time of bid shall be used.
 - 1. CSA – Canadian Standards Association International
 - 2. ANSI - American National Standards Institute

3. ASTM - American Society for Testing and Materials
4. CCR - California Code of Regulations
 - a. Title 8 - Division of Industrial Safety, Subchapter 7; General Industry Safety Orders, Articles 31 through 36
5. NCPWB - National Certified Pipe Welding Bureau
6. CEC - California Electrical Code
7. NEMA - National Electrical Manufacturers' Association
8. NFPA - National Fire Protection Association
9. OSHA - Occupational Safety and Health Act
10. UL - Underwriters' Laboratories, Inc.

1.05 DRAWINGS

- A. Examine Contract Documents prior to bidding of work and report discrepancies in writing to Architect.
- B. Contractor shall visit Project site and examine existing conditions in order to become familiar with Project scope. Verify dimensions shown on Drawings at Project site. Bring discrepancies to the attention of Architect. Failure to examine Project site shall not constitute basis for claims for additional work because of lack of knowledge or location of hidden conditions that affect Project scope.
- C. Drawings showing location of equipment and materials are diagrammatic and job conditions will not always permit installation in location shown. The Plumbing Drawings show general arrangement of equipment and materials, etc., and shall be followed as closely as existing conditions, actual building construction, and work of other trades permit.
 1. Architectural and Structural Drawings shall be considered part of the Work. These Drawings furnish Contractor with information relating to design and construction of the Project. Architectural Drawings take precedence over Plumbing Drawings.
 2. Because of the small scale of Plumbing Drawings, not all offsets, fittings, and accessories required are shown. Investigate structural and finish conditions affecting the Work and arrange Work accordingly. Provide offsets, fittings, and accessories required to meet conditions. Inform Architect immediately when job conditions do not permit installation of equipment and materials in the locations shown. Obtain the Architects approval prior to relocation of equipment and materials.
 3. Relocate equipment and materials installed without prior approval of the Architect. Remove and relocate equipment and materials at Contractors' expense upon Architects' direction.
 4. Minor changes in locations of equipment, piping, ducts, etc., from locations shown shall be made when directed by the Architect at no additional cost to the Owner providing such

change is ordered before such items of work, or work directly connected to same are installed and providing no additional material is required.

- D. Execute work mentioned in Specifications and not shown on Drawings, or vice versa, the same as if specifically mentioned or shown in both.

1.06 REQUIREMENTS OF REGULATORY AGENCIES

- A. The publications listed below form part of this specification; comply with provisions of these publications except as otherwise shown or specified.
 - 1. California Electrical Code, 2010
 - 2. National Fire Protection Association
 - 3. CAL-OSHA
 - 4. California Code of Regulations, Title 24
 - 5. Occupational Safety and Health Administration
 - 6. California State Fire Marshal, Title 19 CCR
 - 7. California Building Code, 2010
 - 8. California Energy Code, 2010
 - 9. California Fire Code, 2010
 - 10. California Mechanical Code, 2010
 - 11. California Plumbing Code, 2010
 - 12. California Green Building Standards Code, 2010
 - 13. California Health and Safety Code
 - 14. Other applicable state laws
- B. Nothing in Drawings or specifications shall be construed to permit work not conforming to these codes, or to requirements of authorities having jurisdiction. It is not the intent of Drawings or specifications to repeat requirements of codes except where necessary for clarity.
- C. Comply with State of California 2010 Energy Code for all systems, equipment, and construction.
- D. When Contract Documents differ from governing codes, furnish and install larger size or higher standards called for without extra charge.
- E. No material installed as part of this Work shall contain asbestos.

1.07 FEES AND PERMITS

- A. Obtain and pay for all permits and service required in installation of this work; arrange for required inspections and secure approvals from authorities having jurisdiction. Comply with requirements of Division 01.
- B. Arrange for utility connections and pay charges incurred, including excess service charges.

1.08 UTILITY CONNECTIONS

- A. Bear the cost of construction related to utility services, from point of connection to utility services shown on Contract Documents. This includes piping, excavation, backfill, meters, boxes, check valves, backflow prevention devices, general service valves, concrete work, and the like, whether or not Work is performed by Contractor, local water/sanitation district, public utility, other governmental agencies or agencies' assigns.

1.09 FRAMING, CUTTING AND PATCHING

- A. Special framing, recesses, chases and backing for Work of this Section, unless otherwise specified, are covered under other Specification Sections.
- B. Contractor is responsible for placement of pipe sleeves, hangers, inserts, supports, and location of openings for the Work.
- C. Cutting, patching, and repairing of existing construction to permit installation of equipment, and materials is the responsibility of Contractor. Repair or replace damage to existing work with skilled mechanics for each trade.
- D. Cut existing concrete construction with a concrete saw. Do not utilize pneumatic devices.
- E. Core openings through existing construction for passage of new piping and conduits. Cut holes of minimum diameter to suit size of pipe and associated insulation installed. Coordinate with building structure, and obtain Structural Engineer's approval prior to coring through existing construction.

1.10 SUBMITTALS

- A. Provide submittal of materials proposed for use as part of this Project. Product names in Specifications and on Drawings are used as standards of quality. Furnish standard items on specified equipment at no extra cost to the Contract regardless of disposition of submittal data. Other materials or methods shall not be used unless approved in writing by Architect. Architect's review will be required even though "or equal" or synonymous terms are used. Refer to Division 01 for complete instructions.
 - 1. Partial or incomplete submittals will not be considered.
 - 2. Quantities are Contractor's responsibility and will not be reviewed.
 - 3. Provide materials of the same brand or manufacturer for each class of equipment or material.

4. Identify each item by manufacturer, brand, trade name, number, size, rating, or other data necessary to properly identify and review materials and equipment. Words "as specified" are not sufficient identification.
 5. Identify each submittal item by reference to items' Specification Section number and paragraph, by Drawing and detail number, and by unit tag number.
 6. Organize submittals in same sequence as in Specification Sections.
 7. Show physical arrangement, construction details, finishes, materials used in fabrications, provisions for piping entrance, access requirements for installation and maintenance, physical size, mechanical characteristics, foundation and support details, and weight.
 - a. Submit Shop Drawings, performance curves, and other pertinent data, showing size and capacity of proposed materials.
 - b. Specifically indicate, by drawn detail or note, that equipment complies with each specifically stated requirement of Contract Documents.
 - c. Drawings shall be drawn to scale and dimensioned (except schematic diagrams). Drawings may be prepared by vendor but must be submitted as instruments of Contractor, thoroughly checked and signed by Contractor before submission to Architect for review.
 - d. Catalog cuts and published material may be included with supplemental scaled drawings.
- B. Review of submittals will be only for general conformance with design concept and general compliance with information given in Contract Documents. Review will not include quantities, dimensions, weights or gauges, fabrication processes, construction methods, coordination with work of other trades, or construction safety precautions, which are sole responsibility of Contractor. Review of a component of an assembly does not indicate acceptance of an assembly. Deviations from Contract Documents not clearly identified by Contractor are Contractor's responsibility and will not be reviewed by Architect.
- C. Within reasonable time after award of contract and in ample time to avoid delay of construction, submit to Architect Shop Drawings or submittals on all items of equipment and materials provided. Provide submittal in at least seven copies and in complete package.
1. Shop Drawings and submittals shall include Specification Section, Paragraph number, and Drawing unit symbol or detail number for reference. Organize submittals into booklets for each Specification section and submit in loose-leaf binders with index. Deviations from the Contract Documents shall be prominently displayed in the front of the submittal package and referenced to the applicable Contract requirement.
- D. Furnish to the Project Inspector complete installation instructions on material and equipment before starting installation.
- E. Product Data for California Green Building Standards Code Compliance: For adhesives and sealants, including primers, documentation of compliance including printed statement of VOC content and chemical components.
- F. Provide product data for insulation products, including insulation, insulation facings, jackets, adhesives, sealants, and coatings, indicating compliance with requirement that these products

contain less than 0.1 percent (by mass) polybrominated diphenyl ethers (PBDEs) in penta, octa, or deca formulations.

- G. Pipe, pipe or plumbing fittings, fixtures, solder and flux installed in a system providing water for human consumption shall comply with lead free requirements of the California Health and Safety Code Section 116875. Provide submittal information for products third-party certified by an approved laboratory as complying with California Health and Safety Code Section 116875.
- H. Delegated-Design Submittal: For seismic supports, anchorages, and restraints indicated to comply with performance requirements and design criteria.
 - 1. Calculations performed for use in selection of seismic supports, anchorages, and restraints shall utilize criteria indicated in Structural Contract Documents.
 - 2. Supports, anchorage and restraints for piping, ductwork, and equipment shall be an OSHPD pre-approved system such as Tolco, Afcon, ISAT, Badger, Mason, or equal. Pipes, ducts and equipment shall be seismically restrained in accordance with requirements of current edition of California Building Code. System shall have current OPA number and shall meet additional requirements of authority having jurisdiction. Provide supporting documentation required by the reviewing authority and the Architect and Engineer. Provide layout drawings showing piping, ductwork and restraint locations.
 - a. Bracing of Piping, Ductwork, and Equipment: Specifically state how bracing attachment to structure is accomplished. Provide shop drawings indicating seismic restraints, including details of anchorage to building. In-line equipment must be braced independently of piping and ductwork, and in conformance with applicable building codes. Provide calculations to show that pre-approval numbers have been correctly applied in accordance with general information notes of pre-approval documentation. Gas pipe bracing shall be designed in accordance with California Building Code Section 1615A.1.22 and ASCE 7-05 Section 13.6. Coefficient $I_p = 1.5$ shall be used for gas piping bracing calculations.
 - 3. In lieu of the above or for non-standard installations not covered in the above pre-approved systems, Contractor shall provide layout drawings showing piping, ductwork, and restraint locations, and detail supports, attachments and restraints, and furnish supporting calculations and legible details sealed by a California registered structural engineer, in accordance with 2010 California Building Code
 - 4. Additional Requirements: In addition to the above, conform to all state and local requirements.

1.11 SUBSTITUTIONS

- A. Refer to Division 1 for complete instructions. Requirements given below are in addition to or are intended to amplify Division 1 requirements. In the case of conflict between requirements given herein and those of Division 1, Division 1 requirements shall apply.
- B. It is the responsibility of Contractor to assume costs incurred because of additional work and or changes required to incorporate proposed substitute into the Project. Refer to Division 1 for complete instructions.
- C. Substitutions will be interpreted to be all manufacturers other than those specifically listed in the Contract Documents by brand name, model or catalog number.

- D. Only one request for substitution will be considered for each item of equipment or material.
- E. Substitution requests shall include the following:
 - 1. Reason for substitution request.
 - 2. Complete submittal information as described herein; see "Submittals."
 - 3. Coordinated scale layout drawings depicting position of substituted equipment in relation to other work, with required clearances for operation, maintenance and replacement.
 - 4. List optional features required for substituted equipment to meet functional requirements of the system as indicated in Contract Documents.
 - 5. Explanation of impact on connected utilities.
 - 6. Explanation of impact on structural supports.
- F. Installation of reviewed substitution is the Contractors' responsibility. Any mechanical, electrical, structural, or other changes required for installation of reviewed substituted equipment or material must be made by the Contractor without additional cost to the Owner. Review by the Architect of the substituted equipment or material, including dimensioned Drawings will not waive these requirements.
- G. Contractor may be required to compensate the Architect for costs related to substituted equipment or material.

1.12 OPERATION AND MAINTENANCE MANUAL

- A. Instruct Owner's authorized representatives in operation, adjustment, and maintenance of mechanical equipment and systems. Provide three copies of certificate signed by Owner's representatives confirming that instruction is completed.
- B. Furnish three complete sets of Operation and Maintenance Manual bound in hardboard binder, and one compact disc containing complete Operation and Maintenance Manual in searchable PDF format. Provide Table of Contents. Provide index tabs for each piece of equipment in binder and disc. Start compiling data upon approval of submittals.
 - 1. Sets shall incorporate the following:
 - a. Service telephone number, address and contact person for each category of equipment or system.
 - b. Complete operating instructions for each item of plumbing equipment.
 - c. Copies of guarantees/warranties for each item of equipment or systems.
 - d. Test data and system balancing reports.
 - e. Typewritten maintenance instructions for each item of equipment listing lubricants to be used, frequency of lubrication, inspections required, adjustment, etc.

- f. Manufacturers' bulletins with parts numbers, instructions, etc., for each item of equipment.
 - g. Control diagrams and literature.
 - h. A complete list or schedule of all scheduled valves giving the number of the valve, location and the rooms or area controlled by the valve. Identify each valve with a permanently attached metal tag stamped with number to match schedule. Post list in frame under plastic on wall in mechanical room or where directed by Architect.
 - i. Check test and start reports for each piece of plumbing equipment provided as part of the Work.
 - j. Commissioning and Preliminary Operation Tests required as part of the Work.
- C. Post service telephone numbers and/or addresses in an appropriate place as designated by the Architect.

1.13 SITE CONDITIONS

- A. Information on Drawings relative to existing conditions is approximate. Deviations from Drawings necessary during progress of construction to conform to actual conditions shall be approved by the Architect and shall be made without additional cost to the Owner. The Contractor shall be held responsible for damage caused to existing services. Promptly notify the Architect if services are found which are not shown on Drawings.

1.14 EXISTING MATERIALS

- A. Remove existing equipment, piping, wiring, construction, etc., which interferes with Work of this Contract. Promptly return to service upon completion of work in the area. Replace items damaged by Contractor with new material to match existing.
- B. Removed materials which will not be re-installed and which are not claimed by Owner shall become property of Contractor and shall be removed from Project site. Consult Owner before removing any material from Project site. Carefully remove materials claimed by Owner to prevent damage and deliver to Owner-designated storage location.
- C. Existing piping and wiring not reused and are concealed in building construction may be abandoned in place and all ends shall be capped or plugged. Remove unused piping and wiring exposed in Equipment Rooms or occupied spaces. Material shall be removed from Project premises. Disconnect power, water, gas, pump or any other active energy source from piping or electrical service prior to abandoning in place.
- D. Existing piping, ductwork, and equipment modified or altered as part of this Work shall comply with the most recent applicable code requirements.

1.15 WARRANTY

- A. Refer to Division 1 for warranty requirements, including effective date of warranty. Refer to specific items of equipment specified herein for warranty duration if different from that specified in Division 1.

- B. Repair or replace defective work, material, or part that appears within the warranty period, including damage caused by leaks.
- C. On failure to comply with the above warranty within a reasonable length of time after notification is given, the Architect/Owner shall have the repairs made at the Contractor's expense.

1.16 RECORD DRAWINGS

- A. Refer to Division 01, Record Documents, for requirements governing Work specified herein.
- B. Upon completion of the work and as precedent to final payment, deliver to Architect the following:
 - 1. Originals of drawings showing the Work exactly as installed.
 - 2. One complete set of reproducible drawings showing the Work exactly as installed.
 - 3. One compact disc with complete set of drawings in PDF format showing the Work exactly as installed.
- C. Provide Contractor's signature, verifying accuracy of record drawings.
- D. Obtain the signature of the Project Inspector for all record drawings.

1.17 DELIVERY AND STORAGE

- A. Protect equipment, ductwork and piping delivered to Project site from weather, humidity and temperature variations, dirt, dust and other contaminants.

1.18 COORDINATION

- A. General:
 - 1. Coordinate Work in this Section with trades covered in other Specifications Sections to provide a complete, operable and sanitary installation of the highest quality workmanship.
- B. Electrical Coordination:
 - 1. Refer to the Electrical Drawings and Specifications, Division 26, for service voltage and power feed wiring for equipment specified under this section. Contractor has full responsibility for the following items of work:
 - a. Review the Electrical Drawings and Division 26 Specifications to verify that electrical services provided are adequate and compatible with equipment requirements.
 - b. If additional electrical services are required above that indicated on Electrical Drawings and in Division 26, such as more control interlock conductors, larger feeder, or separate 120 volt control power source, include cost to furnish and install additional electrical services as part of the bid.
 - c. Prior to proceeding with installation of additional electrical work, submit detailed drawings indicating exact scope of additional electrical work.

C. Mechanical Coordination:

1. Arrange for pipe spaces, chases, slots and openings in building structure during progress of construction, to accommodate mechanical system installation.
2. Coordinate installation of supporting devices. Set sleeves in poured-in-place concrete and other structural components during progress of construction.
3. Coordinate requirements for access panels and doors for mechanical items requiring access where concealed behind finished surfaces. Access panels and doors are specified in Division 8 Section "Access Doors and Frames."

PART 2 - PRODUCTS

2.01 GENERAL

- A. Materials or equipment of the same type shall be of the same brand wherever possible. All materials shall be new and in first class condition.
- B. All sizes, capacities, and efficiency ratings shown are minimum, except that gas capacity is maximum available.
- C. Refer to Division 22 10 00 and 23 80 00 for specific system piping materials.

2.02 ELECTRIC MOTORS

- A. U.S. Motors, Century Electric, General Electric, Lincoln, Gould or equal. The minimum efficiencies shall be as defined by IEEE 112 Test Method B and NEMA MG1. Provide NEMA 3R enclosure where exposed to outdoors.

2.03 MOTOR STARTERS

- A. Square D, Allen Bradley, or equal, in NEMA Type 1 enclosure, unless otherwise specified or required. Minimum starter size shall be Size 1. Provide NEMA 3R enclosure where exposed to outdoors.
- B. Where three phase motors are provided for two-speed operation, provide two speed motor starters.
 1. All three-phase starters shall have the following:
 - a. Provide magnetic motor starters for all equipment provided under the Mechanical Work. Starters shall be non-combination type. Provide part winding or reduced voltage start motors where shown or as hereinafter specified. Minimum size starter shall be Size 1.
 - b. Cover mounted hand-off-automatic switch. Starters installed exposed in occupied spaces shall have key operated HOA switch.
 - c. Three ambient compensated thermal overload.
 - d. Fused control transformer (for 120 or 24 volt service).

- e. Pilot lights, integral with the starters. Starters located outdoors shall be in NEMA IIIIR enclosures.

2.04 VALVES AND FITTINGS FOR POTABLE WATER SYSTEMS

A. General:

- 1. Provide valves and fittings conforming to lead-free requirements of California Health and Safety Code Section 116875.
- 2. Provide valves listed to NSF-61.

B. Ball Valves:

- 1. 2 inches and smaller: 600 psi CWP, cast bronze or brass body, full port, two piece, threaded ends, and reinforced PTFE seal, conforming to MSS SP-110. Nibco T-685-80-LF, Milwaukee UPBA400, Apollo 77C-LF10, Kitz 868, or equal.
- 2. 2-1/2 inches: Apollo 77C-LF10, or equal.

C. Swing Check Valves:

- 1. Minimum 200 psi CWP, bronze or brass body, suitable for regrinding, threaded ends, conforming to MSS SP-80. Milwaukee UP509, Nibco T-413LF, Kitz 822T, or equal.

D. Calibrated Balancing Valves:

- 1. General: Calibrated orifice ball type rated for 400 psig maximum operating pressure and 250 degrees F. maximum operating pressure.
 - a. Body: Brass.
 - b. Ball: 304 Stainless Steel.
 - c. Seat: Glass and Carbon filled TFE.
 - d. End Connections: Threaded.
 - e. Pressure Gage connections: Integral capped readout valves with internal check valves and drain port, for use with portable pressure differential meter.
 - f. Handle Style: Dial, with memory stops to retain set position.
- 2. Manufacturers: Subject to compliance with requirements, available manufacturers offering products that may be incorporated into the Work include the following, or equal:
 - a. 1 inch and smaller: Bell & Gossett model CB, "LF" series.

2.05 VALVES AND FITTINGS FOR NON-POTABLE WATER, COMPRESSED AIR, AND GAS SYSTEMS

A. Ball Valves:

1. 2 inches and smaller: 600 psi CWP, 150 psi SWP, cast bronze body, full port, two piece, threaded ends, and reinforced PTFE seal, conforming to MSS SP-110. Nibco T585-70, Milwaukee BA-400, Stockham T-285, or equal.
2. 2-1/2 inches and larger: Class 150, carbon steel body, full port, two piece, stainless steel vented ball, flanged ends, and reinforced PTFE seal, conforming to MSS SP-72. Nibco F-515-CS-F-66-FS, Milwaukee F20-CS-15-F-02-GO-VB, or equal.
3. Compressed Air Services: 600 psi CWP, 150 psi SWP, bronze body, full port, three piece, threaded ends, and reinforced PTFE seal, conforming to MSS SP-110. Nibco Model T-595-Y, Milwaukee BA-300, or equal.

B. Swing Check Valves: Class 125 or 150, bronze body, suitable for regrinding, threaded ends, conforming to MSS SP-80. Stockham B-321, Milwaukee 509, Nibco T-433, or equal.

C. Calibrated Balance Valves (Symbol CBV): Provide globe style valves for precision regulation and control rated 175 psi for sizes 2-1/2 inches through 12 inches and rated 240 psi for bronze sizes 2 inches and below. Each valve shall have two metering/test ports with internal check valves and protective caps. All valves must be equipped with visual position readout and concealed memory stops for repeatable regulation and control.

1. Manufacturers: Subject to compliance with requirements, available manufacturers offering products that may be incorporated into the Work include the following, or equal:
 - a. Bell & Gossett Circuit Setter Plus
 - b. Armstrong CBV
 - c. Flow Design Inc. Accusetter
 - d. Tour & Andersson
 - e. Circuit Sensor with butterfly valve above 3 inches.
 - f. Illinois Series 5000 through 2 inches.

D. Gas Shut-off Valve Above Grade:

1. 2 inches and smaller: Provide Milwaukee BB2-100, Jomar T-100NE, or equal, ball valve, CSA listed, full port, with tee handle..
2. Above 2 inches: Provide ReSun D-126, Key Port, or equal, CSA listed, rectangular port, full pipe area, 125 psi SWP, flanged ends. Provide T-Handle socket wrench and adapter fittings as required for operation of valves. Provide one package of spare lubricant sticks, sizes as required for valve sizes. Lubricant shall be the product recommended by valve manufacturer for use with type of gas conveyed by the piping system.
3. Provide valves same size as upstream piping. Make any reduction in size of gas piping down stream of shutoff valves.

E. For Gas Service Below Grade:

1. Lubricated plug cocks: ReSun Model D-126, Key Port, or equal, lubricated plug cock, CSA listed, rectangular port, full pipe area, 125 psi SWP, flanged ends. Provide extended lubrication stem, arranged to allow for lubrication of the valve from grade. The extension must be constructed to allow for lubrication of the valve and for operation of the valve from grade. Provide T-Handle socket wrench and adapter fittings as required for operation of valves. Provide one package of spare lubricant sticks, sizes as required for valve sizes. Lubricant shall be the product recommended by valve manufacturer for use with type of gas conveyed by the piping system.
 - a. Provide flanged ends on valves installed below grade. Connect to polyethylene piping with flanges and stainless steel bolts.
 - b. Anchor each valve flange to valve box with welded angle iron, or provide vertical stiff leg, minimum 18 inches into earth.
 - c. Provide Central Double O Seal Transition Fittings, or equal, flanged style for connection between valve and piping system.
 - d. Wrap valve, flanges and exposed pipe with Pabco, or equal tape wrap, installed in accordance with requirements listed under "Pipe Protection".

2.06 JOINING MATERIALS

- A. Refer to Division 22 and 23 piping sections for special joining materials not listed below.
- B. Solder Filler Metals: ASTM B 32, Grade 5A, lead free alloys. Sil-Fos 15, or equal. Include water-flushable flux according to ASTM B813.
- C. Brazing Filler Metals: AWS A5.8, BCup-3 Series, copper-phosphorus unless otherwise indicated.
- D. Welding Filler Metals: Comply with ASME B31.1 for welding materials appropriate for wall thickness and chemical analysis of steel pipe being welded.

2.07 STRAINERS FOR POTABLE WATER SYSTEMS

- A. Strainers: Full line size, conforming to lead-free requirements of California Health and safety Code Section 116875. "Y" pattern, 125 psi SWP minimum, with 304 stainless steel screens. Install all strainers with a blow-off hose valve with hose adapter. Strainer shall have gasketed cover with straight thread.
 1. Manufacturers: Subject to compliance with requirements, available manufacturers offering products that may be incorporated into the Work include the following, or equal:
 - a. 3 inches and smaller: bronze or brass body, threaded ends, with 20 mesh screen. Watts LF777SI, Wilkins SXL.

2.08 STRAINERS FOR NON-POTABLE WATER SYSTEMS

- A. Charles M. Bailey #100A, Armstrong, Muessco, or equal, Fig. 11 "Y" pattern, 125 psi WP minimum, with monel screens with 20 square mesh for 2 inches and smaller and 3/64 inch

perforations for 2-1/2 inches and larger. Install all strainers with a blow-off hose valve with hose adapter. Strainer shall have gasketed cover with straight thread.

2.09 VALVE BOXES

- A. General:
1. Where several valves or other equipment are grouped together, provide larger boxes of rectangular "vault" type adequately sized for condition and similar in construction to those specified above.
 2. Provide valve box extensions as required to set bottom of valve box tight up to top of piping in which valve is installed.
 3. Provide a tee handle wrench for each size, Alhambra Foundry Co. #A-3008, or equal.
- B. Valve Boxes in Traffic Areas: Provide Christy No. G5 traffic valve box, Brooks, or equal, 10-3/8 inches inside diameter with extensions to suit conditions, with cast iron locking cover. Provide Owner with set of special wrenches or tools as required for operation of valves.
- C. Valve Boxes in Non-Traffic Areas: Provide Christy No. F22, Brooks, or equal, 8 inches inside diameter by 30 inches long, with cast iron locking cover. Provide Owner with set of special wrenches or tools as required for operation of valves. Cut bottom of plastic body for operation of valves.
- D. Valve Box (Rectangular Vault Type): Precast concrete or cast iron with cast iron locking type covers lettered to suit service – Brooks No. 3-TL, Christy No. B3, Fraser No. 3, Alhambra A-3004 or A-3005, Alhambra E-2202, or E-2702, or equal, with extension to suit conditions.

2.10 GAUGES

- A. Marsh "Series J", U.S. Gage, Danton 800, or equal, with bronze bushed movement and front recalibration. Dials shall be white with black numerals, 3-1/2 inch dial face. Normal reading shall be at mid-scale. Provide a needle valve on each gauge connection. Supply a gauge piped with branch isolation valves across the inlet and outlet of each pump and where shown on the Drawings.
- B. Provide Pete's Plug II, Sisco P/T, or equal, test plug with Nordel core {and gasketed cap}, on inlet and outlet of each coil, boiler, condenser, chiller and heat exchanger and where shown on Drawings.

2.11 THERMOMETERS

- A. Marsh, Taylor, Palmer, or equal, 5 inch diameter bimetal dial, adjustable from face, with adjustable positioner, located to be easily read from normal personnel approach. Normal reading shall be at mid-scale.
1. Provide extension for insulation.
 2. Provide thermometers with steel bulb chambers and brass separable sockets.

- B. Provide Pete's Plug II, Sisco P/T, or equal, test plug with Nordel core, on inlet and outlet of each coil, boiler, and heat exchanger and provide two digital electronic test thermometers for each range of fluid temperature and where shown on Drawings.

2.12 ACCESS DOORS

- A. Where floors, walls, or ceilings must be penetrated for access to mechanical equipment, provide access doors, 14 inch by 14 inch minimum size in usable opening. Where entrance of a serviceman may be required, provide 20 inch by 30 inch minimum usable opening. Locate access doors/panels for non-obstructed and easy reach.
 - 1. All access doors less than 7'-0" above floors and exposed to public access shall have keyed locks.
- B. Access doors shall match those supplied in Division 08 in all respects, except as noted herein.
- C. Provide stainless steel access doors for use in toilet rooms, shower rooms, kitchens and other damp areas. Provide steel access doors with prime coat of baked-on paint for all other areas.
- D. Do not locate access doors in highly visible public areas such as lobbies, waiting areas, and primary entrance areas. Coordinate with the Architect when access is required in these areas.
- E. Where specific information or details relating to access panels different from the above is shown or given on the Drawings or other Divisions of work, then that information shall supersede this specification.
- F. Manufacturers: Subject to compliance with requirements, available manufacturers offering products which may be incorporated into the Work include Milcor, Karp, Nystrom, or Cesco, equal to the following:
 - 1. Milcor
 - a. Style K (plaster)
 - b. Style DW (gypsum board)
 - c. Style M (Masonry)
 - d. Style "Fire Rated" where required

2.13 EXPANSION LOOPS

- A. Manufactured assembly consisting of inlet and outlet elbow fittings, two sections of flexible metal hose and braid, and 180-degree return bend or center section of flexible hose. Flexible hose shall consist of corrugated metal inner hose and braided outer sheath.
- B. Provide expansion loops listed for 4 inches of movement for use in natural or propane gas piping systems.
- C. Manufacturers: Subject to compliance with requirements, available manufacturers offering products that may be incorporated into the Work include the following, or equal:

Metraflex Inc., Metraloop series.

Unisource Manufacturing, Inc., V series.

2.14 FLEXIBLE JOINTS

- A. Where indicated on Drawings, provide Metraflex Metrasphere, Style R, Mason Industries, or equal, Spherical Expansion Joints. Provide control units at each expansion joint, arranged to limit both expansion and compression.
- B. Flexible joints at entry points to building shall be Barco Ductile iron, Advanced Thermal Systems, or equal, threaded style with stainless ball and mineral filled seal.

2.15 PIPE GUIDES

- A. Where flexible connections are indicated on Drawings, provide Metraflex style IV, B-Line, or equal, pipe guides in locations recommended by manufacturer. Maximum spacing from flexible connection to first pipe guide is 4 pipe diameters, and maximum spacing from second pipe guide is 14 pipe diameters.

2.16 EQUIPMENT IDENTIFICATION

- A. Identify each piece of equipment with a permanently attached engraved bakelite plate, 1/2 inch high white letters on black background.

2.17 PIPE IDENTIFICATION

- A. Identify each piping system and indicate the direction of flow by means of Seton, Inc., Marking Services Inc., Reef Industries, Inc., or equal, pre-tensioned, coiled semi-rigid plastic pipe labels formed to circumference of pipe, requiring no fasteners or adhesive for attachment to pipe.
- B. The legends and flow arrows shall conform to ASME A13.1.

2.18 INSULATION WORK

- A. General:
 - 1. Insulation products, including insulation, insulation facings, jackets, adhesives, sealants and coatings shall not contain polybrominated diphenyl ethers (PBDEs) in penta, octa, or deca formulations in amounts greater than 0.1 percent (by mass).
 - 2. Adhesives and sealants shall comply with testing and product requirements of South Coast Air Quality Management District, Rule 1168.
 - 3. The term "piping" used herein includes pipe, valves, strainers and fittings.
 - 4. Apply insulating cement to fittings, valves and strainers and trowel smooth to the thickness of adjacent covering. Cover with jacket to match piping. Extend covering on valves up to the bonnet. Leave strainer cleanout plugs accessible.
 - 5. Provide pre-formed PVC valve and fitting covers.
 - 6. Provide Calcium Silicate rigid insulation and sheet metal sleeve, 18 inch minimum length at each pipe hanger. Seal ends of insulation to make vapor tight with jacket.

7. Urethane insulation will not be allowed above ground or on hot water piping.
8. Test insulation, jackets and lap-seal adhesives as a composite product and confirm flame spread of not more than 25 and a smoke developed rating of not more than 50 when tested in accordance with UL723 or ASTM E84.
9. Clean thoroughly, test and have approved, all piping and equipment before installing insulation and/or covering.
10. Repair all damage to existing pipe and duct insulation whether or not caused during the work of this contract, to match existing adjacent insulation for thickness and finish, but conforming to flame spread and smoke ratings specified above.

B. Insulation of Piping:

1. Insulate domestic hot and tempered water with 1 inch thick 3-1/2# minimum density fiberglass with ASJ-SSL jacket for sizes up to and including 2 inches. For larger sizes, provide 1-1/2 inch thick 3-1/2# minimum density fiberglass insulation and ASJ-SSL jacket.
2. Insulate domestic hot water piping under slab on grade and cold water piping exposed to the weather with 3/4" thick Therma-Cel, Armaflex, or equal; seal water tight per manufacturer's directions.
3. Insulate domestic cold water piping outside of insulation envelope in outside walls, vented attic spaces, and unheated spaces, including equipment rooms and below raised floor with 1 inch thick molded fiberglass, minimum density 3-1/2# per cubic foot, with ASJ-SSL jacket.
4. Exposed insulated piping within the building shall have a Zeston 2000 25/50, Proto Lo-Smoke, or equal, PVC jacket and fitting cover installed over the insulation, applied per manufacturer's instructions. Verify suitability with manufacturer of insulation. Insulation with pre-applied polymer jacket may be substituted at Contractor's option.
5. On insulated piping exposed to the weather apply .016 aluminum jacket (.014 for 12" and larger pipes) secured with 1/2 inch aluminum bands on 12 inch centers. Cover fittings with glass cloth and two coats of Foster's Sealfas 30-36, Zeston 2000, or equal, PVC fitting covers. Insulation shall be vapor tight before applying metal jacket or PVC covers.

PART 3 - EXECUTION

3.01 PLUMBING DEMOLITION

- A. Refer to Division 1 Sections "Cutting and Patching" and "Selective Demolition" for general demolition requirements and procedures.
- B. Disconnect, dismantle and remove mechanical systems, equipment, and components indicated to be removed. Coordinate with all other trades.
 1. Piping to Be Removed: Remove portion of piping indicated to be removed and cap or plug remaining piping with same or compatible piping material.

2. Piping to Be Abandoned in Place: Drain piping and cap or plug piping to remain with same or compatible piping material. Refrigerant system must be evacuated per EPA requirements.
 3. Equipment to Be Removed: Drain down and cap remaining services and remove equipment.
 4. Equipment to Be Removed and Reinstalled: Disconnect and cap services and remove, clean, and store equipment; when appropriate, reinstall, reconnect, and make equipment operational.
 5. Equipment to Be Removed and Salvaged: Disconnect and cap services and remove equipment and deliver to Owner.
- C. If pipe, insulation, or equipment to remain is damaged in appearance or is unserviceable, remove damaged or unserviceable portions and replace with new products of equal capacity and quality.

3.02 ELECTRICAL REQUIREMENTS

- A. Provide adequate working space around electrical equipment in compliance with the California Electrical Code. Coordinate the Mechanical Work with the Electrical Work to comply.
- B. Furnish necessary control diagrams and instructions for the controls. Before permitting operation of any equipment which is furnished, installed, or modified under this Section, review all associated electrical work, including overload protection devices, and assume complete responsibility for the correctness of the electrical connections and protective devices. Motors and control equipment shall conform to the Standards of the National Electrical Manufacturers' Association. All equipment and connections exposed to the weather shall be NEMA IIIIR with factory-wired strip heaters in each starter enclosure and temperature control panel where required to inhibit condensation.
- C. All line voltage and low voltage wiring and conduit associated with the Temperature Control System are included in this Section. Wiring and conduit shall comply with Division 26.
- D. Electric Motors:
 1. All motors shall be rated for continuous operation at 115% of nameplate amperage but shall be selected to operate at less than nameplate amperage throughout the entire operating cycle. Motors found exceeding the nameplate amperage shall be promptly replaced at no cost to the Owner. Horsepower shown is minimum and shall be increased as necessary to comply with above requirements. Furnish motors with splash-proof or weatherproof housings, where required or recommended by the manufacturer. Match the nameplate voltage rating with the electrical service supplied. Check Electrical Drawings. Provide a transformer for each motor not wound specifically for system voltage.

3.03 PIPING SYSTEM REQUIREMENTS

- A. Drawing plans, schematic and diagrams indicate general location and arrangement of piping systems. Indicated locations and arrangements were used to size pipe and calculate friction loss, expansion, pump sizing, and other design considerations. Install piping as indicated unless deviations to layout are approved on coordination drawings.

3.04 PRIMING AND PAINTING

- A. Perform all priming and painting on the equipment and materials as specified herein.
- B. Priming:
 - 1. Exposed ferrous metals, including piping, which are not galvanized or factory-finished shall be primed. Black steel pipe exposed to the weather shall be painted one coat of Rust-Oleum #1069 primer for black steel piping or Rust-Oleum #5260, Kelly Moore, or equal, primer for galvanized piping.
 - 2. Metal surfaces of items to be jacketed or insulated except ductwork and piping shall be given two coats of primer unless furnished with equivalent factory finish. Items to be primed shall be properly cleaned by effective means free of rust, dirt, scale, grease and other deleterious matter and then primed with the best available grade of zinc rich primer. After erection or installation, all primed surfaces shall be properly cleaned of any foreign or deleterious matter that might impair proper bonding of subsequent paint coatings. Any abrasion or other damage to the shop or field prime coat shall be properly repaired and touched up with the same material used for the original priming.
 - 3. Where equipment is provided with nameplate data, the nameplate should be masked off prior to painting. When painting is completed, remove masking material.
- C. See Painting Section for detailed requirements.

3.05 EXCAVATING

- A. Perform all excavating required for work of this Section. Provide the services of a pipe/cable locating service prior to excavating activities to determine location of existing utilities.
- B. Unless shown otherwise, provide a minimum of 2'-6" cover above top of pipe to finished grade for all service piping, unless otherwise noted. Trim trench bottom by hand or provide a 4 inch deep minimum bed of sand to provide a uniform grade and firm support throughout entire length of pipe. For all PVC pipe and for PE gas pipe, bed the pipe in 4 inch sand bed. Pipe bedding materials should be clean crushed rock, gravel or sand of which 100 percent will pass a 1 inch sieve. For pipes that are larger than 10 inches in diameter, at least 95 percent should pass a 3/4 inch sieve, and for pipes 10 inches in diameter or smaller, 100 percent should pass a 1/2 inch sieve. All other materials should have a minimum sand equivalent of 50. Only a small proportion of the native soils will meet these requirements without extensive processing; therefore, importation of pipe bedding materials should be anticipated. Pipe bedding materials shall be compacted in lifts not exceeding 6 inches in compacted thickness. Each lift shall be compacted to not less than 90 percent relative compaction at or above the optimum moisture content, in accordance with ASTM Specification D2940, except that bedding materials graded such that less than 100 percent will pass a No. 200 sieve shall be compacted in 6 inch lifts using a single pass of a flat-plate, vibratory compactor or vibratory drum. Pipe bedding materials should extend at least to the spring line.
- C. Maintain all warning signs, barricades, flares, and red lanterns as required.
- D. For all trenches 5 feet or more in depth, submit copy of permit detailed drawings showing shoring, bracing, sloping, or other provisions to be made for worker protection from the hazard of caving ground during the excavation of such trenches. Obtain a permit from the Division of Industrial Safety prior to beginning excavations. A copy of the permit shall be available at the site at all times.

3.06 BACKFILLING

- A. Backfill shall comply with applicable provisions of DIVISION 31 of these Specifications.
- B. Except under existing or proposed paved areas, walks, roads, or similar surfaces, backfill for other types of pipe shall be made using suitable excavated material or other approved material. Place backfill in 8 inch layers, measured before compaction, and compact with impact hammer to at least 90 percent relative compaction per ASTM D2940.
 - 1. Backfill plastic pipe and insulated pipe with sand for a minimum distance of 12 inches above the top of the pipe. Compact using mechanical tamping equipment.
- C. Entire backfill for excavations under existing or proposed pavements, walks, roads, or similar surfaces, under new slabs on grade, shall be made with clean sand compacted with mechanical tamping equipment vibrator to at least 90 percent relative compaction per ASTM D2940. Remove excess earth. Increase the minimum compaction within the uppermost two feet of backfill to 95 percent.
- D. Replace or repair to its original condition all sod, concrete, asphalt paving, or other materials disturbed by the trenching operation. Repair within the guarantee period as required.

3.07 INSTALLATION OF VALVES

- A. Install valves as indicated on Drawings and in the following locations:
 - 1. Shutoff Valves: Install on inlet of each plumbing equipment item, and on inlet of each plumbing fixture, and elsewhere as indicated.
 - 2. Drain Valves: Install on each plumbing equipment item located to completely drain equipment for service or repair. Install at base of each riser, at base of each rise or drop in piping system, and elsewhere indicated or required to completely drain potable water system.
 - 3. Provide gate or globe valves on inlet and outlet of each water heater or pump.
- B. General:
 - 1. Valves shall be full line size unless indicated otherwise on Drawings.
 - 2. Install horizontal valves with valve stem above horizontal, except butterfly valves.
 - 3. Install valves with unions or flanges at each piece of equipment arranged to allow service, maintenance, and equipment removal without system shutdown.
 - 4. Locate valves for easy access and provide separate support where necessary.
 - 5. Install valves in position to allow full stem movement.
 - 6. Install exposed polished or enameled connections with special care showing no tool marks or exposed threads.
 - 7. Butterfly valves conforming to the paragraph "Butterfly Valves" may be used in lieu of gate or globe valves for locations above grade.

8. Ball valves conforming to the paragraph "Ball Valves" may be used in lieu of gate valves for locations above grade for services 2-1/2 inches and smaller.
 9. Valves 2-1/2 inches and smaller (except ball valves) in nonferrous water piping systems may be solder joint type with bronze body and trim.
 10. Rigidly fasten hose bibbs, hydrants, fixture stops, compressed air outlets, and similar items to the building construction.
- C. Swing Check Valves: Install in horizontal position with hinge pin level.
- D. Calibrated Balancing Valves: Install calibrated balancing valves per manufacturers' recommendations, including requirements for straight pipe lengths at valve inlet and outlet.
- E. Gas Shut-Off Valves:
1. Provide line size ball valve in gas line to each appliance.
 2. Provide line size ball valve in gas line, to be used as emergency shut-off for science classrooms. Install valve in locking box where indicated on the drawings.
- F. Valve Adjustment: Adjust or replace valve packing after piping systems have been tested and put into service but before final adjusting and balancing. Replace valves if persistent leaking occurs.

3.08 INSTALLATION OF PIPING SYSTEMS

- A. At time of final connection, and prior to opening valve to allow pressurization of water and gas piping from existing systems, on site or off site, perform a pressure test to indicate static pressure of existing systems. If pressure on water piping is greater than 80 psi, or gas pressure is not as indicated on Contract Documents, inform Architect immediately. Do not allow piping systems to be pressurized without written consent of the Architect.
- B. General:
1. All piping shall be concealed unless shown or otherwise directed. Allow sufficient space for ceiling panel removal.
 2. Installation of piping shall be made with appropriate fittings. Bending of piping will not be accepted.
 3. Install piping to permit application of insulation and to allow valve servicing.
 4. Where piping or conduit is left exposed within a room, the same shall be run true to plumb, horizontal, or intended planes. Where possible, uniform margins are to be maintained between parallel lines and/or adjacent wall, floor, or ceiling surfaces.
 5. Horizontal runs of pipes and/or electrical conduit suspended from ceilings shall provide for a maximum headroom clearance. The clearance shall not be less than 6'-6" without written approval from the Architect.
 6. Close ends of pipe immediately after installation. Leave closure in place until removal is necessary for completion of installation.

7. Each piping system shall be thoroughly flushed and proved clean before connection to equipment.
8. Pipe the discharge of each relief valve, air vent, backflow preventer, and similar device to floor sink or drain.
9. Install exposed polished or enameled connections with special care showing no tool marks or threads at fittings.
10. Install horizontal valves with valve stem above horizontal.
11. Use reducing fittings; bushings shall not be allowed. Use eccentric reducing fittings wherever necessary to provide free drainage of lines and passage of air.
12. Verify final equipment locations for roughing-in.
13. Service Markers: Mark the location of each plugged or capped pipe with a 4 inch round by 30 inch long concrete marker, set flush with finish grade. Provide 2-1/2 inch diameter engraved brass plate as part of monument marker.
14. Furnish and install anchors or thrust blocks on PVC water lines in the ground, at all changes in direction of piping, and at all connections or branches from mains 1-1/2 inch and larger. Form anchors or thrust blocks by pouring concrete between pipe and trench wall. Thrust blocks shall be of adequate size and so placed as to take thrusts created by maximum internal water pressure. Sizing and placement shall be per manufacturer's recommendations, 2010 CPC, and IAPMO installation standards. Anchor piping to building construction.
15. Sanitary Sewer and Storm Drain: Grade piping inside building uniformly 1/4 inch per foot if possible but not less than 1/8 inch per foot. Run piping as straight as possible. Make piping connections between building piping and outside service pipe with cast iron reducers or increasers. Slope sewers uniformly between given elevations where invert elevations are shown.
16. Where piping is installed in walls within one inch of the face of stud, provide a 16 gauge sheet metal shield plate on the face of the stud. The shield plate shall extend a minimum of 1-1/2 inches beyond the outside diameter of the pipe.

C. Expansion Loops:

1. Install expansion loops where piping crosses building expansion or seismic joints, between buildings, between buildings and canopies, and as indicated on Drawings.
2. Install expansion loops of sizes matching sizes of connected piping.
3. Install grooved-joint expansion joints to grooved-end steel piping.
4. Materials of construction and end fitting type shall be consistent with pipe material and type of gas or liquid conveyed by the piping system in which expansion loop is installed.

- D. Sleeves:
1. Install Adjus-to-Crete, Pipeline Seal and Insulator, or equal, pipe sleeves of sufficient size to allow for free motion of pipe, 24 gauge galvanized steel. The space between pipe and sleeves through floor slabs on ground, through outside walls above or below grade, through roof, and other locations as directed shall be caulked with oakum and mastic and made watertight. The space between pipe and sleeve and between sleeve and slab or wall shall be sealed watertight.
 2. At Contractor's option, Link-Seal, Metraflex Metraseal, or equal, casing seals may be used in lieu of caulking. Wrap pipes through slabs on grade with 1 inch thick fiberglass insulation to completely isolate the pipe from the concrete.
- E. Floor, Wall, and Ceiling Plates:
1. Fit all pipes with or without insulation passing through walls, floors, or ceilings, and all hanger rods penetrating finished ceilings with chrome-plated or stainless escutcheon plates.
- F. Firestopping:
1. Pack the annular space between the pipe sleeves and the pipe through all floors and walls with UL listed fire stop, and sealed at the ends. All pipe penetrations shall be UL listed, Hilti, 3M Pro-Set, or equal.
 - a. Install fire caulking behind mechanical services installed within fire rated walls, to maintain continuous rating of wall construction.
 2. Provide SpecSeal Systems UL fire rated sleeve/coupling penetrators for each pipe penetration or fixture opening passing through floors, walls, partitions or floor/ceiling assemblies. All Penetrators shall comply with UL Fire Resistance Directory (Latest Edition), and in accordance with Chapter 7,CBC requirements.
 3. Sleeve penetrators shall have a built in anchor ring for waterproofing and anchoring into concrete pours or use the special fit cored hole penetrator for cored holes.
 4. Copper and steel piping shall have SpecSeal plugs on both sides of the penetrator to reduce noise and to provide waterproofing.
 5. All above Systems to be installed in strict accordance with manufacturer's instructions.
 6. Alternate firestopping systems are acceptable if approved equal. However, any deviation from the above specification requires the Contractor to be responsible for determining the suitability of the proposed products and their intended use, and the Contractor shall assume all risks and liabilities whatsoever in connection therewith.
- G. Flashing:
1. Flashing for penetrations of metal or membrane roof for mechanical items such as flues and pipes shall be coordinated with the roofing manufacturer and roofing installer for the specific roofing type. The work of this section shall include furnishing, layout, sizing, and coordination of penetrations required for the mechanical work.

- a. Furnish and install flashing and counterflashing in strict conformance with the requirements of the roofing manufacturer. Submit shop drawing details for review prior to installation.
 - b. Furnish and install counterflashing above each flashing required. Provide Stoneman, or equal, vandalproof top and flashing combination. Provide vandalproof top for each plumbing vent through roof. Elmdor/Stoneman Model 1540, 1550, 1570, or equal.
 - c. Flues and ducts shall have 24 gauge galvanized sheet metal storm collar securely clamped to the flue above the flashing.
2. For all other types of roofing system, furnish and install around each pipe, where it passes through roof, a flashing and counterflashing. All flashing shall be made of four pound seamless sheet lead with 6 inch minimum skirt and steel reinforced boot. Counterflashing shall be cast iron. For vents, provide vandalproof top and flashing combination. Elmdor/Stoneman Model 1100-4, 1100-5, 1100-7, or equal.

H. Hangers and Supports:

- 1. General: Support all equipment and piping so that it is firmly held in place by approved iron hangers and supports and special hangers as required. All components shall support weight of equipment and pipe, fluid, and pipe insulation based on spacing between supports with minimum factor of safety of five based on ultimate strength of material used. Do not exceed manufacturer's load rating. Pipe attachments or hangers, of same size as pipe or tubing on which used, or nearest available. Rigidly fasten hose faucets, fixture stops, compressed air outlets, and similar items to the building construction. The Architect shall approve all hanger material before installation. Do not support piping with plumbers' tape, wire rope, wood, or other makeshift devices. Where building structural members do not match piping support spacing, provide all "bridging" support members as required firmly attached to building structural members in a fashion approved by the Structural Engineer.
 - a. Materials, design, and type numbers per Manufacturers' Standardization Society (MSS), Standard Practice (SP)-58.
- 2. All hanger components shall be provided by one manufacturer B-Line, Grinnell, Uni-Strut, Badger, or equal.
- 3. Hanger and Support Spacing:
 - a. Vertical piping support spacing: B-line #B3373 clamps attached to the pipe above each floor to rest on the floor. Provide with lead or Teflon liners on copper tubing. Provide additional support at base of cast iron risers and support at unsupported riser joints and horizontal offsets per 2007 Mason Industries Seismic Restraint Guidelines. Provide intermediate support for vertical piping, spaced at or within the following maximum limits.

Pipe Diameter	Steel Fluid	Steel Vapor	Copper Fluid	Copper Vapor	CPVC & PVC (Note 2)
1/2 - 1"	12	6	10	6	Base and Each Floor

						(Note 1)
1-1/4 - 2"	12	Each Floor	10	6		Base and Each Floor (Note 1)
2-1/2 - 3"	12	Each Floor	10	10		Base and Each Floor (Note 1)
Over 4"	12	Each Floor	10	10		Base and Each Floor (Note 1)

Note 1: Provide mid-story guides.

Note 2: For PVC piping, provide for expansion every 30 feet per IAPMO installation standard.

- b. Vertical cast iron piping support spacing: Base and each floor not to exceed 15 feet.
- c. Horizontal piping, hanger and support spacing: Locate hangers and supports at each change of direction, within one foot of elbow, and spaced at or within following maximum limits.

Pipe Diameter	Steel Fluid	Steel Vapor	Copper Fluid	Copper Vapor	CPVC & PVC
1/2 - 1"	6	6	5	6	3
1-1/4 - 2"	7	10	6	6	4
2-1/2 - 3"	10	10	10	10	4
Over 4"	10	10	10	10	4

- d. Horizontal cast iron piping support spacing:
 - 1) Support piping at every other joint for piping length of less than 4 feet.
 - 2) For piping longer than 4 feet, provide support on each side of the coupling, within 18 inches of each joint.
 - 3) Hanger shall not be installed on the coupling.
 - 4) Provide support at each horizontal branch connection.
 - 5) Provide sway brace at 40 foot maximum spacing for all suspended pipe with no-hub joints, except where a lesser spacing is indicated in the 2007 Mason Industries Seismic Restraint Guidelines. Provide a brace on each side of a change in direction of 90 degrees or more. Brace riser joints at each floor and at 15 foot maximum intervals.

4. Individually Suspended Piping:

- a. Individually suspended piping: B-Line B3690 J-Hanger or B3100 Clevis, complete with threaded rod, or equal. All hangers on supply and return piping handling heating hot water or steam shall have a swing connector at point of support.

<u>Pipe Size</u>	<u>Rod Size</u>
2" and Smaller	3/8"
2-1/2" to 3-1/2"	1/2"
4" to 5"	5/8"
6"	3/4"

- b. Trapeze Suspension: B-Line 1-5/8 inch width channel in accordance with manufacturer's published load ratings. No deflection to exceed 1/180 of a span.
- c. Trapeze Supporting Rods: Shall have a safety factor of five; securely anchor to building structure.
- d. Pipe Clamps and Straps: B-Line B2000, B2400; isolate copper pipe with two thicknesses of 2 inches wide 10-mil polyvinyl tape. Where used for seismic support systems, provide B-Line B2400 series pipe straps.
- e. Concrete Inserts: B-line B22-I continuous insert or B2500 spot insert. Do not use actuated fasteners for support of overhead piping unless approved by Architect.

5. Support to Structure:

- a. Wood Structure: Provide and install wood blocking as required to suit structure. Provide lag screws or through bolts with length to suit requirements, and with size (diameter) to match the size of hanger rods required.
- 1) Do not install Lag screws in tension without written review and acceptance by Structural Engineer.
- | | | |
|----------------------|--------------|-------------|
| Side Beam Angle Clip | B-Line B3062 | MSS Type 34 |
| Side Beam Angle Clip | B-Line B3060 | |
| Ceiling Flange | B-Line B3199 | |
- 2) Blocking for support of piping shall be not less than 2 inch thick for piping up to 2 inch size (water filled) or 3 inch size (vapor filled). Provide 3 inch blocking for piping up through 5 inch size, and 4 inch blocking for larger piping. Provide support for blocking in accordance with Structural Engineers requirements.

- 3) Where lag screws are used, length of screw shall be 1/2 inch less than the wood blocking. Pre-drill starter holes for each lag screw.
6. Rubber Neoprene Pipe Isolators:
 - a. Pipe isolators shall comprise an internal rubber or neoprene material that isolates pipe from hanger and structure. Install at all piping located in acoustical walls. Refer to Architectural Drawings for location of acoustical walls.
 - b. Isolation material shall be either a rubber or neoprene material that prevents contact between the pipe and the structure. The rubber shall have between a 45 to 55 durometer rating and a minimum thickness of 1/2 inch.
 - c. Acceptable Suppliers:
 - 1) Vertical runs: Acousto-Plumb or equal.
 - 2) Horizontal runs: B-Line, Vibraclamp; Acousto-Plumb or equal.
 7. Provide support for piping through roof, arranged to anchor piping solidly in place at the roof penetration.
 8. Provide rigid insulation and a 12 inch long, 18 gauge galvanized sheet iron shield between the covering and the hanger whenever hangers are installed on the outside of the pipe covering.
 9. Insulate copper tubing from ferrous materials and hangers with two thicknesses of 3 inch wide, 10 mil polyvinyl tape wrapped around pipe.
 10. Provide a support or hanger close to each change of direction of pipe either horizontal or vertical and as near as possible to concentrated loads.
 11. Suspend rods from concrete inserts with removable nuts where suspended from concrete decks. Power actuated inserts will not be allowed.

3.09 PIPE JOINTS AND CONNECTIONS

- A. General:
 1. Cutting: Cut pipe and tubing square, remove rough edges or burrs. Bevel plain ends of steel pipe.
 2. Remove scale, slag, dirt and debris from inside and outside of pipe before assembly.
 3. Boss or saddle type fittings or mechanically extracted tube joints will not be allowed.
- B. Threaded Pipe: Thread pipe with tapered pipe threads according to ASME B1.20.1. Cut threads full and clean using sharp dies. Ream threaded pipe ends to remove burrs and restore full ID. Join pipe fittings and valves as follows:
 1. Apply thread compound to external pipe threads: Rectorseal No. 5, Permatex No. 1, or equal.

2. Damaged Threads: Do not use pipe or pipe fittings with threads that are corroded or damaged.
- C. Flanged Joints: Select appropriate asbestos-free, nonmetallic gasket material in size, type, and thickness suitable for domestic water service. Join flanges with gasket and bolts according to ASME B31.9.
- D. Copper Pipe and Tubing (Except pneumatic control piping): All joints shall be brazed according to ASME Section IX, Welding and Brazing Qualifications, except domestic water piping 1-1/4 inches and smaller when not buried in the ground or concrete and type DWV plumbing piping may be soldered.
1. Soldered joints: Apply water-flushable flux to end of tube. Join copper tube and fittings according to ASTM B 828.
- E. Cast Iron Soil Pipe:
1. No-Hub fittings shall be made with a torque wrench.
 2. Hub joints shall be with Ty-Seal couplings.
 3. Wrought iron, steel, or copper pipe shall have a ring or part of a coupling screwed on to form a spigot end if caulked into a joint.
 4. Connect cast iron sewer piping to outside service pipe with cast iron or vitrified clay reducers or increasers as required. Caulking of smaller pipe into the larger without a reducer or increaser will not be permitted.
- F. Welded Pipe:
1. Make up with oxyacetylene or electric arc process.
 2. All welding shall conform to the American Standard Code for Power Piping ASME B-31.1. When requested by the Architect, furnish certification from an approved testing agency or National Certified Pipe Welding Bureau that the welders performing the work are qualified.
 3. All line welds shall be of the single "V" butt type. Welds for flanges shall be of the fillet type.
 4. Where the branch is two pipe sizes smaller than the main or smaller, Bonney Weldolets, Thredolets, Nibco, or equal, may be used in lieu of welding tees.
- G. Flexible Connections:
1. Furnish and install Thermo Tech., Inc. F/J/R, Metraflex, or equal, flexible couplings with limiter bolts on piping connections to all equipment mounted on anti-vibration bases, except fan coil units under 2000 cfm, on each connection to each base mounted pump and where shown. Couplings shall be suitable for pressure and type of service.
 2. Anchor piping securely on the system side of each flexible connection.

3.10 UNIONS AND FLANGES

- A. Install Watts, EpcO, Nibco, or equal, dielectric unions or flanges at points of connection between copper or brass piping or material and steel or cast iron pipe or material except in drain, waste, vent, or rainwater piping. Bushings or couplings shall not be used. Dielectric unions installed in potable water systems shall conform to the lead-free requirements of the California Health and Safety Code Section 116875.
- B. Install unions in piping NPS 2" and smaller, and flanges in piping NPS 2-1/2" and larger whether shown or not at each connection to all equipment and tanks, and at all connections to all automatic valves, such as temperature control valves. Unions installed in potable water systems shall conform to the lead-free requirements of the California Health and Safety Code Section 116875.
- C. Locate the unions for easy removal of the equipment, tank, or valve.

3.11 ACCESS DOOR

- A. Furnish and install access doors wherever required whether shown or not for easy maintenance of mechanical systems; for example, at concealed valves, strainers, traps, cleanouts, dampers, motors, controls, operating equipment, etc. Access doors shall provide for complete removal and replacement of equipment.

3.12 CONCRETE WORK

- A. Concrete work required for work of this Section shall be included under another section of the Specification, unless otherwise noted, including poured-in-place concrete work for installing precast manholes, catch basins, etc., and shall include reinforced concrete bases for pumps, tanks, compressors, fan units, boilers, unless the work is specifically indicated on the Drawings to be furnished under this Section.
- B. Thrust blocks, underground anchors, and pads for cleanouts, valve access boxes and washer boxes are included under this Section of the Specification. Concrete shall be 3000 psi test minimum. Refer to Division 3 for concrete types.

3.13 PIPE PROTECTION

- A. Wrap bare galvanized and black steel pipe buried in the ground and to 6" above grade, including piping in conduit, with one of the following, or equal:
 - 1. Polyethylene Coating: Pressure sensitive polyethylene coating, "X-Tru-Coat" as manufactured by Pipe Line Service Corporation or "Green Line" wrap as manufactured by Royston Products, or equal.
 - a. Field Joints and Fittings: Protecto Wrap #1170 tape as manufactured by Pipe Line Service Corporation, or Primer #200 tape by Royston Products, or equal. Installation shall be as per manufacturer's recommendation and instructions.
 - 2. Tape Wrap: Pressure-sensitive polyvinyl chloride tape, "Transtex #V-10 or V-20", "Scotchwrap 50", Slipknot I00, Pabco, or equal, with continuous identification. Tape shall be a minimum of 20 mils thick for fittings and irregular surfaces, two wraps, 50 percent overlap, 40 mils total thickness. Tape shall be laminated with a suitable adhesive; widths as recommended by the manufacturer for the pipe size. Wrap straight lengths of piping with an approved wrapping machine.

- B. Field Joints: Valves and Fittings: double wrap polyvinyl chloride tape as above. Provide at least two thicknesses of tape over the joint and extend a minimum of 4 inches over adjacent pipe covering. Build up with primer to match adjacent covering thickness. Width of tape of fittings shall not exceed 3 inches. Tape shall adhere tightly to all surfaces of the fittings without air pockets.
- C. Testing: Test completed wrap of piping, including all epoxy painted piping with Tinker and Rasor Co. test machine (San Gabriel, CA - 818-287-5259), Pipeline Inspection Company (Houston, TX - 713-681-5837), or equal.
- D. Cleaning: Clean all piping thoroughly before wrapping.
 - 1. Inspection: Damaged or defective wraps shall be repaired as directed. No wrapped pipe shall be covered until approved by Architect.
- E. Sleeve copper piping/tubing installed below slab with "Polywrap-C" polyethylene sleeve, as manufactured by Northtown Pipe Protection Products, or equal. Sleeve shall be a minimum of 6 mils thick, colored blue for domestic water piping and orange for other piping. Install sleeve per manufacturer's recommendations and instructions.
- F. Sleeve copper piping/tubing installed outside building below grade with "Polywrap-C" polyethylene sleeve, as manufactured by Northtown Pipe Protection Products, or equal. Sleeve shall be a minimum of 6 mils thick, colored blue for domestic water piping. Install sleeve per manufacturer's recommendations and instructions.
- G. Covering: No rocks or sharp edges shall be backfilled against the wrap. When backfilling with other than sand, protect wrap with an outer wrapping of Kraft paper; leave in place during backfill.

3.14 PIPE IDENTIFICATION

- A. Provide temporary identification of each pipe installed, at the time of installation. Temporary identification shall be removed and replaced with permanent identification as part of the work.
- B. Apply the legend and flow arrow at all valve locations; at all points where the piping enters or leaves a wall, partition, cluster of piping or similar obstruction, at each change of direction and at approximately 20'-0" intervals on pipe runs. Variations or changes in locations and spacing may be made with the approval of the Architect. There shall be at least one marking in each room. Markings shall be located for maximum visibility from expected personnel approach.
 - 1. Apply legend and flow arrow at approximately 10'-0" intervals in science classrooms and science prep rooms.
- C. Wherever two or more pipes run parallel, the markings shall be supplied in the same relative location on each.
- D. Each valve on non-potable water piping shall be labeled with a metal tag stamped "DANGER -- NON-POTABLE WATER" in 1/4 inch high letters.
- E. Apply markings after painting and cleaning of piping and insulation is completed.

3.15 SPECIAL SEISMIC REQUIREMENTS

- A. Calculations performed for use in selection of seismic supports, anchorages, and restraints shall utilize criteria indicated in Structural Contract Documents.

- B. Supports, anchorages and restraints for all piping, ductwork and equipment shall be an OSHPD pre-approved system such as ISAT, Badger, Mason, or equal. All pipes, ducts and equipment shall be seismically restrained in accordance with the requirements of the current edition of the California Building Code. System shall have a current OPA number and shall meet any additional requirements of the authority having jurisdiction. Provide all supporting documentation required by the reviewing authority and the Architect and Engineer. Provide layout drawings showing piping, ductwork and restraint locations.
- C. In lieu of the above or for non-standard installations not covered in the above pre-approved systems, Contractor shall provide layout drawings showing piping and restraint locations, and detail supports, attachments and restraints, and furnish supporting calculations and legible details with a stamp by a California registered structural engineer, in accordance with 2010 California Building Code.
- D. Bracing of piping: Specifically state how the bracing attachment to structure is accomplished. Provide shop drawings indicating all seismic restraints, including details of anchorage to the building. All in-line equipment must be braced independently of the piping and in conformance with all applicable building codes. Provide calculations to show that the pre-approval numbers have been correctly applied in accordance with general information notes of the pre-approval documentation. Gas pipe bracing shall be designed in accordance with California Building Code Section 1615A.1.22 and ASCE 7-05 Section 13.6. Coefficient $I_p = 1.5$ shall be used for gas piping bracing calculations.
- E. Additional Requirements: In addition to the above, conform to all state and local requirements.

3.16 EXPANSION ANCHORS IN HARDENED CONCRETE

- A. Refer to Structural Drawings.
- B. Qualification Tests: The specific anchor shall have a current ICC-ES report and evaluated in cracked concrete in accordance with Acceptance Criteria AC193. The design shear and withdrawal load shall not be more than 80% of the allowable load listed in the current ICC-ES report and manufacturer's recommendations for the specific anchor.
- C. Installation: The anchors must be installed in accordance with the requirements given in ICC Research Committee Recommendations for the specific anchor.
- D. Testing: Fifty percent of the anchors shall be load-tested on each job to twice the allowable capacity in tension, except that if the design load is less than 75 pounds; only one anchor in ten need be tested. If any anchor fails, all anchors must be tested. The load test shall be performed in the presence of the project inspector.
- E. The load may be applied by any method that will effectively measure the tension in the anchor, such as direct pull with a hydraulic jack, a torque wrench calibrated using the specific anchor or calibrated spring-loading devices. Anchors in which the torque is used to expand the anchor without applying tension to the bolt may not be verified with a torque wrench.

3.17 TESTS AND ADJUSTMENTS

- A. Test the installations in accordance with the following requirements and all applicable codes:
 1. Inspector of Record should witness all tests of piping systems.
 2. Notify the Architect at least seven days in advance of any test.

3. All piping shall be tested at completion of roughing-in, or at other times as directed by the Architect.
4. Furnish all necessary materials, test pumps, gases, instruments and labor required for testing.
5. Isolate from the system all equipment that may be damaged by test pressure.
6. Make connections to existing systems with flanged connection. During testing of the new work, provide a slip-in plate to restrict test pressure to new systems only. Remove plate and complete connection to existing system at completion of testing.
 - a. Inspector of record shall witness final connection to system.

B. Test Schedule: No loss in pressure or visible leaks shall show after four hours at the pressures indicated.

Testing of Sanitary Sewer, Drain, Vent, Storm Drain may be done in segments in order to limit pressure to within manufacturer's recommendations. Test to 10 feet above the highest point in the system.

<u>System Tested</u>	<u>Test Pressure PSI</u>	<u>Test With</u>
Sanitary Sewer, Drain, Vent	10 Ft. Hd.	Water
Storm Drain, Condensate Drains	10 Ft. Hd.	Water
Domestic Water	125	Water
Natural Gas (PE)	60	Air & Non-corrosive Leak Test Fluid
Natural Gas (Steel)	100	Air & Non-corrosive Leak Test Fluid
Compressed Air, Acetylene and Oxygen	200 lb.	Air & Non-corrosive Leak Test Fluid
Gases and Vacuum	100	Air & Non-corrosive Leak Test Fluid
PVC Irrigation Piping	100	Water
Fuel Oil	1-1/2 x WP & 20"	
Distilled Deionized Water	50	Water

1. Flush distilled deionized water lines with distilled deionized water after test and approval.
2. Non-corrosive leak test fluid shall be suitable for use with the piping material specified, and with the type of gas conveyed by the piping system.

- C. Perform operational tests under simulated or actual service conditions, including one test of complete plumbing installation with all fixtures and other appliances connected, and one test of complete installation of 48 hours each for heating and cooling with all equipment connected and operating.
- D. Should any material or work fail in any of these tests, it shall be immediately removed and replaced for new material, and portion of the work replaced shall again be tested by Contractor at his own expense.
- E. Lubricate each item of equipment, including motors, before operation.

3.18 TRACER WIRES

- A. Provide tracer wire for non-metallic gas and water pipe in ground outside of buildings. Use AWG #12 tracer wire with low density high molecular weight polyethylene insulation, and lay continuously on pipe so that it is not broken or stressed by backfilling operations. Secure wire to the piping with tape at 18 inch intervals. Solder all joints. Tracer wire insulation shall be colored yellow for gas piping, blue for water piping.
- B. Terminals: Precast concrete box and cast iron locking traffic cover, Brooks 3TL, or equal; cover marked with name of service; 6 inches of loose gravel below box. Plastic terminal board with brass bolts; identify line direction with plastic tags. Test for continuity between terminals, after backfilling, in presence of Inspector.
- C. Alternate: Use electronically detectable plastic tape with metallic core, Terra Tape D, manufactured by Reef Industries, Inc., Seton, Inc., Marking Services, Inc., or equal; tape 2 inches wide, continuously imprinted "CAUTION WATER (GAS, etc.) LINE BELOW". Install, with printed side up, directly over pipe, 18 inches below finish grade. Backfill material shall be as specified for the particular condition where pipe is installed, but avoid use of crushed rock or of earth with particles larger than 1/2 inch within the top 12 inches of backfill. Take precautions to insure that tape is not damaged or misplaced during backfill operations. Terminal boxes not required.

3.19 OPERATION OF SYSTEMS

- A. Do not operate any plumbing equipment for any purpose, temporary or permanent, until all of the following has been completed:
 - 1. Complete all requirements listed under "Check, Test and Start Requirements."
 - 2. Piping has been properly cleaned. Piping systems shall be flushed and treated prior to operation.
 - 3. Filters, strainers etc. are in place.
 - 4. Bearings have been lubricated, and alignment of rotating equipment has been checked.
 - 5. Equipment has been run under observation, and is operating in a satisfactory manner.
- B. Provide test and balance agency with one set of Contract Drawings, Specifications, Addenda, Change orders issued, applicable shop drawings and submittals and temperature control drawings.

3.20 CHECK, TEST AND START REQUIREMENTS

- A. An authorized representative of the equipment manufacturer shall perform check, test and start of each piece of plumbing equipment. The representative may be an employee of the equipment manufacturer, or a manufacturer-certified contractor. Submit written certification from the manufacturer stating that the representative is qualified to perform the check test and start of the equipment.
1. As part of the submittal process, provide a copy of each manufacturer's printed startup form to be used.
 2. Some items of specified equipment may require that check, test and start of equipment must be performed by the manufacturer, using manufacturer's employees. See specific equipment Articles in these Specifications for this requirement.
 3. Provide all personnel, test instruments, and equipment to properly perform the check, test and start work.
 4. When work has been completed, provide copies of reports for review, prior to final observation of work.
- B. Provide copies of the completed check, test and start report of each item of equipment, bound with the Operation and Maintenance Manual.
- C. Upon completion of the work, provide a schedule of planned maintenance for each piece of equipment. Indicate frequency of service, recommended spare parts (including filters and lubricants), and methods for adjustment and alignment of all equipment components. Provide a copy of the schedule with each operating and maintenance manual. Provide a copy of certification from the Owner's representative indicating that they have been properly instructed in maintenance requirements for the equipment installed.

3.21 OWNER TRAINING

- A. An authorized representative of the equipment manufacturer shall train Owner-designated personnel in maintenance and adjustment of equipment. The representative may be an employee of the equipment manufacturer, or a manufacturer-certified contractor. Submit written certification from the manufacturer stating that the representative is qualified to perform the Owner training for the equipment installed.
1. As part of the submittal process, provide a training agenda outlining major topics and time allowed for each topic.
 2. Some items of specified equipment require that training must be performed by the manufacturer, using manufacturer's employees. See specific equipment Articles in these Specifications for this requirement.
 3. Contractor shall provide three copies of certification by Contractor that training has been completed, signed by Owner's representative, for inclusion in Operation and Maintenance Manual. Certificates shall include:
 - a. Listing of Owner-designated personnel completing training, by name and title.
 - b. Name and title of training instructor.

- c. Date(s) of training.
 - d. List of topics covered in training sessions.
4. Refer to specific equipment Articles for minimum training period duration for each piece of equipment.

[END OF SECTION 22 00 50]

**SECTION 22 10 00
PLUMBING PIPING SYSTEMS**

PART 1 - GENERAL

1.01 SECTION INCLUDES

- A. Pipe and fittings.
- B. Water hammer arrestors.
- C. Water filters.
- D. Hose bibbs.
- E. Gas and air outlets.
- F. Gas pressure regulating valve.
- G. Cleanouts.
- H. Floor drains.

1.02 RELATED DOCUMENTS

- A. Drawings and general provisions of the Contract, including General and Supplementary Conditions and Division 01 Specification Sections, apply to this Section.
- B. Section 22 00 50 Basic Plumbing Materials and Methods.

1.03 ADDITIONAL REQUIREMENTS

- A. Furnish and install any incidental work not shown or specified which is necessary to provide a complete and workable system.
- B. Coordinate all of work in this Section with all of the trades covered in other Sections of the Specifications to provide a complete, operable and sanitary installation of the highest quality workmanship.
- C. All plumbing work required in the course of this contract shall be performed in strict accordance with all codes and regulations. Plumbing work done under this contract shall not adversely affect the operation of the existing plumbing systems. All materials shall be new and shall match existing.

1.04 DESCRIPTION OF WORK

- A. Furnish and install all plumbing work indicated on the drawings and described herein.

1.05 QUALITY ASSURANCE

- A. Manufacturer's Qualifications: Firms regularly engaged in manufacture of plumbing piping systems products, of types, materials, and sizes required, whose products have been in satisfactory use in similar service for not less than 5 years.

- B. Contractor's Qualifications: Firm with at least 5 years of successful installation experience on projects with piping systems work similar to that required for project.
- C. Requirements of Regulatory Agencies: The publications listed below form a part of this specification; comply with provisions of these publications except as otherwise shown or specified.
 - 1. Plumbing Code Compliance: Comply with applicable portions of California Plumbing Code pertaining to selection and installation of plumbing materials and products.
 - a. NSF Compliance:
 - 1) Pipe, tube, and fittings used in potable water systems intended to supply drinking water shall meet the requirements of NSF-61 2004, "Drinking Water System Components – Health Effects."
 - 2) Plastic potable water-service piping shall meet the requirements of NSF 14 2004, "Plastic Piping Components and Related Materials."
 - 2. California Health and Safety Code Compliance: For products covered under the scope of HSC 116875 for potable water service. Products for potable water service shall be third-party certified by an approved laboratory as complying with California Health and Safety Code Section 116875.
 - 3. NFPA/ANSI Compliance: Fabricate and install natural gas systems in accordance with latest edition of NFPA 54/ANSI Z223.1 "National Fuel Gas Code."
 - 4. Utility Compliance: Fabricate and install natural gas systems in accordance with local gas utility company requirements.
 - 5. CPC Compliance: Fabricate and install natural gas systems in accordance with 2010 California Plumbing Code.
 - 6. Provide certified gas welder as defined in California Plumbing Code to weld all joints in welded gas piping.

1.06 SUBMITTALS

- A. Product Data: Submit manufacturer's technical product data and installation instructions for plumbing piping systems materials and products.
- B. Provide welding certificate for all gas pipe welders.
- C. Record Drawings: At project closeout, submit Record Drawings of installed piping systems, in accordance with requirements of Division 1.
- D. Maintenance Data: Submit maintenance data and parts lists for plumbing piping systems materials and products. Include this data, product data, shop drawings, and record drawings in Operation and Maintenance Manual; in accordance with requirements of Division 1.
- E. Pipe, pipe or plumbing fittings, fixtures, solder and flux installed in a system providing water for human consumption shall comply with lead free requirements of the California Health and Safety

Code Section 116875. Provide submittal information for products third-party certified by an approved laboratory as complying with California Health and Safety Code Section 116875.

1.07 JOB CONDITIONS

- A. Cooperation with other trades: Coordinate Work of this Section with that of other Sections to ensure that Work is carried out in an orderly fashion.
- B. Coordinate with other trades all equipment locations, pipe, duct and conduit runs, electrical outlets and fixtures, air inlets and outlets, and structural and architectural features. Provide information on location of piping and seismic bracing to all other trades as required for a completely coordinated project.

PART 2 - PRODUCTS

2.01 MATERIALS AND PRODUCTS

- A. Provide piping materials and factory-fabricated piping products of sizes, types, pressure ratings, temperature ratings, and capacities as indicated. Provide materials and products complying with California Plumbing Code. Where more than one type of material or product is indicated, selection from materials or products specified is Contractor's option.

2.02 PIPE AND FITTINGS INSIDE BUILDINGS AND BELOW COVERED WALKS AND CORRIDORS

- A. Drain and Waste Pipe Above Grade: Cast iron soil pipe and fittings, asphaltic coated, conforming to ASTM A888 and Cast Iron Soil Pipe Institute Standard 301 and so marked. Pipe and fittings shall be as manufactured by AB&I, Charlotte, Tyler Pipe, or equal. Pipe and fittings shall be the products of a single manufacturer. At Contractor's option, vertical piping above floor from lavatories, sinks, and drinking fountains may be Schedule 40 galvanized steel pipe with black cast iron drainage fittings, or DWV copper pipe and fittings.
 - 1. Joints above grade: No-Hub pipe and fittings conforming to ASTM A888 and Cast Iron Soil Pipe Institute Standard 310. Stainless steel bands by Anaco, Tyler, Ideal or equal. Provide sway brace at 20'-0" maximum spacing for suspended pipe with No-Hub joints. Provide a brace on each side of a change in direction of 90 degrees or more. Brace riser joints at each floor and at 15 foot maximum intervals (also see Specification Section 22 00 50).
 - a. Joints located over critical areas including food preparation, food storage, food serving, and eating areas shall be Husky SD 4000, Husky HD 2000, Clamp-All 125, Clamp-All 80, Mission Heavyweight, or equal, meeting the requirements of FM 1680, SD Class I or ASTM C1540.
- B. Drain and Waste Pipe Below Grade: Cast iron soil pipe and fittings, asphaltic coated, conforming to ASTM A888 and Cast Iron Soil Pipe Institute Standard 301 and so marked. Pipe and fittings shall be as manufactured by AB&I, Charlotte, Tyler Pipe, or equal. Pipe and fittings shall be the products of a single manufacturer. At Contractor's option, hub and spigot cast iron soil pipe and fittings, asphaltic coated, conforming to ASTM A-74 and so marked, may be used.
 - 1. Joints below grade: Husky SD 4000, Husky HD 2000, Clamp-All 125, Clamp-All 80, Mission Heavyweight, or equal couplings and No-Hub fittings, meeting the requirements of FM 1680, SD Class I or ASTM C1540.

2. Joints below grade (hub and spigot option): neoprene gaskets conforming to ASTM C564, as manufactured by Ty-Seal, Dual-Tite, or equal.
- C. Vent Pipe:
1. 3 inch and larger: Service weight cast iron soil pipe and fittings.
 2. 2-1/2 inch and smaller: Schedule 40 galvanized steel pipe with black cast iron drainage fittings, or DWV copper pipe and fittings.
 3. Vent pipe buried in ground and to 6 inches above ground: Service weight cast iron soil pipe and fittings. Joints in cast iron vent pipe shall be the same as specified for cast iron waste pipe below ground.
- D. Acid Waste (AW) and Vent (AV) Pipe Underground to 6 Inches Aboveground: George Fisher Sloane, Inc., "Fuseal," Orion Fittings, Inc., "Rionfuse," IPEX, "Enfield," or equal, flame-retardant Schedule 40 polypropylene pipe and fittings assembled with electrofusion joints. Piping shall comply with ASTM F1412.
- E. Acid Waste (AW) and Vent (AV) Pipe Aboveground: In inaccessible spaces or within walls, George Fisher Sloane, Inc., "Fuseal," Orion Fittings, Inc., "Rionfuse," IPEX, "Enfield," or equal, flame-retardant Schedule 40 polypropylene pipe and fittings assembled with electrofusion joints. Piping shall comply with ASTM F1412.
1. In accessible areas: George Fisher Sloan, Inc. "Fuseal," Orion Fittings, Inc. "Blueline," IPEX "Labline," or equal, flame retardant Schedule 40 polypropylene drainage pipe and fittings, with mechanical joints. Piping shall comply with ASTM F1412.
- F. Water Pipe (Tempered Water, Tempered Water Return, Hot Water, Hot Water Return and Cold Water): Type L copper tubing, hard-temper, with wrought copper fittings. Provide full solder cup for all fittings. Capped or plugged outlets shall be Schedule 40 screwed brass. Water piping below slab: Type K copper tubing, hard temper, with wrought copper fittings. At Contractor's option, pipe runs below slab having no branches may be Type K annealed copper tubing without joints. See Section 22 00 50 for pipe protection requirements for below slab copper piping.
- G. Temperature and Pressure Relief Valve Piping: Type L copper tubing, hard-temper, with wrought copper fittings. Provide full solder cup for all fittings. Capped or plugged outlets shall be Schedule 40 screwed brass.
- H. Gas Pipe: Schedule 40 black steel with malleable iron screwed fittings above grade for piping 2 inch and smaller; welded piping below grade and for above grade piping larger than 2 inches, with Class 150 welding fittings.
1. Appliance fuel connectors, as defined in 1203 of the CPC, are not acceptable for connection of equipment, except where specifically indicated on the Contract Documents.
 2. Where Drawings indicate installation of mechanical equipment on spring isolation rails or spring mounted curbs, provide flexible connection, Metraflex, Metraloop, Unisource Mfg. Co. "V" connector, or equal, CSA listed for 4 inches of movement.
 - a. Provide CSA certification for gas connections.
 3. Provide gas tight Schedule 40 conduit to vent gas piping installed below covered walks and where noted on drawings (per CPC 1211).

I. Deionized Water Piping:

1. Polyvinylidene Fluoride (PVDF) Pressure Rated Pipe and Fittings: Schedule 80 PVDF pressure rated pipe and fittings. Pipe and fittings shall meet ASTM D-1785. Threaded fittings shall comply with ASTM D-2464. The pipe and fittings shall be sterilized and capped or packaged immediately after production and all seals shall be intact when the material is delivered to the jobsite.
2. Provide continuous channel support under all horizontal piping, B-line, Grinnell, or equal PVC coated channel systems, series B11 through B72 with matching pipe clamps as appropriate, or equal.

2.03 PIPING AND FITTINGS OUTSIDE BUILDINGS AND BEYOND COVERED WALKS

A. Buried Drain, Waste, and Vent Piping:

1. Install piping from street connection to the property line in accordance with local requirements.
2. 4 inches and larger: PVC, ASTM D3034 - SDR 35; use matching Ring Tite fittings.
3. 3 inches and smaller: Cast iron soil pipe and fittings, asphaltic coated, conforming to ASTM A888 and Cast Iron Soil Pipe Institute Standard 301 and so marked. Pipe and fittings shall be as manufactured by AB&I, Charlotte, Tyler pipe, or equal. Provide Husky SD 4000, Husky HD 2000, Clamp-All 125, Clamp-All 80, Mission Heavyweight, or equal couplings and No-Hub fittings, meeting the requirements of FM 1680, SD Class I or ASTM C1540. Pipe and fittings shall be the product of a single manufacturer.

B. Acid Waste (AW) and Vent (AV) Pipe: George Fisher Sloane, Inc., "Fuseal," Orion Fittings, Inc., "Rionfuse," IPEX, "Enfield," or equal, flame-retardant polypropylene pipe and fittings assembled with electrofusion joints. Piping shall comply with ASTM F1412.

C. Gas Piping Underground: Performance Pipe, "DriscoPlex" 6500 PE 2708 (yellow), Polypipe, Inc., "Polypipe", or equal, polyethylene gas distribution pipe, ASTM D2513, ASTM D3261, and ASTM D2683 fittings with fusion welded joints. Provide piping labeled for natural gas in accordance with CPC.

1. Electrically isolate underground ferrous gas piping from the rest of the gas system with listed or approved isolation fittings installed a minimum of six inches above grade.
2. Provide Central Plastics Corp., Perfection, or equal, anodeless, single seal riser for transition from below grade polyethylene to schedule 40 steel piping above grade. Minimum horizontal length shall be 30 inches. Minimum vertical length shall be 30 inches, or greater as required. Provide fusion connection to polyethylene pipe below grade, and screwed connection to steel pipe above grade.

D. Gas Piping Aboveground to 30 inches Belowground: Schedule 40 black steel with beveled ends for welding, with Class 150 welding fittings. Mitering to form elbows or tees will not be permitted; where branch tee connections of welded piping are required, Bonney "Weldolet" Allied Pipe Fittings, or equal fittings may be used if the branch is one-half of the diameter of the main or less.

E. Drainage Pipe, Perforated or Un-perforated: J-M PVC, P.W. Pipe, or equal drainage pipe and fittings or non-reinforced concrete sewer pipe ASTM C14.

2.04 WATER HAMMER ARRESTORS

- A. Provide water hammer arrestors conforming to lead-free requirements of California Health and Safety Code Section 116875, with nesting type bellows contained within a casing having sufficient displacement volume to dissipate the calculated kinetic energy generated in the piping system. Water hammer arrestors shall be sized for type and number of fixtures served. Provide all stainless steel shell construction with stainless steel bellows and threaded connection to water system.
- B. Water hammer arrestors shall be certified under P.D.I. Standard WH201 and by ASSE Standard 1010.
- C. Select units in accordance with the requirements of Plumbing and Drainage Institute Standard P.D.I. WH201. Install above ceilings or behind wall access door at each plumbing fixture, or where plumbing fixtures are installed in groups, at each group of fixtures.
- D. Manufacturers: Subject to compliance with requirements, available manufacturers offering products that may be incorporated into the Work include the following, or equal:

Josam Company, series 75000
Smith (Jay R.) Mfg. Co., Hydrotrol 5005-5050
Mifab, series WHB

2.05 WATER FILTERS

- A. Provide Cuno Incorporated, Aqua Pure model AP510, or equal, point of use water filters, conforming to lead-free requirements of California Health and Safety Code Section 116875, in locations indicated on Drawings.
 - 1. Provide model AP517 filter cartridge at each location, with 5 micron rating and 2,000 gallon rating, to remove sediment, rust, scale and chlorine taste and odor from incoming water. 2 gallon per minute capacity.
 - 2. Provide one spare cartridge for each unit provided.

2.06 HOSE BIBBS

- A. Hose Bibbs:
 - 1. Manufacturers: Drawing schedules indicate Basis of Design products. Subject to compliance with requirements, provide product indicated on Drawings, or comparable product by one of the following, or equal:

Acorn Engineering Co.

Woodford Manufacturing Co.

2.07 GAS AND AIR OUTLETS

- A. Gas Outlets: Deck mounted Chicago 982-907BC duplex, T&S Brass, or equal; deck mounted Chicago 980-907BC single, or equal, deck-mounted Chicago 984-907BC, four outlets, or equal. Provide integral check valve, and single lever handle in compliance with ADA requirements.

2.08 GAS PRESSURE REGULATING VALVES

- A. Provide single-stage, steel-jacketed, and corrosion-resistant gas pressure regulators. Provide atmospheric vent, elevation compensator, threaded ends for 2 inches and smaller, flanged ends for 2-1/2 inches and larger, for inlet and outlet gas pressures, specific gravity, and volume flow indicated on Drawings.
- B. Manufacturers: Subject to compliance with requirements, available manufacturers offering products that may be incorporated into the Work include the following, or equal:

American Meter Series 1813B or 1813C
 Equimeter (Rockwell) Series 143-80-2 or 243-12-2

2.09 CLEANOUTS

- A. General: Install cleanouts of same diameter as pipe (4 inch maximum) in all horizontal soil and waste lines where indicated and at all points of change in direction. Cleanouts shall be located not less than 18 inches from building construction so as to provide sufficient space for rodding. No horizontal run over 50 feet inside buildings or 100 feet outside buildings shall be without cleanout, whether shown on Drawings or not. Provide two-way cleanouts where indicated on drawings, and where required for satisfactory use.
 - 1. Provide cleanouts in waste drop from each sink and urinal.
 - 2. Provide one wrench for each size and type of cleanout used. Turn over to Owner at completion of the project, and obtain receipt. Place receipt in Operation and Maintenance Manuals.
- B. Cleanouts in floor and in concrete sidewalks: Ducco Cast Iron with nickel bronze top, clamping collar and ABS plastic plug: Zurn ZN-1400-KC, or equal, with square or round top to suit floor construction.
- C. Cleanouts in composition floors: Zurn ZN-1400-X-DX, or equal (nickel bronze top).
- D. Cleanouts in concealed, aboveground cast-iron soil or waste lines: Zurn Z-1440A, or equal, with ABS plastic plug.
- E. Cleanouts in walls: Zurn Z-1441 or Z-1443, or equal, with stainless steel cover. Provide long sweep elbow or combination wye at connection to riser and install with surface of cleanout within 1/2 inch of front face of finished wall.
 - 1. Where space does not permit the above installation, provide Zurn Z-1446, or equal, with stainless steel access cover, and vandal resistant screw.
 - 2. Install face of cleanout plug within 1/2 inch of front face of finished wall.
- F. Cleanouts exterior to building in landscaped areas: Zurn Z-1449-BP, or equal, cleanout ferrule with tapered bronze plug. Where located at grade, provide 18 by 18 by 6 inch concrete pad; Trowel concrete smooth and edge; set flush with finished grade.
- G. Cleanouts in acid waste systems: Zurn ZN-1404, or equal, cleanout access housing, with ductile cast iron body and nickel bronze top. Extend acid waste piping within the cleanout, and terminate with threaded cap. Secure acid waste pipe inside cleanout access housing with setscrews provided.

- H. Manufacturers: Subject to compliance with requirements, available manufacturers offering products that may be incorporated into the Work include the following, or equal:

Zurn
J.R. Smith
Josam

- 2.10 FLOOR DRAINS Manufacturers: Drawing schedules indicate Basis of Design products. Subject to compliance with requirements, provide product indicated on Drawings, or comparable product by one of the following, or equal:

Zurn
J.R. Smith
Josam

PART 3 - EXECUTION

3.01 INSPECTION

- A. Examine areas and conditions under which plumbing piping systems are to be installed. Do not proceed with Work until unsatisfactory conditions have been corrected in manner acceptable to Contractor.
- B. Make all arrangements for the utilities required. Pay all costs involved in obtaining the services including gas service and meter, water meter, pressure reducing valve, access boxes, street work. Connect to site utilities. Verify the location of all services. No extra cost will be allowed if services are not as shown.
- C. Determine sanitary sewer and storm drain location and elevation at all points of connection before installing any piping. Notify Architect immediately if indicated grades cannot be maintained.
- D. At time of final connection, and prior to opening valve to allow pressurization of water and gas piping from existing systems, on site or off site, perform a pressure test to indicate static pressure of existing systems. If pressure on water piping is greater than 80 psi, or gas pressure is not as indicated on Contract Documents, inform Architect immediately. Do not allow piping systems to be pressurized without written consent of the Architect.

3.02 INSTALLATION OF WATER PIPING

- A. Run all water piping generally level, free of traps or unnecessary bends, arranged to conform to the building requirements, and to suit clearance for other mechanical work such as ducts, flues, conduits, and other work. No piping shall be installed so as to cause unusual noise from the flow of water therein under normal conditions.
- B. Provide manufactured water hammer arrestors, sized and installed in accordance with Plumbing and Drainage Institute Standard PDI WH201.
1. Locate water hammer arrestors at every plumbing fixture, or, where fixtures are located in groups, at every group of fixtures, and as indicated on Drawings.
 2. Install water hammer arrestors above accessible ceilings, or install access doors for service.
- C. In freezing locations arrange water piping to drain as shown.

- D. Install piping on room side of building insulation.
- E. Check final location of rubber rings within couplings on PVC water piping with gauge or as recommended by manufacturer. Make connection to valves with cast iron adapters connected to water pipe with cast iron couplings. Furnish and install anchors or thrust blocks.

3.03 INSTALLATION OF SANITARY AND STORM DRAINAGE SYSTEMS

- A. Sewer Piping: Run all horizontal sanitary drain piping inside of building on a uniform grade of not less than 1/4 inch per foot unless otherwise noted or later approved. Unless otherwise noted on the plans, piping shall have invert elevations as shown and slope uniformly between given elevations.
- B. Run all drainage piping as straight as possible and provide easy bends with long turns; make all offsets at an angle of 45 degrees or less.
- C. Grade all vent piping so as to free itself quickly of any water condensation.
- D. Where possible, join groups of vent risers together with one enlarged outlet through roof. Maintain minimum of 10 foot horizontal or 3 foot vertical clearance from air intakes.
- E. Hubless Cast Iron Joints: Comply with coupling manufacturer's installation instructions.

3.04 INSTALLATION OF ACID WASTE PIPING SYSTEMS

- A. Install to comply with all manufacturers' recommendations.
- B. All buried pipe shall be bedded in and backfilled with 4 inches of sand, and installed as recommended by manufacturer.
- C. Install piping at concrete slabs or footings with 1 inch minimum polystyrene surrounding piping.
- D. Install piping beginning at low point, true to grades and alignment indicated with unbroken continuity of invert. Maintain continuous pressure test on piping installed below grade, until all work has progressed to above grade.
- E. Electrofusion joints: Make polypropylene drainage piping joints according to ASTM F 1290.
- F. Connection to Building Sewer: At point of connection of acid waste piping to building sewer, provide fitting of same material as acid waste piping.

3.05 INSTALLATION OF CLEANOUTS

- A. Cleanouts: Install in piping as indicated, as required by California Plumbing Code, at each change in direction of piping greater than 45 degrees. Install at maximum intervals of 50 feet for piping 4 inches and smaller and 100 feet for larger piping inside buildings, and at base of each conductor.
- B. Flashing Flanges: Install flashing flange and clamping device with each cleanout passing through water resistant membrane.

3.06 INSTALLATION OF FLOOR DRAINS AND FLOOR SINKS

- A. Install drains in accordance with manufacturer's written instructions and in locations indicated. Install floor drains with lip of drain slightly below finished floor to ensure drainage. Install floor sinks flush with finished floor. Coordinate with other Contractors to ensure that floor slopes to drain. Provide flashing flange and clamping device with each drain passing through water resistant membrane.
- B. Install vented P-trap below each drain. Where trap primers are indicated, install trap primer connection in the P-trap.

3.07 INSTALLATION OF NATURAL GAS PIPING

- A. Install natural gas piping in accordance with Division 22 Basic Plumbing Materials and Methods sections.
- B. Use sealants on metal gas piping threads that are chemically resistant to natural gas. Use sealants sparingly, and apply to only male threads of metal joints.
- C. Remove cutting and threading burrs before assembling piping.
- D. Do not install defective piping or fittings. Do not use pipe with threads that are chipped, stripped, or damaged.
- E. Plug each gas outlet, including valves, with threaded plug or cap immediately after installation and retain until continuing piping or equipment connections are completed.
- F. Ground gas piping electrically and continuously within project, and bond tightly to grounding connection.
- G. Install drip-legs in gas piping where indicated and where required by code or regulation.
 - 1. Install "Tee" fitting with bottom outlet plugged or capped at bottom of pipe risers.
- H. Install piping with 1/64 inch per foot (1/8 percent) downward slope in direction of flow.
- I. Install piping parallel to other piping.
- J. Paint all gas piping installed in exposed exterior locations.
- K. Provide exterior shutoff valve at each building. Provide sign affixed to wall at valve location reading: "Gas Shut-Off." Size and location of the sign shall be as required by the Authority Having Jurisdiction. Where gas piping enters a building in more than one location, exterior shutoff valves shall have a permanently attached metal tag identifying the area served by that valve, in addition to sign on wall.
- L. Provide watertight Schedule 40 PVC conduit to protect gas piping installed below covered walk, covered driveways, and where noted on Drawings. Extend sleeve at least 12 inches beyond any area where it is required to be installed, and terminate with valve box extended to grade, and marked "GAS".

3.08 GAS PRESSURE REGULATING VALVES

- A. Install as indicated; comply with utility requirements. In locations where regulators are installed in confined spaces, pipe atmospheric vent to outdoors, full size of outlet. Install gas shutoff valve upstream and downstream of each pressure-regulating valve.

3.09 GAS PIPING EQUIPMENT CONNECTIONS

- A. Connect gas piping to each gas-fired equipment item, with union, drip leg and shutoff gas cock full size of supply line shown. Reduce only at connection to equipment. Comply with equipment manufacturer's instructions.
 - 1. Appliance fuel connectors, as defined in 1203 of the CPC, are not acceptable for connection of equipment, except where specifically indicated on the Contract Documents.
 - 2. Route gas vent and gas relief to outside.
 - 3. Gas shutoff valve shall be placed as close as possible to equipment in a location where it can be serviced. Distance from equipment to valve shall not exceed 6 feet.

3.10 EQUIPMENT CONNECTIONS

- A. Piping Runouts to Fixtures: Provide hot and cold water piping runouts to fixtures of sizes indicated.
- B. Mechanical Equipment Connections: Connect hot and cold water piping system and gas piping system to mechanical equipment as indicated, and provide with shutoff valve and union for each connection.

3.11 LABORATORY EQUIPMENT AND CASEWORK

- A. Coordinate all work with Specification Section for Laboratory Equipment and Casework.
- B. Furnish and install all required P-traps. Traps shall be Enfield, Fuseal, or equal.
- C. Provide stops on all hot and cold water lines at equipment in an accessible position.
- D. Seal all floor openings watertight.
- E. Provide approved vacuum breaker or anti-siphon device on water lines to equipment wherever required.
- F. All horizontal piping lines connected to equipment shall be run at the highest possible elevation not less than 6 inches above floor. Piping rough-in shall be stubbed in walls wherever possible.
- G. Vent piping for waste lines shall be concealed and vents for island or freestanding equipment shall be looped.

3.12 SPARE PARTS

- A. Furnish to Owner, with receipt, one valve key for each key operated hydrant, bibb, or faucet installed.

3.13 DOMESTIC WATER SYSTEM STERILIZATION

- A. Clean and disinfect all hot and cold water systems connected to domestic water systems in accordance with AWWA Standard C651 and as required by the local Building and Health Department Codes, and EPA. A water treatment company that has a current Cal-EPA license to apply disinfectant chlorine in potable water shall perform the procedure.
 - 1. Disinfect existing piping systems as required to provide continuous disinfection upstream to existing valves. At the option of the contractor, valves may be provided to isolate the new piping systems from the existing systems.
- B. Preliminary Preparation: Provide a 1 inch service cock or valve connected to system at a point within 2'-0" of its junction with water supply line and inject disinfecting agent into system through this cock. When project is complete, with all fixtures connected and operable and ready for use and when, by test, system is proved to be free from leaks, it shall be thoroughly flushed by fully opening every outlet and operating every fixture until clear water flows from all of them.
- C. Disinfecting Agent: The chlorine shall be a registered product with Cal-EPA for use in California in potable water lines, such as Bacticide, Cal-EPA Registration No. 37982-20001.
- D. Disinfecting Procedure: Connect a hand-operated pump, 100 psi rating, minimum to the 1-inch service cock or valve.
 - 1. With system completely full of water and supply valve open, adjust every faucet of system so that a trickle of water flows from each.
 - 2. Inject disinfect to provide a minimum chlorine residual concentration of at least 50 parts per million (ppm) of free chlorine at each outlet.
 - 3. Close all outlets and valves, including valve connecting to water supply line and 1-inch service cock on solution injection connection. Maintain condition for 24 hours and chlorine residual of 50 ppm should be retained in system for this 24 hour period. If, after 24 hours, present/absent test indicates that chlorine residual concentration has decreased below 50 ppm then disinfection procedure must be repeated until an approved result is obtained.
 - 4. When the above procedure has been completed, flush out entire system with fresh water until a "present/absent" test at any outlet shows a residual of not more than 0.2 ppm, or a residual the same as that of the test water.
 - 5. The on-site disinfection shall be performed under the supervision of a licensed applicator.
 - 6. Warning signs shall be provided at all outlets while chlorinating the system.
- E. Chemical and bacteriological tests shall be conducted by a state-certified laboratory and approved by the local authorities having jurisdiction. Copies of the tests shall be submitted to the Architect and all governing authorities.

3.14 CARE AND CLEANING

- A. Repair or replace broken, damaged, or otherwise defective parts, materials, and work. Leave entire work in condition satisfactory to Architect. At completion, carefully clean and adjust equipment, fixtures, and trim that are installed as part of this work. Remove labels from stainless

steel sinks, except 316 stainless steel sink labels should be retained to confirm that the correct material has been provided. Leave systems and equipment in satisfactory operating condition.

3.15 OPERATION TEST

- A. Test each piece of equipment to show that it will operate in accordance with indicated requirements.

3.16 TESTING AND BALANCING

- A. See section 23 80 00 of these specifications for testing and balancing requirements.

3.17 CLEANING UP

- A. Upon completion of Work remove materials, equipment, apparatus, tools, and the like, and leave premises clean, neat, and orderly.

[END OF SECTION 22 10 00]

**SECTION 22 40 00
PLUMBING FIXTURES**

PART 1 - GENERAL

1.01 SECTION INCLUDES

- A. Water supplies and stops.
- B. Plumbing fixture hangers and supports.

1.02 RELATED DOCUMENTS

- A. Drawings and general provisions of the Contract, including General and Supplementary Conditions and Division 1 Specification Sections, apply to this Section.
- B. Section 22 00 50 Basic Plumbing Materials and Methods.

1.03 ADDITIONAL REQUIREMENTS

- A. Furnish and install any incidental work not shown or specified which is necessary to provide a complete and workable system.
- B. Coordinate all of work in this Section with all of the Trades covered in other Sections of the Specifications to provide a complete, operable and sanitary installation of the highest quality workmanship.

1.04 DESCRIPTION OF WORK

- A. Furnish and install all plumbing work indicated on the Drawings and described herein.

1.05 QUALITY ASSURANCE

- A. Manufacturers: Firms regularly engaged in manufacture of plumbing fixtures of the type, style and configuration required. All companies providing products with warranties must have been engaged in manufacturing of such products for as long as the warranty states.
- B. Plumbing Fixture Standards: Comply with applicable portions of the following codes and requirements for all work in this section:
 - California Building Code – CBC
 - California Plumbing Code – CPC
 - California Health and Safety Code
 - American National Standards Institute - ANSI
 - Federal Standards - F.S.
 - National Sanitary Foundation – NSF International
- C. ANSI Standards: Comply with ANSI/NSF 61, "Drinking Water System Components – Health Effects."
- D. PDI Compliance: Comply with standards established by Plumbing and Drainage Institute pertaining to plumbing fixture supports.

- E. Americans with Disabilities Act (ADA).
- F. California Health and Safety Code Compliance: For products covered under the scope of HSC 116875 for potable water service. Products for potable water service shall be third-party certified by an approved laboratory as complying with California Health and Safety Code Section 116875.

1.06 SUBMITTALS

- A. Product Data: Submit manufacturer's specifications for plumbing fixtures and trim, including catalog cut of each fixture type and trim item furnished.
- B. Maintenance Data: Submit maintenance data and parts lists for each fixture type and trim item, including instructions for care of finishes. Include this data in Operation and Maintenance Manual.
- C. Pipe, pipe or plumbing fittings, fixtures, solder and flux installed in a system providing water for human consumption shall comply with lead free requirements of the California Health and Safety Code Section 116875. Provide submittal information for products third-party certified by an approved laboratory as complying with California Health and Safety Code Section 116875.

PART 2 - PRODUCTS

2.01 PLUMBING FIXTURES

- A. General: Provide factory fabricated fixtures of type, style and material indicated. For each type fixture, provide fixture manufacturer's standard trim, carrier, seats, and valves as indicated by their published product information; either as designed and constructed, or as recommended by the manufacturer, and as required for a complete, installation. Where more than one type is dedicated, selection is Contractor's option; but, all fixtures of same type must be furnished by single manufacturer.
 - 1. Take special care with the roughing-in and finished plumbing where batteries of fixtures occur.
 - 2. Take location and mounting heights for roughing-in from Architectural Drawings.
 - 3. Follow schedule on Plumbing Drawings for roughing-in connections. Set roughing-in for all fixtures exactly as per measurements furnished by the manufacturers of the fixtures used.
 - 4. Roughing-in for lavatories and sinks shall be brought in through the wall under the centerline of the drain from the fixture wherever possible and as close to the fixture as possible.

2.02 MATERIALS

- A. Provide materials that have been selected for their surface flatness and smoothness. Exposed surfaces that exhibit pitting, seam marks, roller marks, foundry sand holes, stains, discoloration, or other surface imperfections on finished units are not acceptable.
- B. Where fittings, trim and accessories are exposed or semi-exposed, provide, chromium plated 17 gauge seamless brass and match faucets and fittings. Provide 17 gauge seamless copper or brass where not exposed.

- C. Handles on all faucets and stops shall be all metal chromium plated.

2.03 PLUMBING FITTINGS, TRIM AND ACCESSORIES

- A. Water Outlets: At locations where water is supplied (by manual, automatic or remote control), provide commercial quality faucets, valves, or dispensing devices, of type and size indicated, and as required to operate as indicated.
 - 1. Include manual shutoff valves and connecting stem pipes to permit outlet servicing without shut-down of water supply piping systems.
- B. P-Traps: Include IAPMO approved removable P-traps where drains are indicated for direct connection to drainage system. P-Traps shall be less trap screw cleanout, and incorporate a chrome plated cast brass body, brass connection nuts, 17 gauge seamless brass wall return and chrome plated wall escutcheon to match trap finish.
- C. Carriers: Provide cast iron supports for fixtures of graphitic gray iron, ductile iron, or malleable iron as indicated. Where the carrier for wall mounted water closets are installed more than 6 inches behind the finished wall, provide water closet support for wide pipe chase.
- D. Fixture Bolt Caps: Provide manufacturer's standard exposed fixture bolt caps finished to match fixture finish.
- E. Escutcheons: Where fixture supplies and drains penetrate walls in exposed location, provide chrome-plated cast brass escutcheons with setscrews.
- F. Aerators: Provide aerators of types approved by Health Departments having jurisdiction. Delete aerators where not allowed by CPC for health care occupancies.
- G. Comply with additional fixture requirements contained in Fixture Schedule shown on the drawings.

2.04 MANUFACTURERS

- A. In accordance with California Plumbing Code, provide indelibly marked or embossed manufacturers name or logo, arranged so as to be visible after installation.
- B. Manufacturers: Drawing schedules indicate Basis of Design products. Subject to compliance with requirements, provide product indicated on Drawings, or comparable product by one of the following:
 - 1. Vitrified China Plumbing Fixtures:
American Standard, U.S. Plumbing Products
Crane Plumbing
Eljer Plumbingware Div., Wallace-Murray Corp.
Kohler Co.
VitrA
 - 2. Plumbing Trim:
McGuire Manufacturing Co., Inc.
Delta Commercial
Chicago Faucet Co.
T&S Brass and Bronze Works, Inc.

3. Faucets:
Chicago Faucet Co.
Symmons Scott
T&S Brass and Bronze Works, Inc.
Delta Commercial
4. Stainless Steel Sinks:
Elkay Mfg. Co.
Just Mfg. Co.
Haws Corporation
5. Emergency Equipment:
Haws Corporation
Gardian
Symmons
Bradley
Encon
6. Fixture Carriers:
Josam Mfg. Co.
J. R. Smith
Tyler Pipe; Wade Div.
Zurn Industries; Hydromechanics Div.
Mifab, Inc.

2.05 FIXTURE CONNECTIONS

- A. Make connection between fixtures and flanges on soil pipe absolutely gastight and watertight with neoprene type gaskets (wall hung fixtures) or bowl wax (floor outlet fixtures). Rubber gaskets or putty will not be permitted.
- B. Provide fixtures not having integral traps with P-traps of chromium-plated 17 gauge cast brass, with 17 gauge seamless brass wall return, connected to concealed waste in wall and sanitary fittings. Provide IAPMO approval for trap, and provide less trap screw cleanout.
 1. Manufacturers: Subject to compliance with requirements, available manufacturers offering products that may be incorporated into the Work include the following, or equal:

Dearborn Brass, Commercial series with brass nuts
Delta Commercial
McGuire Manufacturing Co., Inc.
- C. Connections from stacks or horizontal wastes to wall or floor finish for wastes from lavatories, urinals, sinks, and drinking fountains and connection between floor drains and traps shall be IPS 85 percent red brass pipe.
- D. Plumbing fixture traps connected to special waste systems shall be constructed of materials to suit the waste system.
 1. Manufacturers: Subject to compliance with requirements, available manufacturers offering products that may be incorporated into the Work include the following, or equal:

Orion
Enfield

- E. Unions on waste pipes on fixture side of traps may be slip or flange joints with soft rubber or lead gaskets. Traps shall rough in full size to waste and vent connection, using deep escutcheon plate to cover wall penetration. Compression adaptor extensions or sweat adaptors are not acceptable.

2.06 WATER SUPPLIES AND STOPS

- A. Provide 85 percent IPS threaded red brass nipple, conforming to the lead-free requirements of California Health and Safety Code Section 116875, securely anchored to building construction, for each connection to stops, hose bibbs, etc. Each fixture, except hose bibbs, shall have stop valves installed on water supply lines.
- B. Provide water supplies to fixtures with compression shut-off stops with IPS inlets and lock shield-loose key handles. Provide combination fixtures with compression stop and IPS inlet on each water supply fitting. Provide lock shield-loose key handle for each stop.
- C. Provide 1/2 inch riser tubes with reducing coupling for fixtures, unless otherwise noted.
- D. Provide cast brass escutcheon.
- E. Furnish shut-off valves on hose bibbs where directly connected to mains with no intervening valves.
- F. Manufacturers: Subject to compliance with requirements, available manufacturers offering products that may be incorporated into the Work include the following, or equal:

BrassCraft Manufacturing model SR37XC stop with 3-12AC riser and 647 escutcheon.
McGuire Manufacturing Company, Inc. model LFH2167LK

2.07 PLUMBING FIXTURE HANGERS AND SUPPORTS

- A. Residential type fixture supports are not acceptable.
- B. Install wall mounted water closets with combination support and waste fittings, with feet of support securely anchored to floor.
- C. Install floor mounted water closets with J.R. Smith, Zurn, or equal government pattern cast iron closet flanges with brass bolts, nuts, washers, and porcelain caps secured with Spackle.
- D. Install the following fixtures on concealed support with feet of support securely anchored to floor. Anchor top of support to wall construction in an approved manner.

Wall hung lavatories
Wall mounted urinals
Drinking fountains
Electric water coolers

2.08 PLUMBING FIXTURES

- A. Install all plumbing fixtures at height indicated on Architectural Drawings. Where mounting height is not indicated, install at height required by Code.

- B. Special Requirements For Accessible Fixtures:
1. Operating handle or valve for accessible water closets, urinals, lavatories, and sinks shall operate with less than 5 pounds force. Metering faucets shall be adjusted to operate between 10 and 15 seconds.
 2. Insulate exposed waste piping and domestic water supplies below accessible fixtures with CBC access code compliant molded "closed-cell" vinyl covers. Covers shall be installed using vandal resistant fasteners and must be removable. Covers shall meet flame spread rating not to exceed 25 and smoke density not to exceed 450 when tested in accordance with ASTM E-84, and shall comply with the requirements of California Code of Regulations, Title 24. Plumberex – Handy Shield, Johns Manville – Zeston 2000, or equal.

PART 3 - EXECUTION

3.01 PRODUCT HANDLING AND PROTECTION

- A. Deliver packaged materials in their original, unopened wrapping with labels intact. Protect materials from water, the elements and other damage during delivery, storage and handling.

3.02 PREPARATORY PROVISIONS

- A. The Contractor is responsible for the examination and acceptance of all conditions affecting the proper construction and/or installation of the Work of this Section. Do not proceed until all unsatisfactory conditions have been corrected. Commencing work will be construed as acceptance of all conditions by the Contractor as satisfactory for the construction and/or installation of the Work.

3.03 INSPECTION AND PREPARATION

- A. Examine roughing-in work of domestic water and waste piping systems to verify actual locations of piping connections prior to installing fixtures. Also examine floors and substrates, and conditions under which fixture work is to be accomplished. Correct any incorrect locations of piping, and other unsatisfactory conditions for installation of plumbing fixtures. Do not proceed with work until unsatisfactory conditions have been corrected.
- B. Install plumbing fixtures of types indicated where shown and at indicated heights; in accordance with fixture manufacturer's written instructions, roughing-in drawings. Ensure that plumbing fixtures comply with requirements and serve intended purposes. Comply with applicable requirements of the National Standard Plumbing Code pertaining to installation of plumbing fixtures.
- C. Fasten plumbing fixtures securely to supports or building structure; and ensure that fixtures are level and plumb. Secure plumbing supplies to blocking behind or within wall construction so as to be rigid, and not subject to pull or push movement.
- D. Install CBC accessible fixtures in accordance with Chapter 4 California Plumbing Code, and Chapters 11A and 11B California Building Code.

3.04 INSTALLATION OF FAUCETS

- A. Provide 85 percent IPS red brass pipe, conforming to lead-free requirements of California Health and Safety Code Section 116875, securely anchored to building construction, for each connection

to faucets, stops, hose bibbs, etc. Each fixture, except hose bibbs, shall have a stop valve installed on water supply lines to permit repairs without shutting off water mains.

- B. Adjust metering faucets to run for 10 to 15 seconds.

3.05 CLEAN AND PROTECT

- A. Clean plumbing fixtures of dirt and debris upon completion of installation.
- B. Protect installed fixtures from damage during the remainder of the construction period.
- C. Grout voids between all fixtures and adjacent surfaces with white Dow Silicone Sealant, arranged to shed water.

3.06 FIELD QUALITY CONTROL

- A. Upon completion of installation of plumbing fixtures and after units are water pressurized, test fixtures to demonstrate capability and compliance with requirements. When possible, correct malfunctioning units at site, then retest to demonstrate compliance; otherwise, remove and replace with new units and proceed with retesting.

3.07 EXTRA STOCK

- A. General: Furnish special wrenches and other devices necessary for servicing plumbing fixtures and trim to Owner with receipt. Furnish one device for every ten units.

[END OF SECTION 22 40 00]

**SECTION 22 50 00
PLUMBING EQUIPMENT**

PART 1 - GENERAL

1.01 SECTION INCLUDES

- A. Neutralizing basin.
- B. Instantaneous electric water heaters.
- C. Deionizer.

1.02 RELATED DOCUMENTS

- A. Drawings and general provisions of the Contract, including General and Supplementary Conditions and Division 1 Specification Sections, apply to this Section.
- B. Section 22 00 50 Basic Plumbing Materials and Methods.

1.03 ADDITIONAL REQUIREMENTS

- A. Furnish and install any incidental work not shown or specified which is necessary to provide a complete and workable system.
- B. Coordinate all of work in this Section with all of the Trades covered in other Sections of the Specifications to provide a complete, operable and sanitary installation of the highest quality workmanship.

1.04 DESCRIPTION OF WORK

- A. Furnish and install all plumbing work indicated on the Drawings and described herein.

1.05 QUALITY ASSURANCE

- A. Manufacturers: Firms regularly engaged in manufacture of plumbing equipment of type and sizes required, whose products have been in satisfactory use in similar service for not less than 5 years.
- B. Trade names or catalog numbers stated herein indicates grade or quality of materials desired.
- C. Dimensions, sizes, and capacities shown are minimum and shall not be changed without permission of Architect.
- D. UL and NEMA Compliance: Provide electric motors and electrical components required as part of plumbing equipment, which have been listed and labeled by Underwriters Laboratories and comply with NEMA standards.
- E. CEC Compliance: Comply with California Electrical Code (Title 24, Part 3) as applicable to installation and electrical connections of ancillary electrical components of plumbing equipment.
- F. ASME Relief Valve Stamps: Provide water heaters with safety relief valves bearing ASME valve markings.

- G. California Energy Commission Compliance: Provide written confirmation of listing of all water heaters in the "Directory of Certified Water Heaters," latest edition.
- H. California Health and Safety Code Compliance: For products covered under the scope of HSC 116875 for potable water service. Products for potable water service shall be third-party certified by an approved laboratory as complying with California Health and Safety Code Section 116875.

1.06 SUBMITTALS

- A. Product Data: Submit manufacturer's plumbing equipment specifications, installation and start-up instructions, capacity and ratings, with selection points clearly indicated.
- B. Maintenance Data: Submit maintenance data and parts lists for each item of plumbing equipment. Include "trouble-shooting" maintenance guides. Include this data in Operation and Maintenance Manual.
- C. Pipe, pipe or plumbing fittings, fixtures, solder and flux installed in a system providing water for human consumption shall comply with lead free requirements of the California Health and Safety Code Section 116875. Provide submittal information for products third-party certified by an approved laboratory as complying with California Health and Safety Code Section 116875.

PART 2 - PRODUCTS

2.01 MATERIALS

- A. Insulation products, including insulation, insulation facings, jackets, adhesives, sealants and coatings shall not contain polybrominated diphenyl ethers (PBDEs) in penta, octa, or deca formulations in amounts greater than 0.1 percent (by mass).

2.02 NEUTRALIZING BASIN

- A. Furnish and install, where shown and as detailed on the Drawings, a neutralizing basin complete with cover and manhole, and 4 inch vent connection. Cover and manhole shall be bolted and gasketed gas tight.
- B. Furnish sufficient limestone or marble chips in chunks 1 inch to 3 inches in size to fill the tank to within 2 inches of the outlet. Place this material in the tank at the completion of the work.

2.03 INSTANTANEOUS ELECTRIC WATER HEATERS

- A. General: Cabinet mounted stainless steel electric heating style. Flow switch activated, UL listed, 150 PSI rated.
- B. Manufacturers: Subject to compliance with requirements, available manufacturers offering products that may be incorporated into the Work include the following, or equal:

Chronomite Laboratories, Inc.
Eemax, Inc.

2.04 DEIONIZER

- A. Provide Culligan, Campbellrae, or equal, Model SS-50 mixed bed deionized water system, complete with water storage tank, PVC gooseneck faucet, and interconnecting piping for the system.
 - 1. Provide quality indicator light, with connection to 120 volt power service. Wire to have light go out when the deionizer is exhausted.
 - 2. Provide deionizer resins as required for the deionized water tank.

PART 3 - EXECUTION

3.01 PRODUCT HANDLING AND PROTECTION

- A. Deliver packaged materials in their original, unopened wrapping with labels intact. Protect materials from water, the elements and other damage during delivery, storage and handling.

3.02 PREPARATORY PROVISIONS

- A. The Contractor shall be responsible for the examination and acceptance of all conditions affecting the proper construction and/or installation of the Work of this Section and shall not proceed until all unsatisfactory conditions have been corrected. Commencing work shall be construed as acceptance of all conditions by the Contractor as satisfactory for the construction and/or installation of the Work.

3.03 INSTALLATION OF ELECTRIC WATER HEATERS

- A. Install electric water heaters as indicated, in accordance with manufacturer's installation instructions and in compliance with applicable codes.
- B. Furnish wiring diagram to Electrical Installer. Refer to Division 26 for wiring of units, not work of this section.
- C. Connect to hot and cold water lines with shutoff valve, check valve, and dielectric union in the cold water line, and ASME standard pressure and temperature relief valve and dielectric union in the hot water line. Connect drain and relief piping as noted on Drawings.
- D. Start-up, test, and adjust electric water heaters in accordance with manufacturer's start-up instructions. Check and calibrate controls.
- E. After installation has been completed, seal bottom of heaters without feet to floor with silicone sealer.

3.04 TRAINING

- A. Provide a minimum of 8 hours of training and orientation of Owners staff in proper care and operation of Plumbing Equipment.

3.05 CARE AND CLEANING

- A. Repair or replace broken, damaged, or otherwise defective parts, materials, and work. Leave entire work in condition satisfactory to Architect. At completion, carefully clean and adjust

equipment, fixtures, and trim that are installed as part of this work. Leave systems and equipment in satisfactory operating condition.

3.06 OPERATION TEST

- A. Test each piece of equipment to show that it will operate in accordance with indicated requirements.

3.07 CLEANING UP

- A. Upon completion of Work remove materials, equipment, apparatus, tools, and the like, and leave premises clean, neat, and orderly.

[END OF SECTION 22 50 00]

**SECTION 23 00 50
BASIC HVAC MATERIALS AND METHODS**

PART 1 - GENERAL

1.01 SECTION INCLUDES

- A. Electric motors.
- B. Motor starters.
- C. Access Doors.
- D. Insulation.

1.02 RELATED DOCUMENTS

- A. Drawings and general provisions of the Contract, including General and Supplementary Conditions and Division 01 Specification Sections, apply to this Section.
- B. This Section is a part of each Division 23 Section.

1.03 ADDITIONAL REQUIREMENTS

- A. Furnish and install incidental work not shown or specified necessary to provide a complete and workable system.
- B. Make all temporary connections required to maintain services, including adequate heat and cooling, during the course of the Contract without additional cost to Owner. Notify Owner seven days in advance before disrupting services.

1.04 REFERENCED STANDARDS

- A. Where material or equipment is specified to conform to referenced standards, it shall be assumed that the most recent edition of the standard in effect at the time of bid shall be used.
 - 1. CSA – Canadian Standards Association International
 - 2. ANSI - American National Standards Institute
 - 3. ASTM - American Society for Testing and Materials
 - 4. CCR - California Code of Regulations
 - a. Title 8 - Division of Industrial Safety, Subchapter 7; General Industry Safety Orders, Articles 31 through 36
 - 5. NCPWB - National Certified Pipe Welding Bureau
 - 6. CEC - California Electrical Code
 - 7. NEMA - National Electrical Manufacturers' Association

8. NFPA - National Fire Protection Association
9. OSHA - Occupational Safety and Health Act
10. UL - Underwriters' Laboratories, Inc.

1.05 DRAWINGS

- A. Examine Drawings prior to bidding of work and report discrepancies in writing to Architect.
- B. Visit Project site and examine existing conditions in order to become familiar with Project scope. Verify dimensions shown on Drawings at Project site. Bring discrepancies to the attention of Architect. Failure to examine Project site shall not constitute basis for claims for additional work because of lack of knowledge or location of hidden conditions that affect Project scope.
- C. Drawings showing location of equipment and materials are diagrammatic and job conditions will not always permit installation in location shown. The HVAC Drawings show general arrangement of equipment and materials, etc., and shall be followed as closely as existing conditions, actual building construction, and work of other trades permit.
 1. Architectural and Structural Drawings shall be considered part of the Work. These Drawings furnish Contractor with information relating to design and construction of the Project. Architectural Drawings take precedence over HVAC Drawings.
 2. Because of the small scale of HVAC Drawings, not all offsets, fittings, and accessories required are shown. Investigate structural and finish conditions affecting the Work and arrange Work accordingly. Provide offsets, fittings, and accessories required to meet conditions. Inform Architect immediately when job conditions do not permit installation of equipment and materials in the locations shown. Obtain the Architects approval prior to relocation of equipment and materials.
 3. Relocate equipment and materials installed without prior approval of the Architect. Remove and relocate equipment and materials at Contractors' expense upon Architects' direction.
 4. Minor changes in locations of equipment, piping, ducts, etc., from locations shown shall be made when directed by the Architect at no additional cost to the Owner providing such change is ordered before such items of work, or work directly connected to same are installed and providing no additional material is required.
- D. Execute work mentioned in the Specifications and not shown on the Drawings, or vice versa, the same as if specifically mentioned or shown in both.

1.06 REQUIREMENTS OF REGULATORY AGENCIES

- A. The publications listed below form part of this Specification; comply with provisions of these publications except as otherwise shown or specified.
 1. California Electrical Code, 2010
 2. National Fire Protection Association
 3. CAL-OSHA

4. California Code of Regulations, Title 24
 5. Occupational Safety and Health Administration
 6. California State Fire Marshal, Title 19 CCR
 7. California Building Code, 2010
 8. California Energy Code, 2010
 9. California Fire Code, 2010
 10. California Mechanical Code, 2010
 11. California Plumbing Code, 2010
 12. California Green Building Standards Code, 2010
 13. Other applicable state laws
- B. Nothing in Drawings or Specifications shall be construed to permit work not conforming to these codes, or to requirements of authorities having jurisdiction. It is not the intent of Drawings or Specifications to repeat requirements of codes except where necessary for clarity.
- C. Comply with State of California 2010 Energy Code for systems, equipment, and construction.
- D. When Contract Documents differ from governing codes, furnish and install larger size or higher standards called for without extra charge.
- E. No material installed as part of this Work shall contain asbestos.

1.07 FEES AND PERMITS

- A. Obtain and pay for permits and service required in installation of the Work. Arrange for required inspections and secure approvals from authorities having jurisdiction. Comply with requirements of Division 1.
- B. Arrange for utility connections and pay charges incurred, including excess service charges.

1.08 UTILITY CONNECTIONS

- A. Bear the cost of construction related to utility services, from point of connection to utility services shown on Contract Documents. This includes piping, excavation, backfill, meters, boxes, check valves, backflow prevention devices, general service valves, concrete work, and the like, whether or not Work is performed by Contractor, local water/sanitation district, public utility, other governmental agencies or agencies' assigns.

1.09 FRAMING, CUTTING AND PATCHING

- A. Special framing, recesses, chases and backing for Work of this Section, unless otherwise specified, are covered under other Specification Sections.

- B. Contractor is responsible for placement of pipe sleeves, hangers, inserts, supports, and location of openings for the Work.
- C. Cutting, patching, and repairing of existing construction to permit installation of equipment, and materials is the responsibility of Contractor. Repair or replace damage to existing work with skilled mechanics for each trade.
- D. Cut existing concrete construction with a concrete saw. Do not utilize pneumatic devices.
- E. Core openings through existing construction for passage of new piping and conduits. Cut holes of minimum diameter to suit size of pipe and associated insulation installed. Coordinate with building structure, and obtain Structural Engineer's approval prior to coring through existing construction.

1.10 SUBMITTALS

- A. Provide submittal of materials proposed for use as part of this Project. Product names in Specifications and on Drawings are used as standards of quality. Furnish standard items on specified equipment at no extra cost to the Contract regardless of disposition of submittal data. Other materials or methods shall not be used unless approved in writing by Architect. Architect's review will be required even though "or equal" or synonymous terms are used. Refer to Division 1 for complete instructions.
 - 1. Partial or incomplete submittals will not be considered.
 - 2. Quantities are Contractor's responsibility and will not be reviewed.
 - 3. Provide materials of the same brand or manufacturer for each class of equipment or material.
 - 4. Identify each item by manufacturer, brand, trade name, number, size, rating, or other data necessary to properly identify and review materials and equipment. Words "as specified" are not sufficient identification.
 - 5. Identify each submittal item by reference to items' Specification Section number and paragraph, by Drawing and detail number, and by unit tag number.
 - 6. Organize submittals in same sequence as in Specification Sections.
 - 7. Show physical arrangement, construction details, finishes, materials used in fabrications, provisions for piping entrance, access requirements for installation and maintenance, physical size, mechanical characteristics, foundation and support details, and weight.
 - a. Submit Shop Drawings, performance curves, and other pertinent data, showing size and capacity of proposed materials.
 - b. Specifically indicate, by drawn detail or note, that equipment complies with each specifically stated requirement of Contract Documents.
 - c. Drawings shall be drawn to scale and dimensioned (except schematic diagrams). Drawings may be prepared by vendor but must be submitted as instruments of Contractor, thoroughly checked and signed by Contractor before submission to Architect for review.

- d. Catalog cuts and published material may be included with supplemental scaled drawings.
- B. Review of submittals will be only for general conformance with design concept and general compliance with information given in Contract Documents. Review will not include quantities, dimensions, weights or gauges, fabrication processes, construction methods, coordination with work of other trades, or construction safety precautions, which are sole responsibility of Contractor. Review of a component of an assembly does not indicate acceptance of an assembly. Deviations from Contract Documents not clearly identified by Contractor are Contractor's responsibility and will not be reviewed by Architect.
- C. Within reasonable time after award of contract and in ample time to avoid delay of construction, submit to Architect Shop Drawings or submittals on all items of equipment and materials provided. Provide submittal in at least seven copies and in complete package.
- 1. Shop Drawings and submittals shall include Specification Section, Paragraph number, and Drawing unit symbol or detail number for reference. Organize submittals into booklets for each Specification section and submit in loose-leaf binders with index. Deviations from the Contract Documents shall be prominently displayed in the front of the submittal package and referenced to the applicable Contract requirement.
- D. Provide coordinated layouts for HVAC Ductwork systems, in accordance with Specification Section 23 80 00.
- E. Furnish to the Project Inspector complete installation instructions on material and equipment before starting installation.
- F. Have fire damper and fire smoke damper installation instructions available at Project site during construction for use by Project Inspector.
- G. Product Data for California Green Building Standards Code Compliance: For adhesives and sealants, including primers, documentation of compliance including printed statement of VOC content and chemical components.
- H. Provide product data for insulation products, including insulation, insulation facings, jackets, adhesives, sealants, and coatings, indicating compliance with requirement that these products contain less than 0.1 percent (by mass) polybrominated diphenyl ethers (PBDEs) in penta, octa, or deca formulations.
- I. Delegated-Design Submittal: For seismic supports, anchorages, and restraints indicated to comply with performance requirements and design criteria.
- 1. Calculations performed for use in selection of seismic supports, anchorages, and restraints shall utilize criteria indicated in Structural Contract Documents.
 - 2. Supports, anchorage and restraints for piping, ductwork, and equipment shall be an OSHPD pre-approved system such as Tolco, Afcon, ISAT, Badger, Mason, or equal. Pipes, ducts and equipment shall be seismically restrained in accordance with requirements of current edition of California Building Code. System shall have current OPA number and shall meet additional requirements of authority having jurisdiction. Provide supporting documentation required by the reviewing authority and the Architect and Engineer. Provide layout drawings showing piping, ductwork and restraint locations.

- a. Bracing of Piping, Ductwork, and Equipment: Specifically state how bracing attachment to structure is accomplished. Provide shop drawings indicating seismic restraints, including details of anchorage to building. In-line equipment must be braced independently of piping and ductwork, and in conformance with applicable building codes. Provide calculations to show that pre-approval numbers have been correctly applied in accordance with general information notes of pre-approval documentation.
3. In lieu of the above or for non-standard installations not covered in the above pre-approved systems, Contractor shall provide layout drawings showing piping, ductwork, and restraint locations, and detail supports, attachments and restraints, and furnish supporting calculations and legible details sealed by a California registered structural engineer, in accordance with 2010 California Building Code
4. Additional Requirements: In addition to the above, conform to all state and local requirements.

1.11 SUBSTITUTIONS

- A. Refer to Division 1 for complete instructions. Requirements given below are in addition to or are intended to amplify Division 1 requirements. In case of conflict between requirements given herein and those of Division 1, Division 1 requirements shall apply.
- B. It is the responsibility of Contractor to assume costs incurred because of additional work and or changes required to incorporate proposed substitute into the Project. Refer to Division 1 for complete instructions.
- C. Substitutions will be interpreted to be manufacturers other than those specifically listed in the Contract Documents by brand name, model, or catalog number.
- D. Only one request for substitution will be considered for each item of equipment or material.
- E. Substitution requests shall include the following:
 1. Reason for substitution request.
 2. Complete submittal information as described herein; see "Submittals."
 3. Coordinated scale layout drawings depicting position of substituted equipment in relation to other work, with required clearances for operation, maintenance and replacement.
 4. List optional features required for substituted equipment to meet functional requirements of the system as indicated in Contract Documents.
 5. Explanation of impact on connected utilities.
 6. Explanation of impact on structural supports.
- F. Installation of reviewed substitution is Contractors' responsibility. Any mechanical, electrical, structural, or other changes required for installation of substituted equipment or material must be made by Contractor without additional cost to Owner. Review by Architect of substituted equipment or material, will not waive these requirements.

- G. Contractor may be required to compensate Architect for costs related to substituted equipment or material.

1.12 OPERATION AND MAINTENANCE MANUAL

- A. Instruct Owner's authorized representatives in operation, adjustment, and maintenance of mechanical equipment and systems. Provide three copies of certificate signed by Owner's representatives confirming that instruction is completed.
- B. Furnish three complete sets of Operation and Maintenance Manual bound in hardboard binder, and one compact disc containing complete Operation and Maintenance Manual in searchable PDF format. Provide Table of Contents. Provide index tabs for each piece of equipment in binder and disc. Start compiling data upon approval of submittals.
 - 1. Sets shall incorporate the following:
 - a. Service telephone number, address and contact person for each category of equipment or system.
 - b. Complete operating instructions for each item of heating, ventilating and air conditioning equipment.
 - c. Copies of guarantees/warranties for each item of equipment or systems.
 - d. Test data and system balancing reports.
 - e. Typewritten maintenance instructions for each item of equipment listing lubricants to be used, frequency of lubrication, inspections required, adjustment, etc.
 - f. Manufacturers' bulletins with parts numbers, instructions, etc., for each item of equipment.
 - g. Temperature control diagrams and literature.
 - h. A complete list or schedule of all scheduled valves giving the number of the valve, location and the rooms or area controlled by the valve. Identify each valve with a permanently attached metal tag stamped with number to match schedule. Post list in frame under plastic on wall in mechanical room or where directed by Architect.
 - i. Check test and start reports for each piece of mechanical equipment provided as part of the Work.
 - j. Commissioning and Preliminary Operation Tests required as part of the Work.
- C. Post service telephone numbers and addresses in an appropriate place designated by Architect.

1.13 SITE CONDITIONS

- A. Information on Drawings relative to existing conditions is approximate. Deviations from Drawings necessary during progress of construction to conform to actual conditions shall be approved by the Architect and shall be made without additional cost to the Owner. The Contractor shall be

held responsible for damage caused to existing services. Promptly notify the Architect if services are found which are not shown on Drawings.

1.14 EXISTING MATERIALS

- A. Remove existing equipment, piping, wiring, construction, etc., which interferes with Work of this Contract. Promptly return to service upon completion of work in the area. Replace items damaged by Contractor with new material to match existing.
- B. Removed materials which will not be re-installed and which are not claimed by Owner shall become the property of Contractor and shall be removed from the Project site. Consult Owner before removing any material from the Project site. Carefully remove materials claimed by Owner to prevent damage and deliver to Owner-designated storage location.
- C. Existing piping and wiring not reused and are concealed in building construction may be abandoned in place and all ends shall be capped or plugged. Remove unused piping and wiring exposed in Equipment Rooms or occupied spaces. Material shall be removed from the premises. Disconnect power, water, gas, pump or any other active energy source from piping or electrical service prior to abandoning in place.

1.15 WARRANTY

- A. Refer to Division 1 for warranty requirements, including effective date of warranty. Refer to specific items of equipment specified herein for warranty duration if different from that specified in Division 1.
- B. Repair or replace defective work, material, or part that appears within the warranty period, including damage caused by leaks.
- C. On failure to comply with warranty requirements within a reasonable length of time after notification is given, Architect/Owner shall have repairs made at Contractor's expense.

1.16 RECORD DRAWINGS

- A. Refer to Division 1, Record Documents, for requirements governing Work specified herein.
- B. Upon completion of the work and as precedent to final payment, deliver to Architect the following:
 - 1. Originals of drawings showing the Work exactly as installed.
 - 2. One complete set of reproducible drawings showing the Work exactly as installed.
 - 3. One compact disc with complete set of drawings in PDF format showing the Work exactly as installed.
 - 4. Provide Contractor's signature, verifying accuracy of record drawings.
- C. Obtain the signature of the Inspector of Record for all Record Drawings.

1.17 DELIVERY AND STORAGE

- A. Protect equipment and materials delivered to Project site from weather, humidity and temperature variations, dirt, dust and other contaminants.

1.18 COORDINATION

A. General:

1. Coordinate Work in this Section with trades covered in other Specifications Sections to provide a complete, operable and sanitary installation of the highest quality workmanship.

B. Electrical Coordination:

1. Refer to the Electrical Drawings and Specifications, Division 26, for service voltage and power feed wiring for equipment specified under this section. Contractor has full responsibility for the following items of work:
 - a. Review the Electrical Drawings and Division 26 Specifications to verify that electrical services provided are adequate and compatible with equipment requirements.
 - b. If additional electrical services are required above that indicated on Electrical Drawings and in Division 26, such as more control interlock conductors, larger feeder, or separate 120 volt control power source, include cost to furnish and install additional electrical services as part of the bid.
 - c. Prior to proceeding with installation of additional electrical work, submit detailed drawings indicating exact scope of additional electrical work.

C. Mechanical Coordination:

1. Arrange for pipe spaces, chases, slots and openings in building structure during progress of construction, to accommodate mechanical system installation.
2. Coordinate installation of supporting devices. Set sleeves in poured-in-place concrete and other structural components during construction.
3. Coordinate requirements for access panels and doors for mechanical items requiring access where concealed behind finished surfaces. Access panels and doors are specified in Division 8 Section "Access Doors and Frames."

PART 2 - PRODUCTS

2.01 GENERAL

- A. Materials or equipment of the same type shall be of the same brand wherever possible. All materials shall be new and in first class condition.
- B. All sizes, capacities, and efficiency ratings shown are minimum, except that gas capacity is maximum available.
- C. Refer to Division 22 10 00 and 23 80 00 for specific system piping materials.

2.02 ELECTRIC MOTORS

- A. U.S. Motors, Century Electric, General Electric, Lincoln, Gould or equal. The minimum efficiencies shall be as defined by IEEE 112 Test Method B and NEMA MG1. Provide NEMA 3R enclosure where exposed to outdoors.

2.03 MOTOR STARTERS

- A. Square D, Allen Bradley, or equal, in NEMA Type 1 enclosure, unless otherwise specified or required. Minimum starter size shall be Size 1. Provide NEMA 3R enclosure where exposed to outdoors.
- B. Where three phase motors are provided for two-speed operation, provide two speed motor starters.
 - 1. All three-phase starters shall have the following:
 - a. Provide magnetic motor starters for all equipment provided under the Mechanical Work. Starters shall be non-combination type. Provide part winding or reduced voltage start motors where shown or as hereinafter specified. Minimum size starter shall be Size 1.
 - b. Cover mounted hand-off-automatic switch. Starters installed exposed in occupied spaces shall have key operated HOA switch.
 - c. Three ambient compensated thermal overload.
 - d. Fused control transformer (for 120 or 24 volt service).
 - e. Pilot lights, integral with the starters. Starters located outdoors shall be in NEMA IIIIR enclosures.

2.04 ACCESS DOORS

- A. Where floors, walls, or ceilings must be penetrated for access to mechanical equipment, provide access doors, 14 inch by 14 inch minimum size in usable opening. Where entrance of a serviceman may be required, provide 20 inch by 30 inch minimum usable opening. Locate access doors/panels for non-obstructed and easy reach.
 - 1. All access doors less than 7'-0" above floors and exposed to public access shall have keyed locks.
- B. Access doors shall match those supplied in Division 8 in all respects, except as noted herein.
- C. Provide stainless steel access doors for use in toilet rooms, shower rooms, kitchens and other damp areas. Provide steel access doors with prime coat of baked-on paint for all other areas.
- D. Where panels are located on ducts or plenums, provide neoprene gaskets to prevent air leakage, and use frames to set door out to flush with insulation.
- E. Provide insulated doors where located in internally insulated ducts or casings.

- F. Do not locate access doors in highly visible public areas such as lobbies, waiting areas, and primary entrance areas. Coordinate with the Architect when access is required in these areas.
- G. Where specific information or details relating to access panels different from the above is shown or given on the Drawings or other Divisions of work, then that information shall supersede this specification.
- H. Manufacturers: Subject to compliance with requirements, available manufacturers offering products which may be incorporated into the Work include Milcor, Karp, Nystrom, or Cesco, equal to the following:
 - 1. Milcor
 - a. Style K (plaster)
 - b. Style DW (gypsum board)
 - c. Style M (Masonry)
 - d. Style "Fire Rated" where required

2.05 EQUIPMENT IDENTIFICATION

- A. Identify each piece of equipment with a permanently attached engraved bakelite plate, 1/2 inch high white letters on black background.

2.06 INSULATION WORK

- A. General:
 - 1. Insulation products, including insulation, insulation facings, jackets, adhesives, sealants and coatings shall not contain polybrominated diphenyl ethers (PBDEs) in penta, octa, or deca formulations in amounts greater than 0.1 percent (by mass).
 - 2. Adhesives and sealants shall comply with testing and product requirements of South Coast Air Quality Management District, Rule 1168.
 - 3. The term "piping" used herein includes pipe, air separators, valves, strainers and fittings.
 - 4. Apply insulating cement to fittings, valves and strainers and trowel smooth to the thickness of adjacent covering. Cover with jacket to match piping. Extend covering on valves up to the bonnet. Leave strainer cleanout plugs accessible.
 - 5. Provide pre-formed PVC valve and fitting covers.
 - 6. Provide Calcium Silicate rigid insulation and sheet metal sleeve, 18 inch minimum length at each pipe hanger. Seal ends of insulation to make vapor tight with jacket.
 - 7. Urethane insulation will not be allowed above ground or on hot water piping.
 - 8. Test insulation, jackets, and lap-seal adhesives as a composite product and confirm flame spread of not more than 25 and a smoke developed rating of not more than 50 when tested in accordance with UL723, ASTM E84, or NFPA 255.

9. Clean thoroughly, test and have approved, all piping and equipment before installing insulation and/or covering.
10. Repair all damage to existing pipe and duct insulation whether or not caused during the work of this contract, to match existing adjacent insulation for thickness and finish, but conforming to flame spread and smoke ratings specified above.

B. Duct Insulation:

1. All duct insulation shall meet minimum R-value of R-8 at 3 inch thickness 3/4 pound per cubic foot density for ductwork installed outside the building insulation envelope. For ductwork installed within the building insulation envelope, duct insulation shall have a minimum R-value of R-4.2 at 2 inch thickness, 3/4 pound per cubic foot density.
2. General: Insulation applied to the exterior surface of ducts located in buildings shall have a flame spread of not more than 25 and a smoke-developed rating of not more than 50 when tested as a composite installation including insulation, facing materials, tapes and adhesives as normally applied. Material exposed within ducts or plenum shall have a flame-spread rating of not more than 25 and a smoke-developed rating of not more than 50.
3. Wrap all unlined concealed supply and return ducts with fiberglass duct wrap, manufactured as a blanket of glass fibers factory laminated to a reinforced foil/kraft vapor retarding facing. Provide 2 inch stapling and taping flange. Wrap insulation entirely around duct and secure with outward clinching staples on 6 inch centers. Provide mechanical fasteners at maximum 18 inch centers for all bottoms of duct which are greater than 24 inches. Lap all insulation joints 3" minimum. Insulate ducts installed tight against other work before hanging in place. Seal all seams, both longitudinal and transverse, and all staple and mechanical fastener penetrations of facing with scrim backed foil tape or recommended sealant, to provide a vapor tight installation.
4. On all supply and return ductwork exposed to weather and not internally lined, field apply minimum 2" thick mineral-fiber board thermal insulation, glass fibers bonded with thermosetting resin. Comply with ASTM C612, type IB without facing and with all service jacket with factory applied FRK-25 foil reinforced kraft paper. Aluminum jacket, 0.024 inch thickness sheets manufactured from aluminum alloy complying with ASTM B209, stucco embossed finish and having an integrally bonded moisture barrier over entire surface in contract with insulation.
5. Provide internal duct lining in accordance with specification section 23 80 00.

PART 3 - EXECUTION

3.01 MECHANICAL DEMOLITION

- A. Refer to Division 1 Sections "Cutting and Patching" and "Selective Demolition" for general demolition requirements and procedures.
- B. Disconnect, dismantle and remove mechanical systems, equipment, and components indicated to be removed. Coordinate with all other trades.
 1. Piping to Be Removed: Remove portion of piping indicated to be removed and cap or plug remaining piping with same or compatible piping material.

2. Piping to Be Abandoned in Place: Drain piping and cap or plug piping to remain with same or compatible piping material. Refrigerant system must be evacuated per EPA requirements.
 3. Ducts to Be Removed: Remove portion of ducts indicated to be removed and cap remaining ducts with same or compatible ductwork material.
 4. Ducts to Be Abandoned in Place: Cap or plug ducts with same or compatible ductwork material.
 5. Equipment to Be Removed: Drain down and cap remaining services and remove equipment.
 6. Equipment to Be Removed and Reinstalled: Disconnect and cap services and remove, clean, and store equipment; when appropriate, reinstall, reconnect, and make equipment operational.
 7. Equipment to Be Removed and Salvaged: Disconnect and cap services and remove equipment and deliver to Owner.
- C. If pipe, insulation, or equipment to remain is damaged in appearance or is unserviceable, remove damaged or unserviceable portions and replace with new products of equal capacity and quality.

3.02 ELECTRICAL REQUIREMENTS

- A. Provide adequate working space around electrical equipment in compliance with the California Electrical Code. Coordinate the Mechanical Work with the Electrical Work to comply.
- B. Furnish necessary control diagrams and instructions for the controls. Before permitting operation of any equipment which is furnished, installed, or modified under this Section, review all associated electrical work, including overload protection devices, and assume complete responsibility for the correctness of the electrical connections and protective devices. Motors and control equipment shall conform to the Standards of the National Electrical Manufacturers' Association. All equipment and connections exposed to the weather shall be NEMA IIIIR with factory-wired strip heaters in each starter enclosure and temperature control panel where required to inhibit condensation.
- C. All line voltage and low voltage wiring and conduit associated with the Temperature Control System are included in this Section. Wiring and conduit shall comply with Division 26.
- D. Electric Motors:
 1. All motors shall be rated for continuous operation at 115% of nameplate amperage but shall be selected to operate at less than nameplate amperage throughout the entire operating cycle. Motors found exceeding the nameplate amperage shall be promptly replaced at no cost to the Owner. Horsepower shown is minimum and shall be increased as necessary to comply with above requirements. Furnish motors with splash-proof or weatherproof housings, where required or recommended by the manufacturer. Match the nameplate voltage rating with the electrical service supplied. Check Electrical Drawings. Provide a transformer for each motor not wound specifically for system voltage.

E. Motor Starters:

1. Provide magnetic motor starters for all equipment provided under the Mechanical Work. Starters shall be non-combination type. Provide part-winding or reduced voltage start motors on all motors 50 – HP and larger, or where shown or as hereinafter specified. Minimum size starter shall be Size 1. All three-phase starters shall have the following:
 - a. Cover-mounted hand-off-automatic switch. Starters installed exposed in occupied spaces shall have key operated HOA switch.
 - b. Three ambient compensated thermal overload.
 - c. Fused control transformer (for 120 or 24 volt service).
 - d. Pilot lights, integral with the starters. Starters located outdoors shall be in NEMA IIIR enclosures.
2. Starters for single-phase motors shall have thermal overloads, Westinghouse Type MSTOLSLIP, Square D, or equal, toggle-operated with pilot light, NEMA I enclosure for starters located indoors, NEMA IIIR enclosure for starters located outdoors.
3. Provide OSHA label indicating the device starts automatically.

3.03 PIPING SYSTEM REQUIREMENTS

- A. Drawing plans, schematic and diagrams indicate general location and arrangement of piping systems. Indicated locations and arrangements were used to size pipe and calculate friction loss, expansion, pump sizing, and other design considerations. Install piping as indicated unless deviations to layout are approved on coordination drawings.

3.04 PRIMING AND PAINTING

- A. Perform all priming and painting on the equipment and materials as specified herein.
- B. Priming:
 1. Exposed ferrous metals, including piping, which are not galvanized or factory-finished shall be primed. Black steel pipe exposed to the weather shall be painted one coat of Rust-Oleum #1069 primer for black steel piping or Rust-Oleum #5260, Kelly Moore, or equal, primer for galvanized piping.
 2. Metal surfaces of items to be jacketed or insulated except ductwork and piping shall be given two coats of primer unless furnished with equivalent factory finish. Items to be primed shall be properly cleaned by effective means free of rust, dirt, scale, grease and other deleterious matter and then primed with the best available grade of zinc rich primer. After erection or installation, all primed surfaces shall be properly cleaned of any foreign or deleterious matter that might impair proper bonding of subsequent paint coatings. Any abrasion or other damage to the shop or field prime coat shall be properly repaired and touched up with the same material used for the original priming.
 3. Where equipment is provided with nameplate data, the nameplate should be masked off prior to painting. When painting is completed, remove masking material.

C. See Painting Section for detailed requirements.

3.05 INSTALLATION OF PIPING AND DUCT SYSTEMS

A. General:

1. All piping shall be concealed unless shown or otherwise directed. Allow sufficient space for ceiling panel removal.
2. Installation of piping shall be made with appropriate fittings. Bending of piping will not be accepted.
3. Install piping to permit application of insulation and to allow valve servicing.
4. Where piping or conduit is left exposed within a room, the same shall be run true to plumb, horizontal, or intended planes. Where possible, uniform margins are to be maintained between parallel lines and/or adjacent wall, floor, or ceiling surfaces.
5. Horizontal runs of pipes and/or electrical conduit suspended from ceilings shall provide for a maximum headroom clearance. The clearance shall not be less than 6'-6" without written approval from the Architect.
6. Close ends of pipe immediately after installation. Leave closure in place until removal is necessary for completion of installation.
7. At the time of rough installation, or during storage on the construction site and until final startup of the heating and cooling equipment, all duct and other related air distribution component opening shall be covered with tape, plastic, sheet metal, or other methods acceptable to the enforcing agency.
8. Each piping system shall be thoroughly flushed and proved clean before connection to equipment.
9. Install exposed polished or enameled connections with special care showing no tool marks or threads at fittings.
10. Install horizontal valves with valve stem above horizontal.
11. Use reducing fittings; bushings shall not be allowed. Use eccentric reducing fittings wherever necessary to provide free drainage of lines and passage of air.
12. Verify final equipment locations for roughing-in.
13. Where piping is installed in walls within one inch of the face of stud, provide a 16 gauge sheet metal shield plate on the face of the stud. The shield plate shall extend a minimum of 1-1/2 inches beyond the outside diameter of the pipe.

B. Sleeves:

1. Install Adjus-to-Crete, Pipeline Seal and Insulator, or equal, pipe sleeves of sufficient size to allow for free motion of pipe, 24 gauge galvanized steel. The space between pipe and sleeves through floor slabs on ground, through outside walls above or below grade, through roof, and other locations as directed shall be caulked with oakum and mastic and

made watertight. The space between pipe and sleeve and between sleeve and slab or wall shall be sealed watertight.

2. At Contractor's option, Link-Seal, Metraflex Metraseal, or equal, casing seals may be used in lieu of caulking. Wrap pipes through slabs on grade with 1 inch thick fiberglass insulation to completely isolate the pipe from the concrete.

C. Floor, Wall, and Ceiling Plates:

1. Fit all pipes with or without insulation passing through walls, floors, or ceilings, and all hanger rods penetrating finished ceilings with chrome-plated or stainless escutcheon plates.

D. Firestopping:

1. Pack the annular space between the pipe sleeves and the pipe and between duct openings and ducts through all floors and walls with UL listed fire stop, and sealed at the ends. All pipe penetrations shall be UL listed, Hilti, 3M Pro-Set, or equal.
 - a. Install fire caulking behind mechanical services installed within fire rated walls, to maintain continuous rating of wall construction.
2. Provide SpecSeal Systems UL fire rated sleeve/coupling penetrators for each pipe penetration or fixture opening passing through floors, walls, partitions or floor/ceiling assemblies. All Penetrators shall comply with UL Fire Resistance Directory (Latest Edition), and in accordance with Chapter 7,CBC requirements.
3. Sleeve penetrators shall have a built in anchor ring for waterproofing and anchoring into concrete pours or use the special fit cored hole penetrator for cored holes.
4. Copper and steel piping shall have SpecSeal plugs on both sides of the penetrator to reduce noise and to provide waterproofing.
5. All above Systems to be installed in strict accordance with manufacturer's instructions.
6. Alternate firestopping systems are acceptable if approved equal. However, any deviation from the above specification requires the Contractor to be responsible for determining the suitability of the proposed products and their intended use, and the Contractor shall assume all risks and liabilities whatsoever in connection therewith.

E. Flashing:

1. Flashing for penetrations of metal or membrane roof for mechanical items such as flues, ducts, and pipes shall be coordinated with the roofing manufacturer and roofing installer for the specific roofing type. The work of this section shall include furnishing, layout, sizing, and coordination of penetrations required for the mechanical work.
 - a. Furnish and install flashing and counterflashing in strict conformance with the requirements of the roofing manufacturer. Submit shop drawing details for review prior to installation.
 - b. Furnish and install counterflashing above each flashing required. Provide Stoneman, or equal, vandalproof top and flashing combination. Elmdor/Stoneman Model 1540.

- c. Flues and ducts shall have 24 gauge galvanized sheet metal storm collar securely clamped to the flue above the flashing.
- 2. For all other types of roofing system, furnish and install around each pipe, where it passes through roof, a flashing and counterflashing. All flashing shall be made of four pound seamless sheet lead with 6 inch minimum skirt and steel reinforced boot. Counterflashing shall be cast iron. For vents, provide vandalproof top and flashing combination. Elmdor/Stoneman Model 1100-4.

F. Hangers and Supports:

- 1. General: Support all ductwork, equipment and piping so that it is firmly held in place by approved iron hangers and supports and special hangers as required. All components shall support weight of ductwork, equipment and pipe, fluid, and pipe insulation based on spacing between supports with minimum factor of safety of five based on ultimate strength of material used. Do not exceed manufacturer's load rating. Pipe attachments or hangers, of same size as pipe or tubing on which used, or nearest available. Rigidly fasten hose faucets, fixture stops, compressed air outlets, and similar items to the building construction. The Architect shall approve all hanger material before installation. Do not support piping or ductwork with plumbers' tape, wire rope, wood, or other makeshift devices. Where building structural members do not match piping and ductwork support spacing, provide all "bridging" support members as required firmly attached to building structural members in a fashion approved by the Structural Engineer.
 - a. Materials, design, and type numbers per Manufacturers' Standardization Society (MSS), Standard Practice (SP)-58.
- 2. All hanger components shall be provided by one manufacturer: B-Line, Grinnell, Uni-Strut, Badger, or equal.
- 3. Hanger and Support Spacing:
 - a. Vertical piping support spacing: B-line #B3373 clamps attached to the pipe above each floor to rest on the floor. Provide with lead or Teflon liners on copper tubing. Provide additional support at base of cast iron risers and support at unsupported riser joints and horizontal offsets per 2007 Mason Industries Seismic Restraint Guidelines. Provide intermediate support for vertical piping, spaced at or within the following maximum limits.

Pipe Diameter	Steel Fluid	Steel Vapor	Copper Fluid	Copper Vapor	CPVC & PVC (Note 2)
1/2 - 1"	12	6	10	6	Base and Each Floor (Note 1)
1-1/4 - 2"	12	Each Floor	10	6	Base and Each Floor (Note 1)
2-1/2 - 3"	12	Each Floor	10	10	Base and Each Floor (Note 1)

Over 4"	12	Each Floor	10	10	Base and Each Floor (Note 1)
---------	----	------------	----	----	------------------------------

Note 1: Provide mid-story guides.

Note 2: For PVC piping, provide for expansion every 30 feet per IAPMO installation standard.

- b. Vertical cast iron piping support spacing: Base and each floor not to exceed 15 feet.
- c. Horizontal piping, hanger and support spacing: Locate hangers and supports at each change of direction, within one foot of elbow, and spaced at or within following maximum limits.

Pipe Diameter	Steel Fluid	Steel Vapor	Copper Fluid	Copper Vapor	CPVC & PVC
1/2 - 1"	6	6	5	6	3
1-1/4 - 2"	7	10	6	6	4
2-1/2 - 3"	10	10	10	10	4
Over 4"	10	10	10	10	4

- d. Horizontal cast iron piping support spacing:
 - 1) Support piping at every other joint for piping length of less than 4 feet.
 - 2) For piping longer than 4 feet, provide support on each side of the coupling, within 18 inches of each joint.
 - 3) Hanger shall not be installed on the coupling.
 - 4) Provide support at each horizontal branch connection.
 - 5) Provide sway brace at 40 foot maximum spacing for all suspended pipe with no-hub joints, except where a lesser spacing is indicated in the 2007 Mason Industries Seismic Restraint Guidelines. Provide a brace on each side of a change in direction of 90 degrees or more. Brace riser joints at each floor and at 15 foot maximum intervals.

4. Individually Suspended Piping:

- a. Individually suspended piping: B-Line B3690 J-Hanger or B3100 Clevis, complete with threaded rod, or equal. All hangers on supply and return piping handling heating hot water or steam shall have a swing connector at point of support.

<u>Pipe Size</u>	<u>Rod Size</u>
2" and Smaller	3/8"
2-1/2" to 3-1/2"	1/2"
4" to 5"	5/8"
6"	3/4"

- b. Trapeze Suspension: B-Line 1-5/8 inch width channel in accordance with manufacturer's published load ratings. No deflection to exceed 1/180 of a span.
- c. Trapeze Supporting Rods: Shall have a safety factor of five; securely anchor to building structure.
- d. Pipe Clamps and Straps: B-Line B2000, B2400; isolate copper pipe with two thicknesses of 2 inches wide 10-mil polyvinyl tape. Where used for seismic support systems, provide B-Line B2400 series pipe straps.
- e. Above Roof: H frame made from Uni-Strut hot-dipped galvanized 1-5/8 inch single or double channel with P-2072A or P-2073A foot secured to roof and surrounded with waterproof roofed in sleeper. Secure to sleeper with lag screws, and secure sleeper to blocking under roof.

5. Support to Structure:

- a. Wood Structure: Provide and install wood blocking as required to suit structure. Provide lag screws or through bolts with length to suit requirements, and with size (diameter) to match the size of hanger rods required.
 - 1) Do not install Lag screws in tension without written review and acceptance by Structural Engineer.

Side Beam Angle Clip	B-Line B3062	MSS Type 34
Side Beam Angle Clip	B-Line B3060	
Ceiling Flange	B-Line B3199	
 - 2) Blocking for support of piping shall be not less than 2 inch thick for piping up to 2 inch size (water filled) or 3 inch size (vapor filled). Provide 3 inch blocking for piping up through 5 inch size, and 4 inch blocking for larger piping. Provide support for blocking in accordance with Structural Engineers requirements.
 - 3) Where lag screws are used, length of screw shall be 1/2 inch less than the wood blocking. Pre-drill starter holes for each lag screw.

6. Rubber Neoprene Pipe Isolators:
 - a. Pipe isolators shall comprise an internal rubber or neoprene material that isolates pipe from hanger and structure. Install at all piping located in acoustical walls. Refer to Architectural Drawings for location of acoustical walls.
 - b. Isolation material shall be either a rubber or neoprene material that prevents contact between the pipe and the structure. The rubber shall have between a 45 to 55 durometer rating and a minimum thickness of 1/2 inch.
 - c. Acceptable Suppliers:
 - 1) Vertical runs: Acousto-Plumb or equal.
 - 2) Horizontal runs: B-Line, Vibraclamp; Acousto-Plumb or equal.
7. Provide support for piping through roof, arranged to anchor piping solidly in place at the roof penetration.
8. Provide rigid insulation and a 12 inch long, 18 gauge galvanized sheet iron shield between the covering and the hanger whenever hangers are installed on the outside of the pipe covering.
9. Insulate copper tubing from ferrous materials and hangers with two thicknesses of 3 inch wide, 10 mil polyvinyl tape wrapped around pipe.
10. Provide a support or hanger close to each change of direction of pipe either horizontal or vertical and as near as possible to concentrated loads.
11. Suspend rods from concrete inserts with removable nuts where suspended from concrete decks. Power actuated inserts will not be allowed.
12. On chilled or combination hot and chilled water or refrigerant pipes, install the hangers on the outside of the pipe covering and not in contact with the pipe. Provide rigid insulation and a 12 inch long, 18 gauge galvanized sheet iron shield between the covering and the hanger whenever hangers are installed on the outside of the pipe covering.

3.06 UNIONS AND FLANGES

- A. Install EpcO, Nibco, or equal, dielectric unions or flanges at points of connection between copper or brass piping or material and steel or cast iron pipe or material except in drain piping. Bushings or couplings shall not be used.
- B. Install unions in piping NPS 2" and smaller or flanges in piping NPS 2-1/2" and larger whether shown or not at each connection to all equipment and tanks, and at all connections to all automatic valves, such as temperature control valves.
- C. Locate the unions for easy removal of the equipment, tank, or valve.
- D. Do not install unions or flanges in refrigerant piping systems.

3.07 ACCESS DOOR

- A. Furnish and install access doors wherever required whether shown or not for easy maintenance of mechanical systems; for example, at concealed valves, strainers, traps, cleanouts, dampers, motors, controls, operating equipment, etc. Access doors shall provide for complete removal and replacement of equipment.

3.08 PIPE PROTECTION

- A. Wrap bare galvanized and black steel pipe buried in the ground and to 6" above grade, including piping in conduit, with one of the following, or equal:
 - 1. Polyethylene Coating: Pressure sensitive polyethylene coating, "X-Tru-Coat" as manufactured by Pipe Line Service Corporation or "Green Line" wrap as manufactured by Royston Products, or equal.
 - a. Field Joints and Fittings: Protecto Wrap #1170 tape as manufactured by Pipe Line Service Corporation, or Primer #200 tape by Royston Products, or equal. Installation shall be as per manufacturer's recommendation and instructions.
 - 2. Tape Wrap: Pressure-sensitive polyvinyl chloride tape, "Transtex #V-10 or V-20", "Scotchwrap 50", Slipknot 100, Pabco, or equal, with continuous identification. Tape shall be a minimum of 20 mils thick for fittings and irregular surfaces, two wraps, 50 percent overlap, 40 mils total thickness. Tape shall be laminated with a suitable adhesive; widths as recommended by the manufacturer for the pipe size. Wrap straight lengths of piping with an approved wrapping machine.
- B. Field Joints: Valves and Fittings: double wrap polyvinyl chloride tape as above. Provide at least two thicknesses of tape over the joint and extend a minimum of 4 inches over adjacent pipe covering. Build up with primer to match adjacent covering thickness. Width of tape of fittings shall not exceed 3 inches. Tape shall adhere tightly to all surfaces of the fittings without air pockets.
- C. Testing: Test completed wrap of piping, including all epoxy painted piping with Tinker and Rasor Co. test machine (San Gabriel, CA - 818-287-5259), Pipeline Inspection Company (Houston, TX - 713-681-5837), or equal.
- D. Cleaning: Clean all piping thoroughly before wrapping.
 - 1. Inspection: Damaged or defective wraps shall be repaired as directed. No wrapped pipe shall be covered until approved by Architect.
- E. Covering: No rocks or sharp edges shall be backfilled against the wrap. When backfilling with other than sand, protect wrap with an outer wrapping of Kraft paper; leave in place during backfill.

3.09 EXPANSION ANCHORS IN HARDENED CONCRETE

- A. Refer to Structural Drawings.
- B. Qualification Tests: The specific anchor shall have a current ICC-ES report and evaluated in cracked concrete in accordance with Acceptance Criteria AC193. The design shear and withdrawal load shall not be more than 80% of the allowable load listed in the current ICC-ES report and manufacturer's recommendations for the specific anchor.

- C. Installation: The anchors must be installed in accordance with the requirements given in ICC Research Committee Recommendations for the specific anchor.
- D. Testing: Fifty percent of the anchors shall be load-tested on each job to twice the allowable capacity in tension, except that if the design load is less than 75 pounds; only one anchor in ten need be tested. If any anchor fails, all anchors must be tested. The load test shall be performed in the presence of the project inspector.
- E. The load may be applied by any method that will effectively measure the tension in the anchor, such as direct pull with a hydraulic jack, a torque wrench calibrated using the specific anchor or calibrated spring-loading devices. Anchors in which the torque is used to expand the anchor without applying tension to the bolt may not be verified with a torque wrench.

3.10 TESTS AND ADJUSTMENTS

- A. Test the installations in accordance with the following requirements and all applicable codes:
 - 1. Inspector of Record should witness all tests of piping systems.
 - 2. Notify the Architect at least seven days in advance of any test.
 - 3. All piping shall be tested at completion of roughing-in, or at other times as directed by the Architect.
 - 4. Furnish all necessary materials, test pumps, gases, instruments and labor required for testing.
 - 5. Isolate from the system all equipment that may be damaged by test pressure.
 - 6. Make connections to existing systems with flanged connection. During testing of the new work, provide a slip-in plate to restrict test pressure to new systems only. Remove plate and complete connection to existing system at completion of testing.
 - a. Inspector of record shall witness final connection to system.
- B. Test Schedule: No loss in pressure or visible leaks shall show after four hours at the pressures indicated.

<u>System Tested</u>	<u>Test Pressure PSI</u>	<u>Test With</u>
Compressed Air, Acetylene and Oxygen	200 lb.	Air & Non-corrosive Leak Test Fluid
Gases and Vacuum	100	Air & Non-corrosive Leak Test Fluid
All Hot, Chilled, Combination, Condenser Water Piping	125	Water
Up to 15 psi Steam Piping and All Steam Condensate Piping	150	Water
Steam Piping Above 15 psi	300	Water

Fuel Oil	1-1/2 x WP & 20"	
Distilled Deionized Water	50	Water

1. Test all steam piping with nominal pressure steam before insulating.
 2. Flush distilled deionized water lines with distilled deionized water after test and approval.
 3. Non-corrosive leak test fluid shall be suitable for use with the piping material specified, and with the type of gas conveyed by the piping system.
- C. Perform operational tests under simulated or actual service conditions, including one test of complete plumbing installation with all fixtures and other appliances connected, and one test of complete installation of 48 hours each for heating and cooling with all equipment connected and operating.
- D. Should any material or work fail in any of these tests, it shall be immediately removed and replaced for new material, and portion of the work replaced shall again be tested by Contractor at his own expense.
- E. Lubricate each item of equipment, including motors, before operation.
- F. Testing, Evacuating, Charging and Lubrication of Refrigeration Systems:
1. Pressurize with dry nitrogen and/or refrigerant to 300 psig and test all joints with an electronic detector or halide torch. Release the pressure and attach a high vacuum pump. Evacuate to 4 mm (4000 microns) and hold for 30 minutes. Break to 5 psig with dry nitrogen and allow to remain in the system for ten minutes. Evacuate to 2 mm (2000 microns) and hold for 30 minutes. Use a mercury manometer or electronic vacuum gauge. Do not start timing until recommended vacuum range is reached.
 2. At the end of the evacuation, if the system has been proved leak-free, charge with refrigerant and fill the crankcase to the oil level specified by the manufacturer. All refrigerant oil shall be delivered to the location in sealed containers.
 3. Replenish for a period of one year without cost to the Owner all refrigerant and oil required to maintain the proper levels.

3.11 OPERATION OF SYSTEMS

- A. Do not operate any mechanical equipment for any purpose, temporary or permanent, until all of the following has been completed:
1. Complete all requirements listed under "Check, Test and Start Requirements."
 2. Ductwork and piping has been properly cleaned. Piping systems should be flushed and treated prior to operation.
 3. Filters, strainers etc. are in place.
 4. Bearings have been lubricated, and alignment of rotating equipment has been checked.

5. Equipment has been run under observation, and is operating in a satisfactory manner.
- B. Provide test and balance agency with one set of Contract Drawings, Specifications, Addenda, Change orders issued, applicable shop drawings and submittals and temperature control drawings.
- C. Operate every fire damper, smoke damper, combination smoke and fire damper under normal operating conditions. Activate smoke detectors as required to operate the damper, stage fan, etc. Provide written confirmation that all systems operate in a satisfactory manner.

3.12 TEMPORARY HEAT

- A. The General Contractor will provide for all temporary heat at such times as may be required or directed by the Architect and pay all fuel and energy costs incurred.
- B. Temporary heating facilities proposed for use by the Contractor will be subject to review of the Architect. Prior to use of any equipment for temporary heat, install temporary filters on all return air inlets, to preclude dust and construction debris from entering the duct system. In addition, install filters in air handling units, and replace at the completion of temporary operation.
- C. Filters used for temporary operation of systems shall be as specified for permanent filters specified herein.
- D. Comply with Check, Test and Start Requirements for start-up of equipment prior to operation for temporary heat.
- E. Heating Contractor shall complete the permanent heating system as soon as possible, thereby making it available for temporary heat. When available, the system may be used as required at the direction of the Architect after systems are properly prepared for use as specified elsewhere. Heating Contractor shall then be responsible for operating the system during periods required and the General Contractor shall pay the fuel and energy costs incurred. Operation of the heating system prior to the filing of "notice of completion" shall not change the Guarantee provisions in any way.

3.13 CHECK, TEST AND START REQUIREMENTS

- A. An authorized representative of the equipment manufacturer shall perform check, test and start of each piece of mechanical equipment. The representative may be an employee of the equipment manufacturer, or a manufacturer-certified contractor. Submit written certification from the manufacturer stating that the representative is qualified to perform the check test and start of the equipment.
 1. As part of the submittal process, provide a copy of each manufacturer's printed startup form to be used.
 2. Some items of specified equipment may require that check, test and start of equipment must be performed by the manufacturer, using manufacturer's employees. See specific equipment Articles in these Specifications for this requirement.
 3. Provide all personnel, test instruments, and equipment to properly perform the check, test and start work.
 4. When work has been completed, provide copies of reports for review, prior to final observation of work.

- B. Provide copies of the completed check, test and start report of each item of equipment, bound with the Operation and Maintenance Manual.
- C. Upon completion of the work, provide a schedule of planned maintenance for each piece of equipment. Indicate frequency of service, recommended spare parts (including filters and lubricants), and methods for adjustment and alignment of all equipment components. Provide a copy of the schedule with each Operation and Maintenance Manual. Provide a copy of certification from the Owner's representative indicating that they have been properly instructed in maintenance requirements for the equipment installed.

3.14 OWNER TRAINING

- A. An authorized representative of the equipment manufacturer shall train Owner-designated personnel in maintenance and adjustment of equipment. The representative may be an employee of the equipment manufacturer, or a manufacturer-certified contractor. Submit written certification from the manufacturer stating that the representative is qualified to perform the Owner training for the equipment installed.
 - 1. As part of the submittal process, provide a training agenda outlining major topics and time allowed for each topic.
 - 2. Some items of specified equipment require that training must be performed by the manufacturer, using manufacturer's employees. See specific equipment Articles in these Specifications for this requirement.
 - 3. Contractor shall provide three copies of certification by Contractor that training has been completed, signed by Owner's representative, for inclusion in Operation and Maintenance Manual. Certificates shall include:
 - a. Listing of Owner-designated personnel completing training, by name and title.
 - b. Name and title of training instructor.
 - c. Date(s) of training.
 - d. List of topics covered in training sessions.
 - 4. Refer to specific equipment Articles for minimum training period duration for each piece of equipment.

[END OF SECTION 23 00 50]

**SECTION 23 80 00
HEATING, VENTILATING AND AIR CONDITIONING**

PART 1 - GENERAL

1.01 SECTION INCLUDES

- A. Fans.
- B. Fume hood.
- C. Fume hood monitor.
- D. Relief and intake vents.
- E. Air inlets and outlets.
- F. Dampers.
- G. Ductwork.

1.02 RELATED DOCUMENTS

- A. Drawings and general provisions of the Contract, including General and Supplementary Conditions and Division 1 Specification Sections, apply to this Section.
- B. Section 23 00 50 Basic HVAC Materials and Methods.

1.03 ADDITIONAL REQUIREMENTS

- A. Furnish and install any incidental work not shown or specified which is necessary to provide a complete and workable system.
- B. Coordinate all of work in this Section with all of the Trades covered in other Sections of the Specifications to provide a complete, operable and sanitary installation of the highest quality workmanship.

1.04 DESCRIPTION OF WORK

- A. Work of this section includes, but is not necessarily limited to Heating, Ventilating and Air Conditioning work indicated on the drawings and described herein.

1.05 QUALITY ASSURANCE

- A. Design Criteria:
 - 1. All equipment and accessories to be the product of a manufacturer regularly engaged in its manufacture. All gas-fired equipment shall be UL, ETL or CSA listed.
 - 2. Supply all equipment and accessories in accordance with requirements of applicable national, state and local codes.

3. All items of a given type shall be products of the same manufacturer.
4. Scheduled equipment performance is minimum capacity required.
5. Scheduled electrical capacity shall be considered as maximum available.
6. Scheduled gas BTU input shall be considered as maximum available.

1.06 SUBMITTALS

- A. **Product Data:** Submit manufacturer's technical product data, including rated capacities of selected model clearly indicated, dimensions, weights, furnished specialties and accessories; and installation and start-up instructions. Product data shall include applicable product listings and standards.
 1. Upon approval of submittal, provide manufacturer's installation and operating instructions to the Project inspector for the following:
 - a. Fire dampers, smoke dampers, and combination smoke-fire dampers.
 - b. Type 1 kitchen exhaust field applied grease duct enclosures.
- B. **Roof Curb Data:** For roof mounted equipment where combined weight of equipment unit and roof curb or rail exceeds 400 pounds, submit calculations from manufacturer for roof curbs proving compliance with the seismic requirements of the 2010 CBC, and ASCE 7-05. Manufacturer shall certify that roof curbs are suitable for use indicated on Drawings and in Specifications for the seismic design category indicated in structural Contract Documents. Calculations shall be stamped and signed by a State of California registered structural engineer.
- C. **Engineering Data:** Submit fan curves and sound power level data for each fan unit. Data shall be at the scheduled capacity. Data shall include the name of the rating agency or independent laboratory.
- D. **Maintenance Data:** Submit maintenance data and parts list for each piece of equipment, control, and accessory; including "trouble-shooting guide," in Operation and Maintenance Manual.
- E. **Record Drawings:** At project close-out, submit Record Drawings of installed ductwork, duct accessories, and outlets and inlets in accordance with requirements of Division 1.
- F. **Special Seismic Certification:** Submit certification that [roof mounted air conditioning units] [roof mounted heat pumps] [split system AC units] [split system heat pumps] [fans] [other equipment] will withstand seismic forces indicated in Contract Documents. Include the following:
 1. OSHPD Special Seismic Certification Pre-Approval (OSP) number and back-up data.
 - a. Back-up data shall include copy of OSHPD form OSH FDD 735, "Application for Pre-Approval," signed by OSHPD representative.
 - b. If compliance is achieved by alternate method approved by OSHPD, provide document indicating compliance method. Include back-up data. IBC Certification is not an acceptable alternate compliance method.

2. Letter from equipment manufacturer indicating:
 - a. The equipment manufacturer has reviewed seismic forces indicated in Contract Documents and that seismic forces utilized in testing equipment and obtaining an OSP number meet or exceed Project requirements.
 - b. The manufacturer shall indicate that submitted equipment with OSP number meets criteria in Contract Documents, including features, options, dimensions, weights, anchorage devices, etc. Include Specification Section article reference number or Drawing sheet number with reference to physical location of equipment. If submitted equipment with OSP number does not meet these requirements, the letter shall contain detailed list noting variances from the product specified in Contract Documents.
 3. Dimensioned Outline Drawings of Equipment Unit: Identify center of gravity and locate and describe mounting and anchorage provisions.
 4. Detailed description of equipment anchorage devices on which the certification is based and their installation requirements.
- G. Product Data for California Green Building Standards Code Compliance: For adhesives and sealants, including primers, documentation of compliance including printed statement of VOC content and chemical components.
- H. LEED Submittals:
1. Product Data for Credit EQ 4.1: For adhesives and sealants, documentation of compliance including printed statement of VOC content and chemical components.
 2. Laboratory Test Reports for Credit EQ 4: For adhesives and sealants, documentation indicating that product complies with the testing and product requirements of the California Department of Health Services' "Standard Practice for the Testing of Volatile Organic Emissions from Various Sources Using Small-Scale Environmental Chambers."

1.07 COORDINATED LAYOUT

- A. Coordinated layouts are required to amplify, expand and coordinate the information contained in the Contract Documents.
- B. Provide minimum 1/4 inch equals one foot scaled coordination drawings showing plan and pertinent section or elevation views of all piping, ductwork and electrical systems. Drawings shall be on vellum or sepia mylar, reproducible and the work represented shall be fully coordinated with the structure, other disciplines, and with all finishes. Drawings shall all be presented on a single size sheet. Contractor may use either size D (24 inch x 36 inch) or E (36 inch x 42 inch). Drawings graphics shall fully comply with A.I.A. Architectural Graphic Standards and ANSI Y14. Drawings may be hand drawn or computer generated using AutoCad or "Quick Pen". All drawings shall have title block, key plan, north arrow and sufficient grid lines to provide cross-reference to the design drawings.
 1. Provide a stamp or title block on each drawing with locations for signatures from all contractors involved, including but not limited to the General, HVAC, Plumbing, Fire

Protection, and Electrical contractors. Include statement for signature that the contractor has reviewed the coordination drawings in detail and has coordinated the work of his trade.

2. Show on drawings the intended elevation of all ductwork in accordance with the following example.
 3. B.O.D. = 9'-0"
 4. OFFSET UP 6"
 5. B.O.D. = 9'-6"
 6. Highlight, encircle or otherwise indicate deviations from the Contract Documents on the coordinated layouts. Architect will not be responsible for "finding" changes or deviations to the original Contract Documents.
- C. Since scale of contract drawings is small and all offsets and fittings are not shown, contractor shall make allowances in bid for additional coordination time, detailing, fittings, offsets, hangers and the like to achieve a fully coordinated installation. If changes in duct size are required, equivalent area shall be maintained and the aspect ratio shall not be in excess of 2 to 1 unless approved by the engineer. Drawings shall be submitted for review prior to fabrication and installation. Drawings may be submitted in packages representing at least one quarter of the building ductwork.
- D. Check routing on all ductwork before fabricating. Report any discrepancies to Architect. No extra cost will be allowed for failure to conform to above.
- E. It shall be responsibility of the General Contractor to ensure that the Heating, Ventilating and Air Conditioning Contractor coordinates all of his work with all other trades, including mechanical and electrical trades, so that complete job is neat and in conformity with plans and specifications.
- F. Where computer aided drafting has been used for the Contract Documents, the Drawing files may be made available. Upon request by the contractor, the files will be made available at a price of **\$50** per drawing, with a minimum of \$200.00 per request.

1.08 REFERENCES

- A. AABC - Associated Air Balance Council
- B. AFBMA - Anti Friction Bearing Manufacturer's Association
- C. CSA – Canadian Standards Association International
- D. AMCA - Air Moving and Control Association Inc.
 1. Standard 210 - Laboratory Methods of Testing Fans
- E. ANSI - American National Standards Institute
- F. ARI - Air-Conditioning and Refrigeration Institute

- G. ASHRAE - American Society of Heating, Refrigerating and Air Conditioning Engineers
- H. ASME - American Society of Mechanical Engineers
- I. ASTM - American Society of Testing and Materials
- J. CCR - California Code of Regulations
- K. CSFM - California State Fire Marshal
- L. NIST - National Institute of Standards and Technology
- M. NEMA - National Electrical Manufacturer's Association
- N. NFPA - National Fire Protection Association
- O. OSHA - Occupational Safety and Health Act
- P. SMACNA - Duct Manuals
- Q. CBC - California Building Code
- R. UL - Underwriters' Laboratories, Inc.
- S. CMC - California Mechanical Code
- T. CPC - California Plumbing Code
- U. CEC - California Electrical Code

PART 2 - PRODUCTS

2.01 MATERIALS

- A. Insulation products, including insulation, insulation facings, jackets, adhesives, sealants and coatings shall not contain polybrominated diphenyl ethers (PBDEs) in penta, octa, or deca formulations in amounts greater than 0.1 percent (by mass).

2.02 FANS

- A. All fans shall be Air Moving and Control Association Inc. (AMCA) labeled.
- B. Provide self-aligning, enclosed ball bearings, accessible for lubrication unless specified otherwise.
- C. Provide variable speed switch for all direct drive fans.
- D. Roof Mounted:
 - 1. Direct or V-belt Drive: Provide one-piece heavy-duty ventilator housings, one piece heavy gauge spun aluminum construction, with weatherproof assembly and integral

weather shield. Mount ventilators on curbs furnished by the fan manufacturer. Install with fan assembly level.

2. Fan wheels shall be centrifugal design, statically and dynamically balanced. Tip speed, rpm and motor horsepower shall not exceed listing in manufacturer's catalog for unit specified.
3. Fans shall have integral factory formed base and one piece spinning without welding. Housings shall be provided with wiring channel and are to be of the direct discharge design. Motor and fan assembly shall be on vibration isolating mounts. Fans shall have capacity, speeds and motor sizes as shown.
4. Provide the following accessories:
5. Gravity backdraft dampers
6. Aluminum bird screen with a minimum of 85 percent free area
7. Adjustable motor pulley
8. Laboratory fume hood exhaust fans shall be Keysite coated.

E. Ceiling Mounted Fans:

1. Acoustic lined cabinet, built-in back draft damper, vibration isolated fan and motor, variable speed switch.
2. Provide sloped roof or flat roof type roof cap, or wall cap to suit the location indicated on the Drawings.

F. Fan Drives:

1. Drive Design: The design horsepower rating of each drive shall be at least 1.5 times, single belt drives 2 times, the nameplate rating of the motor with proper allowances for sheave diameters, speed ratio, arcs of contact and belt length.
2. Provide variable speed drives, Dayco, Browning, Woods, or equal. Allow for replacement of fan and motor drives and belts as required to suit the balance requirements of the project.
3. Provide a minimum of two belts for all drives with motors 5 horsepower motors and larger.
4. Belts shall be within 1 degree 30 minutes of true alignment in all cases.
5. Select variable speed drives to allow an increase or decrease of minimum of ten percent of design fan speed.
6. Motors of 25 HP and less shall have adjustable pitch sheaves; sheaves on motors above 25 HP may be non-adjustable. Change, at no extra cost to Owner, the non-adjustable sheaves to obtain desired air quantities.

- G. Sheaves: Sheaves shall be cast or fabricated, bored to size or bushed with fully split tapered bushings to fit properly on the shafts. All sheaves shall be secured with keys and set screws.
- H. Belts: All belts shall be furnished in matched sets.
- I. Manufacturers: Subject to compliance with requirements, available manufacturers offering products that may be incorporated into the Work include the following, or equal:
 - 1. Greenheck Fan Corporation
 - 2. Loren Cook Company
 - 3. PennBarry
 - 4. American Coolair Corporation
- J. Owner Training: Manufacturer shall provide one on-site 1-hour training session for Owners' maintenance personnel.

2.03 FUME HOOD

- A. Fisher Hamilton Fume Hood Model No 54L2825P0-P-S-Bor equal, ADA accessible. Refer to architectural drawings for base details and base specification.
- B. General:
 - 1. Fume hoods shall function as ventilated, enclosed workspaces, designed to capture, confine and exhaust fumes, vapors and particulate matter produced or generated within the enclosure.
 - 2. Design fume hoods for consistent and safe air flow through the hood face. Negative variations of face velocity shall not exceed 20% of the average face velocity at any designated measuring point as defined in this section.
 - 3. Average illumination of work area: Minimum 80 footcandles. Work area shall be defined as the area inside the superstructure from side to side and from face of baffle to the inside face of the sash, and from the working surface to a height of 28 inches.
 - 4. Fume hood shall be designed to minimize static pressure loss with adequate slot area and bell shaped exhaust collar configuration. Maximum average static pressure loss readings taken three diameters above the hood outlet from four points, 90 degrees apart, shall not exceed the following maximums with sash in full open position:
 - 5. Face Velocity Measured S.P.L. (W.G.)
 - 6. 75 F.P.M. .18 inches
 - 7. 100 F.P.M. .30 inches
 - 8. 125 F.P.M. .45 inches

9. 150 F.P.M. .60 inches
10. Fume hood shall maintain essentially constant exhaust volume at any baffle position for safety. Maximum variation in exhaust CFM, static pressure and average face velocity as a result of baffle adjustment shall not exceed 5% for any baffle position at the specified face velocity.
11. Fume hoods shall be field convertible, from bypass type to auxiliary air by simple component replacement or addition. Change-over shall be accomplished without construction modifications and without special tools.
12. Noise Criteria: Test data of octave band analysis verifying hood is capable of a 50 NC value when connected to a 50 NC HVAC source. Reading taken 3' in front of open sash at 100 fpm face velocity.

C. Fume Hood Materials:

1. Steel: High quality, cold rolled, mild steel meeting requirements of ASTM A366; gauges U.S. Standard and galvanized.
2. Stainless steel: Type 304; gauges U.S. Standard.
3. Ceiling closure panels: Minimum 18 gauge; finish to match hood exterior.
4. Bypass grilles: Low resistant type, 18 gauge steel, upward directional louvers.
5. Safety glass: 7/32" thick laminated safety glass.
6. Sash cables: Stainless steel, uncoated, 1/8" diameter military spec. quality. (MIL-W-83420D-3)
7. Sash guides: Corrosion resistant poly-vinyl chloride.
8. Pulley assembly for sash cable: 2" diameter, zinc dichromate finish, ball bearing type, with cable retaining device. (Nylon tired-not acceptable.)
9. Sash pull: Full width corrosion resistant plastic, stainless steel or steel with chemical resistant powder coating.
10. Gaskets: 70 durometer PVC for interior access panels. Gasket interior access panels to eliminate air leakage and to retain liquids inside hood.
11. Fastenings:
 - a. Exterior structural members attachments: Sheet metal screws, zinc plated.
 - b. Interior fastening devices concealed. Exposed screws not acceptable. (Screw head "caps" not acceptable.)
 - c. Exterior panel member fastening devices to be corrosion resistant, non-metallic material. Exposed screws not acceptable.

- D. Instruction plate: Corrosion resistant or plastic plate attached to the fume hood exterior with condensed information covering recommended locations for apparatus and accessories, baffle settings and use of sash.
- E. Superstructure: Rigid, self supporting assembly of double wall construction, maximum 4-7/8" thick.
1. Wall consists of a sheet steel outer shell and a corrosion resistant inner liner, and houses and conceals steel framing members, attaching brackets and remote operating service fixture mechanisms and services. Panels must be attached to a full frame construction, minimum 14 gauge galvanized members. Panels and brackets attached to eliminate screw heads and metallic bracketry from hood interior.
 2. Access to fixture valves concealed in wall provided by exterior removable access panels, gasketed access panels on the inside liner walls, or through removable front posts.
- F. Exhaust outlet: Rectangular with ends radiused, shaped and flanged, 18 gauge [stainless steel exhaust collars welded in place.
- G. Access opening perimeter: Air foil or streamlined shape with all right angle corners radiused or angled. Bottom horizontal foil shall provide nominal one inch bypass when sash is in the closed position and relatively flush with the top of the work surface. Bottom foil shall be removable without use of special tools. Bottom foil shall provide access areas for electrical cords. Bottom foil: Steel with urethane powder coating I to increase acid and abrasion resistance.
- H. Fume hood sash: Full view type with clear, unobstructed, side-to-side view of fume hood interior and service fixture connections. Two vertically rising sashes with recessed pulls (one each side).
1. Bottom sash rail: 2" maximum, 18 gauge steel with urethane powder coat finish. Provide integral formed, flush pull the full width of bottom rail.
 2. Set safety glass into rails in deep form, extruded poly-vinyl chloride glazing channels.
 3. Counter balance system: Single weight, pulley, cable, counter balance system which prevents sash tilting and permits one finger operation at any point along full width pull. Maximum 7 pounds pull required to raise or lower sash throughout its full length of travel. Design system to hold sash at any position without creep and to prevent sash drop in the event of cable failure. Life cycle test 100 pound sash and weight to 100,000 cycles without sign of failure. Provide independent test data.
 4. Postless sash design: Per drawing details.
 5. Open and close sash against rubber bumper stops.
 6. Provide with sash interlock 90L162NO allowing only one sash to be opened at a time.
 7. Fume hood liner: Poly-resin (product number denoted by the suffix "P"): Reinforced polyester panel; smooth finish and white color in final appearance. Flexural strength: 14,000 psi. Flame spread: 25 or less per U.L. 723 and ASTM E84-80.

- I. Baffles: Baffles providing controlled air vectors into and through the fume hood must be fabricated of the same material as the liner. Provide exhaust slots full height on vertical sides of the baffle with upper slots adjustable. All baffle supports/brackets to be non-metallic. Baffles shall be fixed position.

- J. Service fixtures and fittings: Color coded washers at hose nozzle outlets and valves mounted inside the fume hood and controlled from the exterior with color coded index handles.
 - 1. Valves: Needle point type with self-centering cone tip and seat of hardened stainless steel. Tip and seat shall be removable and replaceable.
 - 2. Provide piping for all service fixtures from valve to outlet: Galvanized iron or copper for water, air and vacuum and black iron for gas services.
 - 3. Fixtures exposed to hood interior: Brass with chemically resistant black powder coating.
 - 4. Remote control handles: Black nylon four-arm handle with nylon color-coded index buttons.
 - 5. Services: As shown or specified.

- K. Service fixtures and fittings:
 - 1. Service treatment: Fittings are to be coated with a chemically resistant polyester powder lacquer electrostatically applied and backed on for a uniform finish.
 - 2. Handle and outlet nozzle will be color coded to the media, with the same polyester powder lacquer finish. Handles shall be metal with media identification text. Outlet nozzles shall be made of the same high quality brass as the valve bodies. Other materials may be in contact with media where appropriate.
 - 3. Provide piping for all service fixtures from valve to outlet: Galvanized iron or copper for water, air and vacuum and black iron for gas services.
 - 4. Fixture fittings shall incorporate quick-connect compression fittings on the valve body (for the media inlet and media outlet) as well as the fume hood outlet nozzle. With this system, no soldering or brazing should be required to complete mechanical connections.
 - 5. Fixtures exposed to fume hood interior. Brass with chemically resistant polyester powder lacquer color coded to the media.
 - 6. Fixtures are to be provided with easy-to-mount attachment device for secure mounting in deck or wall mounted applications. System to be installed with simple hand tools.
 - 7. Fittings are to be constructed to operate with the following maximum working pressure without leak or failure.
 - 1) Water Fittings: 145 PSI
 - 2) Burning Gases: 100 PSI

8. All outlets shall have detachable serrated nozzles.
 9. All valves shall be front-loaded for ease of access and maintenance at point of use.
- L. Hood light fixture: Two lamp/T8, rapid start, UL listed fluorescent light fixture with sound rated ballast mounted on each side of fume hood. Provide safety glass panel cemented and sealed to the hood roof.
1. Interior of fixture: White, high reflecting plastic enamel.
 2. Size of fixture: Largest possible up to 48" for hoods with superstructures up to six feet. Provide two 36" fixtures for hoods with eight foot superstructures.
 3. Include lamps with fixtures.
 4. Illumination: Per performance values per Part B of this Section.
- M. Electrical services: Three wire grounding type receptacles rated at 120 V.A.C. at 20 amperes. Provide 250 V.A.C. receptacles where specified. Flush plates: Black acid resistant thermoplastic.
- N. Work surfaces: [Specified Option] 1-1/4" thick surface, dished a nominal one-half inch to contain spills.
1. Molded resin work surfaces for hoods with Poly-resin liners.
- O. Safety Monitor/Alarm System: Provide Safety Monitor/Alarm System which monitors face velocity and provides audible and visual alarm if face velocity drops below safe levels. The technology used in the **54LAF500** and the **54LAF1000** will be based on thermally compensated thermistor based in the alarm module. As the internal fume hood pressure changes as the sash opening is closed and opened, the flow passing over the thermistor is calibrated to a face velocity which is displayed on the front of the monitor.
1. Safety monitor: UL listed, tamper proof, with all alarm circuits, electric components, external tubing, and manifolds furnished complete and factory installed. The monitor shall have light emitting diode display which provides clear indication of airflow conditions.
 2. Calibration is the responsibility of the owner and is required once the hood is stationed and the hood exhaust and room supply systems are balanced. A secondary calibration has been factory set into the alarm's memory only to determine that the alarm is functional and ready for shipment. **The primary calibration must be completed in the field.**
 3. Airflow sensor: Thermally compensated glass-beaded thermistor, factory connected to a side-wall port on the interior of the fume hood.
 4. Alarm Signal: Audible signal and a visual, red large light emitting diode:
 - a. Silence pushbutton, which disables the audible alarm, shall be accessible on the front of the safety monitor.

- b. Provide alternate mode in which audible alarm is silenced indefinitely but visual alarm remains activated until the alarm condition is corrected.
 - c. When alarm condition is corrected and face velocity and volume return to specified levels, the Safety Monitor will automatically reset and begin routine monitoring.
- 5. Provide test circuit to verify proper Safety Monitor operation.
 - 6. Electrical rating: Maximum 12 VDC, and maximum current rating of 200MA.

2.04 RELIEF AND INTAKE VENTS

- A. Galvanized steel housing with 1/2 inch mesh screen, counterbalanced backdraft damper and matching prefabricated curb. Omit backdraft damper on intake vents. Provide pitched roof curb for relief vents, and install with backdraft damper level.
- B. Manufacturers: Subject to compliance with requirements, available manufacturers offering products that may be incorporated into the Work include the following, or equal:
 - 1. Greenheck Fan Corporation.
 - 2. Lauren Cook Company.
 - 3. PennBarry.
 - 4. American Coolair Corporation.

2.05 AIR INLETS AND OUTLETS

- A. Except as otherwise indicated, provide manufacturer's standard outlets and inlets where shown; of size, shape, capacity and type indicated; constructed of materials and components as indicated, and as required for complete installation.
- B. Ceiling, wall or floor Compatibility: Provide outlets with border styles that are compatible with adjacent ceiling, wall or floor systems, and that are specifically manufactured to fit into ceiling, wall or floor module with accurate fit and adequate support. Refer to general construction drawings and specifications for types of ceiling systems that will contain each type of air outlet and inlet.
- C. Refer to Schedule on Mechanical Drawings for details of inlets and outlets to be used.

2.06 DAMPERS

- A. Backdraft Dampers: Ruskin CBD2, counterbalanced, Nailer Industries, or equal.
- B. Manual Air and Balance Dampers: Provide dampers of single blade type or multi-blade type constructed in accordance with SMACNA, "HVAC Duct Construction Standards," except as noted herein.
 - 1. Rectangular Ductwork:

- a. Single damper blades may be used in ducts up to 10 inches in height. Dampers shall be 16 gauge minimum. Provide self-locking regulators, equal to Ventlok 641. Provide end bearings equal to Ventlok 607 at each damper. Provide continuous solid 3/8 inch square shafts.
- b. Multiple blade dampers shall be equal to Ruskin CD35 Standard Control Damper. Maximum width for multiple damper blades for use in rectangular duct shall not exceed 6 inches.
- c. Where duct velocity may be expected to exceed 1500 fpm, provide Ruskin CD-50, or equal, low leakage dampers with airfoil blades.

2. Round Ductwork:

- a. Single damper blades may be used in ducts up to 12 inches in diameter. Provide multiple blade opposed blade dampers, with connected linkage, for ductwork larger than 12 inches in diameter.
- b. Damper blades for round ductwork shall be 20 gauge steel for ducts up to 12 inches diameter and 16 gauge steel for dampers larger than 12 inches diameter. Provide self-locking regulators, equal to Ventlok 641, Durodyne, or equal for operation of dampers. Provide end bearings equal to Ventlok 607 and provide continuous solid 3/8 inch square shafts.

3. Where ductwork is externally insulated, provide self-locking regulators equal to Ventlok 644, Durodyne, or equal for rectangular ductwork, and Ventlok 637, Durodyne, or equal for round ducts.

C. Fire Dampers and Combination Fire/Smoke Dampers:

1. Fire dampers and combination fire/smoke dampers shall be listed and approved by the California State Fire Marshal. Installation shall conform to the manufacturer's UL approved installation instructions.
 - a. Fire dampers shall be UL 555 classified and labeled as dynamic fire dampers approved for wall and floor installation. They shall ship from the manufacturer as an assembly with a minimum 20-gauge factory installed sleeve. Sleeve length shall suit the requirements of the wall construction. Each dynamic fire damper/sleeve assembly shall ship complete with factory "roll formed" one-piece angles with pre-punched holes for easy installation. Dynamic fire dampers for vertical installation must consist of a single section on sizes up to 33" x 36" and a single section on sizes up to 24" x 24" for horizontal installation. 1-1/2 hour dynamic fire dampers shall be Ruskin DIBD20, Pottorff. 3 hour dynamic fire dampers shall be Ruskin DIBD230, Pottorff.
 - b. Fire dampers for high pressure/velocity systems where velocities exceed 2000 fpm and/or 4" w.g. pressure fire damper shall be Ruskin FD60 or equal by Pottorff.
 - c. Fire dampers for ceiling installation shall be UL 555C classified and labeled as ceiling dampers. They shall be provided with a thermal insulating blanket to fit the inlet or outlet condition if required by the application. Ceiling dampers shall

be Ruskin CFD 2, 3, 4 or 5. Ceiling dampers for ceilings constructed of wood shall have UL tested in design L501 and shall be Ruskin CFD7, equal by Pottorff.

- d. Combination fire/smoke dampers. Dampers shall be UL classified and labeled as Leakage Class I Smoke Dampers in accordance with the latest version of UL 555S. Dampers shall be warranted to be free from defects in material and workmanship for a period of 5 years after date of shipment. Damper/actuator assembly shall be tested to full open and full close at minimum 2000 fpm 250° F heated air and 4" w.g. with airflow in both directions. (Specified select: 250° / 350°, 2000 fpm/3000 fpm). Each damper shall be equipped with EZ reset "controlled closure" quick detect heat actuated release device to prevent duct and HVAC component damage resulting from instantaneous damper closure. Release device shall be EFL type and shall allow easy reset from outside the sleeve after moderate temperature exposure. (Replacement type fusible links not acceptable.)
- e. Two position combination fire smoke dampers shall be equipped with one or more factory installed, direct coupled, 120 volt, single phase, electric actuator for energize open – fail close operation. Dampers with multiple actuators shall be factory wired with single point connection at the EFL heat release device for connection to poser. Damper actuator shall include minimum one-year energized hold open (no cycles) and spring return (fail) close reliability. Damper/actuator shall include minimum 20,000 full open-full close cycle performances.
- f. Round combination fire smoke dampers up to 24" diameter shall be true round type with minimum 2- gauge minimum galvanized designed for lowest pressure drop and noise performance. Bearings shall be stainless steel sleeve turning in an extruded hole in the frame. Blade seals shall be silicone edge designed to withstand 450° F and galvanized steel mechanically locked in to the blade edge (adhesive type seals are not acceptable). Each damper shall be equipped with a factory-installed sleeve of 17" minimum length and factory "roll formed" one-piece angles with pre-punched holes for easy installation. Dampers shall be Ruskin FSD60 or equal by Pottorff.
- g. Round (larger than 24" diameter) or rectangular combination fire smoke dampers shall include roll-formed structural hat channel frame, reinforced at the corners, formed from a single piece of minimum 16 gauge equivalent thickness formed from single piece galvanized steel. Bearings shall be stainless steel turning in an extruded hole in the frame. Blade edge seals shall be silicone rubber designed to withstand 450° F and galvanized steel mechanically locked in to the blade edge (adhesive type seals are not acceptable). Each damper shall be equipped with a factory-installed sleeve of 17" minimum length and factory "roll formed" one-piece angles with pre-punched holes for easy installation. Dampers shall be Ruskin FSD60 or equal by Pottorff.
- h. All FSD60 type dampers shall be AMCA licensed and shall bear the AMCA Seal for Air Performance. AMCA certified testing shall verify pressure drop does not exceed .03" w.g. at a face velocity of 1,000 fpm on a 24" x 24" damper.
- i. Wall type fire/smoke damper:

- 1) Combination fire/smoke dampers for use in the wall of exit corridors shall be classified and labeled as Leakage Class II Smoke Dampers in accordance with the latest version of UL 555S. Dampers shall meet the requirements for combination fire/smoke dampers in paragraph 3 above except AMCA certified testing shall verify pressure drop does not exceed .07" w.g. at a face velocity of 1,000 fpm on a 24" x 24" damper and blades shall be single skin galvanized steel 10 gauge minimum with 3 longitudinal grooves for reinforcement. Dampers shall be Ruskin FSD36 or equal by Pottorff.
- 2) Front access combination fire/smoke dampers shall meet all the requirements for combination fire/smoke dampers in paragraph 3 above except pressure drop requirement. In addition the dampers shall be constructed so that actuators and all accessories are accessible from the grille side. Actuators and accessories shall be housed within an integral cabinet on the side of the damper frame and shall not be installed in the air stream in front of the damper. The damper sleeve shall be minimum 14" and flanged to accept a steel framed grille. The sleeve shall be covered with fire resistant material. Dampers shall be Ruskin FSD60FA or equal by Pottorff.
- j. Ceiling type fire/smoke damper for tunnel type corridor construction: Combination fire/smoke dampers for use in the corridor ceiling of tunnel type corridor construction shall be UL classified and labeled as Corridor Damper. Dampers shall meet the requirements of paragraph 4a above except pressure drop testing does not require AMCA certification. Dampers shall be Ruskin FSD36C or equal by Pottorff.
- k. Fusible links shall have temperature rating approximately 50° F above normal maximum operating temperature of the heat producing appliance.
 - 1) If project requires re-openable fire/smoke dampers, provide Ruskin 165 ° F / 350° F TS150, NCA or equal. The TS150 firestat replaces the EFL and allows the damper to be re-opened from remote location up to 350 ° F. TS150 shall include full open and full closed damper position contacts for interface with remote position indication panel.
 - 2) Each fire/smoke damper shall be quipped with "controlled closure" quick detect heat actuated release device to prevent duct and HVAC component damage. Release device shall allow easy reset after moderate temperature rise outside the sleeve. Heat release device shall be the Ruskin EFL, NCA or equal.
 - 3) Unless the system is using a validation control system (see section 15820), each fire/smoke damper shall be equipped with a control panel including blade position indicator lights and a key operated switch. The panel cover shall be oversized for flush mount into the wall or ceiling and shall have a brushed look. Control panel shall be Ruskin MCP2, or equal by Pottorff.
2. Fusible links shall have temperature rating approximately 50 degrees F. above normal maximum operating temperature of the heat producing appliance.

3. Where required to suit the size of damper required, provide manufacturers standard UL Classified mullions, arranged to support multiple dampers. Assembly shall be minimum of 16 gauge galvanized steel, complete with all accessory caps and framing members required for installation. Provide independent motor and operator as required for each individual damper, arranged to suit UL Classification requirements.
4. All actuators used for smoke dampers or combination fire/smoke dampers shall have a cycle time requirement of no more frequently than every twelve months and shall be rated for continuous "On" duty and shall be provided with internal spring return. Actuators shall be equipped with pilot light, remote key test switch, end switch and circuitry to activate pilot light on remote key (test) switch located in corridor ceiling adjacent to damper. Electric motors shall be Invensys MA-250, MA-253, Honeywell H2000, or equal.

2.07 DUCTWORK

- A. Construct and install all sheet metal ductwork in accordance with the 2010 California Mechanical Code for 2 inches static pressure for supply air, and 2 inches minimum for return and exhaust air unless otherwise noted on Drawings.
 1. Where not in conflict with the California Mechanical Code, construct and install all sheet metal ductwork in accordance with SMACNA HVAC Duct Construction Standards (Metal and Flexible). Where applicable for HVAC work, construct and install sheet metal work in accordance with SMACNA Architectural Sheet Metal Manual.
 2. Provide variations in duct size, and additional duct fittings as required to clear obstructions and maintain clearances as approved by the Architect at no extra cost to the Owner.
 3. Gauges, joints and bracing shall be in accordance with the 2010 California Mechanical Code.
 4. Provide beading or cross breaking for all ductwork inside building. Provide cross breaking for ductwork exposed to weather.
 5. At the contractor's option, ductwork may be fabricated using the Ductmate, Nexus, Quickduct, Transverse Duct Connection (TDC), Pyramid-Loc duct connection systems, or equal. Fabricate in strict conformance with manufacturer's written installation instructions and in accordance with California Mechanical Code.
 - a. Seal flanged ends with pressure sensitive high density, closed cell neoprene or polyethylene tape gasket, Thermo 440, or equal.
 - b. Provide metal clips for duct connections, except at breakaway connections for fire dampers and fire smoke dampers. Provide corner clips at each corner of duct, through bolted, at all locations except at breakaway connections for fire dampers and fire smoke dampers. Where used on locations exposed to weather, provide continuous metal clip at top and sides of duct, with 1 inch overhang for top side.
- B. Design and installation standards:

1. SMACNA Compliance: Comply with applicable portions of Sheet Metal and Air Conditioning Contractor's National Association (SMACNA) for all work in this section.
 2. ASHRAE Standards: Comply with American Society of Heating, Refrigerating and Air Conditioning Engineers, Inc. (ASHRAE) recommendations, 1985 edition, for all work in this section.
 3. NFPA Compliance: Comply with ANSI/NFPA 90A, "Standard for the Installation of Air Conditioning and Ventilating Systems," and ANSI/NFPA 90B, "Standard for the Installation of Warm Air Heating and Air Conditioning Systems."
 4. California Mechanical Code 2010 edition.
 5. ADC Test Code FD 72-RI, Flexible Air Duct Test Code.
 6. NFPA 90-A, Standard for the Installation of Air Conditioning and Ventilating Systems, latest edition.
- C. Fabricate all ductwork with sheet metal. Fiberglass ductwork will not be accepted for use on this project.
- D. Duct sizes indicated are external sizes.
- E. Galvanized Sheet Steel: Lock-forming quality, ASTM A924 and ASTM A653, Coating Designation G 90. Provide mill phosphatized finish for exposed surfaces of ducts exposed to view.
1. Provide mill certification for galvanized material at request of the IOR.
- F. Duct Sealing:
1. Sealant shall have a VOC content of 250 g/L or less.
 2. Sealant shall comply with testing and product requirements of South Coast Air Quality Management District, Rule 1168.
 3. Seal airtight all joints and seams, including standing seams and manufactured joints and seams, of all supply, return and exhaust ducts except those exposed in the conditioned space. Provide one part, non-sag, synthetic latex sealant, formulated with a minimum of 68 percent solids. Sealant shall comply with ASTM E84, Surface Burning Characteristics.
 - a. Manufacturers: Subject to compliance with requirements, available manufacturers offering products that may be incorporated into the Work include the following, or equal:
 - b. Design Polymerics, model DP1010
 - c. Polymer Adhesive Sealant Systems Inc, model Airseal #11
 - d. McGill Airseal, LLC

4. Seal airtight and watertight joints and seams of ductwork exposed to weather with 6 ounce canvas bonded to ductwork with Foster 30-36 adhesive; cover canvas with heavy coat of Foster 56-10 coating, no dilution. Provide basis of design product or equal by Mon-Eco Industries, Inc., or McGill Airseal, LLC.
 - a. Pressure-sensitive tapes or single part sealant not acceptable.
 - b. Where seams are exposed to weather, paint seams with aluminum paint. Provide cross broken ductwork, and ensure that the ductwork will shed water. Beading of duct work will not be considered.

G. Provide sheet metal angle frame at all duct penetrations to wall, floor, roof, or ceiling.

H. Duct Support Materials: Except as otherwise indicated, provide hot-dipped galvanized steel fasteners, anchors, straps, trim, and angles for support of ductwork.

I. Rectangular Duct Fabrication:

1. Shop fabricate ductwork of gauges and reinforcement complying with the more stringent of the following standards, except as noted herein.
 - a. SMACNA HVAC Duct Construction Standards
 - b. California Mechanical Code
2. Fabricate ducts with minimum duct gauges and reinforcement as follows, except as otherwise noted:

3.	Duct Dimensi on	4.	Minimum Gauge	5.	Jo Re rc nt Cl
6.	Through 12"	7.	26	8.	Ne Re re
9.	13" through 18"	10.	24	11.	Ne Re re
12.	19" through 30"	13.	24	14.	C/
15.	31" through 42"	16.	22	17.	E/
18.	43"	19.	22	20.	F/

	through 54"				
21.	55" through 60"	22.	20	23.	G.
24.	61" through 84"	25.	20	26.	I/2
27.	85" through 96"	28.	20	29.	J/
30.	Over 96"	31.	18	32.	K/

33. Fabricate duct fittings to match adjoining ducts and to comply with duct requirements as applicable to fittings. Except as otherwise indicated, fabricate elbows with center-line radius equal to 1.5 times associated duct width. Fabricate to include single thickness turning vane in elbows where space does not permit the above radius or where square elbows are shown. Limit angular tapers to 30 degrees for contracting tapers and 20 degrees for expanding tapers. Turning vanes shall be E-Z Rail II, Durodyne, or equal.
34. Fabricate round supply connections at rectangular, plenum type fittings using spin-in type fittings, complete with extractor and volume control damper. Refer to Paragraph "DAMPERS" for damper requirements.
35. Provide drive slip or equivalent flat seams for ducts exposed in the conditioned space or where necessary due to space limitations. On ducts with flat seams, provide standard reinforcing on inside of duct. Duct connection to outlet on exposed duct shall be full size of outer perimeter of outlet flange.
36. Ducts exposed in the conditioned space shall be free of dents and blemishes and be mounted tight against adjacent surface with flat hangers. Remove all fabrication labels from ductwork.
37. Provide 20 gauge minimum for ductwork exposed within occupied spaces.

J. Rectangular Internally insulated Duct:

1. Provide internal duct lining where indicated on the Drawings, with a minimum of 10'-0" length in each direction from the fan, fan casing, or unit casing. Line all transfer ducts.
 - a. Where ductwork is exposed to weather or outside the building insulation envelope, provide 2 inch thick, 1-1/2 pound density internal lining with matte facing, with an R-Value of 8.0 minimum.
 - b. Where ductwork is within the building insulation envelope, lining shall be 1" thick, 1-1/2 pound density, with R-value of 4.2 minimum.

- c. Ducts exposed in the conditioned space shall be free of dents and blemishes and be mounted tight against adjacent surface with flat hangers. Remove all fabrication labels from ductwork.
- d. Where installed exposed in the conditioned space, duct shall be minimum 20 gauge with 1 inch insulation layer (minimum R-value – R-4.2).
- e. Cement duct liner in place with nonflammable, non-hardening duct adhesive. Seal all raw edges of insulation inside ductwork with adhesive, including longitudinal liner edges.
- f. Provide metal nosing at all locations where liner is preceded by unlined metal.
- g. Provide sheet metal weld pins and washers or clinch pins and washers on all ductwork on 12 inch intervals with the first row within 3 inches of the leading edge of each piece of insulation and within 4 inches of corners. No use of adhesive mounted pins will be considered.
 - 1) Install clinched pin fasteners with properly adjusted automatic fastening equipment. Manual installation will not be considered.
 - 2) Install weld pins with properly adjusted automatic fastening equipment. Installation shall not damage the galvanized coating on the outside of the duct.
- h. All ductwork, adhesives, lining, sealant, flex duct and the like shall have a flame spread of 25 or less and developed smoke rating of 50 or less when tested in accordance with one of the following test methods: NFPA 255, ASTM E84, or UL 723.
- i. Manufacturers: Subject to compliance with requirements, available manufacturers offering products that may be incorporated into the Work include the following, or equal:

j.	Manufacturer:	k.	Product:
l.	Johns Manville	m.	Duct Li PM
n.	CertainTeed Corporation	o.	ToughG
p.	Fosters Adhesive	q.	85-62
r.	Swifts Adhesive	s.	7336

K. Round and Oval Ductwork Fabrication:

1. Round and oval duct and fittings shall be spiral lockseam or longitudinal seam as indicated in table below. Provide couplings to join each length of duct.
 - a. At contractors' option, round or oval ductwork may be utilized in place of rectangular ductwork shown on Drawings, provided available space allows installation of round or oval ductwork without compromising space required for installation of products and systems of other trades.
 - 1) Round or oval ductwork utilized in place of rectangular ductwork shown on Drawings shall be sized to have a static pressure loss equivalent to rectangular duct shown on Drawings.
 - 2) Unlined round or oval duct shall not be utilized in place of rectangular internally lined ductwork shown on Drawings.
2. Fabricate duct fittings to match adjoining ducts and to comply with duct requirements as applicable to fittings. Except as otherwise indicated, fabricate elbows with center-line radius equal to 1.5 times associated duct width. Provide two-piece, die-stamped, 45-degree to 90-degree elbows for sizes up to 12 inches; five-piece, 90-degree elbows for sizes 12 inches and above; conical tees; and conical laterals. All reducers shall be placed after a tap has been made on the duct main. Reducers shall be long-taper style.
3. Round Ductwork: Construct of galvanized sheet steel complying with ANSI/ASTM A 653 by the following methods and in minimum gauges listed.

4.	Diameter	5.	Minimum Gauge	6.
7.	Up to 14"	8.	26	9.
10.	15" to 23"	11.	24	12.
13.	24" to 36"	14.	22	15.
16.	37" to 50"	17.	20	18.
19.	51" to 60"	20.	18	21.
22.	Over 60"	23.	14	24.

25. Provide locked seams for spiral duct; fusion welded butt seam for longitudinal seam duct.
26. Fittings and Couplings: Construct of minimum gauges listed. Provide continuous welds along seams at exposed ducts. Provide spot weld bonded seams at concealed ducts.

27.	Diameter	28.	Minimum Gauge
29.	3" to 36"	30.	20
31.	38" to 50"	32.	18
33.	Over 50"	34.	16

35. Ducts exposed in the conditioned space shall be free of dents and blemishes and be mounted tight against adjacent surface with flat hangers. Remove all fabrication labels from ductwork.

36. Provide 20 gauge minimum for ductwork exposed within occupied spaces.

L. Round Internally Insulated Duct and Fittings: Where ductwork is exposed to weather or outside the building insulation envelope, construct with outer pressure shell, 2 inch thick (Minimum R-value = R-8) insulation layer, and perforated inner liner. Where ductwork is within the building insulation envelope, construct with outer pressure shell, 1 inch thick (minimum R-value = R4.2) insulation layer, and perforated inner liner. Construct shell and liner of galvanized sheet steel complying with ANSI/ASTM A 653, of spiral lockseam construction (use longitudinal seam for over 59 inches), in minimum gauges listed in table below. Where installed exposed in the conditioned space: duct and fitting outer pressure shell shall be minimum 20 gauge with 1 inch insulation layer (minimum R-value = R-4.2).

M.	Nominal Duct Diameter	N.	Outer Shell	O.	Inner Liner
P.	3" TO 12"	Q.	26 gauge	R.	24 gauge
S.	13" TO 24"	T.	24 gauge	U.	24 gauge
V.	25" to 34"	W.	22 gauge	X.	24 gauge
Y.	35" to 48"	Z.	20 gauge	AA.	24 gauge
BB.	49" to 58"	CC.	18 gauge	DD.	24 gauge

EE.	Over 59"	FF.	16 gaug e	GG.	20 gaug e
-----	-------------	-----	-----------------	-----	-----------------

1. Fittings and Couplings: Construct of minimum gauges listed. Provide continuous weld along seams of outer shell at exposed ducts. Provide spot weld bonded seams at concealed ducts.

2.	Nominal Duct Diamet er	3.	Outer Shell	4.	Inner Liner
5.	3" to 34"	6.	20 gaug e	7.	24 gaug e
8.	36" to 48"	9.	18 gaug e	10.	24 gaug e
11.	Over 48"	12.	16 gaug e	13.	24 gaug e
14. Inner Liner: Perforate with 3/32 inch holes for 22 percent open area. Provide metal spacers welded in position to maintain spacing and concentricity.
15. Ducts exposed in the conditioned space shall be free of dents and blemishes and be mounted tight against adjacent surface with flat hangers. Remove all fabrication labels from ductwork.
16. Where installed exposed in the conditioned space, duct shall be minimum 20 gauge with 1 inch insulation layer (minimum R-value – R-4.2).
17. All ductwork, adhesives, lining, sealant, flex duct and the like shall have a flame spread of 25 or less and developed smoke rating of 50 or less when tested in accordance with one of the following test methods: NFPA 255, ASTM E84, or UL 723.
18. Optional Ducts and Fittings: At Installer's option, provided that certified tests by manufacturer show that rigidity and performance is equivalent to SMACNA and/or ASHRAE standard gauge ductwork, provide ducts and fittings as follows:
 - a. Ducts: Construct of manufacturer's standard gauge, with spiral lock seam and intermediate standing rib.
19. Manufacturers: Subject to compliance with requirements, available manufacturers offering products that may be incorporated into the Work include the following, or equal:
 - a. Sheet Metal Div., McGill AirFlow, LLC., Acousti-k27

- b. Semco Duct and Acoustical Products, Inc.
- c. Air Systems Manufacturing, Inc. - Las Vegas

HH. Duct Access Doors:

1. Duct Access: Provide hinged access door in rectangular ducts for access to fire dampers, control equipment, etc. Access door size shall be duct diameter wide by duct diameter high for all ducts under 24 inches. Ducts over 24 inches in diameter shall have 24-inch by 18-inch access doors. Minimum size access doors shall be 6 inches by 6 inches.
2. Provide hinged style access doors for round ductwork, NCA Manufacturing, Inc., Model AD-RD-87, Pottorff Series 60, or equal. Access doors shall be 16 gauge galvanized steel with continuous piano hinge. Locks shall be plated steel strike and catch. Provide 1" x 3/8" Polyethylene "Perma Stik" gasket all around door.
3. Duct Access Panels:
 - a. Provide duct access panel assembly of the same material and gauge used for the duct. Duct access panels shall conform to the following:
 - 1) Fasteners: Black steel or stainless steel to match material used for the duct. Panel fasteners shall not penetrate duct wall.
 - 2) Gasket: Comply with NFPA 96, grease-tight, high temperature ceramic fiber, rated for minimum 1500 °F.

II. Fume hood exhaust ductwork: Provide 304 Stainless steel, all welded joints for fittings, 22 gauge minimum, except 20 gauge minimum where exposed to weather. Prefabricated United McGill Corp. Low Pressure Spiral stainless steel duct and fittings, Semco Manufacturing, or equal, may be used. Assemble with acid-resistant duct sealant and stainless steel screws.

JJ. Provide Ventlon, or equal, flexible connections on inlet and outlet of AC Unit, air handler and exhaust fans. Provide galvanized weather hood over flexible connections exposed to the weather.

2.08 TEMPERATURE CONTROL SYSTEM

- A. Refer to drawings for additional details and information.
- B. Provide control system to match district standards.
- C. All conduit and wiring associated with the temperature control system, regardless of voltage, is included as part of this Section. Contractor shall obtain power for temperature control devices from the nearest available adequate source. Furnish all interlocks, power supplies, relays, and the like required to render the control system complete and functional for the intended use.
- D. Control contractor shall add to the existing host software all program functions required to implement the sequence of operation on the Drawings.

- E. Provide outside air dampers and return air dampers to allow setting of minimum outside air. Provide dampers to close outside air duct when unit is cycled off. Counterbalanced dampers shall be used at each location.

PART 3 - EXECUTION

3.01 ROOF MOUNTED EQUIPMENT

- A. Mount and anchor equipment in strict compliance with drawings details. Alternate anchorage methods will not be considered for roof mounted equipment.
- B. Examine rough-in for roof mounted equipment to verify actual locations of piping and duct connections prior to final equipment installation.
- C. Verify that piping to be installed adjacent to roof mounted equipment allows service and maintenance.
- D. Verify that gas piping will be installed with sufficient clearance for burner removal and service.
- E. Install ducts to termination at top of roof curb and install heavy duty rubber gaskets on supply and return openings and on full perimeter of curb, or as required for an airtight installation, prior to setting unit on curb.
- F. Cover roof inside roof mounted air conditioning unit with 2" thick, 3 pound density fiberglass insulating board.
- G. Connect supply and return air ducts to horizontal discharge roof mounted equipment with flexible duct connectors specified elsewhere in these Specifications.
- H. Remove roof decking only as required for passage of ducts. Do not cut out decking under entire roof curb.

3.02 INSTALLATION OF FANS

- A. Ceiling Mounted Fans: Mount variable speed switch within fan housing. Mark final balance point on variable speed switch.
- B. Provide access doors for fans or motors mounted in ductwork.
- C. Mount all fans as detailed on Drawings and in compliance with CBC standards.
- D. Fan motors mounted in air-stream to be totally enclosed.
- E. Completely line supply, return or exhaust fan cabinets with 1 inch thick, 3/4 pound density acoustic insulation securely cemented in place.
- F. Roof fans shall be mounted level.
- G. Provide heavy-duty rubber gasket between exhaust fan mounting flange and roof curb, or as required for an airtight installation.

- H. Label fume hood fans with sign "CAUTION - HAZARDOUS EXHAUST".

3.03 RELIEF VENTS

- A. Install relief vents to provide a level mounting for backdraft damper.

3.04 AIR INLETS AND OUTLETS

- A. Provide all air inlets and outlets with gaskets and install so that there will be no streaking of the walls or ceilings due to leakage. Duct connection to outlet on exposed duct shall be full size of outer perimeter of outlet flange.
- B. Unless otherwise indicated on Drawings, provide rectangular plenum on top of each diffuser and ceiling return for connection to ductwork. Line plenum with internal insulation as indicated for lined ductwork. Size plenum to allow full opening into air terminal.
- C. Ceiling-mounted air terminals or services installed in T-Bar type ceiling systems shall be positively attached to the ceiling suspension main runners or to cross runners with the same carrying capacity as the main runners.
 - 1. Terminals or services weighing not more than 56 pounds shall have two No. 12 gauge hangers connected from the terminal or service to the structure above. These wires may be slack.
 - 2. Support terminals or services weighing more than 56 pounds directly from the structure above by approved hangers. Provide 4 taut 12 gauge wires each, attached to the fixture and to the structure above. The 4 taut 12 gauge wires, including their attachment to the structure above must be capable of supporting 4 times the weight of the unit.
 - 3. Secure air inlets and outlets to main runners of ceiling suspension system with two #8 sheet metal screws at opposing corners.
- D. Furnish all air inlets and outlets with a baked prime coat unless otherwise noted. Provide off-white baked enamel finish on ceiling-mounted air inlets and outlets. Paint exposed mounting screws to match the material being secured.
- E. Air inlets and outlets shall match all qualities of these specified including appearance, throw, noise level, adjustability, etc.

3.05 DAMPERS

- A. All dampers automatically controlled by damper motors are specified under "Temperature Control System" except those specified with items of equipment.
- B. Provide opposed blade manual air dampers at each branch duct connection and at locations indicated on the drawings and where necessary to control air flow for balancing system. Provide an opposed blade balancing damper in each zone supply duct. Provide an access panel or Ventlok flush type damper regulator on ceiling or wall for each concealed damper.
- C. Install fusible link fire dampers full size of duct at points where shown or required.

- D. Provide 18 inch x 12 inch minimum hinged access doors in ductwork and furring for easy access to each fire damper; insulated access doors in insulated ducts. Label access doors with 1/2 inch high red letters.
 - 1. Provide Ventlok Series 100, Durodyne, or equal access doors with hardware for convenient access to all automatic dampers and other components of the system, insulated type in insulated ducts. Provide Ventlok #202 for light duty up to 2 inch thick doors, #260 heavy-duty up to 2 inch thick doors and #310 heavy-duty for greater than 2 inch thick doors. Provide #260 hinges on all hinged and personnel access doors; include gasketing.

3.06 INSTALLATION OF DUCTWORK

- A. Assemble and install ductwork in accordance with recognized industry practices which will achieve air tight and noiseless (no objectionable noise) systems capable of performing each indicated service. Install each run with minimum of joints. Align ductwork accurately at connections within 1/8 inch misalignment tolerance and with internal surfaces smooth. Support ducts rigidly with suitable ties, braces, hangers, and anchors of type which will hold ducts true to shape and to prevent buckling. Where possible, install ductwork to clear construction by 1/4 inch minimum, except at air inlets and outlets. Where ductwork will not clear construction, secure duct firmly to eliminate noise in the system.
- B. Duct Joints: Install duct sealers, pop rivets or sheet metal screws at each fitting and joint. Duct sealer shall be fire retardant. Sheet metal screw for joints shall be minimum #10 size galvanized.

C. Applicable Leakage Classes:

D.	Pressure Class	E.	Leakage Class		
F.		G.	Round Duct	H.	Rectangular Duct
I.	2"W.G. or less	J.	12	K.	12
L.	4"W.G. or greater	M.	3	N.	6

- O. Upper connection of support to wood structure shall be with wood screws or lag screws in shear fastened in the upper one half of the wood structural member. Fasteners shall conform to the following schedule:

P.	For ducts with P/2=30"	Q.	#10 x 1-1/2" wood screw
R.	For ducts with P/2=72"	S.	1/4"x 1-1/2" lag screw
T.	For ducts with P/2	U.	3/8"x 1-1/2"

over 73"

lag screw

- V. Upper connection in tension to wood shall not be used unless absolutely necessary. Where deemed necessary the contractor shall submit calculations to show the size fastener and penetration required to support loads in tension from wood in accordance with the following schedule:

W.	For ducts with P/2=30"	X.	260 pounds per hanger
Y.	For ducts with P/2=72"	Z.	320 pounds per hanger
AA.	For ducts with P/2=96"	BB.	460 pounds per hanger
CC.	For duct with P/2 larger than 120"	DD.	NOT ALLOWED

- EE. Upper connection to manufactured truss construction must comply with truss manufacturers published requirements and Structural Engineers requirements.
- FF. Where ducts pass through interior partitions and exterior walls, conceal space between construction opening and duct or duct plus insulation with sheet metal flanges of same gauge as duct. Overlap opening on four sides by at least 1-1/2 inches.
- GG. Support ductwork in manner complying with SMACNA "HVAC Duct Construction Standards," hangers and supports sections. Where special hanging of ductwork is detailed or shown on Drawings, Drawings shall be followed. Angles shall be attached to overhead construction in a manner so as to allow a minimum of 2 inches of movement in all directions with no bending or sagging of the angle.
1. Except where modified in individual paragraphs of this Section, provide hanger support with minimum 18 gauge straps, 1 inch wide. Fold duct strap over at bottom of duct.
 2. Install duct supports to rectangular ducts with sheet metal screws. Provide one screw at top of duct and one screw into strap at bottom of duct.

3.07 DUCTWORK SEALING AND LEAK TESTING

- A. Retrofit Construction, including alterations to existing duct system or space conditioning equipment: All duct systems (supply, return, outside air intake and exhaust), except those exposed in the conditioned space, shall be sealed and leak tested in strict conformance with the requirements of section 149 of the 2008 California Building Energy Efficiency Standards. See drawings for extent of this work and leakage rate requirements. The leakage rate shall be confirmed through field verification and diagnostic testing in accordance with the procedures set forth in the 2008 California Building Energy Efficiency Standards Non-Residential ACM Manual. Contractor shall also complete the Acceptance Requirements in the standards for duct sealing/leak testing. Refer to Section 23 00 50 for further information on Acceptance Requirements.

3.08 TEMPERATURE CONTROL SYSTEM

- A. Provide thermostats and control switches where indicated on drawings. All wiring shall be in conduit. Provide all relays, transformers and the like to render the control system complete and fully operable. All control conduit to be rigid steel type.

3.09 TESTING AND BALANCING

- A. Obtain the service of an independent test and balance agency that specializes in, and whose business is limited to, testing and balancing of air conditioning systems. Balance agency shall be a member of Associated Air Balance Council (AABC). Coordinate testing and balancing agency work with work of other trades.
- B. Testing and balancing agency, as a part of its contract, shall act as authorized inspection agency and shall report any discrepancies or items not installed in accordance with Contract Drawings and/or Specifications pertaining to air and water distribution, and exhaust systems.
 - 1. Balance report shall be signed by the Contractor, attesting that all reported deficiencies have been corrected. Balance reports containing uncorrected deficiencies will be rejected.
- C. Provide for adjustments and/or additions or modifications to fan and motor sheaves, belts, damper linkages and the like to achieve proper air balance at no additional cost.
- D. Perform testing and balancing in complete accordance with AABC National Standards. Perform testing on the following:
 - 1. Air distribution system
- E. Instruments used for testing and balancing of systems shall have been calibrated within a period of six (6) months and shall be checked for accuracy prior to start of work.
- F. Submit three (3) copies of complete test report prior to final acceptance of project.
- G. Tabulate magnetic starters size, type, and manufacturer with heater strip size, type and rating along with motor nameplate data.
- H. Measure the ampere reading of each motor input after final adjustments have been made.
- I. Air Distribution System Balancing:
 - 1. Balance air quantities of supply, return, outside air, and exhaust to achieve those given on Drawings with accuracy within minus 5 percent and plus 10 percent. Measure the total air quantity at each fan. Measure the total air quantity at each supply fan with maximum outside air and with minimum outside air. Measure the ampere reading of each motor input after final adjustments have been made. Upon satisfactory completion of balance and operational test, submit three sets of reports to the Architect on balance final readings, summary of fan CFM delivery rates, static pressure ratings, motor ampere input, and general summary of test results. Specified ratings and motor nameplate ratings shall be listed with measured readings.

- a. Check and report operation of relief air dampers. Ensure that dampers remain full open during economizer cycle, and full closed at all other times. Measure and report total relief from power economizer operation during each phase of economizer cycle.
 - b. Test each system for building operating pressure, under all operating conditions, including all phases of the economy cycle. Maximum building pressure shall not exceed 0.03 inches of pressure.
 2. Balance air quantities of supply to achieve those given on drawings. Keep records on all air quantities measured, including tests prior to final balance. Use branch duct volume control dampers for balancing. Use of terminal dampers is not acceptable.
 - a. Provide listing of supply, return, and exhaust outlets and inlets by room number, and provide key plan identifying outlet and inlet locations. Where multiple outlets and inlets are installed within a room, a designation shall be assigned and listed for each outlet and inlet in addition to room number. Listing and key plan outlet and inlet identification shall correspond to identification used in air balance report.
 3. Air balance shall be achieved using variable fan speeds.
 4. Adjust single or double deflection registers and variable pattern diffusers to evenly distribute air within the conditioned space. The terminal air velocity at 5 feet above the floor shall not exceed 50 FPM in normal air conditioned spaces.
 5. Test economizer cycle for each air system.
 - a. Adjust control systems to provide correct operation.
 - b. Adjust relief air dampers as required to provide 100 percent relief in economizer mode, and confirm satisfactory operation of all backdraft dampers.
 - c. Provide, as part of air balance report, final settings of each economizer control, and total air flow through relief air hood.
- J. Special Requirements: Fume Hood Air Flow Measurement Procedures shall be used to tabulate performance data for the fume hoods and fans.
1. Fume Hood Air Flow Measurement Procedures:
 - a. Rooms under study cleared of all but study personnel.
 - b. All doors in rooms under study closed securely (unless otherwise indicated on fume exhaust hood data sheets) to simulate most adverse conditions.
 - c. Power supply to all fans operating the fume hoods in rooms under study activated.
 - d. All fume hood sashes positioned wide open.

- e. Airflow data obtained by holding test instrument flush with and in plane of the hood sash.
- f. With survey personnel standing well clear of the measurement area, nine, evenly spaced measurements per laboratory type fume exhaust hood shall be recorded in a three by three grid as indicated below.

g.		j.	1	
h.		n.	4	
i.	full op en	q.	7	

3.10 EQUIPMENT START-UP

- A. Initial start-up of the systems and pumps shall be under the direct supervision of the Contractor.
- B. Equipment start-up shall not be performed until the piping systems have been flushed and treated and the initial water flow balance has been completed.
- C. It shall be the responsibility of the Contractor to assemble and supervise a start-up team consisting of Controls Contractor, Start-Up Technician and Test and Balance Contractor; all to work in concert to assure that the systems are started, balanced and operate in accordance with the design.
- D. After start-up is complete, instruct the Owner's personnel in the operation and maintenance of the systems. Obtain from the Owner's representative a signed memo certifying that instruction has been received.

3.11 ANTI-VIBRATION BASES AND HANGERS

- A. Isolate all ventilating and air conditioning equipment connections including conduit, piping, drains, etc., so that equipment will operate under continuous demand without objectionable vibration.
- B. Support all air conditioning units, all fans, and all pumps of 5 HP and over on anti-vibration bases or hangers. Other equipment shall be supported on anti-vibration bases, pads, or hangers, as shown on the drawings or specified with the equipment. Individual fans shall have integral fan and motor bases, spring-type unless noted. High velocity fans - unguided stable springs with 2" deflection.
- C. Selection of the bases or supporting units shall be in accordance with the vibration eliminator manufacturer's recommendations. Minimum static deflection shall be 1-1/2 inches or as marked on the drawings.
- D. The equipment manufacturer shall furnish the weight of equipment at each point of support.

3.12 CLEANING AND PROTECTION

- A. Clean ductwork internally, unit by unit as it is installed, of dust and debris. Clean external surfaces of foreign substances that might cause corrosive deterioration of metal or where ductwork is to be painted.
- B. Strip protective paper from stainless ductwork surfaces, and repair finish wherever it has been damaged.
- C. Temporary Closure: At ends of ducts that are not connected to equipment or air distribution devices at time of ductwork installation, provide temporary closure of polyethylene film or other covering that will prevent entrance of dust and debris until connections are to be completed.
- D. At completion of work, check internal lining for small cuts, tears, or abrasions. Repair all damage with fire retardant adhesive.

3.13 ACCEPTANCE REQUIREMENTS

- A. In addition to the testing and balancing requirements specified in the previous section, the contractor shall also be responsible to complete all the Acceptance Requirements of the 2008 California Building Energy Efficiency Standards. Refer to Section 23 00 50 for further information on Acceptance Requirements.

3.14 EQUIPMENT MOUNTING

- A. Mount and anchor equipment in strict compliance with drawings details. Alternate anchorage methods will not be considered for roof mounted equipment.

[END OF SECTION 23 80 00]

**SECTION 26 00 00
ELECTRICAL GENERAL REQUIREMENTS**

PART 1 - GENERAL

1.01 WORK INCLUDED

- A. Furnish and install all necessary labor, materials, tools and equipment to perform and completely finish the work according to the intent of this specification, and the accompanying drawings.
- B. Furnish and install any incidental work which can reasonably be inferred as required and necessary to provide complete and workable systems.
- C. Provide connections of all equipment specified under these sections and other Divisions including Divisions 22 (Plumbing) and 23 (HVAC) including installation and connection of all motors, relays, remote starters, etc.
- D. The requirements of the General and Supplemental Conditions, and Division 01 apply to Divisions 26, 27 and 28, and these specifications. All sections in Divisions 26, 27, and 28 are interrelated. Work specified in other sections, as applicable, shall apply to all work hereunder.

1.02 LOCAL CONDITIONS

- A. Examine site; verify dimensions and locations against drawings and become informed of all conditions under which work is to be done before submitting proposal. No allowance will be made for extra expenses because of omission on Contractor's part to include cost of work under prevailing conditions.
- B. Information shown relative to services is based upon available records and data shall be regarded as approximate only. Minor deviations found necessary to conform with actual locations and conditions shall be made without extra cost.
- C. Extreme care shall be exercised in excavating near existing utilities to avoid any damage thereto. It shall be the contractor's responsibility to verify existing underground utilities prior to digging anywhere. Information provided on these plans indicating existing conditions shall only be used as reference, and shall not be deemed considered accurate. Any damage to existing utilities done by the contractor shall be repaired and/or replaced by the contractor at their expense to its pre-damage condition.

1.03 PERMITS AND INSPECTIONS

- A. Obtain and pay for all permits and service charges required in installation of the work. Arrange for required inspections and secure approvals from authorities having jurisdiction.
- B. During its progress, work shall be subject to inspection by Project Inspector.

1.04 CODES AND STANDARDS

- A. Work and materials shall be in full accordance with California Occupational Safety Health Act (CAL-OSHA), California Electrical Code (CEC), State Fire Marshal, Electrical Safety Orders (Title 8, Subchapter 5), the National Fire Protection Association, California Building Code (CBC); California Code of Regulations - Title 24 and other applicable State or local laws or regulations. Nothing in the

Drawings or Specifications shall be construed to permit work not conforming to these codes.

- B. Electrical materials shall bear the label of, or be listed by, the Underwriter's Laboratories (UL) unless of a type for which label or listing service is not provided.
- C. Materials and components shall conform to Industry Standards, including:
 - NEMA - National Electrical Manufacturer's Association
 - ANSI - American National Standards Institute
 - ASTM - American Society For Testing Material Association
 - IPCEA - Insulated Power Cable Engineer's Association
 - CBM - Certified Ballast Manufacturers
- D. When Contract Documents differ from governing codes, furnish and install larger size or higher standards called for without extra charge.

1.05 REVIEW OF MATERIALS

- A. Prior to commencement of Work and within 35 days after award of contract, submit for approval in accordance with General Conditions all equipment and materials to be furnished.
 - 1. Equipment/Product submittals shall be bound and indexed and shall include a table of contents listing all equipment submitted. The table of contents shall include: Project designation, submittal number, submittal name including specification section, date, and include manufacturer, model number, reference specification paragraph or sheet detail number, description, and page location. Where a group or series of products are submitted, each item do not have to be listed, only the series need to be identified. Example:

Project:
Submittal No.
Submittal Name:
Date:

<u>Page(s)</u>	<u>Manufacturer</u>	<u>Model No.</u>	<u>Detail No.</u>	<u>Spec para., Description</u>
1-12	XYZ Corp	123ABC	2.5	Control panel
13,14	XYZ Corp	456DEF	2.6-A	Power supply
15	ABC Corp	789GHK	A/E9.5	Rack
16,17	Cantex	PVC-40	2.1	PVC conduit
18	Steel City	XYZ series	2.2	Steel fittings

- 2. Shop drawings submittals shall be neat and professionally done using CAD (computer aided drafting), hand-drawn submittals will not be accepted. Shop drawings shall have sufficient information to clearly indicate work to be performed and be complete including device/equipment locations, wire sizes, wire types and number of wires, symbol list or legend, point-to-point connections, wiring diagrams, and equipment anchorage detail where needed. Shop drawings shall utilize the same size paper as the Bid set of plans.
- B. Substitutions:
 - 1. Only one request for substitution will be considered on each item of material or equipment. No substitutions will be considered thereafter. Substitutions will be interpreted to be all manufacturers other than those specifically listed by model or catalog number. Should the

original submittal of a proposed substitution be rejected, the specified item shall be furnished.

2. Submit complete information or catalog data to show equality of equipment or material offered to that specified. Identify which product is being substituted in the specifications and/or the plans and provide analysis as indicating either it "Complies" or that it "Does Not Comply" and providing a reason. Each Specification paragraph shall be provided with this analysis. No substitutions will be allowed unless requested and approved in writing. Materials of equal merit and appearance, in the opinion of the Engineer, will be approved for use. Engineer reserves the right to require originally specified item.
 3. Acceptance of a substitute is not to be considered a release from the Specifications. Any deficiencies in an item, even though approved, shall be corrected by the Contractor at his expense.
 4. Responsibility for installation of approved substitution is included herein. Any changes required for installation of approved substituted equipment shall be made without additional cost to Owner.
- C. Where it is in the best interest of the Owner, Engineer may give written consent to a submittal received after expiration of designated time limits, or for an additional resubmittal.
- D. Submit for approval in ample time to avoid delay of construction, shop drawings or submittals on all items of equipment and materials covered in list mentioned above. Submit in accordance with General Conditions in a complete package; partial submittals will not be considered.
- E. Failure to comply with any of the preceding requirements will necessitate that the specified materials be submitted and supplied.

1.06 RECORD DRAWINGS

- A. Upon completion of Work, furnish Engineer with AutoCAD file, PDF file, and one printed full size hardcopy upon which shall be shown all Work installed under contract including any Work which are not in accordance with Original Contract Drawings. AutoCAD files shall be 2004 or later version, with external references bound to its parent drawing. Provide a separate PDF file for each sheet, do not combine all sheets into a single file. Furnish digital files on a USB flash drive or CD.
1. The above shall also include shop drawings.
- B. All symbols and designations used in preparing Record Drawing shall match those used in Contract Drawings.
- C. Show all buried and concealed conduit, stub-outs, etc. Locate all buried conduit and stub-outs by dimensions from permanent, easily located and identifiable portions of structure; also, dimension ends of stub-outs, etc. Note depth of buried items below grade.

1.07 ADDENDA AND CHANGE ORDERS

- A. Changes in the plans and specifications shall be made by Addenda or Change Orders signed by the Engineer.

PART 2 - PRODUCTS

2.01 MATERIALS

- A. Materials mentioned herein or on drawings require that each item listed be provided and of quality noted, or an approved equal. All material shall be new, full weight and standard in all respects and in first-class conditions. Where possible, all materials used shall be of the same brand or manufacturer throughout for each class of material or equipment.
- B. Grade or quality of materials desired is indicated by trade names or catalog numbers stated herein. Dimensions, sizes and capacities shown are a minimum and shall not be changed without permission of Engineer.

PART 3 - EXECUTION

3.01 DRAWINGS AND COORDINATION

- A. Examine Drawings and Site; be familiar with types of construction where electrical installation is involved. Work shall be neatly installed in a workmanlike manner in accordance with NECA Standard of Installation. Work shall be coordinated with other trades to avoid conflicts. Clarifications will be made by Engineer and minor adjustments shall be made without additional cost to Owner. Obtain ruling from Engineer concerning any obvious discrepancies or omissions in work before bidding. All work involved in correcting obvious errors or omissions after award of Contract shall be performed as directed by Engineer without additional cost to Owner.
- B. Layouts of equipment, accessories and wiring systems are diagrammatic (not pictorial), but shall be followed as closely as possible. Drawings and Specifications are for assistance and guidance, and exact locations, distances, levels, etc., will be governed by Site.
- C. All equipment (devices, conduits, boxes, etc.) shall be flush or semi-flush mounted unless otherwise noted. Where conditions do not allow flush mounting and where acceptable to the Architect, equipment may be surface mounted.

3.02 WORKING SPACE

- A. Provide adequate working space around electrical equipment in compliance with Article 4 of Electrical Safety Orders. In general, provide 36 inches minimum clear work space in front of panelboards and controls of 120/208 volt systems and 42 inches minimum for 277/480 volt systems.

3.03 CARE AND CLEANING

- A. All broken, damaged or otherwise defective parts shall be repaired or replaced without additional cost to Owner. Work shall be left in a condition satisfactory to Engineer. At completion, carefully clean and adjust all equipment, fixtures and trim installed as part of this work. Systems and equipment shall be left in a satisfactory operating condition.
- B. All surplus materials and debris resulting from this work shall be cleaned out and removed from site; this includes surplus excavated material.

3.04 PROTECTION

- A. In performance of work, protect work from damage. Protect electrical equipment, stored and installed, from dust, water or other damage.

3.05 EQUIPMENT IDENTIFICATION

- A. Panelboards, remote control switches, terminal boxes, etc., shall be properly identified with a descriptive nameplate. Nameplate shall be made of 3/32 inch laminated plastic with black background and white letters. Size of letters shall be 1/4 inch high for equipment in device box or boxes 12" or smaller, and 1/2 inch high for panelboard, terminal can, or larger items. Letters shall be machine engraved. Punched strip type nameplates and cardholders in any form are not acceptable. Nameplates shall be attached with oval head machine screws tapped into front panel.
- B. Indicate type of equipment and equipment designation, ex. "PANEL-XXX", "MAIN SWITCHBOARD-XXX", "TRANSFORMER-XXX", "SIGNAL-XXX", "TV-XXX", "EF-1", "AC-1", etc.

3.06 RUST INHIBITOR

- A. Channels, joiners, hangers, straps, clamps, brackets, caps, nuts and bolts and associated parts shall be plated electrolytically with zinc followed immediately thereafter by treating freshly deposited zinc surfaces with chromic acid to obtain a surface which will not form a white deposit on surface for an average of one hundred twenty (120) hours when subjected to a standard salt spray cabinet test, or shall be hot dipped galvanized.

3.07 TEST

- A. Test all wiring and connections for continuity and grounds; where such test indicate faulty insulation or other defects, locate, repair and retest. Balance loads at panelboards. Furnish all testing equipment.

3.08 CLOSING OF AN UNINSPECTED WORK

- A. Do not allow or cause any of work installed hereunder to be covered up or enclosed before it has been inspected and approved.
- B. Should any work be enclosed or covered up before it has been approved, uncover such work and after it has been inspected and approved, make all repairs necessary to restore work of others to conditions in which it was found at time of cutting, all without additional cost to Owner.

3.09 WARRANTY

- A. All materials and installation shall be provided with a one (1) year warranty which shall include replacement parts, labor, retesting, and travel to and from the job site. The warranty period shall begin after final acceptance of the project. The warranty shall cover but is not limited to the following:
 - 1. Defective workmanship and installation.
 - 2. All System components, devices, conduit, wires, etc.
 - 3. Manufactured items such as light fixtures, receptacles, switchboard, panelboard, transformer, switches, etc.
 - 4. Basic materials such as conduit, wires, boxes, cabinets, etc.

- B. Certain manufactured items will have longer warranty periods. Refer to specific item and specification section for warranty information and terms.

END OF SECTION

**SECTION 26 05 00
BASIC MATERIALS AND METHODS**

PART 1 - GENERAL

1.01 SCOPE

- A. The work of this Section consists of basic materials and methods for all work included under Divisions 26, 27, and 28. Additional specifications requirements for electrical work are specified under other sections of Divisions 26, 27 and 28 and where those requirements differ from the requirements of this Section, they shall govern.

1.02 SUBMITTALS

- A. Submit product data per Section 26 00 00.

PART 2 - PRODUCTS

2.01 CONDUIT

- A. Rigid Steel Conduit: Standard weight, mild steel pipe, zinc coated on both inside and outside by a hot dipping or sherardizing process. Inside and outside of conduit shall be finished with a protective coating. All threads galvanized after cutting. Meets UL 6, UL Card #DYIX, and ANSI C80.1.
- B. Intermediate Metallic Conduit (IMC): Intermediate weight, mild steel pipe, meeting same requirements for finish and material as rigid steel conduit. Meets UL 1242, UL Card #DYIX, and ANSI C80.6.
- C. Electrical Metallic Tubing (EMT): Cold rolled steel tubing, hot-dipped galvanized, with zinc coating on outside and protective lubricating coating on inside. Fittings shall meet same requirements for finish and material as EMT. Meets UL 797 and ANSI C80.3.
- D. Flexible Conduit: UL Listed. Flexible steel, zinc coated on both inside and outside by hot dipping or sherardizing process. Liquid-tight conduit shall be galvanized with extruded polyvinyl covering and with watertight connectors, sunlight resistant, direct burial rated. Flexible steel conduit less than 1/2" shall not be used except that 3/8" shall be permitted in lengths not in excess of 6 feet as part of a listed assembly or for tap connections to lighting fixtures as required in CEC Section 410-67(c). Flexible conduit to be one continuous length, no couplings. AFC Liquid-Tuff Type-LFMC and AFC Reduced Wall Flexible Steel Conduit or equal.
- E. Raceway Fittings:
 - 1. Rigid Steel Conduit: Fittings, such as couplings, connectors, condulets, elbows, bends, etc., shall be subject to same requirements as for rigid steel conduit. Couplings and unions shall be threaded type, assembled with anti-corrosion, conductive anti-seize compound at joints made absolutely tight to exclude water. Connectors shall be threaded hubs with bonding insulated metallic bushings. Unions shall be equal to Crouse Hinds UNY or UNF.
 - 2. IMC: Fittings shall be as specified for rigid steel conduit.
 - 3. EMT: Fittings shall be steel, box connectors shall have insulated throat. Connectors and couplings to be compression type.

4. Flexible Metallic Conduit: Connectors to be insulated. Metallic connectors (except for liquid-tight) shall be steel "squeeze" type via a screw, Steel City XC-90X and XC-49X series. Liquid-tight metallic connectors shall be watertight approved for such use.
 5. Bushings: Metallic insulated type. Weatherproof or dust-tight installations; liquid-tight with sealing ring and insulated throat, OZ/Gedney type "KR".
 6. Expansion and Deflection Fittings: OZ/Gedney, Type "DX" or accepted equal.
 7. All box connectors to be insulated throat type.
 8. Conduit Straps: Galvanized steel, 2-hole straps. 1-hole straps may be used for conduit sizes 1" and smaller concealed in wall or above ceiling.
 9. PVC Conduit: Fittings shall be same grade of material as conduit, solvent welded to conduit.
- F. Metallic conduits, raceways, and fittings shall be listed and approved as a grounding means.

2.02 BOXES

- A. Galvanized one-piece or welded pressed steel type. Boxes for fixture shall not be less than 4" square and shall be equipped with fixture stud. Boxes shall be at least 1-1/2" deep, 4" square for 1 or 2 gang devices, with plaster rings and gang box with gang cover. Boxes mounted in wall or ceiling finished with gypsum board shall be furnished with 3/4" deep plaster rings. Use screws and not nails to support/secure outlet boxes. Provide blank cover plates for all boxes without devices.
1. 1-gang and 2-gang outlet and junction boxes installed exposed outdoors shall be weatherproof type FS, FD, WS, WD die cast metal or aluminum boxes, Appleton or equal. Plug all unused hubs.
 2. Provide 1#12 equipment grounding pigtail at all outlet boxes.
 3. Outlet boxes for data, telecommunications, video, and TV outlets shall be 4 11/16" square x 2.125" deep.
 4. Outlet boxes containing #8, #6, or #4 AWG wires shall be a minimum 2.125" deep per CEC.
- B. Junction boxes located outdoors, or in wet or damp locations shall be rated NEMA-3R, with hinged door and pad-locking tabs.
- C. Equipment furnished by other trade but require electrical connection shall be provided with appropriate backbox.

2.03 WIRES

- A. Wire shall be copper only, manufactured by General Cable Co., Rome, General Electric Co., or Anaconda. Wire shall be rated 90 degrees C for both dry and wet locations, THWN-2, XHHW-2, or RHW-2 insulation. 90 degrees C THHN may be used in dry and damp locations. Wire installed in high temperature areas, including branch circuits in or above roof insulation or in fluorescent ballast channel, shall have type RHW-2 or XHHW-2 90° insulation.

1. Feeders sized #2 and larger routed below grade, extending beyond or outside the building foundation line shall use types XHHW-2, THW-2, or RHW-2 insulation, 90 degrees C dry and wet rated.
- B. Wire shall be Code type copper wire of not less than 98% conductivity. Wires #8 gauge and larger, shall be stranded. Wires shall bear the Underwriters' label, be color coded and be marked with gauge, type and manufacturer's name on 24" centers. Wires smaller than #8 may be solid or stranded. Where stranded wire is used, provide solid pigtail for connection to screw terminals of receptacles, switches, etc.
- C. Color coding to be as follows:

	<u>208/120 Volts</u>	<u>480/277 Volts</u>
Phase A	Black	Brown
Phase B	Red	Orange
Phase C	Blue	Yellow
Neutral	White	Natural Grey
Ground	Green	Green

Switch legs shall use the same branch circuit phase color coding which they are connected to. IG ground wire shall be green with yellow tracer.

- D. Bring wire to job in original unbroken packages. Obtain approval of inspector or Engineer before installation of wires.

2.04 WALL SWITCHES

- A. Shall be "AC" rated, heavy duty, quiet type, rated 20 amperes at 277 volts A.C. Application of switches shall comply with CEC Section 380-8. Handles shall be bakelite; color shall be compatible with adjacent wall finish. Switches to be as follows:

<u>Manufacturer</u>	<u>Single Pole</u>	<u>3-Way</u>
A & H	1991	1993
Hubbell	1221	1223
P & S	20AC1	20AC3
Leviton	1221	1223

- B. Weatherproof light switches shall have lever switch covers of die cast construction with gasket and gray finish. Hinged flip-lids are not acceptable.

2.05 CONVENIENCE OUTLETS

- A. Shall be "Specification" grade rated 15 amperes at 125 volts, duplex, composition base with slots to accommodate parallel plug caps with grounding peg. Contact shall grip both sides of plug prongs. Where only one receptacle is connected to a 20 ampere circuit, a 20 ampere receptacle shall be used. Outlet shall be UL listed. Receptacles to be Hubbell or equal.

1. 15 Amp: Hubbell 5262 series Heavy Duty Industrial Grade, 8200 series for Hospital Grade.
2. 20 Amp: Hubbell 5362 series Heavy Duty Industrial Grade, 8300 series for Hospital Grade.
3. Other designations as noted below:

- a. Ground Fault: GFR
 - b. Tamper Resistant: TR
 - c. Weather Resistant: WR
 - d. Isolated Ground: IG
- 4. Leviton 5252, 5352, 8200, and 8300 series can be considered equal.
- 5. Pass & Seymour 5252, 5352, 8200, 8300 series can be considered equal.
- B. Provide devices with matching plates. Isolated ground (IG) receptacles shall be orange with matching color plate. Hospital grade receptacles shall have a distinctive "green" dot. GFI receptacles shall have a visible (light) indicator.
- C. All 15 and 20 Amp, 125V and 250V non-locking receptacles (NEMA 5-15, 5-20, 6-15, 6-20) located outdoors and/or in damp or wet locations shall be listed weather-resistant type. Weather resistant receptacles shall be the same grade or class as 15A and 20A receptacles specified above.
- D. Weatherproof covers for receptacles in wet locations shall be rated as weatherproof whether or not a plug is inserted (NEMA-3R), minimum 3.25" clearance from front of receptacle, metallic cast type with hinged lid and padlocking hasp, Leviton or equal. Weatherproof covers for receptacles in damp locations shall be rated as weatherproof when attachment plug is removed, with metallic cast cover and flip lids with padlocking hasp.
- E. Provide a separate GFI duplex receptacle at each location identified on the drawings and as specified. Through wiring is not acceptable. Receptacles located at the following locations shall be GFI type, whether indicated in the plans or not.
 - 1. In elevator control rooms.
 - 2. In elevator pits/shafts.
 - 3. In bathrooms or restrooms.
 - 4. Outdoors, on the exterior of the building, and on/above the roof.
 - 5. In commercial and institutional kitchens, unless dedicated to specific equipment.
 - 6. Within 72" from any sink or basin such as in a small kitchen, lunch/break room, and the like.

2.06 SAFETY/DISCONNECT SWITCHES

- A. Type "HD" Heavy Duty safety switches with externally operated handle. Switches shall be manufactured by Westinghouse, General Electric, Square D, or approved equal. Switches shall be rated 250 and 600 volts, A.C., of size and poles as shown on Drawings and as required. Disconnects used outdoor shall be in NEMA-3R. Provide fused switches with proper sized fuses where required by equipment manufacturer. All switches shall have pad-locking cover with interlocking cover. Switches shall be capable of be pad-lockable in the ON or OFF position. Label switch with circuit identification per section 26 00 00, example "AC-1, HD1-24".

2.07 INDIVIDUAL CIRCUIT BREAKERS

- A. Circuit breakers shall be molded case thermal magnetic type with trip rating as scheduled on drawings.
 - 1. Circuit breaker trip settings 300 amps and higher shall be solid state type with field adjustable Long-Time and Instantaneous settings and field replaceable trip rating plugs.

2. Circuit breakers with trip settings 1200 amps and higher shall be solid state electronic type with full function trip units including: LTUP, LTD, STPU, STD, Inst PU, Inst OFF, GFPU, GFD.
- B. Circuit breakers shall be quick-make, quick-break, trip free operation. The trip-free mechanism shall be independent of manual handle control. All circuit breakers shall be fully rated to withstand the available short circuit current as designated on the drawings. Series rated equipment will not be acceptable.
 - C. Breakers to be in NEMA-1 (indoor) or NEMA-3R (damp, wet, and outdoor) enclosures. NEMA-3R enclosures shall have the handle concealed behind the cover, and the hinged cover shall be provided with padlocking tabs. Each circuit breaker shall be identified with an engraved, laminated phenolic plate showing the load served or the function of the circuit breaker and trip rating. The nameplate shall be attached with oval head machine screws tapped into the front of the board. Equip breaker handles with padlocking "lock-off" devices.
- 2.08 PULL LINE
- A. Furnish and install pull line in all unused (empty) raceways. Pull lines shall not rot or mildew.
 1. Conduits up to 1.5": 1/8" diameter braided line of polypropylene with 200 lbs. tensile strength, IDEAL, Jet-Line #232 or equal.
 2. Conduits 2" or larger: 3/16" polypropylene pull rope with 800 lbs. tensile strength, IDEAL Pro-Pull or equal.
 - B. Provide pull line in conduits for utility company systems, size and type per their requirements.
- 2.09 ACCESS DOORS
- A. Milcor, Newman or equal with concealed hinges, screwdriver locks, prime coated with rust inhibitive paint, and style of door to suit ceiling or wall construction, including fire rating. Access doors in acoustical tile ceilings shall be Hi-Hatch with tile recess. Doors shall be 14 gage C.R. steel and shall be 22" x 30"; 24" x 24" in tile ceilings, unless otherwise noted or required.
- 2.10 BACKBOARDS
- A. Backboards shall be 3/4" plywood, type A-C grade fire treated for interior use, and type Exterior Grade for outdoor use. Backboards located outdoors shall be provided with one coat primer and two coats of exterior paint. Backboards in terminal cabinets shall be same as for interior use.
- 2.11 TERMINAL CABINETS
- A. Terminal, relay, and contactor cabinets shall be code gauge, size as indicated with appropriate trim for mounting as indicated, with hinged door and cylinder type locks. NEMA-1 for indoor use in dry areas and NEMA-3R for outdoor use or in wet locations. Surface mounted cabinets shall not have knockouts. Provide backing plate/board for mounting equipment. Circle A-W or equal.
 - B. Provide engraved plastic label per section 26 00 00. Label shall identify the type of cabinet and designation, example "FIRE ALARM - FCA" and "EXTERIOR LIGHTING - RA".

2.12 SURFACE METALLIC AND NONMETALLIC RACEWAYS

- A. The surface raceway system for branch circuit wiring and/or data network, voice, video and other low-voltage wiring shall be manufactured by the Wiremold Company, or equal. Raceway series as indicated on the plans. The raceway and all system components must be UL listed and exhibit non-flammable self-extinguishing characteristics. The raceway shall be a two-piece design with a base and a snap-on cover.
 - 1. The nonmetallic raceway base and cover shall be manufactured of rigid PVC compound, available in ivory color. Exposed cuts shall be covered with cover clips.
 - 2. The metal raceway base and cover shall be manufactured of galvanized steel, ivory finish and suitable for field painting.
- B. A full compliment of fittings must be available including, but not limited to flat, internal and external elbows, tees, entrance fittings, boxes, covers, adapters, cover clips, and end caps. The fittings shall match the base and cover, and be of matching colors. All fittings shall be supplied with a base where applicable to eliminate mitering. A transition fitting shall be available to adapt to other Wiremold series raceways. Field cuts shall be clean, straight, and true with no rough edges.
- C. For multicompartment raceways, device brackets shall be available for mounting standard devices in-line or offset from the raceway. A device bracket shall be available for mounting up to four devices at one location. Faceplates shall match and fit flush in the device plate and shall overlay the cover and base to hide uneven cuts. They shall match the raceway base and cover. The raceway manufacturer will provide a complete line of connectivity outlets and modular inserts for UTP (i.e. data jacks), STP (150 ohm), Fiber Optic, Coaxial and other cabling types with face plates and bezels to facilitate mounting.
- D. Work shall include furnishing all raceway and appropriate fittings and device plates to install a nonmetallic surface raceway system. Installer shall comply with detailed manufacturer's instruction sheets, which accompany system components as well as system instruction sheets.

2.13 COVER PLATES

- A. Switch and receptacle cover plates shall be smooth nylon type. Cover plates for other devices/outlets such as data, telephone, television, etc. shall be nylon. Cover plate color shall be ivory, matching all systems.
- B. For multi-purpose rooms, gymnasiums, kitchens, locker rooms, toilet/restrooms, and walls such as CMU, brick, concrete block, and concrete walls, device plates shall be smooth stainless steel with beveled edges.
- C. Each receptacle shall have its circuit identification on the cover plate (i.e., "LA1-12"). Use typewritten "clear tape". Use black letters/numbers. Clean surface before adhesive tape is applied, and wrap tape around each end to prevent peeling.
 - 1. For floor boxes, plates shall be engraved with circuit identification.

PART 3 - EXECUTION

3.01 CONDUITS

- A. All conduits shall be rigid steel or IMC except EMT may be used at following locations:
1. In dry locations in concealed furred spaces.
 2. In partitions other than concrete, concrete block, or solid masonry.
 3. For exposed work indoors and outdoors above 10 ft except:
 - a. In special locations prohibited by Code, such as hazardous locations, rigid steel shall be used.
 - b. Conduits exposed on/above the roof shall be rigid steel up to 10 ft above roof surface.
 - c. Conduits exposed in Gymnasiums and Multi-Purpose Rooms shall be rigid steel up to 25 ft.
 4. Concealed above suspended ceilings or ceilings directly attached to structure above.
- B. Flexible conduit shall be used to provide flexible connections of short length (3 ft or less) to equipment subject to vibration or movement and to all motors. Up to 6 ft is allowed where additional flexibility is needed. Provide a separate bonding conductor in all flexible connections/conduit. Flexible conduit shall be one continuous length without couplings.
- C. Run conduit concealed in areas having finished ceilings and in walls. Run all cross conduits and vertical risers or drops concealed in wall and/or partitions. Should it be necessary to notch any framing members, make such notching only at locations and in a manner as approved by the Architects. Where concealing conduit is not possible or practical, conduit may be run exposed in areas only where so permitted by the Architect. Install exposed conduit run neatly, parallel to or at right angles to structural members. Maintain a minimum of 6" clearance from steam or hot water pipes.
- D. Support conduit with straps and secure to wood structure by means of bolts or lag screws, to concrete by means of insert or expansion bolts, to brickwork by means of expansion bolts, and to hollow masonry by means of toggle bolts. Expanders and shields shall be steel or malleable iron.
- E. Support individual conduits with 2-hole steel straps. 1-hole steel straps may be used for conduits 1" and smaller concealed in wall or above ceilings.
- F. Galvanized iron hanger rods sizes 1/4" diameter and larger with spring steel fasteners, clips or clamps specifically designed for purpose for conduits up to 1" size may be used.
- G. Individual conduits 3/4" and smaller run above wire suspended ceilings may be supported from independent hanger wires with approved spring steel clips. Wire ties will not be acceptable. Wire shall be taut and secured to ceiling and structure above.
- H. Support multi-parallel horizontal conduit runs with trapeze type hangers consisting of two or more steel hanger rods, cross channels, J-bolts, clamps, etc.
- I. Sizes of rods and cross channels shall be designed to support four times actual load. Hanger rods shall have safety factor of 5 based on ultimate strength of material used.

- J. Conduits for data, telecommunications, signal, video, TV, and/or containing fiber optic, coaxial, or OSP (outside plant) multi-pair cables shall have a minimum inside bend radius per CEC Table 346-10 (do not use exception); except that conduits 2" to 4" shall be minimum 24" radius bends.
- K. After installation of conductors, all conduits routed below grade shall be sealed at each opening, including risers and in pull boxes, to prevent the entrance of water and debris.
- L. Conduits not terminated into a box or cabinet, such as stubbed to a backboard, shall be terminated with an insulated bushing. Bushings for metallic conduits shall be metallic type secured by set screw, compression, or threaded type. Bushings for PVC conduits shall be glued in place.
- M. Although circuiting is shown as diagrammatic, their point-to-point destinations and their indication of above/below ground route shall be followed as much as possible. Where site conditions dictate that an alternate means of routing will alleviate conflicts, the alternate means will be considered with prior approval by the Engineer.
- N. Where cinder fill is encountered in Block walls, conduit shall be PVC-40 where in contact with cinder fill. Boxes shall be PVC type where in contact with cinder fill.
- O. EMT conduit circuits installed on the roof, if allowed by the Engineer, shall have a ground conductor routed with the circuit conductors sized per the circuit protective device.
- P. Horizontal runs of conduit above suspended wire lay-in ceilings shall not be less than 12" above the ceiling.
- Q. Maintain 12 inch separation between power circuits (>120V) and all signal circuits (data, telephone, speaker, clock, etc.) to prevent interference.
- R. Feeder conduits connected to panels/switchboard shall have ground lug bushing connected to equipment ground buss with ground wire same size as largest ground wire in the panel/switchboard.
- S. Conduits penetrating through the roof shall be secured within 12" below roof and supported within 12" of the penetration on the roof.
- T. Where conduits cross building expansion/seismic joints provide a short length of flexible conduit (do not exceed 6 ft.) and fittings listed as a grounding means, or in locations where flex conduit cannot be used provide UL listed expansion/seismic fittings.
- U. Conduits concealed in any masonry shall be routed in a conduit sleeve. Such sleeves shall not be placed closer than 3 diameters, center to center.
- V. Conduits to air conditioning (AC) equipment, fans, or other roof mounted equipment shall rise up from the ceiling below through the equipment curb or conduit window within the equipment, if allowed by equipment manufacturer, to prevent additional roof penetrations.
- W. Where conduit passes through finished walls or ceilings, provide steel escutcheon plates, chrome or painted as directed. Conduit which penetrate floor slabs, concrete or masonry walls shall be grouted and sealed watertight at penetrations.
- X. For 20-amp 120 or 277 Volt circuits:
 - 1. Do not install more than six(6) circuits in any conduit.

2. Do not install more than seven(7) current carrying conductors in any conduit.
3. Where using #10 AWG wires to allow for conductor derating.
4. Do not install more than twelve(12) circuits in any conduit.
5. Do not install more than twelve(12) current carrying conductors in any conduit.

Y. Cables and Raceways installed under metal-corrugated sheet roof decking shall maintain a minimum 1.5" from the nearest surface of the roof decking per CEC. This shall not apply to RMC or IMC.

3.02 CAPPING

- A. Cap conduits during construction with manufactured seals. Swab out conduits before wires are pulled in.
- B. Cap all empty conduits below grade and in pull boxes with manufacturer's caps to prevent entrance of water and debris, attach pull string to cap.

3.03 FLASHING

- A. Make conduit projecting through roof watertight by proper flashing. Secure a sheet lead cap with a tightening bend to conduit. Use two collars for tar or asphalt composition roofings. Set one collar directly on roof deck and second collar set over on top of roofing felts. Lead sheet flashing shall be made of 4 lb. sheet lead.

3.04 PENETRATIONS OF FIRE RESISTIVE WALLS AND PARTITIONS

- A. Penetrations of protected openings (fire rated walls, ceilings, floor-ceilings, roofs, etc.) shall be protected in accordance with the California Building Code, Part 2, Chapter 7, Title 24. Penetrations shall apply to conduits (raceways), cable trays, boxes, cabinets, panels, cables, etc.
- B. Fire stopping shall be provided at penetrations of fire resistive walls, floors, ceilings, floor-ceiling assemblies, and roofs. Fire-stopping shall have a "F" and/or "T" rating as determined by tests conducted in accordance with ASTM E 814 or UL-1479. Fire stopping system/materials shall be UL Listed.

3.05 ACCESS DOORS

- A. Furnish and install access doors wherever required whether shown or not for easy maintenance of electrical systems; for example, inaccessible areas and attics containing heat detectors, junction boxes, etc. Access doors shall provide for complete removal and replacement of equipment. Provide fire rated access doors where located in fire rated partitions.

3.06 BOXES

- A. Nails shall not be used to support outlet boxes. Boxes must be accurately placed for finish, independently and securely supported by adequate wood backing or by manufactured adjustable channel type heavy-duty box hangers. For metal stud construction, use metal box hangers only. Box hangers shall be securely tied or welded (where permitted) or screwed to metal studs. Paint weld with rust inhibitor. Boxes installed in masonry tile or concrete block construction shall be secured with auxiliary plates, bars or clips and be grouted in place.

1. Outlet Boxes with Receptacles or Switches: Provide a solid pigtail (green) ground wire

grounded to the metallic outlet box. Pigtail shall also ground device and separate ground conductor if available. Size of ground wire to match overcurrent protection.

- B. Locate outlets at the following heights above floor to the center of the device or handle unless otherwise noted on Drawings or in Specifications.
 - 1. The top of the outlet box shall not be higher than 48" above finished floor, and the bottom of the outlet box shall not be less than 15" above finished floor. For forward or side approach over counter, maximum 44" and 46" respectively to top of box.
 - 2. Convenience Outlets: 18" (4" above counter or splash).
 - 3. Local Switches: 45".
 - 4. Telephone Outlets: 18" (45" for wall phone).
 - 5. Data, TV Outlets: 18".
 - 6. Where devices are shown at counter locations, they shall be located approximately 4" above counter, clearing back-splash where applicable.
 - 7. Refer to elevations and details on Architectural Drawings for exact heights and locations of all electrical outlets for switches, receptacles, special equipment, etc. Where above heights do not suit building construction or finish, consult Architect.
- C. Install pull boxes or junction boxes as required in accessible spaces but do not install in finished areas unless approved by Architect.
- D. Where fire rated construction is required (refer to Architectural Drawings), do not locate electrical outlet boxes back-to-back. Provide a minimum of 24" horizontal separation between outlet boxes on opposite side of the same wall. Where such restrictions cannot be met, provide fire-stopping around box such as 3M Moldable Putty Pads or equal.
- E. Boxes up to 100 cubic inches located in suspended wire ceilings may be supported through an independent hanger wire with approved tension clips. Wire shall be taut. Secure wire to the structure above and the ceiling below.

3.07 CONDUCTORS

- A. Splices and joints for #10 AWG or smaller wiring shall be twisted together electrically and mechanically strong and insulated with approved type insulated electrical spring connectors, Scotchlok or Ideal. Joints and connections for #8 AWG or larger shall be made with Burndy, T & B, or approved equal, solderless tool applied pressure lugs and connectors. Uninsulated lugs and wire ends shall be insulated with layers of plastic tape equal to insulation of wire and with all irregular surfaces properly padded with "Scotchfil" putty prior to application of tape. Tape shall be equal to Scotch #33, General Electric #AW-1, or approved equal. Feeder splicing is not permitted.
 - 1. In special instances where feeder splicing is allowed by the Engineer, it shall be made with high compression sleeve type connector followed by manufactured splicing kit utilizing as insulators, resins poured into a ready-to-use plastic mold to provide a uniform, moisture-proof tough, impact-resistant insulation.

2. Conductor splices below grade shall meet ANSI C119.1-1986 and UL 486D Standards. Raychem WCSM or FCSM heavy wall heat shrink tubing; or RVS or RVC series if use of flame heat is prohibited. Conductors to be joined with compression sleeve connectors.
- B. Use only UL approved wire pulling compound as lubricant.
 - C. Lace conductors together with waxed linen lacing cord, T & B "Ty-Rap", Holub "Quik-Wrap" or equal, in a neat and workmanlike manner in panelboards, wireways, raceways, pull boxes and similar locations.
 - D. #12 AWG wire shall be minimum size wire used for lighting and power circuits. Motor control circuits may be #14 except as marked on Drawings, unless shown.
 - E. Provide cable supports in risers by means of a clamping device with insulated wedges or "Kellem" grips.
 - F. All conductors shall be in conduit unless otherwise indicated.
 - G. Conduit sizes shall be based on code fill table for THW insulated wires to accommodate the number, size, and type of wires shown or specified.
 - H. Wiring installed in pull boxes or junction boxes, where wire is pulled through without terminations (except splices), shall have a service loop around the interior of the box for 360 degrees utilizing the largest circumference.
 - I. Use #10 AWG conductor for 20 Amp 120 Volt circuit home runs longer than 75 feet, and for 20 Amp 277 Volt circuit homeruns longer than 200 feet.
 - J. Where conductors are increased in size and number (such as for voltage drop reasons), such that conductors will not fit the standard breaker or panel lugs, terminate conductors in one of the following means:
 1. Provide larger breaker frame or panelboard.
 2. Provide oversized lugs.
 3. Last option only with approval from Engineer: Terminate wires in multiport connector and provide pigtail. Splice to be made in panel or switchboard if space is available, or in separate splice box. This option will not be normally granted.

3.08 PANELS AND CABINETS

- A. Recessed enclosures (panelboards, terminal cabinets, cabinets, control cabinets, etc.) shall be provided with a minimum of three 3/4" empty conduits stubbed into accessible space above the ceiling. Drawings may require additional conduits.

3.09 GROUNDING

- A. Grounding and ground bonding of the electrical installation shall be in accordance with CEC Article 250, and any applicable codes. Ground fittings shall be approved manufactured type, installed and connected to conform with Code requirements.

- B. Neutral conductors and noncurrent-carrying parts of equipment at each installation shall be grounded in accordance with applicable code. Ground conductor shall be copper having a current capacity sized in accordance with CEC.
- C. All equipment cases, motor frames, etc., shall be completely grounded to satisfy requirements of CEC. Install bond wire in flexible conduit. Install copper bond wire, sized in accordance with CEC, in all nonmetallic raceways and bond to all metallic parts using approved fittings.
- D. Interior metallic cold water pipe system and other interior metallic piping systems shall be ground bonded to the building grounding system.
- E. Each building shall be provided with a grounding electrode connected to the metallic enclosure of the building disconnecting means. Grounding electrode conductor shall be sized per CEC table 250-66.
- F. Total ground resistance shall not exceed 25 ohms.
- G. All connections shall be made with solderless connectors or molded fusion-welding process.
- H. Equipment grounding conductors shall be insulated with a continuous green outer finish along its entire length. Conductors size #4 AWG and larger may be identified (with green electrical tape applied half-lapped) at each end and at every point where the conductor is accessible. Tape shall be applied from its point of entry to point of exit or termination.
- I. Insulated grounded (neutral) conductors shall be identified with a continuous white outer finish along its entire length. Neutral conductors #4 AWG or larger can be identified by a distinctive white marking (applied half-lapped with white electrical tape) for the last 12 inches at each end.

3.10 FIELD TESTS

- A. General: Perform field test in the presence of the Owner's Representative except as otherwise specified. Provide required labor, materials, equipment and connections to perform tests. Document results and submit them to the Owner's Representative. Repair or replace all defective work.
- B. Perform Insulation Resistance (IR) "Megger" Testing per NETA Standards. Submit test results. Provide testing for:
 - 1. All feeders 100 Amps and higher.
 - 2. Branch circuits 100 Amps and higher.
- C. Verify operation of starters and install overload protection devices sized in accordance with the motor full load current.
- D. Summarized the results of the power system study in a bound final report. Organize the report using the following sections:
 - 1. Description, purpose, basis, written scope, and a single-line diagram of the portion of the power system which is included within the scope of study.
 - 2. Protective device time versus current coordination curves, tabulations of relay and circuit breaker trip settings, fuse selection, and commentary regarding same.

3. Provide a separate tabulated list for the selection and settings of the protective devices. Include the following minimum information:

- a. Circuit identification.
- b. IEEE device number.(Where applicable)
- c. Manufacturer, device type and range of adjustment.
- d. Recommended settings.

3.11 GROUND FAULT PROTECTION AND TESTING

- A. Where indicated on the plans, provide circuit breaker with ground fault protection. The ground fault system shall include a memory circuit for positive tripping action despite intermittent arcing ground faults.
- B. Provide an integral means of testing the ground fault system to meet the on-site requirements of CEC Articles 230 and 517.
- C. Provide acceptance testing per InterNational Electrical Testing Association Inc. (NETA) specifications and standards. Submit test results.

3.12 CLEANING

- A. Brush and clean work prior to concealing, painting and acceptance. Performed in stages if directed.
- B. Clean and repair soiled or damaged painted exposed work and match adjoining work before final acceptance.
- C. Remove debris from inside and outside of material, equipment and structures.

3.13 WARRANTY

- A. All materials and installation shall be provided with a one (1) year warranty which shall include replacement parts, labor, retesting, and travel to and from the job site. The warranty period shall begin after final acceptance of the project.

END OF SECTION

**SECTION 26 50 00
LIGHTING**

PART 1 - GENERAL

1.01 SECTION INCLUDES

- A. Furnish and install a complete lighting system consisting of incandescent and fluorescent luminaires, lamps, ballasts, automatic wall switches, occupancy sensors, and appurtenances as shown on drawings and specified.

1.02 WORK INCLUDED

- A. The requirements of Sections 26 00 00 and 26 05 00 shall apply to the Work of this Section.

1.03 QUALITY ASSURANCE

- A. All materials shall comply with applicable standards of the Underwriter's Laboratories, Inc.

1.04 SUBMITTALS

- A. Manufacturer's product data and materials. Include technical specification information, photometric data, fixture efficiency, ballasts information, lamp information, weights, accessories, etc. In addition for occupancy sensors, submit performance specifications, coverage patterns, and load restrictions.
- B. Submit a occupancy sensor shop drawings identifying device location and orientation for occupancy sensors, automatic wall switches, and associated equipment. Indicate sensor sensitivity and time delay adjustment.
- C. Submit per Section 26 00 00.
- D. As-builts drawings, product information, and O&M Manuals shall be furnished upon completion of the project.

PART 2 - PRODUCTS

2.01 BALLASTS

- A. Electronic Fluorescent Ballasts (T8 lamps):
 - 1. Lamp Frequency: >40 kHz.
 - 2. 120/277 Dual Voltage or Single Voltage.
 - 3. Starting Method: Instant Start.
 - 4. Circuit Type: Parallel
 - 5. High Power Factor: >98%.
 - 6. Crest Factor (CCF): Less than 1.7.
 - 7. Low THD: <10%.
 - 8. Normal Ballast Factor (NBF) of 0.88, Low Ballast Factor (LBF) of 0.78. All ballasts shall have Normal Ballast Factor unless otherwise noted on the plans.
 - 9. Ballasts shall operate lamps with no visible flicker (<5% flicker index).
 - 10. UL Listed Class P, Type 1 Outdoor, CSA Certified, 70 deg-C maximum case temperature, 75 deg-C maximum case temp (4-lamp model), FCC 47CFR Part 18 Non-Consumer,

- Class-A Sound Rating, ANSI C62.41 Cat. A Transient Protection.
11. Minimum Starting Temperature: 50°F (indoor), 0°F (outdoor).
 12. Manufacturers: OSRAM Sylvania, G.E., Motorola or equal.
 13. Based on F32T8 lamps with initial lamp lumens of 2850, ballast and lamp performance shall be as follows. A 2.5% tolerance is acceptable.

<u>No. of Lamps</u>	<u>Ballast Factor</u>	<u>System Lumens</u>	<u>Watts</u>	<u>System Eff(lum/w)</u>
1-F32T8	0.78	2220	26	86
2-F32T8	0.78	4445	48	93
3-F32T8	0.78	6670	71	94
4-F32T8	0.78	8890	92	97
1-F32T8	0.88	2510	28	90
2-F32T8	0.88	5015	55	91
3-F32T8	0.88	7520	81	93
4-F32T8	0.88	10030	105	96

2.02 LAMPS

- A. Provide lamps, of wattage and type as shown on the drawings, for all fixtures. Lamps shall be OSRAM Sylvania, G.E., or Philips.
- B. Fluorescent Lamps:

<u>Lamp</u>	<u>Initial Lumens</u>	<u>Min CRI</u>	<u>Rated Life</u>
F13CFL:	900	82	12k
F18CFL:	1250	82	12k
F26CFL:	1800	82	12k
F32CFL:	2400	82	12k
F42CFL:	3200	82	12k
F32T8:	2850	78	24k
F25T8:	2150	78	24k
F17T8:	1325	78	24k

1. Unless otherwise indicated on the drawings, color temperature (CCT) to be 3500K.
2. Fluorescent lamps shall pass the U.S. Federal EPA Toxicity Characteristic Leaching Procedure (TCLP) and shall have green lamp etches or green component materials used in the lamp for identification as TCLP compliant.

2.03 LUMINAIRES

- A. Luminaires recessed in ceiling shall conform with UL Standards. Equip fluorescent luminaire with fixture yoke to prevent tees from spreading where applicable and install field fabricated fire protection box (open ends) constructed of 1-5/8" thick UL listed gypsum board.
- B. Weatherproof fixtures shall have neoprene gaskets on fixture trim and door assemblies. Fixture shall be UL listed for wet locations.
- C. Luminaire voltage indicated on the plans is for reference. Verify actual voltage required based on the branch circuit.

- D. Housing shall be prefinished. Color to be selected by Engineer.
- E. Verify fixture mounting to ceiling type. Fixture shall be compatible with the ceiling type.
- F. Recessed and Surface Troffers:
 - 1. Lens shall be 0.125" minimum thickness, virgin acrylic, clear prismatic K-12.
 - 2. Fixture housing, trim, door frame, hinges, latches, etc. shall be metal, no plastic parts except for gaskets and sockets.
 - 3. Housing and door shall be 20 gauge steel, paint-after-fabrication.
 - 4. Specification grade quality.
 - 5. Fully enclosed spring loaded cam latches, smooth operation.
 - 6. Five stage phosphate bonding process with baked white enamel finish.
 - 7. Approximately 4.375" deep (lensed), 5.75" deep (parabolic).
 - 8. For lensed fixtures, the center of the lamp to the top of the lens shall be minimum 2.875" +/- 10%.

2.04 EMERGENCY FIXTURES/BALLASTS

- A. Emergency ballasts in fluorescent troffers shall be rated at 1100 lumens for 90 minutes, solid state, with NiCad batteries rated at 15 yrs., charger, automatic operation, UL listed. It shall be located in the ballast channel of the fixture. With test switch and indicator lights visible from below. Emergi-Lite FPS series, Bodine or equal.
- B. Emergency ballasts for compact fluorescent downlight fixtures shall be integral with the fixture, UL listed, 90 minutes rated light output, NiCad batteries, charger, solid state, with test switch and indicator light visible from below. Initial lumen output to be: 13W to 26W CFL = 700 lumens, above 26W CFL to be 1100 lumens. Bodine B84CG or equal.
- C. Emergency fixtures shall be UL listed, 12Vdc, metal housing, NiCad batteries rated 15 yrs., wattage rating at 1.5 hrs (minimum 36 Watts), automatic charger, 100% solid state, indicator lights, test switch, capable of remote operation. Emergi-Lite 12JS series or equal. Where heads are to be provided, provide two 9 Watt HIT heads metal.
- D. The emergency ballast in a fixture that is used for egress lighting and energized only during an emergency shall not have thermal protection.
- E. Remote exterior dual heads shall be weatherproof, gasketed aluminum housing with two 9 Watt HIT heads.

2.05 OCCUPANCY SENSORS & AUTOMATIC WALL SWITCHES

- A. Products to be Watt Stopper or equal.

1. Automatic Wall Switches, PIR: WS-200 single level switching. #WA-300 with hard lens for dual level switching, with manual-ON or auto-ON for each output relay.
 2. Ceiling Sensors, Ultrasonic: W-500A or WT-605 (500 sf), W-1000A or WT-1105 (1000 sf), W-2000A or WT-2205 (2000 sf), W-2000H or WT-2255 (10x90 linear ft).
 3. Dual Technology: DT-200.
 4. PIR Sensors: CX-105 (wall), CI-205 (ceiling).
 5. Power/Switch Packs: As required for proper system operation.
 6. Provide with relays and light level sensor where needed proper for system operation.
- B. Wall Switches: Shall be capable of desktop detection of 300 sf and gross motion of 1000 sf; loads from 0 to 800 watts at 120 Volts, 0 to 1200 Watts at 277 Volts; 180 degrees coverage; zero crossing circuitry; no leakage current to load; selectable for auto-ON or manual-ON for each output relay/circuit.
- C. PIR Sensors: Utilize Pulse Count Processing and Digital Signature Analysis; mixed signal ASIC from false triggering to RFI and EMI interference; multiple segmented Lodif fresnel lens in multi-layer configuration with internal grooves.
- D. Ultrasonic Sensors: Utilize advanced signal processing to adjust detection threshold dynamically to compensate for constantly changing levels of activity and air flow in the space; crystal controlled at 25 kHz, 32 kHz, or 40 kHz with maximum +/-0.005% tolerance for reliable performance and to eliminate sensor cross talk.
- E. Dual Technology: Shall utilize PIR and ultrasonic technologies. Both technologies to switch ON, either technologies to remain ON.
- F. All Sensors: Shall have readily accessible user adjustable settings for time delay and sensitivity; bypass manual override in event of failure; LED visual indication of detected motion; UL rated.

2.06 WIRING

- A. Fixtures shall be wired with conductors having insulation suitable for the environmental conditions, current, voltage, and temperature to which the conductors are subjected.
- B. 120/208 Volt Luminaire: 300 Volt, type AF, HFF, KFF, SFF, ZFF, or equal, beginning at separately mounted outlet box.
- C. 277/480 Volt Luminaire: 600 Volt, type HFF, KFF, PFF, ZF, ZFF, or equal, beginning at separately mounted outlet box.

2.07 DISCONNECTING MEANS

- A. Indoor fluorescent light fixtures utilizing double-ended lamps and containing ballasts or having ballasts shall be provided with an internal or external disconnecting means to disconnect all supply conductors to the ballast including the grounded conductor if any. Disconnecting means shall meet 2010 CEC 410.130(G).

PART 3 - EXECUTION

3.01 INSTALLATION

- A. Refer to reflected ceiling drawings; coordinate therewith for ceiling fixture installations throughout building. Luminaires shall be adequately mounted, wired, tested and left in an operating condition, complete with lamps, wattage as shown.
- B. All dirt, plaster, paint, etc., on luminaires and lenses shall be removed before work will be accepted. Mounting of luminaires shall be in strict accordance the CEC Section 410.
- C. Report changes in outlet locations of luminaires found necessary due to interference with structure, pipes, ducts, etc., to Architect for approval before installation. Luminaires specified with overall lengths are subject to change. Check job conditions; adjust as directed.
- D. Lighting System Acceptance Testing: Provide acceptance testing in accordance with Title-24 California Energy Commission Building Energy Efficiency Standards. After system installation, provide FACTORY COMMISSIONING by the manufacturer's factory authorized technician to verify proper system adjustments, systems settings, systems testing, sensor placements, and train owner's personnel for adjustment and maintenance. Submit Certificate Of Acceptance. Testing shall include (subject to systems installed):
 - 1. Occupancy Sensors.
 - 2. Manual Daylighting Controls.
 - 3. Automatic Daylighting Controls.
 - 4. Automatic Time Switch Controls.

3.02 WARRANTY

- A. All materials and installation shall be provided with a one (1) year warranty which shall include replacement parts, labor, retesting, and travel to and from the job site. The warranty period shall begin after final acceptance of the project.
 - 1. Occupancy sensors & automatic wall switches to have a 5 year warranty.

END OF SECTION

**SECTION 27 05 00
COMMON WORK RESULTS FOR COMMUNICATIONS**

PART 1 - GENERAL

1.01 SUMMARY

- A. Section includes, but is not necessarily limited to:
1. Common standards and procedures for the Communications Work.
 2. Design, engineer and provide complete, all means of support, suspension, attachment, fastening, bracing, and restraint (hereinafter "support") of the Work of this Division. Provide engineering of such support by parties licensed to perform work of this type in the Project jurisdiction.
- B. Provisions of this Section apply to Communications Work, including the following Sections:
1. Section 27 05 26 – Grounding and Bonding for Communications Systems
 2. Section 27 05 29 – Hangers and Supports for Communications Systems
 3. Section 27 05 33 – Conduits and Backboxes for Communications Systems
 4. Section 27 05 36 – Cable Trays for Communications Systems
 5. Section 27 05 39 – Surface Raceway for Communications Systems
 6. Section 27 05 43 – Underground Ducts and Raceways for Communications Systems
 7. Section 27 05 48 – Noise and Vibration Controls for Communications Systems
 8. Section 27 05 53 – Identification for Communications Systems
 9. Section 27 10 00 – Structured Cabling, Basic Materials and Methods
 10. Section 27 11 16 – Communications Cabinets, Racks, Frames and Enclosures
 11. Section 27 11 19 – Communications Termination Blocks and Patch Panels
 12. Section 27 11 23 – Communications Cable Management
 13. Section 27 11 26 – Communications Rack Mounted Power Protection and Power Strips
 14. Section 27 13 00 – Communications Interior Backbone Cabling
 15. Section 27 14 00 – Communications Outside Plant Backbone Cabling
 16. Section 27 15 00 – Communications Horizontal Cabling

1.02 REFERENCES

- A. Usage: In accordance with Division 1.
- B. American National Standards Institute (ANSI):
1. ANSI/TIA-568-C.0, Generic Telecommunications Cabling for Customer Premises, 2009
 2. ANSI/TIA-568-C.1, Commercial Building Telecommunications Cabling Standard, 2009
 3. ANSI/TIA-568-C.2, Balanced Twisted-Pair Telecommunication Cabling and Components Standard, published 2009
 4. ANSI/TIA-568-C.3, Optical Fiber Cabling Components Standard, published 2008, plus errata issued in October, 2008.
 5. TIA-569-B (2004; Amd 1 2009) Commercial Building Standard for Telecommunications Pathways and Spaces
 6. ANSI/TIA/EIA-606-A-2002, Administration Standard for Commercial Telecommunications Infrastructure.

1.03 DEFINITIONS

- A. See also Division 1.
- B. General Abbreviations used in these specifications. Refer additionally to the abbreviations list appearing on the Drawings:
- | | | |
|-----|------|--|
| 1. | ADA | Americans With Disabilities Act. |
| 2. | AFC | Above Finished Ceiling. |
| 3. | AFF | Above the Finished Floor. |
| 4. | BLDG | Building |
| 5. | CAT | Category |
| 6. | CL | Centerline |
| 7. | DIV | Division |
| 8. | (E) | Existing |
| 9. | FBO | Furnished By District's Representative |
| 10. | HR | Home Run |
| 11. | ID | Inside Diameter |
| 12. | LAN | Local Area Network |
| 13. | MAX | Maximum |
| 14. | NIC | Not In Contract. |
| 15. | OD | Outside Diameter |
| 16. | PSRH | Project Standard Receptacle Height. |
| 17. | PSSH | Project Standard Switch Height. |
| 18. | TYP | Typical |
| 19. | OFE | District's Representative Furnished Equipment. |
| 20. | UON | Unless Otherwise Noted. |
- C. Electrical and electronics terms used in the Communications Sections shall be as defined in:
- | | |
|----|----------------------|
| 1. | ANSI/TIA/EIA-568-C.0 |
| 2. | ANSI/TIA/EIA-568-C.1 |
| 3. | ANSI/TIA/EIA-568-C.2 |
| 4. | ANSI/TIA/EIA-568-C.3 |
| 5. | ANSI/TIA/EIA-569-B |
| 6. | ANSI/TIA/EIA-606-A |
| 7. | IEEE Std 100 |
| 8. | This Section. |
- D. Campus Distributor (CD) - A distributor from which the campus backbone cabling emanates. (International expression for main cross-connect (MC).)
- E. Building Distributor (BDF) - A distributor in which the building backbone cables terminate and at which connections to the campus backbone cables may be made. (International expression for intermediate cross-connect (IC).)
- F. Floor Distributor (FD) - A distributor used to connect horizontal cable and cabling subsystems or equipment. International expression for horizontal cross-connect (HC).
- G. Telecommunications Room (TR) - An enclosed space for housing telecommunications equipment, cable, terminations, and cross-connects. The room is the recognized cross-connect between the backbone cable and the horizontal cabling.

- H. Entrance Facility (EF) (Telecommunications) An entrance to the building for both private and public network service cables (including antennae) including the entrance point at the building wall and continuing to the entrance room or space.
- I. Entrance Room (ER) (Telecommunications) - A centralized space for telecommunications equipment that serves the occupants of a building. Equipment housed therein is considered distinct from a telecommunications room because of the nature of its complexity.
- J. Open Cable - Cabling that is not run in a raceway as defined by NFPA 70. This refers to cabling that is open to the space in which the cable has been installed and is therefore exposed to the environmental conditions associated with that space.
- K. Open Office - A floor space division provided by furniture, moveable partitions, or other means instead of by building walls.
- L. Pathway - A physical infrastructure utilized for the placement and routing of telecommunications cable.
- M. Reference to Named Products:
 - 1. Selected Item: Item so noted was selected based on comparative testing of similar products. Procedure for determination of equivalence is noted in the specification for the item(s).
 - 2. System Design Basis: Item so noted interacts with other system items to produce total system function. Substitution of this item may require coordinated substitution of other system items.
 - 3. Design Basis: Item so noted was used as basis for system drawings to establish features, size, etc. Use of specified equivalents may require adjustment of physical layout or wiring, but does not affect system function. No preference is implied.

1.04 SUBMITTALS

- A. Comply with Division 1 and the following:
 - 1. Submit all materials for review arranged in same order as Specifications, individually referenced to Specification Section, Paragraph and Contract Drawing number. Conform in every detail as applies to each referencing Section.
 - 2. Submit 8 ½"x 11" items bound in volumes and drawings in edge bound sets. Submit all drawings on sheets of the same size.
 - 3. Make each specified submittal as a coordinated package complete with all information specified herein. Incomplete or uncoordinated submittals will be returned with no review action.
 - 4. Progress Schedule: Comply with Division 1.
- B. Contractor and Key Personnel Experience:
 - 1. A minimum of 30 days prior to installation, submit documentation of the experience of the low voltage systems, equipment and infrastructure contractor(s) and of their key personnel.
 - 2. Qualifications shall be provided for:

- a. the low voltage systems, equipment and infrastructure contractor(s),
- b. the low voltage systems, equipment and infrastructure installers,
- c. and the supervisor(s) (if different from the installers).

3. Refer to Quality Assurance paragraph in this section for complete requirements.

C. Manufacturer's Product Data:

- 1. Manufacturer's Product Data Sheets. Collate in sequence of List of Materials.
- 2. Data sheet for each item in each Communications Section, including all accessories, clearly marked for proposed product.
- 3. Material Safety Data Sheet, where applies.
- 4. List of Materials Schedule. For each item, include:
 - a. Referencing Specification Section
 - b. Referencing Paragraph
 - c. Referencing Drawing, if specified only on plans
 - d. Manufacturer.
 - e. Model number.
 - f. Listing, including name of Nationally Recognized Testing Laboratory.
 - g. Precede each submittal book with a summary schedule, with columns for each item above and rows for each item submitted, per the example schedule below:

Specification Section	Paragraph	Contract Drawing Reference	Manufacturer	Model No.	UL/ETL/CLA Listed
27 05 00	2.03C		XYZ	123	Y
27 15 00	2.07A1		AAA	34-56	Y
		T0.1	ZZY	456	Y

D. Field (Installation) Drawings:

- 1. General:
 - a. Drawings shall present the proposed installation using the makes and models of devices proposed for use this project; replace vendor neutral nomenclature used in bid set with the actual part numbers to be installed or provide a lookup table in the drawings to permit determining the actual part number.
 - b. Where the existing systems and/or infrastructure are used and integrated into the work of the project, indicate them on drawings, including points of interface and demarcation of existing and new work.
 - c. Collate, in sequence, at least the following minimum drawings, for each infrastructure and system to be installed under the work of this contract.
- 2. Drawing index/symbol sheet.
- 3. Site plans, floor plans and reflected ceiling plans:
 - a. General:

- 1) The identifier for each termination and cable shall appear on the drawings, either directly on the floor plans, through an associated schedule or a unique identifier associated with a fully annotated single line diagram.
 - 2) Include wiring diagrams and installation details of equipment indicating proposed location, layout and arrangement, control panels, accessories, piping, ductwork, and other items that must be shown to ensure a coordinated installation. Drawings shall indicate adequate clearance for operation, maintenance, and replacement of operating equipment devices.
 - 3) At scale of Contract Documents, show:
 - a) Device locations and type
 - b) Rough-in.
 - c) Mounting height.
 - d) Conduit size.
 - e) J-hook routes
 - f) Wire type.
 - g) Wire fill.
 - 4) On the floor plans, indicate floor and wall mounted devices and pathway below a height of 7 feet above finish floor. Indicate the locations of the communications rooms and provide reference to the enlarged communications rooms plans.
 - 5) On the reflected ceiling plan, indicate ceiling and wall mounted devices and pathway above a height of 7 feet above finish floor. Indicate the locations of the communications rooms and provide reference to the enlarged communications rooms plans.
- b. Communications Infrastructure:
- 1) Provide registered communications distribution designer (RCDD) approved, drawings depicting a complete communication infrastructure in accordance with ANSI/TIA/EIA-606-A. The drawings should provide details required to prove that the distribution system shall properly support connectivity from the communications rooms including EF, ER, CD's, BD's, and FD's to the telecommunications work area outlets.
 - 2) The following drawings shall be provided as a minimum:
 - a) T1- Layout of complete building per floor - Building Area/Serving Zone Boundaries, Backbone Systems, and Horizontal Pathways. Layout of complete building per floor. The drawing indicates location of building areas, serving zones, vertical backbone diagrams, telecommunications rooms, access points, pathways, grounding system, and other systems that need to be viewed from the complete building perspective.
 - b) T-2 Serving Zones/Building Area Drawings - Drop Locations and Cable Identification (ID'S). Shows a building area or serving zone. These drawings show drop locations, telecommunications rooms, access points and detail call outs for common equipment rooms and other congested areas.

4. Enlarged Plans:
 - a. General: Indicate at least as much information as is provided in the Contract Documents, supplemented by the dimensions and arrangement of the proposed equipment, trade coordination and field conditions.
 - b. Communications Infrastructure:
 - 1) Communications Rooms Drawings:
 - a) Provide T3 drawings in accordance with EIA TIA/EIA-606-A that include telecommunications rooms plan views, pathway layout (cable tray, racks, ladder-racks, etc.), mechanical/electrical layout, and cabinet, rack, backboard and wall elevations. Include rack details, proposed layout and anchorage of equipment and appurtenances, and equipment relationship to other parts of the work including clearance for maintenance and operation.
 - b) At scale of Contract Documents, the Contractor shall submit scaled drawing elevations (showing dimensions, mounting locations and associated frames & equipment) for all required assemblies, including but not limited to:
 - (1) Rack locations
 - (2) Wall mounted plywood backboards
 - (3) Wall mounted backbone cabling and major station cable bundles.
 - (4) Wall mounted and tray mounted splice cases
 - (5) Wall mounted copper cable protectors and terminal blocks.
 - (6) Wall mounted fiber optic cable terminations.
 - (7) Clearances
 - (8) Backboard Wire and Cable Management
 - (9) Rack elevations, including
 - (10) Copper cable patch panels.
 - (11) Fiber optic cable patch panels.
 - (12) Rack mounted wire managers
 - (13) Hold clears for equipment provided by Others.
 - (14) Reference to mounting details.
 - (15) Power strips
 - (16) UPS
 - 2) Drawings may also be an enlargement of a congested area of T1 or T2 drawings.
5. System Conduit and Riser Diagrams:
 - a. General:
 - 1) Wiring diagrams shall identify circuit terminals and indicate the internal wiring for each item of equipment and the interconnection between each item of equipment.
 - 2) Single line diagram of structured wiring.
 - 3) Grounding and bonding scheme.
 - 4) Terminal cabinets.

- 5) Coordination with floor plans.
- 6) Wire runs not shown on floor plans.
- 7) Wire type.
- 8) Wire fill.
- 9) Interface to work provided by work of other Sections, District's Representative Furnished Equipment, existing equipment and/or future equipment.

6. Detail Drawings:

a. Mounting Details:

- 1) Specific details of restraints including anchor bolts submitted under the Section 27 05 29 – Hangers and Supports for Communications Systems for mounting and maximum loading at each location, showing compliance and coordination with Code and the project Architectural, Structural and Mechanical Documents.
- 2) Stamped and signed by an Engineer licensed in the Project jurisdiction for work of this type.
 - a) Submit an accompanying Engineering analysis stamped and signed by an Engineer licensed in California for work of this type, indicating that the Equipment Enclosure System will comply with California Building Code for the Project Seismic Zone when loaded with the weight of the equipment submitted.
 - b) Show calculations on drawings or in bound volume for review.
 - c) by Authorities having jurisdiction.
- 3) Show loads, type and strength of connections, sizes, dimensions, materials, etc.
- 4) Provide Details for:
 - a) Equipment Rack anchorage.
 - b) Wall Mounted Racks and Enclosures.
 - c) Cable Runway and Cable Tray.
 - d) Wall and ceiling loudspeakers weighing 20 pounds or more.

b. Faceplate and Receptacles:

- 1) Receptacle and jack arrangement for each condition.
- 2) Labeling of receptacle/jacks and plate
- 3) Plate material.
- 4) Plate finish.
- 5) Connector types.
- 6) Connector dimensioned layout.

c. Pathway:

- 1) Cable tray installation details, indicating complete system of fittings and radsussed pathways provided.
- 2) Firestopping.
- 3) Details of flexible raceway connections to be made to vibrating equipment.

- 4) Details of J-Box and sealant application for the typical conditions listed in Section 27 05 48 – Noise and Vibration Controls for Communications System, and a schedule of rooms to receive application of mastic and sealant at J-Boxes.
 - 5) An itemized list of all items of equipment to be fitted with flexible electrical connections.
 - 6) Conduit racking details.
 - d. California Access Compliance Manual and Americans with Disabilities Act (ADA) compliance.
 - e. For systems with contractor or manufacturer programmed control and human interfaces submit at least:
 - 1) Narrative of the sequence of operation.
 - 2) Color, full-size layouts of each touchpanel and/or computer screen (menu) image, cross-referenced to the sequence of operations.
 - 3) Show chaining of sub-menus.
 - f. Terminal cabinets: Terminations.
 - g. Voice cable plant: Cut sheets for use by District's Representative's Telephone Systems Contractor.
- E. Test Plan:
 1. Submit complete documentation of the proposed test plan and equipment to be used to document that the performance of the cabling, equipment, sub-systems and complete systems installed under the work of this project conform with the performance standards outlined in each specification section.
 2. Submit not less than 45 days prior to the proposed test date. Include procedures for certification, validation, and testing.
- F. Test Reports:
 1. Manufacturer's Field Reports: Factory reel tests.
 2. Project Site Test Reports:
 - a. Submit following system completion and prior to and as condition precedent to Acceptance Review and Testing of the Work of this Section.
 - b. Schedule: Submit test reports in timely manner relative to Project schedule such that the District Representative may conduct verification of submitted test data without delay of scheduled progress.
 - c. Project Site test report.
 - d. Content: Include at least:
 - 1) Time and date of test.
 - 2) Personnel conducting test.
 - 3) Test equipment, including serial and date of calibration.
 - 4) Test object.
 - 5) Procedure used.

- 6) Results of test
 - 7) Numerical or graphical presentation.
- e. Submit copy of final results on paper and in electronic form, organized by circuit number, consistent with circuit numbering scheme used in preparing submittal drawings and in labeling receptacles and terminations.
- 1) Submit machine-generated documentation and raw data of all test results in electronic form on CD-R media.
 - 2) Where the electronic documentation requires use of a proprietary computer program to view the data, provide the District's Representative with 1 licensed copy of the software.

1.05 QUALITY ASSURANCE

- A. Designated Supervisor: Provide a designated supervisor present and in responsible charge in the fabrication shop and on the Project Site during all phases of installation and testing of the Work of this Section. This supervisor shall be the same individual through the execution of the Work unless illness, loss of personnel, or other circumstances reasonably beyond the control of the Contractor intervene.
- B. Reference Documents: At all times when the work is in progress, maintain at the workplace, fabrication shop or Project Site as applies.
1. A complete set of the latest stamped, actioned submittals of record.
 2. A complete set of manufacturer's original operation, instruction and service manuals for each equipment item.
- C. Standard Products:
1. Telecommunications Equipment. Provide telecommunications materials and equipment that are products of manufacturers regularly engaged in the production of such products which are of equal material, design and workmanship. Products shall have been in satisfactory commercial or industrial use for 1 year prior to bid opening. The 1-year period shall include applications of equipment and materials under similar circumstances and of similar size. The product shall have been on sale on the commercial market through advertisements, manufacturers' catalogs, or brochures during the 1-year period.
 - a. Alternative Qualifications. Products having less than a 1-year field service record will be acceptable if a certified record of satisfactory field operation for not less than 4000 hours, exclusive of the manufacturers' factory or laboratory tests, is furnished.
 2. Material and Equipment Manufacturing Date: Products manufactured more than 3 years prior to date of delivery to site shall not be used, unless specified otherwise.
- D. Test Equipment:
1. Requirements:
 - a. Maintain and operate test equipment at the fabrication shop and the job site for both routine and Acceptance Testing of the Work of this Section.

- b. Maintain test equipment at the job site while work is in progress from installation of equipment racks until District's Representative's Acceptance of this Work; thereafter remove all of this test equipment from the job site.
- c. Unless otherwise indicated, test equipment shall remain property of the Contractor.
- d. Provide all required test cables, jigs and adapters.
- e. Provide equipment with traceable calibration, with calibration date not greater than one year prior to the date of the use of the equipment to perform the specified testing.

E. Qualifications:

1. Key Personnel, General:

- a. Indicate the proposed key persons that are currently employed by the telecommunications contractor or who have a commitment to the low voltage systems and infrastructure contractor for the work of this project. All key persons shall be employed by the low voltage systems and infrastructure contractor at the date of issuance of this project, or if not, have a commitment to the low voltage systems and infrastructure contractor to work on this project by the date that the bid was due to the District's Representative.
- b. Note that only the key personnel approved by the District Representative in the successful proposal shall perform work on this project's low voltage systems and infrastructure systems. Key personnel shall function in the same roles in this contract, as they functioned in the offered successful experience. Any substitutions for the low voltage systems and infrastructure contractor's key personnel requires approval from the District's Representative.

2. Telecommunications Contractor:

- a. The telecommunications contractor shall be a firm which is regularly and professionally engaged in the business of the applications, installation, and testing of the specified telecommunications systems and equipment.
 - 1) The telecommunications contractor shall demonstrate experience in providing successful telecommunications systems within the past 3 years.
 - 2) Submit documentation for a minimum of three and a maximum of five successful telecommunication system installations for the telecommunications contractor.
- b. Key Personnel:
 - 1) Provide key personnel who are regularly and professionally engaged in the business of the application, installation and testing of the specified telecommunications systems and equipment. There may be one key person or more key persons proposed for this project depending upon how many of the key roles each has successfully provided. Each of the key personnel shall demonstrate experience in providing successful telecommunications systems within the past 3 years.

- 2) Supervisors and installers assigned to the installation of this system or any of its components shall be Building Industry Consulting Services International (BICSI) Registered Cabling Installers, Technician Level. Submit documentation of current BICSI certification for each of the key personnel. In lieu of BICSI certification, supervisors and installers assigned to the installation of this system or any of its components shall have a minimum of 3 years experience in the installation of the specified copper and fiber optic cable and components. They shall have factory or factory approved certification from each equipment manufacturer indicating that they are qualified to install and test the provided products. Submit documentation for a minimum of three and a maximum of five successful telecommunication system installations for each of the key personnel. Documentation for each key person shall include at least two successful system installations provided that are equivalent in system size and in construction complexity to the telecommunications system proposed for this project. Include specific experience in installing and testing telecommunications systems and provide the names and locations of at least two project installations successfully completed using optical fiber and copper telecommunications cabling systems. All of the existing telecommunications system installations offered by the key persons as successful experience shall have been in successful full-time service for at least 18 months prior to the issuance date for this project. Provide the name and role of the key person, the title, location, and completed installation date of the referenced project, the referenced project owner point of contact information including name, organization, title, and telephone number, and generally, the referenced project description including system size and construction complexity.

3. Minimum Communications Infrastructure Manufacturer Qualifications:

- a. Cabling, equipment and hardware manufacturers shall have a minimum of 3 years experience in the manufacturing, assembly, and factory testing of components which comply with ANSI/TIA/EIA-568-C.1, ANSI/TIA/EIA-568-B.2 and ANSI/TIA/EIA-568-C.3.

1.06 REGULATORY REQUIREMENTS

A. Regulations Applicable: Including but not limited to those defined in Division 1.

1. Nothing in the Contract Documents shall be construed to permit Work not conforming to applicable laws, ordinances, rules, or regulations.
2. Safety Agency Listing: All devices provided under the Work of this Section which are connected to the Project electrical system shall be listed by a Nationally Recognized Testing Laboratory, and shall be so labeled.
3. In each of the publications referred to herein, consider the advisory provisions to be mandatory, as though the word, "shall" had been substituted for "should" wherever it appears. Interpret references in these publications to the "authority having jurisdiction," or words of similar meaning, to mean the District's Representative. Equipment, materials, installation, and workmanship shall be in accordance with the mandatory and advisory provisions of NFPA 70 unless more stringent requirements are specified or indicated.

1.07 DELIVERY, STORAGE AND HANDLING

- A. Procedures: In accordance with Division 1 and as specified in the individual sections of Division 27.
- B. General: Provide protection from weather, moisture, extreme heat and cold, dirt, dust, and other contaminants for telecommunications cabling and equipment placed in storage.

1.08 ENVIRONMENTAL REQUIREMENTS

- A. Connecting hardware shall be rated for operation under ambient conditions of 32 to 140 degrees F and in the range of 0 to 95 percent relative humidity, non-condensing.

1.09 SEQUENCING

- A. Not Used.

1.10 OPERATING AND MAINTENANCE DATA

- A. Commercial off the shelf manuals shall be furnished for operation, installation, configuration, and maintenance of products provided as a part of the communications cabling and systems. Precede the manuals with a systems narrative specific to this Project, outlining the major systems functionality, the major systems components, and identifying which manuals document the performance of which subsystems.

- 1. Submit Operation and Maintenance Data and as specified herein not later than 2 months prior to the date of beneficial occupancy or as specified in Division 1, whichever is sooner.

1.11 PROJECT RECORD DOCUMENTS

- A. Comply with the following. Include at least as much information as required for the submittal drawings.

- 1. Record Drawings:

- a. CAD: Use a computer aided drafting (CAD) system in the preparation of record drawings for this Project. CAD system shall produce files in AutoCAD® .DWG format, version 2004 or later.
- b. Except where prohibited by Contract, District's Representative will furnish CAD backgrounds in AutoCAD® .DWG format, for use by the Contractor in preparing Record Drawings.
- c. Contractor shall be responsible for updating building and communications plans to reflect as-built conditions.
 - 1) Indicate actual work on Drawings; indicate actual products used, replace vendor neutral nomenclature used in bid set with makes and models of actual installed devices.
- d. Disk copy of Record Drawings: Provide 2 separate copies of each drawing file in the format noted above. Submit on CD-R disk or DVD-R.
- e. Reproduceables: As required by Division 1.

2. Provide T5 drawings including documentation on cables and termination hardware in accordance with ANSI/TIA/EIA-606-A. T5 drawings shall include schedules to show information for cut-overs and cable plant management, patch panel layouts and cover plate assignments, cross-connect information and connecting terminal layout as a minimum. Provide the following T5 drawing documentation as a minimum:
 - a. Cables - A record of installed cable shall be provided in accordance with ANSI/EIA/TIA-606-A. The cable records shall include the required data fields for each cable and complete end-to-end circuit report for each complete circuit from the assigned outlet to the entry facility in accordance with ANSI/TIA/EIA-606-A. Include manufacture date of cable with submittal.
 - b. Termination Hardware - A record of installed patch panels, cross-connect points, distribution frames, terminating block arrangements and type, and outlets shall be provided in accordance with EIA TIA/EIA-606-A. Documentation shall include the required data fields as a minimum in accordance with EIA TIA/EIA-606-A.

1.12 WARRANTY SERVICE

- A. In addition to provisions of Division 1, provide the following:
 1. Response Time: Provide a qualified technician familiar with the work at the Project Site within 24 hours after receipt of a notice of malfunction. Provide the District Representative with telephone number attended 8 hours a day, 5 days a week, to be called in the event of a malfunction.
- B. Provide all additional Warranties as defined in each Communication Systems Section.

1.13 ACCEPTANCE REVIEW AND TESTING PROCEDURES

- A. Complete all Work of this Section. Submit Test Report. Submit review copies of Operating and Maintenance Manuals, less reduced set of Record Drawings. Notify the District Representative in writing that the Work of these Sections is complete and fully complies with the Contract Documents. Request Acceptance Review and Testing. The District Representative will conduct Verification of Submitted Test Data, and otherwise direct testing and adjustment of this Work. These procedures may be performed at any hour of the day or night as required by the District Representative to comply with the Project Schedule and avoid conflict with Residents. Provide all specified personnel and equipment at any time without claim for additional cost or time.
- B. Personnel: Provide services of the designated supervisor and additional technicians familiar with work of this Section. Provide quantity of technicians as required to comply with Project Schedule.
- C. In Addition, Provide:
 1. All tools appropriate for performance of adjustment of and corrections to this Work. Include spare wire and connectors and specified tooling for application.
 2. Ladders, scaffolding and/or lifts as required to access high devices.
 3. All test equipment.
 4. Complete set of latest stamped, actioned submittals of record for reference.
 5. Complete set of Test Reports.

6. Complete set of manufacturer's original operation, instruction and service manuals for each equipment item for reference.
 7. Demonstrate: Complete operation of all systems and equipment, including Portable Equipment.
 8. Adjust: As directed by the District's Representative.
 9. Correct: In timely manner, failure to comply with the Contract Documents, as reasonably determined by the District's Representative.
- D. Temporary Equipment: Provide and operate, without claim for additional cost or time, temporary equipment and/or systems to provide reasonably equivalent function, as determined by the District's Representative, in place of the Work of this Section which is incomplete or found not in conformance with the Contract Documents as of seven (7) days prior to the scheduled completion date. Provide such temporary equipment until Acceptance of the Work of this Section. Thereafter, remove such temporary equipment.

1.14 CLOSEOUT

- A. Punch List: Perform any and all remedial work, at no claim for additional cost or time. Where required, retest and submit Test Report. Notify the District Representative of completion of Punch List.
- B. Portable Equipment: Furnish all portable equipment and spares to the District's Representative, along with complete documentation of the materials presented. Where applicable, furnish portable equipment in the original manufacturer's packing.
- C. Operating and Maintenance Data: Install framed operating and maintenance instructions. Submit Manuals.
- D. Project Record Documents: Submit print and digital copies. Digital files shall be in AutoCAD drawing format.
- E. Keys: If applicable, replace construction locks with permanent locks. Provide 5 sets of keys to the District's Representative.
- F. Instruction: Conduct specified instruction.
- G. Warranty: Submit Warranty dated to run from date of Acceptance of the Work of this Section.

PART 2 - PRODUCTS

2.01 GENERAL

- A. Where a particular material, device, piece of equipment or system is specified directly, the current manufacturer's specification for the same shall be considered to be a part of these specifications, as if completely contained herein in every detail.
- B. Each material, device or piece of equipment shall comply with all of the manufacturer's current published specifications for that item.
- C. Products shall be made by manufacturers regularly engaged in the production of such products.
- D. Provide quantity as shown on Contract Drawings, or as otherwise indicated.

- E. Provide all auxiliary and incidental materials and equipment necessary for the operation and protection of the Work of this Section as if specified in full herein.
- F. Unless recycled content is specified, provide new materials.
- G. Provide the manufacturer's latest design/model, permanently labeled with the manufacturer's name, model number and serial number.
- H. Where products are of similar type or use, provide products of the same manufacturer, unless otherwise indicated.
- I. Components:
 - 1. UL or third party certified. Cabling and interconnecting hardware and components for telecommunications systems shall be UL listed or third party independent testing laboratory certified, and shall comply with NFPA 70 and conform to the requirements specified herein.
 - 2. Where equipment or materials are specified to conform to industry and technical society reference standards of the organizations, submit proof of such compliance.
 - a. The label or listing by the specified organization will be acceptable evidence of compliance.
 - b. In lieu of the label or listing, submit a certificate from an independent testing organization, competent to perform testing, and approved by the District's Representative.
 - c. The certificate shall state that the item has been tested in accordance with the specified organization's test methods and that the item complies with the specified organization's reference standard.
- J. Enclosures:
 - 1. Provide steel frames and enclosures designed and wired to eliminate all induced currents.
 - 2. Make bolted connections with self-locking devices.
- K. Finishes: Any item or component of the Work of this Section which is visible shall comply with the following:
 - 1. Finishes noted or scheduled on the Contract Drawings take precedence.
 - 2. Where design location requires that products, materials or equipment are visible to the public, no manufacturer's logos larger than 1/2 inch shall be visible. Unless otherwise noted or directed, neatly remove or permanently paint out such logos.
 - 3.
 - 4. Where finishes are not noted or otherwise defined in the Contract Documents, submit manufacturer's standard finish samples for selection by the District's Representative.

PART 3 - EXECUTION

3.01 EXAMINATION

- A. Examine existing conditions before starting work. Submit conflicts in a timely manner for resolution.

3.02 PREPARATION

- A. Prepare and sequence the work to minimize disruption to each room environment and existing communications systems.
- B. Protection: Cover all computers, electronic equipment, desks, chairs, furniture and other articles when working at ceiling level and/or performing dust producing tasks.

3.03 REPAIR AND RESTORATION

- A. Where working in spaces occupied by the District's Representative, return to their original positions any furniture or articles relocated to perform the work.

3.04 CLEANING

- A. Where working in spaces occupied by the District's Representative:
 - 1. Immediately after completing work within each space, clean up and remove all materials, scrap and dust.
 - 2. All scrap material in work area shall be picked up and removed from the building at the end of each day. See also Division 1 for additional requirements.
 - 3. All dust resulting from work performed shall be vacuumed up daily.
 - 4. All scrap material shall be removed from base and disposed of in an authorized disposal site. Refer to Division 1 for Project Procedures.

END OF SECTION

SECTION 27 05 26
GROUNDING AND BONDING FOR COMMUNICATIONS SYSTEMS

PART 1 - GENERAL

1.01 SCOPE OF WORK

A. Section includes grounding and bonding of Communications Work, including but not limited to:

1. Communications Raceways
2. Cable Runway
3. Cable Shields
4. Protector Fields
5. Communications cabinets and enclosures.

B. Related Work Under Other Sections:

1. Related Sections:

- a. Section 27 05 00 – Common Work Results for Communications
- b. Section 27 05 29 – Hangers and Supports for Communications Systems
- c. Section 27 05 33 – Conduits and Backboxes for Communications Systems
- d. Section 27 05 39 – Surface Raceways for Communications Systems
- e. Section 27 05 36 – Cable Trays for Communications Systems
- f. Section 27 05 43 – Underground Ducts and Raceways for Communications Systems
- g. Section 27 10 00 – Structured Cabling, Basic Materials and Methods
- h. Section 27 11 16 – Communications Cabinets, Racks, Frames and Enclosures
- i. Section 27 11 19 – Communications Termination Blocks and Patch Panels
- j. Section 27 11 23 – Communications Cable Management
- k. Section 27 11 26 – Communications Rack Mounted Power Protection and Power Strips
- l. Section 27 13 00 – Communications Interior Backbone Cabling
- m. Section 27 14 00 – Communications Outside Plant Backbone Cabling
- n. Section 27 15 00 – Communications Horizontal Cabling

1.02 SYSTEM DESCRIPTION

- A. Provide telecommunications system grounding conductor as described herein and indicate on drawings.
- B. Except as otherwise indicated, the complete communications installation including the metallic conduits and raceways, cable trays, boxes, cabinets, racks, panels, cable shields and lightning protectors shall be completely and effectively grounded in accordance with all code requirements, whether or not such connections are specifically shown or specified.
- C. Resistance:
1. Resistance from the farthest ground bus through the ground electrode to earth shall not exceed 5 Ohms or the requirements of ANSI-J-STD-607-A-2002, whichever is more restrictive.
 2. Resistance from Communications racks buss ground to Ufer ground must remain less than or equal to the electrical ground presented at A/C outlet for electronic equipment in the communications rack

1.03 REFERENCES

- A. American National Standards Institute (ANSI):
 - 1. ANSI-J-STD-607-A-2002 Commercial Building Grounding (Earthing) and Bonding Requirements for Telecommunications.
 - 2. ANSI/TIA/EIA-606-A-2002 Administration Standard for Commercial Telecommunications Infrastructure.
- B. IEEE: IEEE C135.30 (1988) Standard for Zinc-Coated Ferrous Ground Rods for Overhead or Underground Line Construction
- C. Underwriters Laboratories (UL): UL 467 (1993); R 2004 Grounding and Bonding Equipment

1.04 SUBMITTALS

- A. Conform with the requirements of Division 1 and Section 27 05 00 Common Work Results for Communications.

PART 2 - PRODUCTS

2.01 MANUFACTURERS

- A. Equal products by the following manufacturers will be considered providing that all features of the specified product are provided:
 - 1. Ground Rod:
 - a. High strength high carbon steel, with electrolytically bonded jacket of copper on surface.
 - b. 5/8" diameter minimum.
 - c. 5' long minimum.
 - d. UL spec. 467
 - e. ANSI C-33.8-1072.
 - f. Manufacturer:
 - 1) Allied Bolt
 - 2) Inwesco 12A60
 - 3) Blackburn
 - 4) Cooper Power Systems
 - 5) Weaver.
 - 6) Erico "Cadweld" Products, Inc.
 - 7) ITT Blackburn.
 - 8) Or equal.
 - 2. Ground Wells:
 - a. Christy Concrete Products, Inc.
 - b. Forni Corp.
 - c. Or equal.
 - 3. Ground Bushings, Connectors, Jumpers and Bus:
 - a. O-Z/Gedney.
 - b. Thomas & Betts Corp.

- c. Or equal.
- 4. Compression Connector Lug:
 - a. Panduit
 - b. B-Line SB-479 Series
 - c. Thomas & Betts
 - d. Or equal.
- 5. Telecommunications Ground Bus Bar:
 - a. CPI Telecommunications Grounding BusBars
 - b. B-Line
 - c. Panduit
 - d. or equal.
- 6. Rack and Cabinet Grounding:
 - a. Panduit Structured Ground Kit
 - b. Chatsworth Products Inc.
 - c. or equal.
- 7. Bonding Ribbon:
 - a. Annealed solid copper 3/8 inch wide x 1/16 inch thick, tin plated.
 - b. Manufacturer:
 - 1) Inwesco 12A55
 - 2) Corning Cable Systems
 - 3) Preformed Line Products.
 - 4) or equal.
- 8. Bonding Ribbon Clamp:
 - a. Soft lead
 - b. 1/16 inch thick
 - c. Bolt hole for attachment
 - d. Manufacturer:
 - 1) Inwesco 12A56
 - 2) Corning Cable Systems
 - 3) Preformed Line Products.
 - 4) Or equal.
- 9. Fargo Clamp:
 - a. Cast copper, silver plated, furnished with copper bolt.
 - b. RUS Listed
 - c. Manufacturer:
 - 1) Allied Bolt
 - 2) Inwesco 12A57
 - 3) Corning Cable Systems
 - 4) or equal.
- 10. Ground Inserts:

- a. Cast Bronze with 1/4 copper Rod.
- b. Provide minimum one each vault.
- c. Provide minimum two each maintenance hole.
- d. Manufacturer:
 - 1) Inwesco 12H69
 - 2) or equal by vault or manhole manufacturer.
 - 3) or equal.

2.02 GROUND CONDUCTORS

- A. General purpose insulated: UL listed and code sized copper conductor, with dual rated THHN/THWN insulation, color identified green. Where continuous color-coded conductors are not commercially available, provide a minimum 4" long color band with green, non-aging, plastic tape in accordance with NEC.
- B. Outside Plant Applications: Grounding conductors shall be bare copper, meeting ASTM B 8 soft-drawn unless otherwise indicated. Aluminum is not acceptable.
- C. Bonding pigtails: Insulated copper conductor, identified green, sized per code, and provided with termination screw or lug. Provide solid conductors for #10 AWG or smaller and stranded conductors for #8 AWG or larger.

2.03 COMPRESSION CONNECTOR LUG

- A. Description:
 - 1. Connector lug with compression connection to conductor.
 - 2. Copper alloy body.
 - 3. Provide lug size to match conductor being terminated.
 - 4. Provide 2 hole pattern lugs.
 - 5. Provide each lug with silicon bronze hardware, including 2 bolts, 2 split lock washers and 2 nuts.

2.04 INSULATED GROUNDING BUSHINGS

- A. Plated malleable iron or steel body with 150 degree Centigrade molded plastic insulating throat and lay-in grounding lug.

2.05 CONNECTIONS TO PIPE

- A. For Cable to Pipe: UL listed bolted connection complying with NEC requirements.

2.06 CONNECTIONS TO STRUCTURAL STEEL, GROUND RODS, OR SPLICES

- A. Where required by the Drawings or Specifications, grounding conductors shall be spliced together, connected to ground rods or connected to structural steel using exothermic welds or high pressure compression type connectors.
 - 1. Exothermic welds shall be used for cable-to-cable and cable-to-ground rod and for cable to structural steel surfaces. Exothermic weld kits shall be as manufactured by Cadweld, Thermoweld or equal. Each particular type of weld shall use a kit unique to that type of weld.

2. High-pressure compression type connectors shall be used for cable-to-cable and cable-to-ground rod connections. Connections shall be as manufactured by Thomas & Betts #53000 series, Burndy "Hy-Ground" or equal.

2.07 EXTRA FLEXIBLE, FLAT BONDING JUMPERS

- A. Where required by the drawing or specified herein.

PART 3 - EXECUTION

3.01 GENERAL

- A. Provide Grounding and Bonding according to the most restrictive requirements of:
 1. ANSI-J-STD-607-A.
 2. National Electrical Code Article 250 and references therein.
 3. National Electrical Code Article 800.
- B. In the event of conflicting requirements, National Electrical Code requirements shall prevail.
- C. Point of Connection: Under Work of this Section, make connections to Communications Ground Busbars provided under Work of Division 26.
- D. Mechanical Connections:
 1. Make connections bare metal to bare metal.
 2. Where required, remove paint to bare metal, make grounding or bonding connection, and touch up paint.
 3. Torque threaded fasteners to manufacturer's recommended values.
- E. Underground Communications Structure Ground Rods:
 1. Ground rods shall be installed at new communications handholes, vaults and pullboxes installed by the work of this Project. A ground rod shall be installed at new communications handholes, vaults, manholes and pullboxes installed by the work of this Project, or at existing underground structures used by the work of this Project lacking a ground rod.
 - a. Provide two ground rods at maintenance holes.
 - b. Elsewhere provide one ground rod.
 2. Ground rods shall be driven into the earth before the manhole floor is poured so that approximately 4 inches of the ground rod will extend above the manhole floor. When precast concrete manholes are used, the top of the ground rod may be below the manhole floor and a No. 1/0 AWG ground conductor brought into the manhole through a watertight sleeve in the manhole wall.
 3. Ground rods installed in manholes, handholes, or concrete pullboxes shall be connected to cable racks, cable-pulling irons, the cable shielding, metallic sheath, and armor at each cable joint or splice by means of a No. 4 AWG braided tinned copper wire. Connections to metallic cable sheaths shall be by means of tinned terminals soldered to ground wires and to cable sheaths.

- a. Care shall be taken in soldering not to damage metallic cable sheaths or shields. Ground rods shall be protected with a double wrapping of pressure-sensitive plastic tape for a distance of 2 inches above and 6 inches below concrete penetrations.
 - b. Grounding electrode conductors shall be neatly and firmly attached to manhole or handhole walls and the amount of exposed bare wire shall be held to a minimum.
- F. Compression Connections: Make compression connections with the lug or fitting manufacturer's recommended tooling, with the tooling set to the recommended force and stroke.
- G. Communications Raceways and Sleeves:
- 1. Bond metallic raceway and sleeves to the Communications Ground Busbar at the Communications Room that serves the related Communications Receptacle.
 - 2. Where a metallic raceway connects 2 or more Communications Rooms, bond to the Communications Ground Busbar at each.
- H. Cable Tray and Cable Runway:
- 1. Coordinate with the Work of Section 27 05 36 – Cable Trays for Communications Systems.
 - 2. Provide manufacturer's bonding clips, plates or jumpers as required to comply with the UL Classified conditions for use as an equipment grounding conductor.
 - 3. Bond the Cable Runway to the Communications Ground Busbar at the Communications Room served.
- I. Cable Shields: Comply with National Electrical Code Article 800.
- J. Protector Fields: Comply with National Electrical Code Article 800.
- K. Communications Cabinets and Enclosures: Bond each cabinet to the Communications Ground Busbar at the Communications Room.
- L. Emergency/Information Telephone enclosures: Bond as detailed on Communications Drawings.
- M. Communications Broadband Systems:
- 1. Comply with National Electrical Code Article 820.
 - 2. Ground Broadband passives as shown on Communications Drawings.

3.02 LABELING

- A. Provide labeling according to the requirements of:
- 1. ANSI/TIA/EIA-606-A.
 - 2. Section 27 05 53 Identification for Communications Systems.

END OF SECTION

**SECTION 27 05 29
HANGERS AND SUPPORTS FOR COMMUNICATIONS SYSTEMS**

PART 1 - GENERAL

1.01 SCOPE OF WORK

- A. The work covered under this section consists of the furnishing of all necessary labor, supervision, materials, equipment, and services to completely execute the provision of communications supports and cable hook system as described in this specification, including but not limited to:
1. Strut supports
 2. Cable Hooks (J-hooks)
 3. Beam clamps
 4. Concrete Fasteners
 5. Touch-Up Materials
 6. Conduit supports.
 7. Equipment supports.
 8. Fastening hardware.
- B. Related Work: Consult all other Sections, determine the extent and character of related work and properly coordinate work specified herein with that specified elsewhere to produce a complete installation.
1. Division 3: Cast-in-place concrete. Concrete equipment pads.
 2. Division 5: Miscellaneous metals. Hangers for electrical equipment.
 3. Division 9: Ceiling suspension systems. Slack fixture support wires.
 4. Section 27 05 00 – Common Work Results for Communications
 5. Section 27 05 26 – Grounding and Bonding for Communications Systems
 6. Section 27 05 33 – Conduits and Backboxes for Communications Systems
 7. Section 27 05 36 – Cable Trays for Communications Systems
 8. Section 27 05 39 – Surface Raceways for Communications Systems
 9. Section 27 05 48 – Noise and Vibration Controls for Communications Systems
 10. Section 27 05 53 – Identification for Communications Systems
 11. Section 27 10 00 – Structured Cabling, Basic Materials and Methods
 12. Section 27 11 16 – Communications Cabinets, Racks, Frames and Enclosures
 13. Section 27 11 23 – Communications Cable Management
 14. Section 27 13 00 – Communications Interior Backbone Cabling
 15. Section 27 14 00 – Communications Outside Plant Backbone Cabling
 16. Section 27 15 00 – Communications Horizontal Cabling

1.02 SYSTEM DESCRIPTION

- A. Provide devices specified in this Section and related Sections for support of communications equipment specified for this Project.
- B. Provide support systems that are adequate for the weight of equipment, conduit and wiring to be supported.

1.03 REFERENCES

- A. American Society For Testing and Materials (ASTM):
1. ASTM A123/A123M-02 Standard Specification for Zinc (Hot-Dip Galvanized) Coatings on Iron and Steel Products.

2. ASTM A153/A153M-04 Standard Specification for Zinc Coating (Hot-Dip) on Iron and Steel Hardware.
 3. ASTM B633-98e1 Specification for Electro-deposited Coatings of Zinc on Iron and Steel.
 4. ASTM A653/A653M-04a Standard Specification for Steel Sheet, Zinc-Coated (Galvanized) or Zinc-Iron Alloy-Coated (Galvannealed) by the Hot-Dip Process.
- B. American National Standards Institute (ANSI):
1. ANSI/TIA-568-C.0, Generic Telecommunications Cabling for Customer Premises, 2009
 2. ANSI/TIA-568-C.1, Commercial Building Telecommunications Cabling Standard, 2009
 3. ANSI/TIA-568-C.2, Balanced Twisted-Pair Telecommunication Cabling and Components Standard, published 2009
 4. ANSI/TIA-568-C.3, Optical Fiber Cabling Components Standard, published 2008, plus errata issued in October, 2008
 5. ANSI/ TIA/ EIA 569-B Commercial Building Standard for Telecommunications Pathways and Spaces
- C. National Fire Protection Association: NFPA 70, National Electrical Code.

1.04 SUBMITTALS

- A. Conform with the requirements of Section 27 05 00 - Common Work Results for Communications and the following:
1. As part of the project submittals, the contractor to provide engineered shop drawings indicating the proposed design for mounting all work of this Division weighing more than 20 pounds, inclusive of mounting systems, and for equipment mounted at the exterior, inclusive of its effective wind load under conditions the range of conditions experience.
 - a. Shop drawings to be accompanied by anchorage calculations indicating that it shall remain attached to the mounting surface after experiencing forces in conformance with California Code of Regulations, Title 24, 2007 California Building Code.
 - b. Structural Calculations shall be prepared and signed by a California Registered Structural Engineer. Specify proof loads for drilled-in anchors, if used.

1.05 QUALITY ASSURANCE

- A. All materials, equipment and parts comprising the units specified herein shall be new and unused, and of current manufacturer.
- B. Cable hooks shall be listed and labeled by Underwriters Laboratories (UL) as required.
- C. Cable hooks shall have the manufacturers name and part number stamped in the part itself for identification.

PART 2 - PRODUCTS

2.01 SUPPORTING DEVICES

A. General: Supports to be sized to suit load and selected to match mounting conditions.

B. Manufacturers:

1. Equal products by the following manufacturers will be considered providing that all features of the specified product are provided:

a. Concrete Fasteners:

- 1) Phillips "Red-Head".
- 2) Remington.
- 3) Ramset.
- 4) Hilti
- 5) Simpson Strong-Tie
- 6) or equal.

b. Concrete Inserts and Construction Channel:

- 1) Unistrut Corp.
- 2) GS Metals "Globe Strut."
- 3) Thomas & Betts "Kindorf" Corp.
- 4) Or equal.

c. Conduit Straps:

- 1) O-Z/Gedney.
- 2) Erico "Caddy" Fastening Products.
- 3) Thomas & Betts "Kindorf" Corp.
- 4) Or equal.

d. Beam Clamps:

- 1) Cooper B-Line
- 2) SuperStrut
- 3) Unistrut
- 4) or equal

e. Aircraft Cable Sway Braces:

- 1) Mason Industries
- 2) M.W. Sausse/Vibrex
- 3) Loos & Company, Inc.
- 4) or equal.

C. Concrete Fasteners:

1. Provide expansion-shield type concrete anchors.

2. Provide powder driven concrete fasteners with washers. Obtain approval from District Representative prior to use.

- D. Concrete Inserts: Provide pressed galvanized steel, concrete spot insert, with oval slot capable of accepting square or rectangular support nuts of ¼ inch to ½ inch diameter thread for rod support.
- E. Aircraft Cable Sway Braces: Steel rope sized to meet load.
- F. Construction Channel:
 - 1. Construction:
 - a. 1-5/8" square galvanized channel formed from U.S.S.G No. 12 or 0.109 inch cold formed steel with 17/32-inch diameter bolt holes, and 1-1/2 inch on center in the base of the channel.
 - b. 10 foot sections.
 - 2. All supporting materials by same manufacturer.
- G. Beam Clamps: Malleable iron electro-galvanized steel beam clamps selected to match building structural steel members.
- H. Conduit Straps:
 - 1. One hole strap, steel or malleable iron, with malleable iron clamp-back spacer for surface mounted wall and ceiling applications.
 - a. Use malleable strap with spacers for exterior and wet locations.
 - b. Use steel strap without spacers for interior locations.
 - 2. Steel channel conduit strap for support from construction channel.
 - 3. Steel conduit hanger for pendant support with threaded rod
 - 4. Steel wire conduit support strap for support from independent #12 gauge hanger wires.
- I. Threaded rods, couplings, screws and nuts: Electrolytically coated with zinc, 2 oz. zinc per square foot of surface, ASTM A123 or A153.
- J. Miscellaneous Parts: Hot dipped galvanized after fabrication; after cutting, de-burring and hole drilling. Coated with zinc, 2 oz. zinc per square foot of surface, ASTM A123 or A153.
- K. Paint/Tape for Touch-up: Zinc: CRC "Zinc-It", Glyptal, Enterprise Galvanizing "Galambra", or equal.

2.02 CABLE HANGERS

- A. Ceiling Hung J-Hooks:
 - 1. Drawing Reference(s):
 - a. WMJ
 - b. ACJ
 - 2. Features/Functions/Construction:
 - a. Specifically intended to carry the load of up to 50 communications cables without applying excess forces to cables at bottom of bundle.

- b. Integral broad bottom edge to spread cable load with flat bottom and provide a minimum of 1-5/8 inch cable bearing surface.
 - c. Integral hanger rod attachment hardware at top.
 - d. Load rated for application.
 - e. Incorporates smooth 90-degree radiused edges to prevent snagging cable jackets on installation.
 - f. Designed so the mounting hardware is recessed to prevent cable damage.
 - g. Integral mechanical cable latch retainer to provide containment of cables within the hook. The retainer shall be removable and reusable.
 - h. Suitable for direct attachment to walls, hanger rods, beam flanges, purlins, strut, floor posts, etc. to meet job conditions.
 - i. Multi-tiered cable hooks to be used where required to provide separate cabling compartments, or where additional capacity is needed.
 - j. Finishes:
 - 1) Cable hooks for non-corrosive areas shall be pre-galvanized steel, ASTM A653. Where additional strength is required, cable hooks shall be spring steel with a zinc-plated finish, ASTM B633, SC3.
 - 2) Cable hooks for corrosive areas shall be stainless steel, AISI Type 304.
3. Manufacturer:
- a. Cooper B-Line series BCH21, BCH32, BCH64
 - b. Caddy/Erico CableCat
 - c. or equal.

PART 3 - EXECUTION

3.01 GENERAL

- A. The District Representative reserves the right to request additional supports where in their sole opinion said supports are required. Any additional supports shall be installed at no additional cost to the Government.

3.02 EXAMINATION

- A. Thoroughly examine site conditions for acceptance of supporting device installation to verify conformance with manufacturer and specification tolerances. Do not commence with installation until all conditions are made satisfactory.

3.03 PREPARATION

- A. Coordinate size, shape and location of concrete pads required for equipment installation with Division 3, Cast-in-place Concrete Specification.

- B. Layout support devices to maintain headroom, neat mechanical appearance and to support the equipment loads.
- C. Where shown on the Drawings or Specifications, install freestanding communications equipment on concrete pads.

3.04 INSTALLATION

- A. Furnish and install supporting devices as noted throughout Division 27.
- B. Communications device and conduit supports shall be independent of all other system supports that are not structural elements of the building, unless otherwise noted.
- C. Fasten hanger rods, conduit clamps, outlet and junction boxes to building structure using precast inserts, expansion anchors, preset inserts or beam clamps.
- D. Use toggle bolts or hollow wall fasteners in hollow masonry, plaster or gypsum board partitions and walls.
- E. Use expansion anchors or preset inserts in solid masonry walls.
- F. Use self-drilling anchors, expansion anchor, or preset inserts on concrete surfaces.
- G. Use sheet metal screws in sheet metal studs and wood screws in wood construction.
- H. Do not fasten supports to piping, ductwork, mechanical equipment, conduit, or acoustical ceiling suspension wires.
- I. Do not drill structural steel members unless first approved in writing by the District's Representative.
- J. Fabricate supports from structural steel or steel channel, rigidly welded or bolted to present a neat appearance. Use hexagon head bolts with spring lock washers under all nuts.
- K. Install surface-mounted cabinets with minimum of four anchors. Provide additional support backing in stud walls prior to sheet rocking as required to adequately support cabinets and panels.
- L. Bridge studs top and bottom with channels to support flush mounted cabinets and panelboards in stud walls.

3.05 ERECTION OF METAL SUPPORTS

- A. Cut, fit, and place miscellaneous metal fabrications accurately in location, alignment, and elevation to support and anchor electrical materials and equipment.
- B. Field Welding: Comply with AWS "Structural Welding Code."

3.06 WOOD SUPPORTS

- A. Cut, fit, and place wood grounds, nailers, blocking, and anchorage accurately in location, alignment, and elevation to support and anchor electrical materials and equipment.

3.07 ANCHORAGE

- A. Identify each item requiring seismic restraint installation in accordance with CBC Chapter 16A.
 - 1. Include floor mounted items weighing more than 400 pounds and wall mounted or suspended items weighing more than 20 pounds.
 - 2. Machinery, equipment, and their components including their support, bracing, and anchorage, designed by manufacturers or suppliers, shall be designed in accordance with the following criteria:
 - a. Design to resist seismic forces in accordance with the most restrictive requirements of CBC Chapter 16A, including but not limited to Paragraph 1615.10.14.
 - b. As part of the equipment submittals, the contractor shall provide anchorage calculations for floor and wall mounted communications equipment so that it shall remain attached to the mounting surface after experiencing forces in conformance with requirements of Chapter 16A of the CBC.
 - c. Structural Calculations shall be prepared and signed by a California Registered Structural Engineer. Specify proof loads for drilled-in anchors, if used.
- B. The contractor shall recommend the method of anchoring the equipment to the mounting surface and shall provide the Contractor with the assembly dimensions, weights and approximate centers of gravity.
- C. All floor mounted, free standing electrical equipment such as racks and cabinets, etc. shall be securely fastened to the floor structure.

3.08 DISTRIBUTION PATHWAY VIA CEILING HUNG CABLE HOOKS (J-HOOKS)

- A. Void, Plenum or Suspended Ceiling Exposed Cable Installation. Where drawings specifically show or permit use of exposed cable installation in voids, conform to the most restrictive requirements of Code, TIA-569-B and this Section.
- B. Provide support for all cabling. Do not place or attach directly to T-bar grid, concealed spline grid, flexible or rigid ductwork, HVAC registers, sprinkler piping or fixtures, light fixtures or building structure. Conform to the National Electric Code.
- C. Placement:
 - 1. All pathways created by ceiling hung cable hooks shall be reviewed by the District Representative prior to installation.
 - 2. Ceiling hung cable hooks and cabling supported by same shall not obscure access to access doors, hatches, air dampers, valves, filter sections, VAV boxes, cable trays, junction boxes, pull boxes or similar areas of access required by other trades.
 - 3. All ceiling hung cable hooks shall be mounted close enough together such that upon completion of the station cable installation a minimum amount of cable droop occurs between adjacent rings. The distance between supporting rings shall not exceed 48 inches or as required by the current edition of TIA-569-B.
- D. Refer to the separation requirements listed in Section 27 15 00 – Communications Horizontal Cabling for minimum distances from electrical power and other electro-magnetic sources.

- E. Follow manufacturer's recommendations for allowable fill capacity for each size of cable hook.
1. Cable hooks shall be capable of supporting a minimum of 30 pounds with a safety factor of 3.
 2. Spring steel cable hooks shall be capable of supporting a minimum of 100 pounds with a safety factor of 3 where extra strength is required.
 3. Where aggregate cable bundle supported by ceiling hung cable hooks exceeds either the rated cable or weight load limit of the ceiling hung cable hook system, provide ceiling basket tray – Type CTW – as specified in Section 27 05 36.

END OF SECTION

**SECTION 27 05 33
CONDUITS AND BACKBOXES FOR COMMUNICATIONS SYSTEMS**

PART 1 - GENERAL

1.01 SCOPE OF WORK

- A. Provide telecommunications pathways in accordance with EIA TIA/EIA-569-B, as specified in this Section and as shown on the plans. Provide system furniture pathways in accordance with UL 1286. Provision of all low voltage Communications Systems Pathway and Electronic Security and Safety System Pathway, including:
1. Rigid steel conduit and fittings.
 2. PVC insulated rigid steel conduit and fittings.
 3. Intermediate metal conduit and fittings.
 4. Electrical metallic tubing and fittings.
 5. Flexible metallic conduit and fittings.
 6. Liquidtight flexible metallic conduit and fittings.
 7. Miscellaneous conduit fittings and products.

1.02 RELATED WORK IN OTHER SECTIONS

- A. Related work: Consult all other Sections, determine the extent and character of related work and properly coordinate work specified herein with that specified elsewhere to produce a complete installation.
1. Division 1: Cutting and patching.
 2. Division 7: Sheet metal flashing and trim.
 3. Division 9: Painting. Exposed conduit and other devices.
 4. Section 27 05 00 – Common Work Results for Communications.
 5. Section 27 05 26 – Grounding and Bonding for Communications Systems
 6. Section 27 05 29 – Hangers and Supports for Communications Systems
 7. Section 27 05 33 – Conduits and Backboxes for Communications Systems
 8. Section 27 05 36 – Cable Trays for Communications Systems
 9. Section 27 05 39 – Surface Raceways for Communications Systems
 10. Section 27 05 48 – Noise and Vibration for Communications Systems
 11. Section 27 10 00 – Structured Cabling, Basic Materials and Methods
 12. Section 27 13 00 – Communications Interior Backbone Cabling
 13. Section 27 14 00 – Communications Outside Plant Backbone Cabling
 14. Section 27 15 00 – Communications Horizontal Cabling

1.03 REFERENCES

- A. Usage: In accordance with Division 1.
1. American National Standards Institute (ANSI):
 - a. ANSI C80.1 1994 Rigid Steel Conduit - Zinc Coated
 - b. ANSI C80.3 1991 Electrical Metallic Tubing - Zinc Coated
 2. National Electrical Manufacturers Association (NEMA):
 - a. NEMA 250-2003 Enclosures for Electrical Equipment (1000 Volts Maximum)
 - b. NEMA FB 1 (ANSI/NEMA FB 1-2003) Fittings, Cast Metal Boxes and Conduit Bodies for Conduit, Electrical Metallic Tubing, and Cable

- c. FB 2.10 2000 Selection and Installation Guidelines For Fittings For Use With Non-Flexible Metallic Conduit Or Tubing (Rigid Metal Conduit, Intermediate Metal Conduit, And Electrical Metallic Tubing).
 - d. FB 2.20 2000 Selection and Installation Guidelines for Fittings for use with Flexible Electrical Conduit and Cable
 - e. NEMA ICS 6 1988 (Rev. 1) Enclosures for Industrial Control and Systems
 - f. NEMA OS 3-2002 Selection and Installation Guidelines for Electrical Outlet Boxes.
 - g. NEMA RN 1-1998 Polyvinyl Chloride (PVC) Externally Coated Galvanized Rigid Steel Conduit and Intermediate Metal Conduit.
 - h. NEMA TC 7 2000 Smooth Wall Coilable Polyethylene Electrical Plastic Duct
 - i. NEMA TC 13 2000 Electrical Nonmetallic Tubing (ENT).
 - j. NEMA TC 14 1984(R 1986) Filament-Wound Reinforced Thermosetting Resin Conduit and Fittings.
3. Department of the Navy: IA PUB-5239-22, Oct 2003 Information Assurance (IA) Protected Distribution System (PDS) Publication, Oct03.
4. Underwriters Laboratories, Inc. (UL):
- a. UL 1 2000 Flexible Metal Conduit
 - b. UL 6 2004 Electrical Rigid Metal Conduit - Steel
 - c. UL 50 (1995; R 1999, Bul. 2001) Enclosures for Electrical Equipment
 - d. UL 360 1986 (Bul. 1991) (R 1993) Liquid-Tight Flexible Steel Conduit
 - e. UL 514A 1991 (R 2004) Metallic Outlet Boxes
 - f. UL 514B 1989 (R 2004) Conduit, Tubing and Cable Fittings
 - g. UL 514C 1996 (R 2000) Nonmetallic Outlet Boxes, Flush-Device Boxes, and Covers.
 - h. UL 651 1989 (R 1989) (Bul. 1993) Schedule 40 and 80 Rigid PVC Conduit.
 - i. UL 797 1993 (R 2004) Electrical Metallic Tubing - Steel
 - j. UL 1242 1983 (R1993) (Bul. 1993) Intermediate Metal Conduit.
 - k. UL 1286(1999; R 2001, Bul. 2002) Office Furnishings
 - l. UL 1479 Fire Tests of Through Penetration Firestops
 - m. UL Fire Resistance Directories

1.04 SUBMITTALS

- A. Conform with the requirements of Division 1 and Section 27 05 00 - Common Work Results for Communications.

1.05 QUALITY ASSURANCE

- A. All materials, equipment and parts comprising the units specified herein shall be new and unused, and of current manufacturer.
- B. Only products and applications listed in this Section may be used on the project unless otherwise submitted and approved by the District's Representative.

PART 2 - PRODUCTS

2.01 GENERAL

- A. Provide the following types of conduit systems listed by their commonly used generic name.

2.02 RACEWAY

A. Manufacturers:

1. Raceway:

- a. Allied Tube and Conduit Co.
- b. Triangle PWC, Inc.
- c. Western Tube and Conduit Corp.
- d. Spring City Electrical Manufacturing Co.
- e. Occidental Coating Co. (OCAL).
- f. Alflex Corp.
- g. American Flexible Metal Conduit Co.
- h. Anaconda.
- i. Or equal.

2. Fittings:

- a. Appleton Electric Co.
- b. OZ/Gedney.
- c. Thomas & Betts Corp.
- d. Spring City Electrical Manufacturing Co.
- e. Occidental Coating Co. (OCAL).
- f. Carlon.
- g. or equal.

B. Rigid Steel Conduit:

1. Drawing and Spec Reference: RSC.

2. Construction:

- a. Conduit: Full weight, threaded, hot-dip galvanized steel, conforming to ANSI C80.1 and UL 6.
- b. Standard threaded couplings, locknuts, bushings, and elbows: Only materials of steel or malleable iron are acceptable. Locknuts shall be bonding type with sharp edges for digging into the metal wall of an enclosure.
- c. Three piece couplings: Electroplated, cast malleable iron.
- d. Insulating bushings: Threaded polypropylene or thermosetting phenolic rated 150 degree C minimum.
- e. Insulated grounding bushings: Threaded cast malleable iron body with insulated throat and steel "lay-in" ground lug with compression screw.
- f. Insulated metallic bushings: Threaded cast malleable iron body with plastic insulated throat rated 150 degrees C.
- g. All fittings and connectors shall be threaded.

C. Coated Rigid Steel Conduit:

1. Drawing and Spec Reference: CRSC.

2. Conduit: Full weight, threaded, hot-dip galvanized steel, conforming to ANSI C80.1 and NEMA RN-1 with nominal 40 mil thermoplastic vinyl coating, heat fused and bonded to the exterior of the conduit.
 3. Fittings:
 - a. Conduit couplings and connectors shall be as specified for galvanized rigid steel conduit and shall be factory PVC coated with an insulating jacket equivalent to that of the coated material.
 - b. Fittings over-sleeve to extend 1 conduit diameter or 1-1/2" beyond fitting, whichever is less.
 4. Performance: Tensile Strength: 3500 psi.
 5. Approvals:
 - a. NEMA RN1 (Type 40 - 40 mils thick)
 - b. CalTrans Type 2
 6. Manufacturers:
 - a. Plastibond by RobRoy Industries.
 - b. Occal-40 by Occidental Coating Company.
 - c. KorKap by Plastic Applicators.
 - d. Ocal-Blue
 - e. or equal.
- D. Intermediate Metal Conduit:
1. Drawing Reference: IMC.
 2. Conduit: Hot dip galvanized steel meeting the requirements of NEC Article 345 and conforming to ANSI C80.6 and UL 1242.
 3. Fittings: Conduit couplings, connector and bushing shall be as specified for galvanized rigid steel conduit. Integral retractable type IMC couplings are also acceptable.
- E. Electrical Metallic Tubing:
1. Drawing and Spec Reference: EMT.
 2. Conduit: Shall be formed of cold rolled strip steel, electrical resistance welded continuously along the longitudinal seam and hot dip galvanized after fabrication.
 3. Conduit shall conform to ANSI C80.3 specifications and shall meet UL classifications.
 4. Set screw type couplings: Electroplated, steel or cast malleable iron, UL listed concrete tight. Use set screw type couplings with four setscrews each of conduit sizes over 2 inches. Setscrews shall be of case hardened steel with hex head and cup point to firmly seat in wall of conduit for positive grounding.
 5. Set screw type connectors: Electroplated steel or cast malleable iron UL listed concrete tight with male hub and insulated plastic throat, 150 degree C temperature rated. Setscrew shall be same as for couplings.

6. Raintight couplings: Electroplate steel or cast malleable iron; UL listed raintight and concrete tight, using gland and ring compression type construction.
7. Raintight connectors: Electroplated steel or cast malleable iron, UL listed raintight and concrete tight, with insulated throat, using gland and ring compression type construction.

F. Flexible Conduit:

1. Drawing Reference: FLEX
2. Construction:
 - a. Flexible steel, zinc coated on both inside and outside by hot-dipping process.
 - b. Interlocking spirally wound continuous steel strip.
 - c. 3/4" minimum size.
3. Fittings: Connectors shall be of the single screw clamp variety with steel or cast malleable iron bodies and threaded male hubs with insulated throats. Exception: Pressure cast screw-in connectors shall be acceptable for fixture connection in suspended ceilings and cut-in outlet boxes within existing furred walls.
4. Approvals: UL 1.

G. Liquidtight Flexible Metallic Conduit:

1. Drawing Reference: Liquidtight.
2. Conduit: Shall be fabricated in continuous lengths from galvanized steel strips, interlocking spirally wound, covered with extruded liquid tight jacket of polyvinyl chloride (PVC) and conforming to UL 360. Provide conduit with a continuous copper-bonding conductor wound spirally between the convolutions.
3. Fittings: Connector body and gland nut shall be of cadmium plated steel or cast malleable iron, with tapered, male, threaded hub; insulated throat and neoprene "O" ring gasket recessed into the face of the stop nut. The clamping gland shall be of molded nylon with an integral brass push-in ferrule.

2.03 MISCELLANEOUS CONDUIT FITTINGS AND PRODUCTS

A. General:

1. UL 514B.
2. Listed in UL Electrical Construction Materials List.

B. Conduit Fittings, Insulated Throat Grounding Bushings:

1. Description:
 - a. Threaded for Rigid Steel Conduit and Intermediate Metal Conduit.
 - b. UL Listed for use with copper conductors.
 - c. Thermoplastic insulated liner for 105 degrees Celsius.
 - d. Body of malleable iron, zinc plated; or die cast zinc.
2. Manufacturer:
 - a. Thomas & Betts (Steel City) BG-801 Series

- b. O-Z/Gedney
 - c. or equal.
- C. Epoxy: J-B Weld (U.S. Navy preferred product).
- D. One Way/Breakaway Nut for Sealing NEMA Type PDS Pullboxes: Subject to approval of District Representative and SPAWAR – Tamperproof Screw Company, Inc. of New York BAN series.
- E. Watertight conduit entrance seals: Steel or cast malleable iron bodies and pressure clamps with PVC sleeve, neoprene sealing grommets and PVC coated steel pressure rings. Fittings shall be supplied with neoprene sealing rings between the body and PVC sleeve.
- F. Watertight cable sealing bushings: One piece, compression molded sealing ring with PVC coated steel pressure disks, stainless steel sealing screws and zinc plated cast malleable iron locking collar.
- G. Expansion fittings: Multi-piece unit comprised of a hot dip galvanized malleable iron or steel body and outside pressure bussing designed to allow a maximum of 4" conduit movement (2" in either direction). Furnish with external braid tinned copper bonding jumper. Unit shall be UL listed for wet or dry locations.
- H. Expansion/deflection couplings: Multi-piece unit comprised of a neoprene sleeve with internal flexible tinned copper braid attached to bronze end couplings with stainless steel bands. Coupling shall accommodate .75-inch deflection, expansion, or contraction in any direction, and allow 30-degree angular deflections. Flexible, corrosion-resistant, watertight, moisture and heat resistant molded rubber jacket and stainless steel jacket clamps. Unit shall comply with UL467 and UL514.
 - 1. Manufacturer:
 - a. OZ/Gedney Type DX
 - b. Steel City Type EDF
 - c. or equal.
- I. Fire Rated Penetration Seals:
 - 1. UL classified.
 - 2. Conduit penetrations in fire rated separation shall be sealed with a UL classified assembly consisting of fill, void or cavity materials.
 - 3. The fire rated sealant material shall be the product best suited for each type of penetration, and may be a caulk, putty, composite sheet or wrap/strip.
 - 4. Penetrations of rated floors shall be sealed with an assembly having both F and T ratings at least equal to rating of the floor.
 - 5. Penetrations of rated walls shall be sealed with an assembly having an F rating at least equal to the rating of the wall.
- J. Standard Products not Herein Specified:
 - 1. Submit for review a listing of standard electrical conduit hardware and fittings not herein specified prior to use or installation, i.e. locknuts, bushings, etc.

2. Listing shall include manufacturers name, part numbers, and a written description of the item indicating type of material and construction.
3. Miscellaneous components shall be equal in quality, material, and construction to similar items herein specified.

K. Hazardous area fittings: UL listed for the application.

2.04 BOXES AND ENCLOSURES

A. Junction and Device Boxes:

1. Drawing References: As shown on Symbol Schedule.
2. Construction:
 - a. Concealed/Flush Mounted.
 - b. One or two piece welded knockout boxes.
 - c. UL 514A, cadmium or zinc-coated 1.25 oz/sq. ft., if ferrous metal.
 - d. Pressed sheet steel, for indoor locations.
 - e. UL 514C approved if non-metallic.
 - f. At hollow masonry, tile walls and plaster walls, provide with device rings as required.
 - g. Surface Mounted:
 - 1) Exterior - Conform to the Junction and/or PullBox construction scheduled on the Plans. Where construction not otherwise scheduled or noted on the plans, conform to the following.:
 - a) Cast iron or aluminum with threaded hubs and mounting lugs.
 - b) Gasketed cover with spring lid.
 - 2) Concrete Floor Embedded:
 - a) Cast iron concrete pour boxes with screwed brass cover, unless otherwise noted.
 - b) Cadmium plated screw cover attachment at least 6" on center.
 - h. If size not otherwise noted, at least 4S (4" square) by 2-1/8" deep, or Code minimum size, whichever is larger.
 - i. Provide complete with approved type of connectors and required accessories, including attachment lugs or hangers. Provide raised device covers as required to accept scheduled device.
3. Approvals: UL 514A.
4. Manufacturers:
 - a. Interior:

- 1) Steel City.
 - 2) Any meeting criteria
 - 3) or equal.
- b. Exterior, exposed with cover of same construction.
- 1) Appleton
 - 2) Pyle-National
 - 3) or equal.
- c. Other Conditions: Any meeting approvals and requirements.
- B. 5" Square Junction Box:
1. Drawing References: As indicated on Symbol Schedule.
 2. Construction:
 - a. 5 in. Square x 2.875 in. Deep Metal backbox with an integral cable management system.
 - b. Use on Class 2 and Class 3 Remote-Control, Signaling and Power-Limited Circuits only.
 3. Manufacturer:
 - a. Randl Industries, Inc. 5 Square Telecommunications Outlet Box T-55017 with D-51G000 one gang ring.
 - b. Or equal.

2.05 TERMINAL BOXES, PULL CANS AND ENCLOSURES

- A. Terminal Cabinets:
1. Drawing Reference: As Scheduled.
 2. Construction:
 - a. Zinc Coated Sheet Steel, code gauge with standard concentric knockouts for conduit terminations.
 - b. Interior dimensions not less than those scheduled.
 - c. Finish: Manufacturer's standard gray baked enamel finish.
 - d. Covers: Trim fitted, continuous hinged steel door, flush catch - lockable and keyed to match. Screw fastened doors not acceptable.
 - 1) Door face to be not less than 95% of panel interior dimensions.
 - e. Provide with 3/4" fire retardant treated ply backboard.
 3. Mounting:

- a. Flush cabinets shall be furnished with concealed trim clamps and shall be not less than 4 inches deep.
 - b. Surface cabinets shall be furnished with screw cover trim, flush hinged door and shall not be less than 6 inches deep.
 - c. Interior Applications: NEMA 250 Type 1, unless otherwise noted. Refer to plans and schedules.
 - d. Exterior Applications: NEMA 250 Type - As scheduled, not less than NEMA 3R.
4. Manufacturers:
- a. B-Line Electrical Enclosures
 - b. Circle AW Products.
 - c. Hammond
 - d. Henessey.
 - e. Hoffman.
 - f. Myers Electric Products
 - g. Rittal.
 - h. Or equal.

PART 3 - EXECUTION

3.01 CONDUIT APPLICATION

- A. General: Install the following types of conduits and fittings in the locations listed, unless otherwise noted in the drawings:
 1. Exterior, Exposed:
 - a. Type RSC for applications up to 8 feet AFF or to first pull box, whichever is first, applications subject to physical abuse or for applications greater than 4" diameter.
 - b. EMT acceptable in all other applications not noted above up to 4", where used in conjunction with specified Raintight (compression) couplers.
 2. Interior, Exposed, Wet and Damp Locations:
 - a. Type RSC.
 - b. At interior locations over 8 feet above finished floor, EMT acceptable.
 3. Interior, Hazardous Locations:
 - a. Type RSC
 - b. Type IMC, where permitted by the NEC.
 4. Interior, Exposed or Concealed, Dry Locations:
 - a. RSC, if subject to physical abuse.
 - b. EMT, if not subject to physical abuse.
 5. Interior, Concealed, Damp Locations, including in Masonry Walls: RSC.
 6. Embedded in Concrete:

- a. RSC or rigid non-metallic conduit.
- b. PVC Type DB-120.

7. Transition from Walls to Open Plan Furniture Systems: Liquidtight.

3.02 GENERAL REQUIREMENTS

- A. Refer to the manufacturer's instructions and conform thereto.
- B. Distribution Pathway via EMT Raceway:
 - 1. The EMT conduit is to be installed meeting the NEC handbook Article 348 Installation Specifications.
 - 2. Provide escutcheon plates for all through wall conduit stubs.
 - 3. All ends of conduits shall be cut square, reamed and fitted with insulated bushing.
 - 4. All conduit which passes through fire walls shall be sealed with fire stop putty after all station wire has been installed.

3.03 MOUNTING AND INSTALLATION - BOXES AND ENCLOSURES

- A. Conform to the more restrictive of NEMA OS 3-2002 and the following.
- B. Provide backboxes at all communications systems devices. Installation of device plates directly to wall surface without use of a backbox, unless specifically directed on plans, is unacceptable.
- C. The distance between pull boxes shall not exceed 150 feet or more than two 90 degree bends.
- D. Align boxes plumb with floor and surrounding construction. At door frames, locate 4" from frame. Verify placement with District Representative details to ensure that box clears all trim, etc.
- E. Support and fasten boxes securely. At stud walls use rigid bar hangers, attached to hanger with stud and nut.
- F. At existing locations, provide cutting, patching and finishing as required to maintain or restore finishes so that resulting installation is integrated into the Architectural decor of the particular location.
- G. Mounting Height: the mounting height of a wall-mounted outlet box is defined as the height from the finished floor to the horizontal center line of the cover plate.
- H. Mount outlet boxes with the long axis vertical. Three or more gang boxes shall be mounted with the long axis horizontal.
- I. Install wiring jacks and outlet devices only in boxes which are clean; free from excess building materials, dirt, and debris.
- J. Install wiring jacks and outlet devices after wiring work is complete.

3.04 SUPPORT

- A. Provide supports for raceways as specified in Section 27 05 29 – Hangers and Supports for Communications Systems.

- B. All raceways installed in exposed dry locations shall be grouped in a like arrangement and supported by means of conduit straps, wall brackets or trapeze hangers in accordance with Code and the requirements of the this Section. Fasten all hangers from the building structural system.
- C. Provide supports and mounting attachments per the most restrictive of Code and the following.

Raceway Size (inches)	No of cables in run	Location	Support Spacing (feet)	
			RSC	EMT
Horizontal Runs				
½, 3/4	1-2	Flat Ceiling Wall Runs	5	5
½, 3/4	1-2	Where access limited to building structure	7	7
½, 3/4	3≥	Any location	7	7
1≥	1-2	Flat ceiling or wall	6	6
1≥	1-2	Where access limited to building structure	10	10
1≥	3≥	Any locations	10	10
Any	Any	Concealed	10	10
Vertical Runs				
½, 3/4	Any	Exposed	7	7
1, 1-1/4	Any	Exposed	8	8
1-1/2≥	Any	Exposed	10	10

- D. Install no more than one coupling or device between supports.
- E. Conduit Support as specified in Section 27 05 29 – Hangers and Supports for Communications Systems.

3.05 PENETRATIONS

- A. Gypsum Wall Board Penetrations: Provide circular penetrations maximum 1/8" inch larger than outer diameter of conduit being used. On both sides of the wall fill space between conduit and wall with joint compound, depth to match gypsum board thickness.
- B. Install UL listed fire-stop system whenever a raceway penetrates a firewall in conformance with the manufacturer's directions, the published systems assembly requirements, and the 2006 IBC, whichever is the most restrictive. At cable tray penetrations, provide pillow type removable fire stop per the 2006 IBC, the published systems assembly requirements and the manufacturer's directions, whichever is the most restrictive.
- C. All communications systems conduit openings in walls and floors are the responsibility of the Contractor. Install sleeves shown on the drawings when the concrete is poured. Any openings required after the concrete has set maybe core drilled.

3.06 RACEWAY INSTALLATION, GENERAL

- A. Raceway runs are shown schematically. Install concealed unless specifically shown otherwise. Supports, pull boxes, junction boxes and similar generally not indicated. Provide where designated.
1. Install exposed conduit and raceway parallel and perpendicular to nearby surfaces or exposed structural members, and follow the surface contours. Level and square conduit and raceway runs.

2. Raceway runs shall be mechanically and electrically continuous between all each equipment rack and utility demarcation point, receptacle and/or surface raceway strip, as applies.
3. Each conduit shall enter and be securely connected to a cabinet, junction box, pull box, or outlet by means of a locknut on the outside and a bushing on the inside or by means of a liquid-tight, threaded, self-locking, cold-weld type wedge adapter.
4. Bends:
 - a. All bends or elbows shall have a minimum radius as follows:

Conduit Size	Min. Radius (Inches)
3/4"	8
1"	12
1-1/4"	18
2"	24
2-1/2"	24
3"	30
3-1/2"	30
4"	30
5"	36
6"	42

- b. Use factory elbows or machine bends for conduit bends 1-1/4" and larger.
 5. Make bends and offsets so the inside diameter is not effectively reduced. Make bends in parallel or banked runs from the same center line so that the bends are parallel.
 6. Install at least one (1) 3/8", 200 pound strength nylon pull cord in all empty raceways.
 7. Raceways crossing building expansion joints or in straight runs exceeding 100 feet shall be provided with UL listed expansion fittings.
 8. Install conduit seals and drains to prevent accumulated moisture in conduits from entering Communications System enclosures.
- B. Do not install conduit in concrete slabs unless specifically directed by District's Representative. Embedded conduits in concrete slab walls, and columns shall be installed in center third between upper and lower layers of reinforcing steel as directed by the District's Representative. Space conduits 8" on center except at cabinet locations where slab thickness shall be increased as directed by the District's Representative.
- C. All conduits to be kept 12" away from steam or hot water lines. Install horizontal conduit and raceway runs below water and steam piping.
- D. Conduit dropping down to equipment shall be as straight as possible without any offsets, parallel or perpendicular to walls, ceilings and other building features.
- E. Conduit installed on any equipment shall be run symmetrical with the equipment and in such a manner as to:
1. Not to be exposed to damage;
 2. Not interfere with access to components of the equipment that will interfere with maintenance operation or;

3. Whenever an installation such as that listed occurs, the Contractor shall make all necessary changes at no cost to the District.
 - F. All cut ends of conduit, scratches, tool marks, etc. on any metallic raceway installed in the ground or on the exterior of the building shall be treated with two coats of specified Touch Up Paint/Tape.
 - G. Exposed conduit and metallic surface raceway installed in finished spaces shall be painted to match surrounding surfaces using paint and methods directed by the District's Representative.
 - H. All raceways stubbing up into equipment or racks shall be sealed. Raceways with conductors shall be plugged with duct-seal. Spare raceways shall be capped. Prevent foreign matter from entering conduit and raceway; use temporary closure protection. Replace conduits containing concrete, varnish or other foreign material.
 - I. Complete installation of conduit and raceway runs before starting installation of cables/wires within conduit and raceway.
 - J. Use specified conduit and raceway fittings that are of types compatible with the associated conduit and raceway and suitable for the use and location. Join and terminate conduit and raceway with fittings designed and approved for the purpose of the conduit and raceway system and make up tight.
 - K. Where chase nipples are used, align the raceway and coupling square to the box and tighten the chase nipple so no threads are exposed.
 - L. Horizontal conduit or EMT runs, where required and permitted, shall be installed as close to ceiling or ceiling beams as practical.
 - M. Conduit and EMT connected to wall outlets shall be run in such a manner that they will not cross water, steam or waste pipes or radiator branches.
 - N. Conduit and EMT shall not be run through beams, purlins or columns except where permission is granted by District Representative in writing.
 - O. Bond installed metallic raceway in accordance with the requirements of the NEC.
 - P.
- 3.07 HAZARDOUS LOCATIONS
- A. Use rigid steel conduit only.
 - B. Install UL listed sealing fittings that prevent passage of explosive vapors in accordance with the manufacturers written instructions. Locate fittings at suitable, accessible locations and fill them with UL-listed sealing compound. For concealed raceways, install each fitting in a flush steel box with a blank coverplate having a finish similar to that of adjacent plates or surfaces.
 - C. Install raceway sealing fittings at the following points and elsewhere as indicated where conduits enter or leave hazardous locations.
- 3.08 REUSE OF EXISTING CONDUIT
- A. Existing conduit is to be used as a pathway only where so shown on the drawings.
 - B. Prior to beginning work involving the use of an existing conduit, the Contractor shall consult with the District Representative in order to establish whether or not the conduit contains active service.

- D. If no active service exists within the conduit, all cable is to be removed, and work is to proceed.
- E. If active service does exist within the conduit and it has been determined that service needs to be disrupted, then work on that conduit shall not proceed until a schedule of service outage has been established by District's Representative. Once given permission to proceed, the Contractor shall within the time period of one (1) working day; remove the old cable, install, terminate and test the new cables, and notify the District Representative the work using the specific conduit has been completed. The District Representative shall be responsible for the disconnection and reconnecting of the active service cross-connects within the terminal closet(s).
- F. Conduit Preparation Procedure:
 - 1. Remove existing wires and cables (if any).
 - 2. Run a mandrel ½" smaller than the inside diameter of the conduit through the conduit receiving new wires and cables.
 - 3. If the specified size mandrel will not pass through the existing conduit, start with a smaller size mandrel and increase mandrel size until the specified sized mandrel will pass.
 - 4. Run a wire brush and clean rag with an outside diameter 1/8" larger than the inside of the conduit through the conduit receiving new wires and cables.
 - 5. Repeat above until conduit is clean and materials detrimental to the wire and cables to be installed no longer exit conduit with the clean rag.

3.09 STATION CABLE PATHWAY INSTALLATION

- A. Cut In Boxes and Station Outlet Boxes:
 - 1. Unless otherwise noted on the plans, all cut in boxes and surface station outlet boxes are to be installed at a height of 36" A.F.F. (above finished floor) to center, except for those intended to be used for telephone wall jacks. Those plates or boxes that are to be used for telephone wall jacks shall be installed at a height of 54" A.F.F to center.
 - 2. All station outlets shall be installed so that their edges are parallel to the vertical and horizontal edges of the surface on which they are mounted.

END OF SECTION

SECTION 27 05 39
SURFACE RACEWAYS FOR COMMUNICATIONS SYSTEMS

PART 1 - GENERAL

1.01 SCOPE OF WORK

- A. Metallic Surface Raceways
- B. Non-Metallic Surface Raceway
- C. Surface Raceway Fittings

1.02 RELATED WORK UNDER OTHER SECTIONS

- A. Section 27 05 00 – Common Work Results for Communications
- B. Section 27 05 26 – Grounding and Bonding for Communications Systems
- C. Section 27 05 29 – Hangers and Supports for Communications Systems
- D. Section 27 05 33 – Conduits and Backboxes for Communications Systems
- E. Section 27 05 36 – Cable Trays for Communications Systems
- F. Section 27 05 48 – Noise, Vibration and Seismic Controls for Communications Systems
- G. Section 27 05 53 – Identification for Communications Systems
- H. Section 27 10 00 – Structured Cabling, Basic Materials and Methods
- I. Section 27 13 00 – Communications Interior Backbone Cabling
- J. Section 27 14 00 – Communications Outside Plant Backbone Cabling
- K. Section 27 15 00 – Communications Horizontal Cabling

1.03 REFERENCES

- A. Usage: In accordance with Division 1.
 - 1. American National Standards Institute (ANSI):
 - a. ANSI/TIA/EIA-569-B-2004 Commercial Building Standards for Telecommunications Pathways and Spaces.
 - b. ANSI/TIA-568-C.0, Generic Telecommunications Cabling for Customer Premises, 2009.
 - 2. Underwriters Laboratories, Inc. (UL):
 - a. UL 94 -1996 (R 2001), Tests for Flammability of Plastic Materials for Parts in Devices and Appliances .
 - b. UL 514C - 1988 (R 1989) Nonmetallic Outlet Boxes, Flush-Device Boxes, and Covers.

1.04 SUBMITTALS

- A. Conform with the requirements of Division 1 and Section 27 05 00 - Common Work Results for Communications.

PART 2 - PRODUCTS

2.01 GENERAL

- A. Products provided under the work of this Section shall provide the following minimum characteristics:
1. Approvals:
 - a. U.L Listed
 - b. Multi-chamber surface raceway shall conform to NEC 352B for simultaneous power and telecommunications use.
 2. Meet or exceed the requirements of ANSI/TIA/EIA 569-B for a surface raceway system.
 3. Fittings shall incorporate radiussed corners such that wiring cannot be placed therein with bend radius less than the minimum bend radius specified in ANSI/EIA/TIA-568C.1.
 4. Raceway base shall be designed to be securely fastened to mounting surface per manufacturer's recommendations using mechanical fasteners. Systems requiring use of adhesive fasteners will not be accepted.
 5. Raceway system shall include fittings for connection and change of raceway direction and/or plane of installation.
 6. Available in-line raceway connector fittings shall include at least:
 - a. External Elbow
 - b. Flat Elbow
 - c. Internal Elbow
 - d. End Cap
 - e. Entrance End Cap
 - f. Splice Cover
 - g. Tee
 - h. Cable clips to retain contents in overhead installation. Alternatively, provide separate cable ties and independent restraint for same.
 7. System shall accommodate connection to trade standard boxes and fittings through accessory boxes and transition pieces.
 8. Trade connections, device boxes and mounting systems shall not reduce fill capacity, except where specifically scheduled.
 9. System shall include device plates of types to meet requirements shown on Communication Systems drawings.
 10. Available device mounting boxes shall include at least:
 - a. Raised Device Box
 - b. 2-gang Raised Device Box
 - c. In-Line Device Box

11. System shall include device plates of types to meet requirements shown on Communication Systems drawings.
12. Available device plates shall include at least:
 - a. Single Receptacle Plate
 - b. Duplex Receptacle Plate (NEMA 106)
 - c. Duplex - Duplex (Quadplex) Plate
 - d. Ring to secure 3rd party communications plates and jack subframes as specified in Section 27 15 00.

2.02 SURFACE RACEWAY

A. Surface Raceway, Non-Metallic:

1. Drawing & Spec Reference: #SR*, where "#" denotes number of chambers, "*" denotes cross sectional area of each chamber in square inches.
2. Construction:
 - a. Single Chamber, 1 Square Inch:
 - 1) Drawing and reference designation: 1SR1
 - 2) Two piece construction or hinged single piece.
 - 3) System components to provide at least a one (1) inch bend radius at corners.
 - b. Single Chamber, 2 Square Inches:
 - 1) Drawing and reference designation: 1SR2
 - 2) Two piece construction.
 - 3) System components to provide at least a one (1) inch bend radius at corners.
 - 4) Dimensional Constraint: Minimum inside clearance from base to cover, 2.5 inches.
 - c. Dual Chamber, 2 Square Inches:
 - 1) Drawing and reference designation: 2SR2, WM 5400
 - 2) Two piece construction.
 - 3) At least 3.7 square inches of fill areas in each of two chambers.
 - 4) System components to provide at least a one (1) inch bend radius at corners.
 - d. Color: Electrical Ivory.
 - e. Two chamber surface raceway shall have two adjacent chambers separated by removable horizontal dividers. System and installation shall not compromise separation of services.
 - f. Keyed cover plate shall require tool for removal.
3. Approvals: Plastic meeting UL 94 V-0 flammability rating.
4. Manufacturers, subject to the above:
 - a. One chamber, 2 inch (1SR1, 1SR2): Wiremold. PN10 (Design Basis).

- b. Two chamber, 5.25 inch wide (2SR2, WM 5400): Wiremold 5400TB Series (Design Basis to match existing inventory).

PART 3 - EXECUTION

3.01 APPLICATION

- A. Surface raceway installed in fire rated exitways shall be metal surface raceway.

3.02 GENERAL INSTALLATION

- A. Install complete raceway system as shown on drawings, including track, cover plate, device boxes, inside and outside elbows, splice plates, T's, transitions and extension rings and end caps as required.
- B. Any existing surface raceway and/or exposed cabling along the indicated pathway of the raceway to be installed shall be removed prior to the installation of the new raceway. If the existing cabling contains active service, then Contractor shall consult with the District Representative as to how best maintain the existing service before proceeding with the work.
- C. Provide and install the proper factory fabricated corners, support clips, end connectors, etc. as required.
- D. Corners and joints are to be cut neatly and finished using connector components of specified system. Where components are not available using specified system, to meet requirements of drawings, provide cleanly mitered joints, EMT and/or surface backboxes specified elsewhere herein.
- E. All installed surface raceway shall be inspected for marks, scratches, gaps between sections or improper fitting of connector parts. All such damage shall be repaired to the District's Representatives satisfaction, or the raceway shall be removed and replaced.
- F. Remove sharp corners and edges prior to installation of cable.
- G. Attachment of Raceway to Walls, Floors and Partitions:
 - 1. Attach raceway to the supporting surface with mechanical fasteners applied to building structure per the most restrictive of manufacturer's directions, Code, or these provisions.
 - 2. All surface raceway shall be installed so that its edges are parallel to the vertical or horizontal edge of the surface on which they are mounted. All surface raceway, found not to be installed in this manner, shall be removed and re-installed correctly.
 - 3. Surface raceway shall be secured at 2'-0" intervals (2 spaced screws for 2" and wider raceways) with wood screws into wooden framing or self drilling wall anchors (ITWBildex "Heavy Duty E-Z Toggle", no known equal) into sheetrock or plastic inserts with pre-assembled drive screw for concrete (ITT-HOLUB "HI-DRIVE" nail anchors, no known equal) Powder (explosive charge) driven anchors are not acceptable. The use of adhesives as the sole means for fastening to any surface is not allowed.
 - 4. Screws used in fastening surface raceway shall be no less than 3/4" in length.
 - 5. The proper support clips, as called for by the manufacturer, for securing surface raceway to walls or floors are to be used per the manufacturer's instructions.
- H. Placement of Surface Raceway:

1. As indicated on the plans, all vertical runs from surface station outlets shall drop directly from a horizontal run to the station outlet unless noted otherwise.
 - a. Raceway base and cover sections shall be minimum 24" long unless the run is shorter.
 - b. Off-set cover joints from base joints by at least 12".
 - c. Miter joints shall have gaps of less than 1/16". Caulk gaps after completion of wiring installation.

END OF SECTION

**SECTION 27 05 53
IDENTIFICATION FOR COMMUNICATIONS SYSTEMS**

PART 1 - GENERAL

1.01 SUMMARY

- A. Provide all labor, materials, tools, and equipment required for permanent intelligible labeling on, or adjacent to, all cabling, connectors, innerduct, faceplates, jacks, receptacles, controls, fuses, circuit breakers, patching jacks, and racks.
- B. This section includes minimum requirements for the following:
 - 1. Labeling Communications Cabling
 - 2. Labeling Closet Hardware
 - 3. Labeling Work Stations
 - 4. Labeling Pathways, Spaces, Grounding and Bonding.
- C. Refer to detailed plans for additional requirements.
- D. Clearly and distinctly indicate the function of the item.
- E. Coordinate with Record Drawings.

1.02 REFERENCES

- A. Usage: In accordance with Division 1.
- B. American Society for Testing and Materials (ASTM): ASTM D 709(2001) Laminated Thermosetting Materials.
- C. Electronic Industries Alliance (EIA): EIA TIA/EIA-606-A(2002) Administration Standard for Commercial Telecommunications Infrastructure (ANSI/TIA/EIA-606).
- D. Underwriters Laboratories (UL): UL 969 (1995; R 2001) Marking and Labeling Systems.

1.03 QUALITY ASSURANCE

- A. Identification and administration work specified herein shall comply with the applicable requirements of:
 - 1. ANSI/TIA/EIA – 606-A Administration Standards.
 - 2. ANSI/TIA/EIA – 569B Pathway and Spaces
 - 3. ANSI/TIA/EIA – 568-C Telecommunications Cabling Standard.
 - 4. BICSI Telecommunications Distribution Methods Manual.
 - 5. UL 969.

1.04 SUBMITTALS

- A. Conform with the requirements of Division 1 - Shop Drawings, Product Data and Samples and Section 27 05 00 - Common Work Results for Communications and the following:
 - 1. Navy Marine Corps Intranet (NMCI) Inside Cable Plant Installation Standards Final V2, June 20, 2005.

1.05 DELIVERY, STORAGE AND HANDLING

- A. Procedures: In accordance with Division 1.

1.06 SEQUENCING

- A. Not Used.

PART 2 - PRODUCTS

2.01 COMMUNICATION CABLING LABELS, INTERIOR

- A. Shall meet the legibility, defacement, exposure and adhesion requirements of UL 969.
- B. Shall be preprinted or computer printed type. Hand written labels are not acceptable.
- C. Provide vinyl substrate with a white printing area and black print. If cable jacket is white, provide cable label with printing area that is any other color than white, preferably orange or yellow – so that the labels are easily distinguishable.
- D. Shall be flexible vinyl or other substrates to apply easy and flex as cables are bent.
- E. Shall use aggressive adhesives that stay attached even to the most difficult to adhere to jacketing.
- F. Manufacturers:
 - 1. Cable Type – Silver Satin:
 - a. Brady TLS2200 labels – PTL-31-427, PTL-32-427
 - b. Brady Laser tab labels – LAT-18-361, LAT-53-361
 - c. Hubbell
 - d. Leviton
 - e. Panduit.
 - f. or equal.
 - 2. Cable Type – 4 pair UTP:
 - a. Brady TLS2200 labels – PTL-31-427,PTL-32-427
 - b. Brady Laser tab labels – LAT-18-361, LAT-53-361
 - c. Hubbell
 - d. Leviton
 - e. Panduit.
 - f. or equal.
 - 3. Cable Type – 4 pair STP:
 - a. Brady TLS2200 labels – PTL-21-427
 - b. Brady Laser tab labels – LAT-19-361
 - c. Hubbell
 - d. Leviton
 - e. Panduit.
 - f. or equal.
 - 4. Cable Type – 25 Pair Copper:
 - a. Brady TLS2200 labels – PTL-21-427
 - b. Brady Laser tab labels – LAT-19-361
 - c. Panduit.

- d. or equal.
- 5. Cable Type – 50 Pair Copper:
 - a. Brady TLS2200 labels – PTL-33-427
 - b. Panduit.
 - c. or equal.
- 6. Cable Type – 100 Pair Copper:
 - a. Brady TLS2200 labels – PTL-34-427
 - b. Brady
 - c. Panduit.
 - d. or equal.
- 7. Cable Type – 2 Strand Fiber:
 - a. Brady TLS2200 labels – PTL-19-427
 - b. Brady Laser tab labels– LAT-17-361
 - c. Panduit.
 - d. or equal.
- 8. Cable Type – 4-12 Strand Fiber:
 - a. Brady TLS2200 labels – PTL-21-427
 - b. Brady Laser tab labels – LAT-19-361
 - c. Panduit.
 - d. or equal.
- 9. Cable Type – RG-6 Coax:
 - a. Brady TLS2200 labels – PTL-31-427, PTL-32-427
 - b. Brady Laser tab labels –LAT-18-361, LAT-53-361
 - c. Panduit.
 - d. or equal.
- 10. Cable Type – RG-59 Coax:
 - a. Brady TLS2200 labels – PTL-31-427, PTL-32-427
 - b. Brady Laser tab labels – LAT-18-361, LAT-53-361
 - c. Panduit.
 - d. or equal.
- 11. Cable Bundles:
 - a. Brady TLS2200 labels – PTL-12-109
 - b. Panduit.
 - c. or equal.

2.02 COMMUNICATIONS CABLE LABELS, OUTSIDE PLANT

A. Cable Tags in Manholes, Handholes, and Vaults:

- 1. Provide tags for communications cable or wire located in manholes, handholes, and vaults.
 - a. The tags shall be polyethylene.

b. Machine printed - Do not provide handwritten letters.

2. Polyethylene Cable Tags:

- a. Provide tags of polyethylene that have an average tensile strength of 22.4 MPa (3250 pounds per square inch) 3250 pounds per square inch; and that are two millimeter (0.08 inch) 0.08 inch thick (minimum), non-corrosive non-conductive; resistive to acids, alkalis, organic solvents, and salt water; and distortion resistant to 77 degrees C 170 degrees F.
- b. Provide 1.3 mm (0.05 inch) 0.05 inch (minimum) thick black polyethylene tag holder.
- c. Provide a one-piece nylon, self-locking tie at each end of the cable tag.
- d. Ties shall have a minimum loop tensile strength of 778.75 N (175 pounds) 175 pounds. The cable tags shall have black block letters, numbers, and symbols 25 mm (one inch) one inch high on a yellow background.
- e. Letters, numbers, and symbols shall not fall off or change positions regardless of the cable tags' orientation.

3. Manufacturers:

- a. Panduit
- b. Brady
- c. or equal.

2.03 CLOSET HARDWARE LABELS

- A. Shall meet the legibility, defacement, exposure and adhesion requirements of UL 969.
- B. Shall be preprinted or computer printed type. Hand written labels are not acceptable.
- C. Where insert type labels are used provide clear plastic cover over label.
- D. Manufacturer:

1. Copper Patch Panels:

a. 4 Port Group:

- 1) Brady Laser tab labels – 2.8" x 0.375" (71.12mm x 9.52mm), LAT-43-707
- 2) Hubbell XPLPPA series
- 3) Leviton
- 4) Panduit.
- 5) or equal.

b. 6 Port Group:

- 1) Brady Laser tab labels – 3.6" x 0.375" (91.44mm x 9.52mm), LAT-44-707
- 2) Hubbell
- 3) Leviton
- 4) Panduit.
- 5) or equal.

c. Individual Port:

1) Brady:

- a) TLS2200 labels – 0.5" x 0.375" (12.70mm x 9.52mm) white, PTL-44-422
- b) Laser tab labels – 0.5" x 0.375" (12.70mm x 9.52mm) white, LAT-45-707
- c) TLS2200 labels – 0.5" x 0.375" (12.70mm x 9.52mm) clear, PTL-44-430
- d) Laser tab labels – 0.5" x 0.375" (12.70mm x 9.52mm) clear, LAT-45-712
- e) TLS2200 labels – 0.5" x 0.5" (12.70mm x 12.70mm) white, PTL-7-422
- f) Laser tab labels – 0.5" x 0.5" (12.70mm x 12.70mm) white, LAT-46-707
- g) TLS2200 labels – 0.5" x 0.5" (12.70mm x 12.70mm) clear, PTL-7-430
- h) Laser tab labels – 0.5" x 0.5" (12.70mm x 12.70mm) clear, LAT-46-712

- 2) Hubbell
- 3) Leviton
- 4) Panduit.
- 5) or equal

d. Patch Panel Name Label:

- 1) Hubbell XOLPPID Series
- 2) Brady
- 3) Leviton
- 4) Panduit
- 5) or equal.

2. Non-keystone Based Fiber Patch Panels:

- a. Hubbell XPLFOSEPAW
- b. Brady
- c. Leviton
- d. Panduit
- e. as provided with Patch Panel by the manufacturer
- f. or equal.

3. 110 Blocks:

- a. Brady Laser tab labels – 7.9" x 0.475" (200.6mm x 12.07mm), LAT-177-124
- b. Hubbell XPL110 series.
- c. Leviton
- d. Panduit.
- e. Or equal.

2.04 GROUNDING AND BONDING, PATHWAY, AND SPACE LABELS

- A. Shall meet the legibility, defacement, exposure and adhesion requirements of UL 969.
- B. Shall be preprinted or computer printed type. Hand written labels are not acceptable.
- C. Manufacturers:

1. Brady Corporation:

a. TLS2200 Labels:

- 1) PTL-20-422, Size 2.0" x 1.0" (50.80mm x 25.40mm)
- 2) PTL-22-422, Size 3.0" x 1.0" (76.20mm x 25.40mm)
- 3) PTL-37-422, Size 3.0" x 1.9" (76.20mm x 48.26mm)
- 4) PTL-23-422, Size 4.0" x 1.0" (101.60mm x 25.4mm)
- 5) PTL-38-422, Size 4.0" x 1.0" (101.60mm x 25.4mm)

b. Laser Tab Labels:

- 1) LAT-13-747, Size 1.875" x 0.833" (47.63mm x 21.16mm)
- 2) LAT-24-747, Size 1.75" x 1.0" (44.45mm x 25.40mm)
- 3) LAT-32-747, Size 3.0" x 0.9" (76.20mm x 22.86mm)
- 4) LAT-33-747, Size 2.0" x 1.437" (50.80mm x 36.50mm)
- 5) LAT-34-747, Size 3.0" x 1.437" (76.20mm x 36.50mm)

c. Continuous Tape for TLS2200:

- 1) PTL-8-422, Size 0.5" (12.70mm) white polyester
- 2) PTL-8-430, Size 0.5" (12.70mm) clear polyester
- 3) PTL-8-439, Size 0.5" (12.70mm) white vinyl
- 4) PTL-42-439, Size 1.0" (25.4mm) white vinyl
- 5) PTL-43-439, Size 1.9" (48.26mm) white vinyl

2. Panduit.

3. Or equal.

2.05 WORKSTATION LABELS

A. Shall meet the legibility, defacement, exposure and adhesion requirements of UL 969.

B. Shall be preprinted or computer printed type. Hand written labels are not acceptable.

C. Where insert type labels are used provide clear plastic cover over label.

D. Manufacturers:

1. Brady Corporation:

a. Desi-strip Inserts:

- 1) TLS2200 labels –1.9"x0.375"(48.26mmx9.52mm) white, PLT-40-412
- 2) Laser tab labels –1.9"x0.375"(48.26mmx9.52mm) white, LAT-176-124

b. Location ID:

- 1) TLS2200 labels - 1.0" x 0.375" (25.40mm x 9.52mm) white, PTL-16-422
- 2) Laser tab labels –1.0" x 0.375" (25.40mm x 9.52mm) white, LAT-47-707
- 3) TLS2200 labels- 1.0" x 0.375" (25.40mm x 9.52mm) clear, PTL-16-430
- 4) Laser tab labels –1.0" x 0.375" (25.40mm x 9.52mm) clear, LAT-8-712
- 5) TLS2200 labels- 1.0" x 0.5" (25.40mmx 12.70mm) white, PTL-17-422
- 6) Laser tab labels –1.0" x 0.5" (25.40mm x 12.70mm) white, LAT-7-707
- 7) TLS2200 labels- 1.0" x 0.5" (25.40mm x 12.70mm) clear, PTL-17-430

- 8) Laser tab labels- 1.0" x 0.5" (25.40mm x 12.70mm) clear, LAT-7-712
- 9) TLS2200 labels- 1.5" x 0.375" (38.10mm x 9.52mm) white, PTL-45-422
- 10) Laser tab labels- 1.5" x 0.375" (38.10mm x 9.52mm) white, LAT-47-707
- 11) TLS2200 labels- 1.5" x 0.375" (38.10mm x 9.52mm) clear, PTL-45-430
- 12) Laser tab labels-1.5" x 0.375" (38.10mm x 9.52mm) clear, LAT-47-712
- 13) TLS2200 labels- 1.5" x 0.5" (38.10mm x 12.70mm) white, PTL-29-422
- 14) Laser tab labels- 1.5" x 0.5" (38.10mm x 12.70mm) white, LAT-47-707
- 15) TLS2200 labels- 1.5" x 0.5" (38.10mm x 12.70mm) clear, PTL-29-430
- 16) Laser tab labels-1.5" x 0.5" (38.10mm x 12.70mm) clear, LAT-47-712

c. Outlet/Jack ID:

- 1) TLS2200 labels -0.5" x 0.375" (12.70mm x 9.52mm) white, PTL-44-422
- 2) Laser tab labels - 0.5" x 0.375" (12.70mm x 9.52mm) white, LAT-45-707
- 3) TLS2200 labels - 0.5" x 0.375" (12.70mm x 9.52mm) clear, PTL-44-430
- 4) Laser tab labels -0.5" x 0.375" (12.70mm x 9.52mm) clear, LAT-45-712
- 5) TLS2200 labels - 0.5" x 0.5" (12.70mm x 12.70mm) white, PTL-7-422
- 6) Laser tab labels- 0.5" x 0.5" (12.70mm x 12.70mm) white, LAT-46-707
- 7) TLS2200 labels - 0.5" x 0.5" (12.70mm x 12.70mm) clear, PTL-7-430
- 8) Laser tab labels - 0.5" x 0.5" (12.70mm x 12.70mm) clear, LAT-46-712

d. General Use Labels:

- 1) TLS2200 labels - 0.375" (9.52mm) cont. white, PTL-46-422
- 2) TLS2200 labels - 0.375" (9.52mm) cont. clear, PTL-46-430

2. Hubbell:

a. Location ID:

- 1) Desi-Strip Style: XPLFP10W
- 2) Adhesive:LFPA10W, XPLFPA10W,

b. Outlet/Jack ID: XPLIPA10W, XPLIPA10C

3. Leviton.

4. Panduit.

5. Or equal.

2.06 NAMEPLATES

A. Field Fabricated Nameplates:

1. Features/Function/Construction:

- a. Provide laminated plastic nameplates for each equipment enclosure, relay, switch, and device; as specified or as indicated on the drawings.
- b. Comply with ASTM D 709.
- c. Each nameplate inscription shall identify the function and, when applicable, the position.
- d. Nameplates shall be melamine plastic, 0.125 inch thick, white with black center core.

- e. Surface shall be matte finish.
- f. Corners shall be square.
- g. Accurately align lettering and engrave into the core.
- h. Minimum size of nameplates shall be one by 2.5 inches.
- i. Lettering shall be a minimum of 0.25 inch high normal block style.

PART 3 - EXECUTION

3.01 GENERAL

- A. Apply labeling to clean surfaces free of oil, dust, solvents or loose material.
- B. Apply after Project painting in area of application is complete.
- C. Apply to locations where labeling will not be damaged, covered over or in the way of the ordinary maintenance and operation of the installed communications infrastructure or system.
- D. Apply labeling right side up, parallel to major edges of surfaces to which it is applied. When no line is evident, apply parallel to floor line. Correct conditions of labeling applied out of true.
- E. Protect installed labeling from damage.
- F. Replace labeling that is defaced, illegible or peeling off of the surface to which it is applied.

3.02 IDENTIFICATION & LABELING

- A. Pathways:
 - 1. Pathways shall be marked at each endpoint and at all intermediate pull or junction boxes. In the case of partitioned pathways (i.e. innerduct) each partition shall have a unique identifier.
 - 2. Label pathways using the appropriate abbreviation and a number.
 - 3. Use adhesive type labels.
 - 4. Labels shall be affixed at the entry to all telecommunications rooms and spaces (Includes entrance facilities, communication equipment rooms, communication equipment spaces and work areas). Use adhesive type labels for all communications space labeling.
 - 5. Affix labels to entrance doors – coordinate location with District's Representative.
- B. Cables:
 - 1. Horizontal and Indoor Backbone Cables shall be marked within 12" of each endpoint or to innerduct in which the cable is installed.
 - 2. Except where installed in innerduct or conduit, all backbone fiber optic cable shall have affixed to the outer jacket, labels of a bright color that contain at least the legend "FIBER OPTIC CABLE." These labels must be affixed at separations no greater than 10 ft.

3. Within every manhole/vault/pullbox and within 4 ft of the entrance into a building every backbone cable's assigned identifier shall be affixed to either the cable's outer jacket or to innerduct in which the cable is installed.
4. Any cable installed in conduit shall be labeled at all intermediate pull or junction boxes.
5. Label cables using the appropriate circuit ID.
6. Use adhesive type labels for all communications cable labels.
7. Affix labels to cables – marking cable is not permitted.
8. Where cable is fully encased in innerduct label the outside of the innerduct with the cable label and, where the contents are fiber optic cabling, the "FIBER OPTIC CABLE" label.

C. Patch Panels:

1. Fiber patch panels shall be marked using adhesive labels indicating the range of circuits installed to it. All fiber optic cable patch panels shall be labeled with both the pair count of every fiber pair, the cable's assigned identifier, and where shown on the plans, the patch panel's assigned identifier.
2. If not shown on the Contract Documents, District Representative will provide specific circuit ID information.
3. Category rated patch panels shall be labeled with an identifier, individual ports shall be labeled to indicate circuit and identification of station plate in which the circuit terminates.

D. 110 Blocks:

1. Each cable termination position on 110 blocks shall be labeled with number designators.
 - a. All backbone copper cable termination blocks shall be labeled with both the pair count of every 5th pair and the cable's assigned identifier.
2. Where insert type labels are used install clear plastic cover over reprinted or Laser printed type label.

E. Workstations:

1. All faceplate labels shall indicate the faceplate number and the circuit ID for each cable that it houses.
2. For faceplates where insert type labels are used install clear plastic cover over preprinted or Laser printed type label.
3. For faceplates without insert type labels use adhesive type labels affix labels to faceplate – marking faceplates is not permitted.
4. Patch cords installed under the work of this Project shall be labeled at each endpoint using the appropriate circuit ID.
5. Use adhesive type labels for all communications cable labels.
6. Affix labels to cables – marking cable is not permitted.

F. Grounding and Bonding:

1. The TMGB(s) (telecommunications main ground bar) shall be labeled as such with an adhesive type label(s) affix label(s) to TMGB.
 2. The conductor connecting the TMGB (telecommunications main ground bar) to the building ground shall be labeled at each end with an affixed label in a visible location as close as practicable to the bonding point at each end of the conductor.
- G. Firestopping: Each firestopping location shall be labeled at each location where firestopping is installed, on each side of the penetrated fire barrier, within 300 mm (12 in.) of the firestopping material.

END OF SECTION

**SECTION 27 10 00
STRUCTURED CABLING, BASIC MATERIALS & METHODS**

PART 1 - GENERAL

1.01 SCOPE OF WORK

- A. This Section defines common means and methods for the work of the following Sections:
1. Section 27 11 13 – Communications Entrance Protection
 2. Section 27 11 16 – Communications Cabinets, Racks, Frames and Enclosures
 3. Section 27 11 19 – Communications Termination Blocks and Patch Panels
 4. Section 27 11 23 – Communications Cable Management
 5. Section 27 11 26 – Communications Rack Mounted Power Protection and Power Strips
 6. Section 27 13 00 – Communications Interior Backbone Cabling
 7. Section 27 14 00 – Communications Outside Plant Backbone Cabling
 8. Section 27 15 00 – Communications Horizontal Cabling

1.02 RELATED DOCUMENTS

- A. Section 27 05 00 – Common Work Results for Communications applies to the work of this Section.

1.03 REFERENCES

- A. Usage: In accordance with Division 1.
- B. In Addition to the requirements of Section 27 05 00 – Common Work Results for Communications, conform to the applicable portions of the following standards agencies:
1. American Society For Testing and Materials (ASTM): ASTM A228/A228M-02 Steel Wire, Music Spring Quality.
 2. Bellcore: TR-NWT-000253 Intermediate Reach, 1,OC3
 3. Federal Communications Commission (FCC): The Code of Federal Regulations, Title 47, Telecommunications, Chapter 1 - FCC Part 68 (1982 issue or latest revision) (47 CFR 68).
 4. Institute of Electrical and Electronic Engineers:
 - a. IEEE 383-2003 Standard for Qualifying Class 1E Electric Cables and Field Splices for Nuclear Power Generating Stations
 - b. IEEE 100-00 The Authoritative Dictionary of IEEE Standards Terms
 5. Insulated Cable Engineers Association (ICEA):
 - a. ICEA S-56-434 (1983, 5th Ed.) Polyolefin Insulated Communication Cables for Outdoor Use.
 - b. ICEA S-83-596(2001) Fiber Optic Premises Distribution Cable
 - c. ICEA S-90-661(2002) Category 3, 5 and 5e Individually Unshielded Twisted Pair Indoor Cables With or Without Overall Shield for use in General Purpose and LAN Communications Wiring Systems – Technical Requirements

6. National Electrical Manufacturers Association (NEMA): NEMA WC 63.1(2000) Twisted Pair Premise Voice and Data Communications Cables.
7. National Fire Protection Association (NFPA): NFPA 70 National Electrical Code
8. Telecommunications Industry Association/Electronic Industries Association (TIA/EIA)
 - a. TIA J-STD-607-A (2002) Commercial Building Grounding (Earthing) and Bonding Requirements for Telecommunications
 - b. ANSI/TIA-568-C.1, Commercial Building Telecommunications Cabling Standard, 2009
 - c. ANSI/TIA-568-C.2, Balanced Twisted-Pair Telecommunication Cabling and Components Standard, published 2009
 - d. ANSI/TIA-568-C.3, Optical Fiber Cabling Components Standard, published 2008, including errata issued in October, 2008.
 - e. ANSI/TIA/EIA-606-A-2002, Administration Standard for Commercial Telecommunications Infrastructure.
 - f. ANSI/ TIA/ EIA 569-B Commercial Building Standard for Telecommunications Pathways and Spaces.
 - g. TIA-569-B Commercial Building Standard for Telecommunications Pathways and Spaces.
 - h. EIA TIA/EIA-606-A(2002) Administration Standard for the Telecommunications Infrastructure (ANSI/TIA/EIA-606)
9. Underwriters Laboratories, Inc. (UL)
 - a. UL 444(2002; Bul. 2002, 2003) Communications Cables
 - b. UL 910(1998) Flame-Propagation and Smoke-Density Values for Electrical and Optical-Fiber Cables Used in Spaces Transporting Environmental Air
 - c. UL 1286(1999; R 2004) Office Furnishings
 - d. UL 1581 Reference Standard for Electrical Wires, Cables, and Flexible Cords. Oct. 2001
 - e. UL 1666(2000; R 2002) Flame Propagation Height of Electrical and Optical-Fiber Cables Installed Vertically in Shafts
 - f. UL 1863(2000; R 2004) Communications Circuit Accessories

1.04 DEFINITIONS

- A. Unless otherwise specified or indicated, electrical and electronics terms used in this specification shall be as defined in :
 1. ANSI/TIA-568-C.0, Generic Telecommunications Cabling for Customer Premises, 2009

2. ANSI/TIA-568-C.1, Commercial Building Telecommunications Cabling Standard, 2009
 3. ANSI/TIA-568-C.2, Balanced Twisted-Pair Telecommunication Cabling and Components Standard, published 2009
 4. ANSI/TIA-568-C.3, Optical Fiber Cabling Components Standard, published 2008, plus errata issued in October, 2008.
 5. EIA TIA/EIA-606-A
 6. IEEE Std 100 and
 7. in this Section.
- B. Campus Distributor (CD) - A distributor from which the campus backbone cabling emanates. (International expression for main cross-connect (MC).)
- C. Building Distributor (BDF) - A distributor in which the building backbone cables terminate and at which connections to the campus backbone cables may be made. (International expression for intermediate cross-connect (IC).)
- D. Floor Distributor (FD) - A distributor used to connect horizontal cable and cabling subsystems or equipment. (International expression for horizontal cross-connect (HC).)
- E. Telecommunications Room (TR) - An enclosed space for housing telecommunications equipment, cable, terminations, and cross-connects. The room is the recognized cross-connect between the backbone cable and the horizontal cabling.
- F. Entrance Facility (EF) (Telecommunications) An entrance to the building for both private and public network service cables (including antennae) including the entrance point at the building wall and continuing to the entrance room or space.
- G. Entrance Room (ER) (Telecommunications) - A centralized space for telecommunications equipment that serves the occupants of a building. Equipment housed therein is considered distinct from a telecommunications room because of the nature of its complexity.
- H. Open Cable - Cabling that is not run in a raceway as defined by NFPA 70. This refers to cabling that is "open" to the space in which the cable has been installed and is therefore exposed to the environmental conditions associated with that space.
- I. Open Office - A floor space division provided by furniture, moveable partitions, or other means instead of by building walls.
- J. Pathway - A physical infrastructure utilized for the placement and routing of telecommunications cable.
- 1.05 SUBMITTALS
- A. Conform with the requirements of Division 1 and Section 27 05 00 - Common Work Results for Communications.
- 1.06 DELIVERY, STORAGE AND HANDLING
- A. Comply with requirements of Division 1, Section 27 05 00 – Common Work Results for Communications and the following:

B. Shipping Conditions:

1. All cable shall be shipped on reels or manufacturer supplied "handy boxes".
2. The diameter of the drum shall be at least 13 times the diameter of the cable.
3. The reels shall be substantial and so constructed as to prevent damage during shipment and handling.
4. Secure the outer end of the cable to the reel head so as to prevent the cable from becoming loose in transit.
5. Project the inner end of the cable into a slot in the side of the reel, or into a housing on the inner slot of the drum, in such a manner and with sufficient length to make it available for testing.
6. The inner end shall be fastened so as to prevent the cable from becoming loose during installation. End seals shall be applied to each of the cables to prevent moisture from entering the cable.

C. Storage:

1. Retain factory cable protection until installation. Supplement with heavy gauge plastic sheeting if factory protective membrane is pierced prior to installation. Tape ends and seams water and dust tight.
2. The reels with cable shall be suitable for outside storage conditions when the temperature ranges from minus 40 degrees C to plus 65 degrees C, with relative humidity from 0 to 100 percent.
3. Protect cable reels from physical damage from site construction vehicles or from settling into the soil.
4. Equipment, other than cable, to be delivered and placed in storage shall be stored with protection from the weather, humidity and temperature variation, dirt and dust, or other contaminants.

1.07 SEQUENCING

- A. Not Used.

1.08 PERFORMANCE STANDARDS

A. Horizontal (Station) Copper Cabling – Permanent Link :

1. Category 5e as defined in TIA/EIA-568-C, when field tested after installation in conformance with Chapter 11 Cabling Transmission Performance and Test Requirements of TIA/EIA-568-C, with the test measurements performed using a Level III or better field tester as defined in TIA/EIA-568-C and shall meet or exceed the following:

<u>Parameter</u>	<u>Category 5E Minimum Permanent Link Standard</u>
Specified Frequency Range	1-100 MHz
Pair to Pair NEXT	32.3 dB
Power Sum NEXT	29.3 dB
Insertion Loss	21.0 dB
Pair to Pair ELFEXT	18.6 dB

Power Sum ELFEXT	15.6 dB
Return Loss	12.0 dB
Propagation Delay	498ns @ 10MHz
Delay Skew	44ns
Wire Map	T568A
Length	<295 feet

- a. Report whether tested link passes or fails
- b. Note exceptions to required Category standards. Remedy and retest.

B. Fiber Optic Cabling:

1. Optical Budget, any end to end link not to exceed the sum of the following:
 - a. Optical fiber loss.
 - b. Splice loss.
 - c. Connector loss.
2. Optical fiber loss shall be the optical fiber specified cable performance, pro-rated for total link distance.
 - a. Fiber Loss, Multimode, not to exceed:
 - 1) At 850 nanometers, 3.5 dB per Kilometer.
 - 2) At 1300 nanometers, 1.5 dB per Kilometer.
 - b. Fiber Loss, Singlemode, Outside Plant Cable, not to exceed:
 - 1) At 1310 nanometers, 0.5 dB per Kilometer.
 - 2) At 1550 nanometers, 0.5 dB per Kilometer.
 - c. Fiber Loss, Singlemode, Inside Plant Cable, not to exceed:
 - 1) At 1310 nanometers, 1.0 dB per Kilometer.
 - 2) At 1550 nanometers, 1.0 dB per Kilometer.
3. Splice Loss:
 - a. Multimode: 0.15 dB for each fusion splice
 - b. Single Mode: 0.06 dB for each fusion splice
4. Connector Loss:
 - a. Multimode: 0.75 dB for each mated pair of type SC, Ultra Polish Connector.
 - b. Single Mode
 - 1) 0.75 dB for each mated pair of type SC, Ultra Polish Connector.
 - 2) 0.30 dB for each mated pair of type SC, Angle Polished Connector.

1.09 TESTING

A. General:

1. Test and report on each intermediate cabling segment separately, including station cabling, horizontal distribution (each segment, if multiple) and telecommunications room wiring.
 2. Test each end to end cable link.
 3. Submit machine-generated documentation and raw data of all test results on Contractor-provided, and District Representative approved, forms; and in electronic format approved by the District's Representative.
 4. Provide machine-generated data on an appropriate disk media (CD-ROM CD-R format) to be transferred to the District's computers.
 - a. Where the machine-generated documentation requires use of a proprietary computer program to view the data, provide the District with 1 licensed copy of the software.
 5. Provide registered testing software used for the actual tests to the District for review of test data.
- B. Test Equipment:
1. Provide in conformance with the applicable requirements of 27 05 00 - Common Work Results for Communications.
 2. Test systems using at least one (1) each of the following test measurement devices or their functional equivalents.
 3. Test systems using at least one (1) each of the following test measurement devices or their functional equivalents:
 - a. Level IIIe field testers as defined in ANSI/TIA-1152 - Fluke, Agilent or equal.
 - 1) The tester including the appropriate interface adapter must meet the specified accuracy requirements. The accuracy requirements for the permanent link test configuration (baseline accuracy plus adapter contribution) are specified in Table 4 of ANSI/TIA-1152 (Table 4 in this TIA document also specifies the accuracy requirements for the Channel configuration).
 - 2) The RJ45 test plug shall fall within the values specified in ANSI/TIA-568-C Annex C for NEXT, FEXT and Return Loss.
 - b. The tester interface adapters must be of high quality and the cable shall not show any twisting or kinking resulting from coiling and storing of the tester interface adapters. In order to deliver optimum accuracy, preference is given to a permanent link interface adapter for the tester that can be calibrated to extend the reference plane of the Return Loss measurement to the permanent link interface. The contractor shall provide proof that the interface has been calibrated within the period recommended by the vendor. To ensure that normal handling on the job does not cause measurable Return Loss change, the adapter cord cable shall not be of twisted-pair construction.
 - c. Outside Plant Voice Cabling Plant tester - capable of detecting shorts, opens, reversals, mis-wiring and crosstwists. (Siemon STM-8, Fluke or equal).

- d. Tone Test Sets.
 - e. Optical power meter (HP, Corning Cable Systems, Fluke or equal).
 - f. Site portable communications systems (walkie-talkie, cell phone or similar).
 - g. Any other items of equipment or materials required to demonstrate conformance with the Contract Documents.
- C. Station Wiring, General:
1. Test station wire only after all pairs of station wire in a work area have been terminated at both ends, and no work of this Section or other Sections may cause physical disturbance to the wiring.
 2. Correct any and all transpositions found. Retest.
 3. If any conductor in a station wire tests either open or short, then the entire station wire is to be removed, replaced, and re-tested.
- D. Telephone: Outside Plant, Inside Riser Wire:
1. General:
 - a. A new cable shall be tested only after all wires within the cable have been terminated at both ends.
 - b. For unshielded cable, "measurements to ground" means an electrical connection to the Telecommunications Ground Bus, building steel, electrical metallic conduit or a water pipe.
 - c. The Contractor shall correct all defects possible.
 - d. If the maximum number of unrepairable defective pairs exceeds 4% of the cable's pair count, the cable shall be deemed unacceptable and shall be replaced. Replace, re-terminate and retest new cable at no additional cost to the District.
 2. Test procedures:
 - a. TEST #1 – Continuity:
 - 1) Meter set for 20 ohm full scale ohm reading. Each pair shall be shorted at one end and the loop resistance value read at the other.
 - 2) The difference between the largest and the smallest resistance reading from each pair in the cable shall be no more than 10 percent of the largest reading.
 - b. TEST #2 - Balance, Polarity and Conductor Transpositions: Upon passing Test #1, the tester at one end of cable shall ground tip side of each pair in turn. The tester at other end of cable reads resistance to building ground of same conductor.
 - c. REQUIREMENT: Reading for each tip conductor in pair of approximately one-half the loop resistance value from Test #1.

3. Test Report: Submit Test Report. Documentation shall include loop resistance regarding any opens, shorts, transpositions found, as well as corrective action taken to correct any found opens, shorts, or transpositions.

E. Fiber Optic Cabling:

1. Perform fiber optic cable testing on all installed fiber optic cabling. Submit test results. Notify District Representative in writing at least 48 hours in advance that fiber optic cable testing shall commence. Submit calibration certification for testing equipment to be used.
2. Submit test report no later than five days after the cables are tested.
3. Test and submit Power Meter attenuation assessments test results on each fiber, in each cable, and in both directions under final installation conditions. Submit with the following information:
 - a. Date of test
 - b. Name of test personnel
 - c. Fiber cable type and part number
 - d. Fiber number
 - e. TX wavelength
 - f. TX location
 - g. RX location
 - h. TX model and serial number
 - i. RX model and serial number
 - j. Attenuation in dB
4. Acceptance Tests:
 - a. Power Meter Attenuation Test:
 - 1) Perform on all fiber cabling segments.
 - 2) Method: Perform the following measured attenuation tests using the method B of ANSI/EIA/TIA-526-14A for multimode strands and ANSI/EIA/TIA-526-7 for singlemode strands. Measure the attenuation of the fiber optic network inclusive of all splices and patch points called for on the Drawings.
 - 3) Measure attenuation between all the coupling points (when applicable) using the insertion method.
 - 4) Perform a reference measurement in dBm to determine the injection power level of the stabilized source. Reference cable shall have the same core diameter as strands under test. Connect the optical source directly to the optical power level meter using 2 reference cables and a coupler.
 - 5) Connect the optical source to the strand under test using 1 of the 2 reference cables attached to the strand's terminal coupler.
 - 6) Connect the optical power level meter to the other end of the strand under test through its terminating coupler using the other reference cable.

- 7) Obtain the measured attenuation (in dB) by subtracting the reference level (dBm) from the received level (dBm).
 - a) Periodically during the acceptance tests, check and document the reference level.
 - 8) Test each fiber link for overall attenuation from end to end in both directions.
 - 9) Perform the attenuation acceptance test at the 850 nm wavelength for multi-mode and 1310 nm for single-mode.
- b. OTDR Distance and Attenuation Assessments:
- 1) Perform on all cabling segments 1000 feet or longer.
 - 2) Perform in accordance with the requirements of:
 - a) ANSI/EIA/TIA-568-C.1
 - b) ANSI/EIA/TIA-568-C.3
 - c) TIA/EIA-455-59-A
 - 3) Test and submit strip charts and/or tracer recordings on all strands in each tube in every cable in both directions. Submit with the following information:
 - a) Date of test
 - b) Name of test personnel
 - c) Test wavelength
 - d) Pulse duration(s) and scale range(s)
 - e) Index of refraction
 - f) Fiber cable type and part number
 - g) Fiber tube and/or fiber strand number
 - h) Direction of test
 - i) Overall distance
 - j) Attenuation in dB

PART 2 - PRODUCTS

2.01 COMMUNICATIONS CABLES AND RELATED

A. General:

1. Cabling shall be UL listed for the application and shall comply with EIA TIA/EIA-568-C.1, TIA/EIA-568-C.2, TIA/EIA-568-C.3 and NFPA 70.
2. Ship cable on reels and/or in boxes bearing manufacture date for UTP in accordance with ICEA S-90-661 and optical fiber cables in accordance with ICEA S-83-596 for all cable used on this project. Cabling manufactured more than 12 months prior to date of installation shall not be used.
3. Comply with applicable Code for insulation, jacket, marking and listing for applicable use.
 - a. At plenums, provide type CMP or OFNP cabling.
 - b. At risers, provide type CMR or OFNR cabling
 - c. At horizontal wiring conditions, provide type CM or OFN cabling.

4. Refer to Section 27 14 00 - Communications Outside Plant Backbone Cabling for underground cabling installation.

2.02 FIBER OPTIC CABLING, GENERAL REQUIRMENTS

A. General:

1. Fiber count per cable to comply with minimum counts indicated on the plans. Plans indicate specific cable counts providing quantities of multimode and single mode fiber strands.
2. Quantities are minimum quantities. At Contractor's option, provide a greater number. Where a greater number are provided, terminate, test, label and document all strands on fiber patch panels and/or terminal boxes as indicated as if quantity provided were called out for on the plans.
3. Where contract documents call for individual single mode and multimode cables, Contractor may substitute a hybrid cable with the same or greater strand count of each type.
4. Comply with applicable Code for insulation, jacket, marking and listing for applicable use.
 - a. Provide nonconductive optical fiber general purpose cable (OFN or OFNG), nonconductive optical fiber plenum cable (OFNP), and nonconductive optical fiber riser cable (OFNR) rated cable in accordance with NFPA 70 and UL 910.
 - b. Type OFNP or OFNR may be substituted for type OFN or OFNG and type OFNP may be substituted for type OFNR in accordance with NFPA 70.
5. Fiber media shall, at minimum, meet the following performance standards:
 - a. ANSI/EIA/TIA 568-C.1
 - b. ANSI/EIA/TIA 568-C.3
6. Fiber media shall, at minimum, meet the following construction standards:
 - a. ICEA S-87-640
 - b. ICEA S-83-596
 - c. All dielectric, unless otherwise noted.
7. The cable cordage jacket, fiber, unit, and group color shall be in accordance with EIA TIA/EIA-598-B.
 - a. Colors shall be across specified storage/installation temperature range.
 - b. Means of providing conforming colors shall not degrade performance of cable.
8. Jacket:
 - a. Free of splits, holes or blisters.
 - b. Marked and listed in conformance with National Electric Code 770
 - c. Conform with:
 - 1) UL 1666 and

- 2) NFPA 70
 - d. Heavy duty construction, Fiberglass Epoxy Rod/Kevlar strength member(s).
 - e. Each fiber to be 100% attenuation tested by the Manufacturer prior to shipping. Manufacturer's test to be affixed to shipping reel.
 - f. Cable shall be imprinted with fiber count, fiber type and aggregate length at regular intervals not to exceed 40 inches. Hybrid fiber optic cable marking shall comply with EIA TIA/EIA-598-B.
9. Performance:
- a. Temperature Sensitivity:
 - 1) Storage: -40C degrees to +70C degrees.
 - 2) Installation: -30C degrees to +70C degrees.
 - b. Variance:
 - 1) Multimode: Specified attenuation is maximum allowed over entire operating range of cable.
 - 2) Single Mode:
 - a) Average change, not more than 0.05 dB/km at 1550 -40C degrees to +70C degrees.
 - b) Maximum change not more than 0.15 dB/km at 1550 nm.
- B. Fiber count per cable to comply with minimum counts indicated on the plans. Comply with applicable Code for insulation, jacket, marking and listing for applicable use.
- C. Fiber, Multimode - General:
1. Meeting EIA/TIA 568B.3
 2. Construction:
 - a. OM3 Multimode (10 Gigabit)
 - b. Core Diameter: 50.0 +/- 3.0 per TIA/EIA-455-176.
 - c. Cladding Diameter: 125 +/- 2.0 per TIA/EIA-455-176
 - d. Numerical Aperture: 0.200 +/- 0.015 per TIA/EIA-455-177.
 - e. Core to Cladding Offset: $\leq 3.0 \mu\text{m}$.
 - f. Coating Diameter: 245 +/- 10 μm per TIA/EIA-455-173 or 163.
 - g. Core and Cladding Non-Circularity:
 - 1) Core: $\leq 5.0\%$ per TIA/EIA-455-176.
 - 2) Cladding: $\leq 2.0\%$ per TIA/EIA-455-176
 - h. Graded Index.
 - i. Effective Group Index of refraction:
 - 1) 1.49 at 850 nm
 - 2) 1.49 at 1300 nm

- j. Coating to be mechanically strippable, dual layered, UV-cured acrylate applied by the fiber manufacturer.
- 3. Each fiber to be 100% proof-tested by the manufacturer to sustain 100 kpsi load minimum per TIA/EIA-455-31
- 4. Performance:
 - a. Bandwidth:
 - 1) Laser source, per TIA/EIA-492AAAC and draft IEC 60793-2-10 for type A1a.2, ensured by DMD performance specifications for sources meeting launch conditions specified in 10 Gigabit Ethernet (IEEE 802.3ae), OIF OC-192/STM-64 VSR-4-04, and draft 10 Gigabit Fibre Channel (T11.2 10GFC).
 - a) 850 nm: > 1500 MHz at 1 km
 - b) 1300 nm: > 500 MHz at 1 km
 - 2) Overfilled Launch/LED, per TIA/EIA-455-204.
 - a) 850 nm: > 1500 MHz at 1 km
 - b) 1300 nm: > 500 MHz at 1 km
 - b. Chromatic Dispersion:
 - 1) Minimum Zero Dispersion Wavelength: 1297 nm per TIA/EIA-455-168 or 175.
 - 2) Maximum Zero Dispersion Wavelength: 1320 nm per TIA/EIA-455-168 or 175.
 - 3) Maximum Zero Dispersion Slope: 0.101 ps/nm² m per TIA/EIA-455-168 or 175.
 - c. Differential Mode Delay (DMD), ps/m, per DMD test methods TIA/EIA-455-220 and IEC 60793-1-49.
 - 1) 850 nm: < .70
 - 2) 1300 nm: < .88
 - d. Attenuation:
 - 1) 850 nm: < 2.40 dB/km maximum per TIA/EIA-455-46
 - 2) 1300 nm: < 0.70 dB/km maximum TIA/EIA-455-46
 - 3) Max attenuation point discontinuity: <0.25 dB at any design wavelength.
 - 4) Bending Attenuation induced @ 1550 nm, with 100 turns on 75mm dia mandrel:<0.50 dB
 - e. Attenuation Difference at 1380 nm, ≤ attenuation at 1300 nm + 3.0 dB/km
 - f. Water Immersion: Induced attenuation, 23 degrees C water immersion: ≤0.1 dB/km
- 5. Manufacturers:

- a. Corning Pretium 300
- b. OFS Laser Wave 300
- c. Systimax LAZRSPEED 300

D. Fiber, Singlemode - General:

1. Meeting EIA/TIA 568.
2. Construction:
 - a. Single mode.
 - b. Mode field diameter: $9.3 \pm 0.5 \mu\text{m}$ at 1310 nm (measured per Petermann II) $10.5 \pm 1.0 \mu\text{m}$ at 1550 nm
 - c. Core Diameter $8.3 \mu\text{m}$
 - d. Numerical Aperture: 0.11
 - e. Cladding Diameter: $125 \pm 1.0 \mu\text{m}$
 - f. Coating Diameter: $245 \pm 10 \mu\text{m}$
 - g. Cladding Non-Circularity: $\leq 1.0\%$
 - h. Core to Cladding Offset: $\leq 0.8 \mu\text{m}$.
 - i. Cabled Cutoff Wavelength (λ_{ccf}): $< 1260 \text{ nm}$.
 - j. OVD Process.
 - k. Coating to be mechanically strippable, dual layered, UV-cured acrylate applied by the fiber manufacturer.
3. Each fiber to be 100% proof-tested by the manufacturer to sustain 100 kpsi load minimum.
4. Performance:
 - a. Chromatic Dispersion:
 - 1) Minimum Zero Dispersion Wavelength: 1301.5 nm
 - 2) Maximum Zero Dispersion Wavelength: 1321.5 nm
 - 3) Maximum Zero Dispersion Slope: 0.092 ps/nm² per km
 - b. Dispersion:
 - 1) $\leq 3.2 \text{ ps}/(\text{nm} \cdot \text{km})$ from 1285 nm to 1330 nm
 - 2) $< 18 \text{ ps}/(\text{nm} \cdot \text{km})$ at 1550 nm
 - c. Polarization Mode Dispersion: $\# 0.5 \text{ ps}/\text{SQRT km}$
 - d. Attenuation:
 - 1) Point Discontinuity: $\leq 0.10 \text{ dB}$ at 1310 nm or 1550 nm.
 - 2) Water peak attenuation at $1383 \pm 3 \text{ nm}$: $\leq 2.1 \text{ dB}/\text{km}$
 - 3) Bending Attenuation: induced @ 1550 nm, with 100 turns on 75mm dia mandrel $< 0.10 \text{ dB}$
 - e. Water Immersion: Induced attenuation, 23°C water immersion: $\leq 0.05 \text{ dB}/\text{km}$
5. Manufacturer:
 - a. Systimax TERASPEED.
 - b. Corning
 - c. OFS

PART 3 - EXECUTION

3.01 GENERAL

- A. All system cabling and terminations be installed in accordance with the manufacturer's instructions and as shown.
- B. All necessary interconnections, services, and adjustments required for a complete and operable system shall be provided. All installation work must be done in accordance with the safety requirements set forth in the general requirements of ANSI C2 and NFPA 70.
- C. Coordinate insulation displacement (quick connect) terminal devices with wire size and type. Comply with manufacturer's recommendations. Make connections with automatic impact type tooling set to recommended force.
- D. Tin terminated shield drain wires and insulate with heat shrinkable tubing.
- E. Dress, lace or harness all wire and cable to prevent mechanical stress on electrical connections. No wire or cable shall be supported by a connection point. Provide service loops where harnesses of different classes cross, or where hinged panels are to be interconnected.
- F. Correct unacceptable wiring conditions including but not limited to:
 - 1. Deformed, brittle or cracked insulation.
 - 2. Torn or worn cable jacket.
 - 3. Excessively scored cable jackets.
 - 4. Insulation shrunken or stripped further than 1/8" away from the actual point of connection within a connector, or on a punch block.
 - 5. Ungrommeted, unbushed, or uninsulated wire or cable entries.
 - 6. Deformation or improper radius of wire or cable.

3.02 SPLICING

- A. All wire and cable shall be continuous and splice-free for the entire length of run between designated connections or terminations.
 - 1. At designated splices, maintain conductor color code across all splices.
 - a. All shielded cables shall be insulated. Do not permit shields to contact conduit, raceway, boxes, panels or equipment enclosures.
 - b. Within buildings, make splices only in designated terminal cabinets and/or on designated equipment backboards.

3.03 PULLING IN

- A. Verify that all raceway has been de-burred and properly joined, coupled, and terminated prior to installation of cables. Verify that all raceway is clear of foreign matter and substances prior to installation of wire or cable.

- B. Inspect all conduit bends to verify proper radius. Comply with Code for minimum permissible radius and maximum permissible deformation.
- C. Apply a chemically inert lubricant to all wire and cable prior to pulling in conduit. Do not subject wire and cable to tension greater than that recommended by the manufacturer. Use multi-spool rollers where cable is pulled in place around bends. Do not pull reverse bends.
- D. Provide a box loop for all wire and cable routed through junction boxes or distribution panels. Cable loops and bends shall not be bent at a radius greater than that recommended by the manufacturer.

3.04 SUPPORT

- A. Secure all wire and cable run vertically for continuous distances greater than thirty (30) feet. Secure robust non-coaxial cables with screw-flange nylon cable ties or similar devices appropriate to weight of cable. For all other cables, provide symmetrical conforming nonmetallic bushings or woven cable grips appropriate to weight of cable.
- B. Separation. Conform to the following table with respect to separation from power and radio frequency (RF) sources. Provide at least twice the listed separation at fluorescent light fixtures, ballasts and similar high intensity Electromagnetic Field sources, including but not limited to motors, transformers and copiers.

Separation of Telecommunications Cabling and Pathways from 480 V or Lower Power Lines			
Condition	Minimum Separation Distance		
	< 2kVA	2-5 kVA	> 5kVA
Unshielded power lines or electrical equipment in proximity to open or nonmetal pathways.	5 in.	12 in.	24 in.
Unshielded power lines in proximity to a grounded metal conduit pathway.	2.5 in.	6 in.	12 in.
Power lines enclosed in a grounded metal conduit (or equivalent shielding) in proximity to a grounded metal conduit pathway.	N/A	3 in.	6 in.

- C. Support: Provide support for all cabling. Conform to the restrictions of the National Electric Code and Section 27 05 29.

END OF SECTION

**SECTION 27 11 16
COMMUNICATIONS CABINETS, RACKS, FRAMES AND ENCLOSURES**

PART 1 - GENERAL

1.01 SCOPE OF WORK

- A. Communications racks and cabinets.
- B. Communications Rack Mounted Power Protection and Power Strips.

1.02 RELATED WORK IN OTHER SECTIONS

- A. Section 27 05 26 – Grounding and Bonding for Communications Systems: Bonds racks and cabinets.
- B. Section 27 05 33 – Conduits and Backboxes for Communications Systems: Signal systems raceways at communications rooms.
- C. Section 27 05 36 – Cable Trays for Communications Systems: Signal systems cable tray at communications rooms.
- D. Section 27 11 26 – Communications Rack Mounted Power Protection and Power Strips: Installation of rack mounted power strips, protection and distribution units.
- E. Section 27 13 00 – Communications Inside Backbone Cabling: Inside Backbone Terminations at communications rooms.
- F. Section 27 14 00 – Communications Outside Plant Backbone Cabling: Outside plant backbone cabling, including Entrance Protection and Termination at communications rooms.
- G. Section 27 15 00 Communications Horizontal Cabling: Rack mounted horizontal patch panels.

1.03 REFERENCES

- A. American National Standards Institute (ANSI):
 - 1. EIA-310-D (1992) Cabinets, Racks, Panels, and Associated Equipment (ANSI/EIA/310-D).
 - 2. ANSI-J-STD-607-A Commercial Building Grounding (Earthing) and Bonding Requirements for Telecommunications (ANSI/J-STD-607-A-2002)
 - 3. International Conference of Building Officials (ICBO): AC156 ICBO ES Acceptance Criteria for Seismic Qualification Testing of Nonstructural Components (Jul. 2004)
 - 4. Telecordia Technologies: Network Equipment Building System (NEBS) GR-63-CORE (Seismic Zone 4)

1.04 DELIVERY, STORAGE AND HANDLING

- A. Procedures: In accordance Section 27 10 00 – Structured Cabling, Basic Materials and Methods.

PART 2 - PRODUCTS

2.01 GENERAL

- A. Keys: Key all boxes, cabinets, enclosures, panels, controls, doors and related provided for similar usage within a system identically.

2.02 EQUIPMENT ENCLOSURE SYSTEMS

A. General:

- 1. Provide enclosure systems including, but not limited to enclosures, cabinets, cases and related panels and accessories as specified herein. Provide size and quantity as shown on drawings or scheduled.
- 2. Provide color as shown on drawings. If no color is shown on drawings, submit manufacturer's standard color chips for selection.
- 3. Provide enclosure systems conforming to the CBC, latest edition, for seismic design.
- 4. Equipment Enclosures: Each rack provided with frame angles tapped 10-32, ANSI/EIA 310-D Universal Spaced.

B. Wall Mount Swing-Out Relay Rack:

- 1. Drawing Reference: R2.
- 2. Construction:
 - a. Support Frame:
 - 1) Wall (backboard) mounted.
 - 2) Open frame - C shaped or 3 sided box construction
 - b. Swing-out EIA equipment Frame
 - 1) Rack mounting; 19 inch EIA
 - 2) Rack units: **13 units minimum, 24.5" high**
 - 3) Clear depth (equipment depth) behind rack rail face; **24 inches.**
 - 4) Swings open 90 degrees.
 - c. Latch in open and closed partitions.
 - d. Load capacity; 100 pounds, minimum.
- 3. Manufacturer:
 - a. CPI Standard Swing Gate Wall Rack 11790-725.
 - b. Equal by Middle Atlantic Products.
 - c. Equal by B-Line.
 - d. Equal by Hoffman.
 - e. Or equal.

C. Intermediate Distribution Cabinet:

- 1. Drawing Reference: R12X, where X is indicated panel opening size.
- 2. Construction: Wall mounted, three part sectional, with:
 - a. Steel, fixed mount wall terminal section

- b. Steel, center swing out section
- c. Vented steel locking front door.
- d. Fully depth-adjustable mounting rails.
- e. Combined depth of swing-away center section and fixed rear section to be **not less than 24"**.
- f. Provide with at least 1 15A half height power strip, not less than 6 receptacles.

3. Drawing Reference Schedule:

Designator	Panel Opening Size in Rack Units (1 R.U. = 1.75")
R12A	35
R12B	24
R12C	16
R12D	15
R12E	12
R12F	10
R12G	6

4. Manufacturers:

- a. Middle Atlantic Products DWR Series.
- b. Hubbell Wall Mount Cabinets
- c. B-Line E2 Series.
- d. Damac.
- e. Encore.
- f. or equal.

2.03 RACK PANELS AND ACCESSORIES

A. Rack Mounting Screws: Screws 10-32; length as required for at least 1/4" excess when fully seated; oval head with black plastic non marring cup washer or equivalent ornamental head; nickel, cadmium or black plated; Phillips, Allen Hex, Square-Tip or Torx drive. Slotted screws are not acceptable.

B. Fixed Shelf - 2 Post Rack Applications:

1. Plan Reference(s):

- a. Fixed shelf.
- b. Shelf.
- c. Construction:
- d. 18 gauge minimum cold rolled steel
- e. Powder coat finish to match rack color, unless otherwise noted
- f. Holds 25 lbs. load
- g. Mounts to front rails, supports load to rear of frame. U.O.N., center support shelves not acceptable.
- h. Solid or Perforated bottom panel to suit equipment being mounted.
- i. Not more than 1 RU in height.
- j. Manufacturers:
- k. Chatsworth Products, Inc.

I. or equal

C. Blank Panels:

1. Construction:
 - a. 16 gauge minimum cold rolled steel
 - b. Powder coat finish to match rack color, unless otherwise noted
2. Manufacturers: Middle Atlantic Products SB Series.
3. Atlas Sound S19 Series.
 - a. BGW Systems Inc. Flanged Steel Blank Panels
 - b. Dukane
 - c. Elkay
 - d. Lowell Series L3
 - e. Zero ZP112000 Series.
 - f. Hubbell
 - g. or equal

D. Vertical Lacer Strips:

1. 44RU high vertical steel strips with points for attachment of velco cable ties at least 6" o.c.
2. Manufacturer:
 - a. Middle Atlantic LACE-44LP
 - b. APW
 - c. or equal.

E. Horizontal Lacer Bars:

1. EIA 19" Width steel strips or bars suitable to provide support to large cable dressed horizontally through racks.
2. Size to suit load and mounting width.
3. Manufacturer:
 - a. Middle Atlantic LBP-1R4, LBP-1.5 and LBP-1S.
 - b. APW
 - c. or equal.

F. Seismic Hold-down Equipment Straps: Drawing Reference: None - Provide as required to secure equipment that can not be screw fastened to mounting shelves.

1. Manufacturers:
 - a. BGW Systems
 - b. Everest Electronic Equipment Lock Down Kit
 - c. Ergotron
 - d. Chatsworth Products
 - e. Middle Atlantic Products
 - f. Q-Safety, Inc.

- g. or equal.

PART 3 - EXECUTION

3.01 MOUNTING

- A. Unless otherwise noted, all floor supported equipment racks shall be bolted to the structure in accordance with the requirements of the CBC and the contractor's approved structural engineering submittal demonstrating the method to be used to conform to these requirements.
- B. Rows of identical racks shall be bolted together, in addition to being bolted to the floor and bonded to form a single electrical ground plane.
- C. Wall mounted equipment racks and cabinets shall similarly be bolted to structural members in accordance with the requirements of the CBC and the contractor's approved structural engineering submittal demonstrating the method to be used to conform to these requirements.

3.02 EQUIPMENT ENCLOSURE (RACK) AND EQUIPMENT BACKBOARD FABRICATION

- A. Combustible material, other than incidental trim of indicated equipment, is prohibited within equipment racks.
- B. Provide permanent labels for all equipment and devices.
- C. Floor racks to be bolted floor unless otherwise indicated.
- D. Access shall not require demounting or de-energizing of equipment. Install access covers, hinged panels, or pull-out drawers to insure complete access to terminals and interior components.
- E. Provide a permanent label on the front of each equipment rack including the rack designation, and the circuit breaker number and associated electrical distribution panel designation servicing same.
- F. Provide vertical wire management of cabling within the rack independent of the adjustable EIA mounting rails. Vertical wiring management provided by the contractor within the rack shall not prevent such rails from being moved as required by the Owner.
- G. Dress and support cabling at a minimum of 24 inch on center.
- H. Access shall not require demounting or de-energizing of equipment or cabling. Install access covers, hinged panels, or pull-out drawers to insure complete access to terminals and interior components.
- I. Fasten removable covers containing any wired component with a continuous hinge along one side, with associated wiring secured and dressed to provide an adequate service loop. Provide an appropriate stop locks to hold all hinged panels and drawers in a serviceable position.
- J. Provide permanent labels for all equipment and devices. Where possible, fasten such labels to the rack frame or to blank or vent panels which will remain in place when active equipment is removed for possible service.

3.03 SIGNAL GROUNDING & BONDING PROCEDURES

- A. Comply with National Electrical Code and the California Electric Code. Bond equipment racks to ground in accordance with the California Electric Code and ANSI/ EIA/ TIA 607 and Section 27 05 26.

- B. Unless otherwise noted maintain a unipoint ground scheme.
- C. Equipment enclosures shall not be permitted to touch each other unless bolted together and electrically bonded.

3.04 CONSTRUCTION WASTE MANAGEMENT

- A. Construction Waste shall be managed in accordance with provisions of Division 1.

END OF SECTION

**SECTION 27 11 19
COMMUNICATIONS TERMINATION BLOCKS AND PATCH PANELS**

PART 1 - GENERAL

1.01 SCOPE OF WORK

- A. This Section defines material standards for:
 - 1. Copper Termination Assemblies, including:
 - a. Rack and cabinet mounted copper patch panels
 - b. Backboard, rack and cabinet mounted terminal blocks
 - 2. Fiber Termination Assemblies, including:
 - a. Fiber connectors
 - b. Fiber Consolidation Panels
 - c. Rack and cabinet mounted fiber patch panels
 - d. Backboard mounted fiber terminal boxes

1.02 RELATED WORK UNDER OTHER SECTIONS

- A. Section 27 05 00 – Common Work Results for Communications
- B. Section 27 05 26 – Grounding and Bonding for Communications Systems
- C. Section 27 10 00 – Structured Cabling, Basic Materials and Methods
- D. Section 27 11 13 – Communications Entrance Protection
- E. Section 27 11 16 – Communications Cabinets, Racks, Frames and Enclosures
- F. Section 27 11 23 – Communications Cable Management
- G. Section 27 13 00 – Communications Interior Backbone Cabling
- H. Section 27 14 00 – Communications Outside Plant Backbone Cabling
- I. Section 27 15 00 – Communications Horizontal Cabling

1.03 REFERENCES

- A. ELECTRONIC INDUSTRIES ALLIANCE (EIA): EIA-310-D (1992) Cabinets, Racks, Panels, and Associated Equipment (ANSI/EIA/310-D)

1.04 SUBMITTALS

- A. Conform with the requirements of Division 1 and Section 27 05 00 - Common Work Results for Communications.

1.05 DELIVERY, STORAGE AND HANDLING

- A. Procedures: In accordance with Division 1 and Section 27 10 00 – Structured Cabling, Basic Materials and Methods.

PART 2 - PRODUCTS

2.01 PRODUCTS

A. Data Patch Panels, Keystone, Rack Mounted:

1. Drawing Reference:***C5ePP, where *** refers to port count.
2. Functions/Features:
 - a. 19" EIA rack mountable.
 - b. At least 24 ports per EIA rack unit (1.75").
 - c. Industry standard keystone openings in steel plate
 - d. arranged in rows on steel panel,
 - e. jacks on front,
 - f. terminations on rear.
 - g. Port identifier label space on front.
 - h. Fill each opening with Category 5e keystone jacks as specified herein above. Coordinate jack selection with patch panel construction to ensure that jack width behind the panel does not prevent fully loading panel.
 - i. Integral cable management bar at rear.
3. Manufacturer
 - a. Leviton QuickPort High Density Multimedia Patch Panels with Management Bar
 - b. Hubbell Xcelerator Series Panels
 - c. Molex EZ Patch
 - d. Suttle SE-2504 and SE-2504-48 Patch Panels
 - e. AMP
 - f. ADC/Krone
 - g. Ortronics
 - h. Panduit Netkey
 - i. or equal.

2.02 FIBER CABLE TERMINATION DEVICES AND RELATED

A. Fiber Optic Connectors and Related:

1. General: Connectors to comply with:
 - a. EIA/TIA-4750000-C
 - b. EIA/TIA-604-3A
2. Mechanical Splices:
 - a. Permanent application, integral matching index gel
 - b. Match connector to diameter of strand being connectorized.
 - c. Insertion Loss:
 - 1) ≤ 0.15 dB, singlemode, ≤ 0.3 dB multimode - manufacturer's rating for typical splice.
 - 2) ≤ 0.5 dB - manufacturer's guaranteed rating worst case for splice, multimode or singlemode.
 - d. Return Loss: ≤ 45 dB.
 - e. Minimum Strain Relief, Fiber retention: .75 lbs.

- f. Manufacturer:
 - 1) 3M
 - 2) AMP
 - 3) Commscope/Systimax
 - 4) Corning Cable Systems
 - 5) or equal.

3. Fusion Splice System:

a. Insertion Loss:

- 1) ≤ 0.03 dB - manufacturer's rating for typical splice – multimode
- 2) ≤ 0.06 dB - manufacturer's rating for typical splice – singlemode.

b. Manufacturer:

- 1) Corning Cable Systems Model X77 Micro Fusion Splicer
- 2) AFL Telecommunications.
- 3) or equal.

4. Connectors:

a. **LC** unless otherwise noted or scheduled.

b. Connector performance per TIA/EIA- 568.C.3 and the following.

1) Insertion Loss:

- a) Multimode: Less than or equal to 0.75 dB per mated pair
- b) Singlemode, Ultra Polish: Less than or equal to 0.75 dB per mated pair
- c) Singlemode, Angle Polish: Less than or equal to 0.30 dB per mated pair.

2) Return Loss:

- a) Singlemode, Ultra Polish, greater than or equal to 55 dB
- b) Singlemode, Angle Polish, greater than or equal to 65 dB

3) Manufacturer, Connector:

- a) Siemon
- b) Corning Cable Systems
- c) AMP
- d) Commscope/Systimax
- e) Hubbell
- f) Leviton
- g) Ortronics
- h) or equal.

B. Fiber Distribution Panels, Splice and Patch:

1. Drawing References: *** FPP or FSB, where *** refers to the fiber port count.

- a. FPP - Fiber Patch Panel
- b. FSB – Fiber Splice Box

2. Features/Functions/Performance:
 - a. FPP - 19" EIA rack mount.
 - b. FSB - Wall mount.
 - c. Suitable for housing fiber optic mechanical splices in a neat and orderly fashion.
 - d. Stores a minimum of one meter of cable without kinks or twists.
 - e. Provides individual strain relief for each splice.
 - f. Suitable for reentry, if required for future maintenance or modification, without damage to the cable or splices
 - g. All required splice organizer hardware, such as splice trays, protective glass shelves, and shield bond connectors shall be provided.
 - h. Incorporates cable tie downs and routing rings.
 - i. Quick-Release Hinges — Spring loaded quickrelease hinges enable easy removal of front and rear doors for complete access to fiber connections
 - j. Enhanced Labeling — Label virtually any port configuration hinged labels. The labels hang on the front door for improved visibility. When the door is opened, labels flip down allowing ready viewing of the label and corresponding ports
 - k. Rotating Grommets — Rotating grommets facilitate loading and retention of jumpers and fiber while minimizing microbending stress when using the sliding tray
 - l. Complete Access — Management tray has a positive stop in both front and rear working positions providing complete access for moving, adding, changing, or cleaning of fiber connections
 - m. Maximum Capacity — Enables a maximum amount of fibers to be patched or patched and spliced in a 2, 3, and 4 RMS enclosure without compromising the accessibility. This allows more efficient utilization of rack space
 - n. Top and bottom access holes located at the rear of the enclosure allow fibers to be routed between tandem enclosures without having to run fibers outside of the enclosure
 - o. LC front panel patch connector - color yellow at singlemode strands and color blue at multimode strands. Provide manufacturer's blank cover inserts at unused openings.
 - p. High Density - FPP can terminate between 18 to 36 strands per rack unit. Higher density assemblies not acceptable unless otherwise indicated on the plans.

3. Manufacturer - FPP:
 - a. Corning Cable Systems Pretium Connector Housing (PCH) with splice trays, strain relief and Closet Connector Housing (CCH) inserts as required.
 - b. Leviton Opt-X Ultra series and matching fiber Opt-X Adapter Plates and Modules as required.
 - c. Hubbell OptiChannel FCR Rack Mount Enclosures with FSP Adapter Panels as required.
 - d. Panduit
 - e. Ortronics
 - f. Commscope/Systemax
 - g. or equal.

4. Manufacturer - FSB:
 - a. Corning Wall-Mountable Connector Housing WCH-02P with WCH-SPLC-2P Splice Tray Holder.
 - b. Equal by Leviton.
 - c. Equal by Hubbell.
 - d. Equal by Panduit

- e. Equal by Ortronics
- f. Equal by Commscope/Systemax
- g. or equal.

PART 3 - EXECUTION

3.01 GENERAL

- A. Refer to Section 27 13 00 Communications Indoor Backbone Cabling for requirements for termination of Riser and Outside Plant Cabling within Communications Rooms.
- B. Refer to Section 27 10 00 – Structured Cabling, Basic Materials and Methods and Section 27 15 00 – Communications Horizontal Cabling.

END OF SECTION

**SECTION 27 11 23
COMMUNICATIONS CABLE MANAGEMENT**

PART 1 - GENERAL

1.01 SCOPE OF WORK

- A. Cable Management at Communication Room Backboards.
- B. Cable Management at rack mounted Patch Panels, including provision of cable management for cabling installed under the work of this Project as well as for District furnished patch cords at equipment racks.

1.02 RELATED WORK IN OTHER SECTIONS

- A. Section 27 05 33 – Conduits and Backboxes for Communications Systems
- B. Section 27 05 36 – Cable Trays for Communications Systems
- C. Section 27 05 39 – Surface Raceways for Communications Systems
- D. Section 27 05 53 – Identification for Communications Systems
- E. Section 27 10 00 – Structured Cabling, Basic Materials and Methods
- F. Section 27 11 16 – Communications Cabinets, Racks, Frames and Enclosures
- G. Section 27 11 19 – Communications Termination Blocks and Patch Panels
- H. Section 27 13 00 – Communications Interior Backbone Cabling
- I. Section 27 14 00 – Communications Outside Plant Backbone Cabling
- J. Section 27 15 00 – Communications Horizontal Cabling

1.03 REFERENCES

- A. American Society For Testing and Materials (ASTM): ASTM D2239-03 Standard Specification for Polyethylene (PE) Plastic Pipe (SIDR-PR) Based on Controlled Inside Diameter.
- B. Underwriters Laboratories (UL): UL 910 Test for Flame-Propagation and Smoke-Density Values for Electrical and Optical-Fiber Cables used in Spaces Transporting Environmental Air (Nov. 1998)

1.04 SUBMITTALS

- A. Conform with the requirements of Division 1 and Section 27 05 00 - Common Work Results for Communications.

1.05 DELIVERY, STORAGE AND HANDLING

- A. Procedures: In accordance with Division 1 and Section 27 10 00 – Structured Cabling, Basic Materials and Methods.

PART 2 - PRODUCTS

2.01 INNERDUCT

A. Innerduct, Single Chamber:

1. Drawing and Spec Reference(s):
 - a. ID*, Innerduct ("*" denotes cross sectional area of innerduct referenced to standard conduit trade size).
 - b. IDP*, Innerduct, Plenum ("*" denotes cross sectional area of innerduct referenced to standard conduit trade size).
2. Construction:
 - a. Selected Product Suitable for:
 - 1) underground installation in ductbank,
 - 2) plenum (IDP)
 - 3) exposed, in interior utility rooms where indicated.
 - b. High density polyethylene.
 - c. Ribbed or similar exterior construction to resist crushing surface to promote fiber cable installation.
 - d. Provides an interior chamber with a capacity equal to a trade size conduit referenced above.
3. Approvals:
 - a. ASTM D2239(1985) Polyethylene (PE) Plastic Pipe (SIDR-PR) Based on Controlled Inside Diameter.
 - b. IDP - UL Standard Test Method 2024 of UL 910.
4. Manufacturers, ID in Underground Ductbanks:
 - a. Carlon Optic-Gard/PE.
 - b. Arnco.
 - c. Vikimatic.
 - d. or equal.
5. Manufacturers, ID in Interior, Non-plenum Applications:
 - a. Carlon Optic-Gard/PVC.
 - b. Arnco.
 - c. Vikimatic.
 - d. or equal.
6. Manufacturers, IDP:
 - a. Carlon Plenum-Gard.
 - b. Arnco.
 - c. Vikimatic.
 - d. or equal.

B. Innerduct, UV Rated:

1. Drawing Reference: ID, UV Rated*, where "*" denotes cross sectional area of each chamber referenced to standard conduit trade size).
2. Approvals: ASTM D2239(1985) Polyethylene (PE) Plastic Pipe (SIDR-PR) Based on Controlled Inside Diameter.
3. Construction: Listed for UV exposure.
4. Manufacturers:
 - a. Tamaqua Plus II Series Telecom Duct.
 - b. Allwire Black AllDuct.
 - c. or equal.

C. Woven Mesh Innerduct:

1. Drawing Reference: WMID
2. Features/Functions:
 - a. Three inch wide woven mesh assembly contains at least three continuous pullable sleeves, each can accommodate a cable of at least 1" diameter.
 - b. Systems providing fewer than 3 integrally woven sleeves per WMID assembly not acceptable.
 - c. Includes color coded pull tape in each sleeve.
 - d. Pre-Lubricated for cable pulling.
 - e. Non-Hydroscopic.
 - f. 2500 Pound Tensile Strength.
 - g. 480 degree melting point.
 - h. At least 5 years prior field use including at least 25 million feet of product in use.
 - i. Provide plenum rated assembly at plenum locations as defined by the National Electric Code.
3. Manufacturers:
 - a. Maxcell/TVC 3" 3-cell in three unique colors per duct.
 - b. or equal (No known equal with identical 3 sleeves woven into a single assembly nor equal industry usage).

2.02 PATCH PANEL CABLE MANAGEMENT

A. Patch Panel Wire Management, Rack Mounted, Snap Cover:

1. Drawing References:
 - a. 1 RU Version: WMP, Wire Manager

- b. 2 RU Version: WMP, Wire Manager
2. Construction.
3. EIA 19 or 23" Rack Mount, as required.
4. Continuous flexible system of fingers and slots along top and panel, deburred to avoid snagging patch cord jacket.
5. Snap Cover.
6. Capacity:
 - a. 1 RU - accommodates at least 35 patch cords.
 - b. 2 RU - accommodates at least 70 patch cords.
7. Manufacturers – 2 RU:
 - a. Panduit WMPH2.
 - b. Siemon S110-RWM2-01
 - c. Ortronics OR-808044549
 - d. or equal.
8. Manufacturers – 1 RU: As for 2 RU, in one RU height.

2.03 BACKBOARD CABLE MANAGEMENT

- A. Fiber Management Ring, Preformed Loop:
 1. Drawing Reference: FMR
 2. Construction:
 - a. 24 inch diameter steel ring stores fiber slack using Velco fasteners at regular intervals around ring.
 - b. Screw fastens to backboard at BDF or IDF.
 3. Manufacturer:
 - a. Leviton 48900-OFR
 - b. Panduit
 - c. or equal.
- B. Wire Management Rings, Wall/Ceiling Mounted:
 1. Drawing References/Functions Features:
 - a. WMRB - Bridle Ring Type, Threaded Lag Screw.
 - b. WMRC - Closed Ring, U shaped assembly with two screw holes at ends.
 - c. WMRO - Open, Re-enterable Split Ring permitting cables to be inserted midspan, two screw holes at ends.

- d. WMP** - Steel back board with 4 inch deep min, 8 inch wide vertical wire management rings, front enterable. Provide trough at bottom of each column of WMP.
 - e. WMP**T - Narrow, steel back board with 4 inch deep min, 3 inch wide vertical wire management rings, front enterable.
2. Provide as required to support indicated cable bundle and location.
 3. Provide type WMRB at wood frame construction for cable hung from underside of ceiling, unless otherwise noted.
 4. Manufacturers:
 - a. WMRB:
 - 1) B-Line Fasteners, BR Series
 - 2) Senior Industries
 - 3) T&B
 - 4) or equal.
 - b. WMRC:
 - 1) Chatworth Products Wall Mount Closed D Ring.
 - 2) Senior Industries
 - 3) or equal.
 - c. WMRO:
 - 1) Chatworth Products Wall Mount Open Ring.
 - 2) AllenTel
 - 3) Commscope/Systemax, Inc.
 - 4) Siemon
 - 5) or equal.
 - d. WMP:
 - 1) Siemon S188-*** to match adjacent terminal blocks with S188-WD
 - 2) Ortronics OR-806003194 or OR-806003196 to match terminal blocks.
 - 3) By any manufacturer listed for 110TB under Section 27 11 19 – Communications Termination Blocks and Patch Panels
 - 4) or equal.
 - e. WMP**T:
 - 1) Siemon S110M-WM-*** to match adjacent terminal blocks
 - 2) By any manufacturer of listed for 110TB under Section 27 11 19 – Communications Termination Blocks and Patch Panels
 - 3) or equal.

PART 3 - EXECUTION

3.01 INNERDUCT INSTALLATION

- A. Schedule of Application:
 1. Underground:

- a. Provide WMID at new and existing ducts used by the work of this project in accordance with the schedules on the plans.
 - b. Place fiber cabling and 50 pair and copper telephone cabling meeting the maximum diameter requirements of the WMID manufacturer inside WMID.
 - c. Omit WMID at conduits smaller than 4".
2. At tray conditions in utility tunnel and at backboard, cable runway and tray conditions at communications closets, protect fiber cabling with ID Innerduct.
 3. At plenum tray conditions, provide IDP.
 4. At 4" and larger interior conduits, provide WMID per the schedule on the plans. Provide plenum rated WMID at plenum ceiling conditions.

3.02 GENERAL

- A. Refer to Section 27 13 00 Communications Indoor Backbone Cabling for requirements for cable routing within Communications Rooms.

END OF SECTION

**SECTION 27 11 26
COMMUNICATIONS RACK MOUNTED POWER PROTECTION AND POWER STRIPS**

PART 1 - GENERAL

1.01 SCOPE OF WORK

- A. Section includes provision of power strips at racks and cabinets installed under the work of this Project.

1.02 RELATED WORK IN OTHER SECTIONS

- A. Section 27 11 16 – Communications Cabinets, Racks, Frames and Enclosures

1.03 REFERENCES

- A. ELECTRONIC INDUSTRIES ALLIANCE (EIA): EIA-310-D(1992) Cabinets, Racks, Panels, and Associated Equipment (ANSI/EIA/310-D).

1.04 SUBMITTALS

- A. Conform with the requirements of Division 1 and Section 27 05 00 - Common Work Results for Communications.

1.05 DELIVERY, STORAGE AND HANDLING

- A. Procedures: In accordance with Division 1 and Section 27 10 00 – Structured Cabling, Basic Materials and Methods.

PART 2 - PRODUCTS

2.01 EQUIPMENT ENCLOSURE POWER, PROTECTION AND SIGNAL GROUNDING

- A. Comply with applicable Codes. Provide UL Listed devices suitable for commercial use. Provide all junction boxes, raceway, fittings, wire, supports and fastenings as required for complete installation. Contractor to coordinate plug end of selected strip with rack power receptacles installed under the work of Division 26. Unless otherwise noted, provide receptacles of NEMA 5-15R configuration.
- B. Full Height Receptacle Strip, One (1) Circuit, 15A:
 - 1. Features/Construction:
 - a. Not less than 60" Long
 - b. Not less than eleven (11) 15A receptacles
 - c. Integral circuit breaker
 - d. NEMA 5-15P plug on 6' cord.
 - e. UL Listed Assembly
 - f. Provide mounting hardware as necessary to attach to rack interior.
 - 2. Manufacturers.
 - a. Wiremold Series 7011ULBC.
 - b. Lowell ACS 1524
 - c. Geist NSVB200-101S15
 - d. Hubbell PR206

- e. Leviton
- f. Middle Atlantic
- g. Chatsworth 12848-701
- h. or equal.

C. Full Height Receptacle Strip, One (1) Circuit, 20A:

1. Features/Construction:

- a. Not less than 70" Long
- b. Not less than eleven (11) 15A receptacles
- c. Integral circuit breaker
- d. NEMA 5-20P plug on 6' cord.
- e. UL Listed Assembly
- f. Provide mounting hardware as necessary to attach to rack interior.

2. Manufacturers: Contractor to coordinate selected strip with rack power receptacles installed under the work of Division 26.

- a. Geist NSVB200-102S20
- b. Hubbell PR20820DRTL
- c. Leviton P104x series
- d. Lowell ACS-2024
- e. Middle Atlantic PD-1020C-NS
- f. Wiremold Series 7011ULBC20.
- g. Chatsworth 12848-705
- h. or equal.

D. Rackmount Power Panel, Horizontal Mount, User Aux Device Use:

1. Drawing Reference: POWER.

2. Functions/Features: Front face of panel shall provide two electrical power outlets and a switch. An indicator lamp shall show the presence of AC power when on. The front face of panel shall have a black finish. The rear face shall provide a minimum of at least four receptacles. The panel shall be racked mounted in a maximum of two rack units. The panel shall be Code approved and UL rated for this application.

3. Manufacturers:

- a. Hubbell MCCPSS19TS
- b. Leviton 4515
- c. Geist SP124-1020
- d. Or equal.

PART 3 - EXECUTION

3.01 GENERAL

A. Mounting:

- 1. Mechanically fasten strips to the rack/cabinet being served using strip or rack being served.
- 2. Mount strip so that it does not impede user access to:

- a. Vertical wire management integral to the racks.
 - b. Front and rear movement of adjustable EIA mounting rails supplied with the rack or cabinet.
 - c. Mounting of District furnished EIA rack mountable equipment within the served rack.
3. Unless otherwise noted, the strip to be mounted to derive power from electrical receptacles mounted to the cable tray above the rack. Mount strip so that the power cord reaches the provided receptacles without:
- a. Causing tension on the power cord.
 - b. Putting it in direct contact with signal cabling.
 - c. Putting it in contact with sharp edges.
 - d. Lacing it to parts intended to be movable, including, but not limited to:
 - 1) slide out drawers and shelving
 - 2) rack mounted for District furnished equipment on pullout rails
 - 3) EIA adjustable mounting rails.

END OF SECTION

**SECTION 27 13 00
COMMUNICATIONS INDOOR BACKBONE CABLING**

PART 1 - GENERAL

1.01 SCOPE OF WORK

A. Work of this Section includes:

1. Indoor Copper Backbone Cabling between Communications Rooms and communications terminal nodes other than station cabling.
2. Indoor Optical Fiber Backbone Cabling between Communications Rooms and communications terminal nodes other than station cabling.
3. Terminate fiber on patch panels as specified in Section 27 11 19.
4. Terminate copper cabling on terminal blocks as specified in Section 27 11 19.
5. For all cabling:
 - a. Test cabling to demonstrate performance to specified standards or better using test equipment and methods as specified in Section 27 10 00.
 - b. Label cables, jacks, plates and patch panels as specified in Section 27 05 53.
 - c. Document on Record Documents as described in Section 27 05 00.

B. Related work in other Sections:

1. Section 27 05 26 – Grounding and Bonding for Communications Systems
2. Section 27 05 29 – Hangers and Supports for Communications Systems
3. Section 27 05 33 – Conduits and Backboxes for Communications Systems
4. Section 27 05 36 – Cable Trays for Communications Systems
5. Section 27 05 39 – Surface Raceways for Communications Systems
6. Section 27 05 48 – Noise and Vibration Controls for Communications Systems
7. Section 27 05 53 – Identification for Communications Systems
8. Section 27 10 00 – Structured Cabling, Basic Materials and Methods
9. Section 27 11 13 – Communications Entrance Protection
10. Section 27 11 16 – Communications Cabinets, Racks, Frames and Enclosures
11. Section 27 11 19 – Communications Termination Blocks and Patch Panels
12. Section 27 11 23 – Communications Cable Management
13. Section 27 11 26 – Communications Rack Mounted Power Protection and Power Strips
14. Section 27 15 00 – Communications Horizontal Cabling

1.02 REFERENCES

- A. Refer to Section 27 10 00 – Structured Cabling, Basic Materials and Methods**

1.03 SUBMITTALS

- A. Conform with the requirements of Division 1 and Section 27 05 00 - Common Work Results for Communications.**

1.03 DELIVERY, STORAGE AND HANDLING

- A. Procedures: In accordance with Division 1 and Section 27 10 00 – Structured Cabling, Basic Materials and Methods.

PART 2 - PRODUCTS

2.01 FIBER OPTIC COMMUNICATIONS CABLING AND RELATED

- A. Fiber Optic Cable, Riser:

1. Drawing References:

- a. XX FOM-R Multimode, where XX indicates fiber count.
- b. XX FOS-R Singlemode, where XX indicates fiber count.
- c. XX FOH-R Hybrid, where XX indicates total fiber count. Ratio of Single mode to Multimode within overall count is 1:1, unless otherwise noted.

2. Refer to Section 27 10 00 – Structured Cabling, Basic Materials and Methods, including Fiber Cable Construction, General, Fiber, Multimode, General, and Fiber, Single Mode, General, as applies.

3. Application: Intra-building distribution in building risers and below building crawl space.

4. Listing: Meeting NEC OFNR, Listing by nationally recognized testing agency.

a. Construction:

- 1) Refer additionally to Fiber Cable Construction, General, elsewhere herein.
- 2) Jacket: Subject to listing and rating for vertical riser cable.
- 3) Tight Buffer construction only, "Core Lock" not required.
- 4) Otherwise as for FO*-OP, except for construction affecting listing.

b. Dimensions, not to exceed the following:

- 1) 1 to 4 Fibers:0.20"
- 2) 5 to 12 Fibers: 0.28"
- 3) 12 to 24 Fibers:0.50"
- 4) 25 to 60 Fibers: 0.80"
- 5) 61 to 108 Fibers:0.90"
- 6) 109 to 144 Fibers:1.10"

c. Performance: As for FO*-OP.

d. Manufacturer:

- 1) Any meeting requirements of Fiber Optic Cable, Outside/Inside Plant, Riser, Constrained Diameter, specified elsewhere herein.
- 2) Optical Cable Corp Ultrafox construction with LaserFox ALX Series glass for multimode strands.
- 3) Corning Cable Systems MIC.
- 4) BerkTek.
- 5) Mohawk.
- 6) Commscope/Systimax.
- 7) Belden.
- 8) or Equal.

B. Fiber Optic Cable, Outside Plant, Riser and Inside, Constrained Diameter:

1. Drawing References:

- a. XX FOM-OPR Multimode, where XX indicates fiber count.
- b. XX FOS-OPR Singlemode, where XX indicates fiber count.
- c. XX FOH-OPR Hybrid, where XX indicates total fiber count. Ratio of Single mode to Multimode within overall count is 1:1, unless otherwise noted.

2. Fiber and Application:

- a. Inter-building and intra-building distribution in building risers, below building crawl space, manholes and site conduit.
- b. Specifically suitable for continuous splice free entry into building from OSP interior past without distance limits due to construction and/or cable diameter.

3. Refer to Section 27 10 00 – Structured Cabling, Basic Materials and Methods, including Fiber Cable Construction, General, Fiber, Multimode, General, and Fiber, Single Mode, General, as applies.

4. Listing: UL OFNR. Meeting NEC OFNR

5. Construction:

- a. Suitable and approved for wet location. Meets requirements for FO*-OP where installed in those locations.
- b. As for FO*-R with not to exceed dimensional constraint. as follows:

Fiber Count	Overall Cable Diameter (in.)
2	0.18
4	0.20
6	0.22
8	0.24
10	0.26
12	0.28
14	0.28
16	0.28
18	0.28
24	0.31
30	0.35
36	0.35
48	0.41
60	0.43
72	0.47
84	0.51
96	0.55
108	0.55
120	0.59
132	0.61
144	0.63
156	0.71

6. Performance: As for FO*-R.

7. Manufacturer:
 - a. Optical Cable Corp with Laserfox ALX series glass for multimode strands.
 - b. Commscope/Systimax LazrSPEED/OptiSPEED
 - c. Commscope Uniprise Indoor/Outdoor
 - d. Corning Cable Systems FREEDM LST.
 - e. Mohawk/CDT RiserLite.
 - f. Berk-Tek UNI-Lite RD.
 - g. Belden
 - h. or equal.

PART 3 - EXECUTION

3.01 FIBER OPTIC CABLING PRACTICE

- A. Service Loop: At each Communications Room, provide at least 15 feet of fiber in excess of that required to reach the patch panel by a dressed route. Form into a storage loop and fix in place as directed by the District Representative with an FMR.
- B. Splicing:
 1. Interior: Provide mechanical splices.
 2. Exterior: Do not splice at exterior unless splicing is indicated on Plans. In such circumstances, provide fusion splices.
- C. Termination Methods:
 1. Review proposed breakout procedure with the District Representative before beginning this work.
 2. Use full cable breakout method. Display both connectorized and non-connectorized fibers entering a patch panel.
 3. Remove sheath so that no more than 4 inches of unstripped cable enters the panel.
 4. Strip back a sufficient amount of cable so that fiber strands wrap at least one full wrap, circle or figure eight, inside the panel with the connectorized ends attached to the most distant bulkhead connectors.
 5. Group together the fibers from each binder group with 0.125 inch nylon spiral wrap. (Commscope/Systimax, Panduit, Corning Cable Systems SAN-DT25-06, or equal.)
- D. Outside Plant:
 1. Obtain allowable pulling tension for underground fiber cable from the manufacturer. Use pulling equipment with tension gauges to verify that cable pulls do not exceed allowable pulling tension.
 2. Loose Tube, Gel Filled Cabling - No flow of filling when tested in accordance with FOTP-81.
- E. Loose Tube Breakout:
 1. Install breakout tubing over the full exposed length of the fiber strands.

2. Install buffer tubing on all strands, including those not being connectorized as part of this Contract.
3. Reinforce and protect the junction of the cable sheath and buffer tubing using a method approved by the District Representative before beginning this work.

3.02 COPPER BACKBONE TIE CABLE INSTALLATION AND TERMINATION

A. General: Backbone cable(s) shall be installed in conduit system unless otherwise noted.

B. Sequencing:

1. If the installation of a tie cable requires the disconnection and removal of any existing cable(s) carrying active service prior to installation.
 - a. Notify the District Representative no less than 5 working days in advance of when this work is to be performed.
2. When this work is performed, the newly installed cables must be installed, tested and passed in one 24 hour period beginning when the active service on the existing cable is interrupted.

C. Installation of Tie Cable:

1. All tie cable between terminal blocks at IDF rooms shall be continuous, unspliced runs.
2. Termination of Voice or Shared Use Tie Cable:
 - a. Cable shall be terminated on the 110 Type punch blocks system using C4 connecting blocks in the following order.
 - 1) Terminate pairs and groups in order top to bottom and then left to right according to insulation or binder color as listed below.
 - 2) "Mate" is the first wire of the pair to be terminated, "Wire" is the second.
 - b. Comply with the following table:

Group or Pair Number	Mate	Binder or Wire
1	White	Blue
2	White	Orange
3	White	Green
4	White	Brown
5	White	Slate
6	Red	Blue
7	Red	Orange
8	Red	Green
9	Red	Brown
10	Red	Slate
11	Black	Blue
12	Black	Orange
13	Black	Green
14	Black	Brown
15	Black	Slate

16	Yellow	Blue
17	Yellow	Orange
18	Yellow	Green
19	Yellow	Brown
20	Yellow	Slate
21	Violet	Blue
22	Violet	Orange
23	Violet	Green
24	Violet	Brown
25	Violet	Slate

3. Cables containing pair counts of 50 or greater shall be terminated as follows:
 - a. Columns of punch blocks stacked 2 high shall be mounted on the backboard.
 - b. Beginning at the top right of the 1st column, first the blue binder will be punched down, followed by the orange binder directly beneath it.
 - c. Binder punch will continue top to bottom, and then left to right until the entire cable has been terminated.
 - d. Thus a 50-pair cable requires two punch blocks.
 - e. Upon completing the termination of all cables within an IDF, install a clear plastic cover at each punch block.

3.03 ENTRANCE FACILITY LAYOUT

- A. General:
 1. Final backboard and cable runway design layout within the Communications Rooms shall be approved by the District Representative prior to work beginning.
 2. Reference the design basis layout in the plans and bring to the District's Representative's attention any field conditions that would prevent installation as shown on the plans. Submit for resolution in a timely manner.
- B. Layout of Cable Around Backboard:
 1. All cables shall be formed around the backboard before either rising or dropping vertically to the punch blocks on which they are to be terminated.
 2. All cables shall be organized in Wire Management Rings, Split D, Type WMRO. No tywraps or similar bindings are permitted.
- C. For Outside Plant, Flooded Cables entering the Communications Room:
 1. Transition in a splice case to non-flooded cable prior to termination on protector blocks for voice pairs, or on an unprotected 110 block for systems pairs, where such are indicated. Where systems pairs are not indicated, assume all pairs are for voice use.
 2. Position the splice case on the backboard where accessible for future service. Orient parallel to floor to prevent continuous gel flow from OSP cabling. Place on cable tray only where such placement is indicated on the plans.

END OF SECTION

**SECTION 27 15 00
COMMUNICATIONS HORIZONTAL CABLING**

PART 1 - GENERAL

1.01 SUMMARY

- A. Section includes, but is not necessarily limited to provision of:
 - 1. Horizontal Station Cabling:
 - a. Horizontal copper station cabling, meeting EIA/TIA Category 5e standards, homerun from receptacles to indicated IDF.
 - 1) Data Cables: Terminated on rack mounted patch panels, as indicated.
 - b. For all Cabling:
 - 1) Terminate on indicated termination system as specified in Section 27 11 19.
 - 2) Test cabling to demonstrate performance to specified standards or better using test equipment and methods as specified in Section 27 10 00.
 - 3) Label cables, jacks, plates and patch panels as specified in Section 27 05 53.
 - 4) Document on Record Documents as described in Section 27 05 00.
- B. Related Documents: Specification Section 27 05 00 – Common Work Results for Communications applies to this Section.
- C. Related Work in Other Sections:
 - 1. Section 27 05 29 – Hangers and Supports for Communications Systems
 - a. J-hooks and hangers for the work of this Section
 - 2. Section 27 05 33 – Conduits and Backboxes for Communications Systems
 - a. Empty raceway for the work of this Section.
 - 3. Section 27 05 36 – Cable Trays for Communications Systems
 - a. Empty tray for the work of this Section.
 - 4. Section 27 05 39 – Surface Raceways for Communications Systems
 - a. Empty raceway for the work of this Section.
 - 5. Section 27 05 53 – Identification for Communications Systems
 - a. Labeling systems and execution for the work of this Section.
 - 6. Section 27 11 19 – Communications Termination Blocks and Patch Panels
 - a. Specification for patch panels and blocks used by work of this Section
 - 7. Section 27 11 23 – Communications Cable Management
 - a. Specification for innerduct, backboard and patch cord management used by the work of this Section.

1.02 REFERENCES

- A. As listed in Section 27 10 00.

1.03 SUBMITTALS

- A. Conform with the requirements of Division 1 and Section 27 05 00 - Common Work Results for Communications.

1.04 DELIVERY, STORAGE AND HANDLING

- A. Procedures: In accordance with Division 1 and Section 27 10 00 – Structured Cabling, Basic Materials and Methods.

PART 2 - PRODUCTS

2.01 COPPER STRUCTURED CABLING SYSTEMS

- A. General: Provide horizontal cable in compliance with NFPA 70 and performance characteristics in accordance with EIA TIA/EIA-568-C.
- B. Definitions:
 - 1. Keystone Opening: A communications industry standard rectangular opening in a wall plate or patch panel having nominal dimensions of 0.58" wide and .76" high and designed to securely mount industry standard keystone jacks.
 - 2. Keystone Jacks:
 - a. A communications industry standard rectangular cable end termination with a front face having a nominal front face width of .575" and a height of .66".
 - b. The body of the jack is not significantly wider than the front face of the jack (less than 0.70"), permitting jacks to be installed adjacent to one another in industry standard multi-jack plates and patch panels.
 - c. The top of the jack features a compressible locking tab; the bottom a ridgeline.
 - d. The overall height of the jack from the bottom of the jack face to the flat top surface of the undepressed tab shall be nominally .78 inches.
 - e. When the tab is depressed, a jack can be inserted or released from the opening. Once released, the jack is locked in place by the by the ridgeline at the base and the upward force of the tab.
- C. Intervendor Compatibility:
 - 1. Keystone Jack Compatibility Test:
 - a. Any jack or panel system proposed as meeting the keystone compatibility requirements of this specification shall be able to interchangeably mount or mount in (as applies) Leviton Quickport series components.
 - b. Systems exhibiting excess play, inability to insert, inability to remove, damage to the plate or jack or occupying excessive area behind the plate opening will not be accepted.

2.02 COPPER CABLING, CATEGORY RATED DATA/VOICE

- A. General: Provide horizontal cable in compliance with NFPA 70 and performance characteristics in accordance with ANSI/TIA-568-C.

B. High Speed, TIA/TIA Category 5e Cabling:

1. Drawing Reference:** UTP5e-4, where ** denotes cable count.
2. Construction: Provide horizontal copper cable in accordance with:
 - a. EIA TIA/EIA-568-C.2,
 - b. UL 444,
 - c. NEMA WC 63.1
 - d. ICEA S-90-661
 - e. UTP (unshielded twisted pair).
 - f. 100 ohm impedance.
 - g. Four each individually twisted pair, 22 or 24 AWG conductors.
 - 1) Color Code:
 - a) Pair 1 White/Blue Blue
 - b) Pair 2 White/Orange Orange
 - c) Pair 3 White/Green Green
 - d) Pair 4 White/Brown Brown
 - h. No shield in the sheath.
 - i. Jacket:
 - 1) Thermoplastic jacket .
 - 2) Color: Blue unless otherwise indicated.
 - 3) Cable imprinted with manufacturers name or identifier, flammability rating, gauge of conductor, transmission performance rating (category designation) at regular intervals not to exceed 2 feet.
 - 4) The word "FEET" or the abbreviation "FT" shall appear after each length marking.
 - 5) Provide communications general purpose (CM or CMG), communications plenum (CMP) or communications riser (CMR) rated cabling in accordance with NFPA 70.
 - a) Type CMP and CMR may be substituted for type CM or CMG and type CMP may be substituted for type CMR in accordance with NFPA 70.
3. Certification: Warranted by the manufacturer to provide Category 5e performance when installed in accordance with applicable EIA/TIA standards and when terminated with the jacks supplied by the Contractor for this Project.
4. Performance:
 - a. Assembly electrically meets or exceeds EIA TIA/EIA-568-C.2 Category 5e performance standards and the following:
 - 1) Mutual Capacitance: 4.4 nF/100 m nom.
 - 2) DC resistance 9.38 Ohms/100 m max.
 - 3) Skew 25 ns/100 m max.
 - 4) Pair to ground unbalance: 330 pF/100 m max.
 - 5) Velocity of Propagation: 70% nom. Non-Plenum, 72% nom. Plenum

6) Input Impedance

- a) 100 ohms \pm 14% 0.772-100 MHz
- b) $100 \pm [14+15\log (F/100)]$ 100-350 MHz

- b. Meets or exceeds the following extended frequency performance parameters as documented at least the following representative frequencies:

FREQ (MHz)	SRL (dB)	RL (dB)	INSERTION LOSS (Attenuation) (dB)	PS-NEXT (dB)	NEXT (dB)	ACR (dB)	PS-ACR (dB)	ELFEXT (dB)	PS-ELFEXT (dB)
	min.	min.	max.	min.	min.	min.	min.	min.	min.
1	25.5	20	2	68.3	70.3	68.3	66.3	66.8	63.8
4	25.5	23.3	4	59.9	61.9	57.3	55.3	54.7	52.7
10	25.5	25.5	6.4	53.3	55.3	48.9	46.9	46.8	44.8
16	25.5	25.5	8.1	50.3	52.3	44.1	42.1	42.7	40.7
20	25.5	25.5	9.2	48.8	50.8	41.6	39.6	40.7	38.7
31.25	24.4	24.4	11.6	45.9	47.9	36.3	34.3	36.9	34.9
62.5	22.7	22.7	16.8	41.4	45.4	26.6	24.6	30.8	28.8
100	21.5	21.5	21.7	38.3	40.3	18.6	16.6	26.8	24.8
155	20.4	20.4	27.7	35.5	37.5	9.7	7.7	23	20
200	19.8	19.8	32.1	33.8	35.8	3.7	1.7	20.7	17.7
300	18.8	18.8	40.5	31.2	33.2	—	—	17.2	14.2
350	18.4	18.4	44.4	30.2	32.2	—	—	15.9	12.9

- 5. Environmental Minimum operating conditions meet or exceed:

- a. Installation: 0°C to +50°C
- b. Operation: -10°C to +60°C

- 6. Manufacturers:

- a. Berk-Tek LANMARK 350
- b. Belden/CDT
- c. Commscope/Systemax
- d. Commscope/Uniprise
- e. General Cable
- f. Mohawk/CDT
- g. Superior/Essex
- h. or equal

- C. Indoor/Outdoor Category 5e Cabling, Riser Rated:

- 1. Drawing Reference:** UTP5e-4OP/IDW, where ** denotes cable count.
- 2. Construction:
 - a. Fully water-blocked and has a black sunlight-resistant PVC jacket.
 - b. UL listed, NEC for riser (CMR) and outdoor (CMX) installation.
- 3. Manufacturer:
 - a. Mohawk Cable VersaLan Cat 5e (Design Basis).
 - b. Or equal.

2.02 TELECOMMUNICATIONS OUTLETS

A. Category 5e Data Jacks Performance Requirements, General:

1. Jack:

a. Construction:

- 1) High impact, flame retardant UL-rated 94V-0 thermoplastic.
- 2) The jack shall be designed with an integral locking mechanism which, upon insertion of a modular plug, provide maximum pullout strength at the plug/jack interface.
- 3) Industry standard keystone construction.

b. Performance - The jack shall meet or exceed the following standards.

- 1) TIA/EIA 568 C.1 and 568 C.2
- 2) CSA Certified
- 3) UL listed
- 4) FCC Part 68, Subpart F
- 5) Electrical - The modular jacks shall meet the following electrical performance and certification requirements.
- 6) Insulation resistance - 500 Megaohm minimum
- 7) Dielectric Withstand Voltage :
 - a) 1000 VAC RMS, 60 Hz minimum, contact to contact
 - b) 1000 VAC RMS, 60 Hz minimum to exposed conductive surface
 - c) IEEE and Cisco Power over Ethernet power dissipation standards.
- 8) Contact Resistance - 20 milliohm maximum
- 9) Current Rating - 1.5 amps at 68 degrees F (20 degrees C) per IEC Publication 512-3, Test 5b.

c. Physical - The modular jacks shall meet the following physical requirements.

- 1) Connector-insulation displacement connectors accepting 22 and 24 gauge AWG solid conductor wire.
- 2) Jack wires-square copper alloy wires with 50 micro-inch lubricated gold plating over 100 micro-inch nickel plate
- 3) Stamped crossover lead frame conductor paths
- 4) Wired to meet EIA 568C.1 and T568A Color Code
- 5) Color:
 - a) Jacks: Orange
 - b) Blank jack cover: White to match plate.
- 6) "C5e" or equivalent molded on face of jack.

d. Mechanical - The modular jacks shall meet the following mechanical requirements.

- 1) Plug insertion - minimum 750 plug insertions
- 2) Contact Force - 100 grams minimum using FCC-approved modular plugs
- 3) Plug Retention Force: 30 lb. (133 N) minimum between modular plug and jack

- 4) Temperature Range: -40 to 150 degrees F
 2. Blank Connector Modules: Features: Snaps into faceplate, fills blank openings.
 3. Manufacturers – Jacks, subject to keystone interchangeability requirement:
 - a. Leviton Gigamax Snap In Connector
 - b. Hubbell Speedgain Xcelerator
 - c. Panduit Netkey Keystone Jacks
 - d. Ortronics TechChoice Series
 - e. or equal.
 4. Manufacturers - Blank Module:
 - a. Leviton SnapIn Blank Module
 - b. Hubbell SFB
 - c. equal by listed jack manufacturers
 - d. or equal.
- B. Telecommunications Outlets, Copper Jacks, Wall Mount, Flush:
1. Drawing Reference: MMP6
 2. Assembly. Provide complete telecommunications outlet assembly, including but not limited to:
 - a. Faceplate with industry standard keystone openings
 - b. Blank connector modules at faceplate openings not filled with connector modules.
 - c. Labels and label holders.
 3. Faceplate:
 - a. Features:
 - 1) Single gang.
 - 2) Front Loading
 - 3) Openings for up to 4 keystone jack connector modules – up to 6 openings – MMP6.
 - 4) At wall mount locations calling for 4 jacks or fewer, provide with 45 degree angled openings for jacks relative to the place of the faceplate, oriented along the long edge of the plate.
 - 5) At other locations, including wall mount locations with more than 4 jacks, or inside floor boxes or above ceiling, provide with faceplates.
 - 6) Label holders with space to label the plate number and the number of each jack.
 - b. Color: To match electrical receptacles and switch plates mounted on same wall.
 4. Manufacturers - flat plates, subject to keystone interchangeability requirement.
 - a. Leviton Quickport Multimedia MOS Single Gang Wall Plates and Adapters
 - b. Hubbell InfineStation Series Faceplates and Adapters
 - c. Ortronics Keystone
 - d. Panduit Netkey.
 - e. or equal.

PART 3 - EXECUTION

3.01 SIGNAL POLARITY AND COLOR CODE CONVENTION

- A. Category 5e Station Wire, RJ45 - Per EIA/TIA-568, designation T568A

3.02 STATION CABLE INSTALLATION AND TERMINATION PROCEDURES

A. General:

1. All station cable, between the station outlets and the IDF terminal blocks, shall be continuous unspliced runs.
2. Station cable shall run loose throughout all pathways. At no time shall any station cable be secured by a tywrap, electrical tape or similar bindings.
3. At Cable Trays in Communications Rooms, bundle station cable loosely into a bundle using velcro wraps applied at 3'-0" o.c. typically. At no time permit the cables to be deformed by such cable bundling.

B. Run Lengths:

1. Station, Horizontal and IDF Links, Copper:
 - a. Horizontal Distribution runs (including vertical portions) shall not exceed 90 meters (295 feet) from station outlet to the associated communications closet.
 - b. Station cabling runs to be 3 meters (10 feet) or less.
 - c. IDF room distribution wiring not to exceed 6 meters (19.5 feet)
 - d. Alternately, total length not to exceed 100 meters (328 feet).
 - e. Report to the District Representative conditions exceeding these requirements.
2. Limit cable bends to a minimum radius of 4 times cable diameter except where otherwise noted herein.
3. Service Loop: At Communications Room: Ten foot minimum. Coil on cable backboard in FMR or equivalent.
4. Termination of wiring at the station outlet:
 - a. All data and voice station cable shall be terminated at the individual receptacle modules in accordance with EIA/TIA-568-C.
 - b. Termination of wiring at existing station outlets:
 - 1) Install in data and voice inserts in place of existing blank insert in existing faceplate.
 - 2) Install new labels and label holders.
5. Termination of station wiring at the Communications Room:
 - a. For the installation/layout of station cable within the Communications Rooms, see detail on drawings.
 - b. Fiber station cabling will similarly be terminated on rack mounted patch panels.

- c. Termination shall begin at the upper left corner of the path panel and proceed to the right continuing down, left to right until all cables are terminated.

END OF SECTION

**SECTION 28 31 00
FIRE ALARM SYSTEM**

PART 1 - GENERAL

1.01 DESCRIPTION

A. Work Included:

1. The furnishing of all labor, equipment, materials and performance of all operations in connection with the installation of the Fire Alarm System(FAS) as shown on the drawings and as herein specified.
2. The complete installation shall conform to the applicable sections of NFPA-72 A, B, C, D, E and F, Local Code Requirements Bureau and California Electrical Code.
3. All equipment, devices and cables shall be listed by Underwriters' Laboratories, Inc. and or approved by Factory Mutual for the purpose of fire alarm systems and shall be listed with the California State Fire Marshal (CSFM).
4. It is the intent of the Contract Documents to provide an installation complete in every respect. In the event that additional details or special construction is required for work indicated or specified in this Section or work specified in other Sections, it shall be the responsibility of the Contractor to provide all material and equipment which is usually furnished with such systems in order to complete the installation, whether mentioned herein or not.

1.02 DESIGN REQUIREMENTS

A. The Fire Detection System shall be responsible for continually supervising and monitoring by zone the following initiating, signaling and monitoring circuits designated as:

1. Smoke and heat detectors, including those installed under other Sections.
2. Alarm signaling circuits (alarm bells and visual alarm unit).
3. The system controls shall be Underwriters' Laboratory listed for power-limited applications per CEC 760-23.

B. The (FAS) configurations for the projects shall be as follows:

1. Horns shall be used for fire alarm signaling. Class change signaling shall be independent of the fire alarm system.

1.03 SUBMITTALS

A. All submittals shall be made in accordance with Section 01300.

B. Shop Drawings: Show equipment locations, wiring schematics, details, panel's configuration and size and a point-to-point schematic of circuits and zone schedules. Include front elevations, cabinet dimensions, type of mounting, doors, barriers, catalog number of locks, and finishes for all terminal

cabinets. Show interfaces to equipment furnished by others, identifying numbers of wires and termination requirements. Responsibility for each end of the interfaces shall be noted.

- C. Complete descriptive data indicating Underwriters' Laboratories and California State Fire Marshal listings for all system components.
- D. Complete sequence of operations of the system.
- E. Complete system wiring diagrams for components connected to the system and interfaces to existing equipment.
- F. A copy of any State or Local Fire Alarm System equipment approvals.
- G. Provide one copy of acceptance test procedures for review.
- H. Provide supplier's qualifications indicating years in business, service policies, warranty definitions and list of similar installations.
- I. Equipment, other than specified, will be considered for approval provided it meets previous Items A through H and the following is submitted in writing by the Electrical Contractor to the Architect/Engineer to allow approval at least 10 days prior to the bid opening or within 5 days after the bid award. Any substitution must be reviewed and approved by the Division of the State Architect:
 - 1. Complete lists, descriptions and drawings of materials to be used, including all (CSFM) listing numbers.
 - 2. A complete riser diagram of fire alarm system.
 - 3. A complete list of current drain requirements during normal supervisory conditions, trouble conditions and alarm system.
 - 4. Battery standby calculations showing total standby needed to meet the system requirements as specified.
 - 5. If any attempt is made to substitute that brand of equipment specified it shall be the Contractor's obligation to submit the above data and information to allow the specifying engineer time to consider the equality of the substituted items to that specified. It is the Contractor's responsibility to meet the entire intent of the Specifications. Deviations from the specified items shall be at the risk of the Contractor until the date of final acceptance by the Architect, Engineer and Owner's representative.
 - 6. Approved submittals on substitute equipment shall only allow the Contractor to proceed with installing a substituted item and shall not be considered equal until such time as the Architect, Engineer and the Owner's representative have completely accepted the substituted item. All cost for removal, relocations or replacement of a substituted item shall be at the risk of the Electrical Contractor.
- J. Fire Alarm System shall be supplied from a single source and shall be labeled with the manufacturer's name and logo on all system equipment and devices.

1.04 QUALITY ASSURANCE

- A. Shall be done by qualified Contractor holding C-10 and other licenses/certifications required by authorities having jurisdiction.
- B. Each system shall be installed by an authorized manufacturer's representative with duly authorized local representation who can, upon request, give evidence satisfactory to the Engineer that he maintains a fully equipped service organization stocking the manufacturer's standard parts and capable of furnishing, in the sole judgment of the Engineer, adequate inspections and service to the system. All signal equipment shall be supplied and installed by a licensed and bonded signal contractor holding a valid California State Electrical Contractor's license with the proper endorsements for performing work of this specification. The Fire alarm installing company shall be California State Fire and Life safety Certified.

1.05 WARRANTY

- A. The Contractor shall warrant the completed Fire Alarm System wiring and equipment to be free from inherent mechanical and electrical defects for a period of one year from the date of filing notice of completion or from the date of accepted certified test whichever is later.
- B. Trouble Calls: The Contractor shall guarantee response to a trouble call within 24 hours after the receipt of such a call.
- C. The equipment manufacturer shall make available to the Owner a Maintenance Contract Proposal to provide a minimum of two inspections and tests per year in compliance with 2010 NFPA 72 guidelines.

1.06 PERFORMANCE

- A. Furnish and install a complete Fire Alarm System as described herein and as shown on the drawings to be wired, connected, and left in first class operating condition. The system supplied under this specification shall be a microprocessor-based direct wired, multi-priority peer-to-peer networked system. The system shall utilize independently addressed, microprocessor-based smoke detectors, heat detectors, and modules as described in this specification. It shall be complete with all necessary hardware, software and memory specifically tailored for this installation. It shall be possible to permanently modify the software on site by using a plug-in programmer.

1.07 SCOPE OF WORK

- A. Initiating Devices:
 - 1. All initiating devices shall be new addressable devices as specified.
 - 2. Smoke Detectors shall be added as follows:
 - a. All public and private areas and all rooms for 100% full area coverage.
 - b. Electrical, Data, Fire Riser rooms, etc.
- B. Notifications Devices:
 - 1. Temporal 3 Horns shall be added throughout public and private spaces to achieve 15 dB above ambient as needed to meet current code requirements. All horns shall be synchronized.

2. Strobes shall be added as follows:
 - a. All Classrooms, Restrooms and all other Common Areas.
 - b. Storage areas as required by code.
 - c. Sized per ADA coverage and NFPA 72.
 - d. Combination Horn/Strobes may be used as needed.
 - e. Additional strobes shall be added in ADA rooms as needed.
 - f. Areas having more than 2 strobes in the field of view shall be synchronized.
3. Booster Power Supplies to provide the power necessary for all indicating devices. Power Supplies shall be initiated by Synchronized Signal Modules.

1.08 SEQUENCE OF OPERATIONS

- A. General Alarm Operation: Upon alarm activation of any area smoke detector, the following functions shall automatically occur:
 1. The internal audible device shall sound at the existing control panel.
 2. The LCD Display shall indicate all applicable information associated with the alarm condition including zone, device type, device location and time/date.
 3. All system activity/events shall be documented on the system printer.
 4. The following notification signals and actions shall occur simultaneously:
 - a. A signal shall be sounded. The signal shall be a Temporal 3 tone.
 - b. Activate visual strobes. The visual strobe shall stop operating when the "Alarm Silence" is pressed.
 - c. Transmit signal to the central station with point identification.
- B. Supervisory Operation: Upon supervisory activation of any sprinkler valve supervisory switch, the following functions shall automatically occur:
 1. The internal audible device shall sound at the existing control panel.
 2. The LCD display shall indicate all applicable information associated with the supervisory condition including; zone, device type, device location and time/date.
 3. All system activity/events shall be documented on the system printer.
- C. Trouble Operation: Upon activation of a trouble condition or signal from any device on the system, the following functions shall automatically occur:
 1. The internal audible device shall sound at the existing control panel.
 2. The LCD keypad display shall indicate all applicable information associated with the trouble condition including; zone, device type, device location and time/date.

3. All system activity/events shall be documented on the system printer.
4. Transmit signal to the central station with point identification.

1.09 SYSTEM DESIGN PARAMETERS

- A. Standby Power: The standby power supply shall be an electrical battery with capacity to operate the system under maximum supervisory load for twenty four (24) hours and capable of operating the system for five (5) minutes of evacuation alarm on all devices, operating at maximum load. The system shall include a charging circuit to automatically maintain the electrical charge of the battery. The system shall automatically adjust the charging of the battery to compensate for temperature.
- B. Voltage Drop: The point-to-point Ohm's Law voltage drop calculations of all alarm system circuits shall not exceed 10%.
- C. Spare Capacity: The system shall be engineered to accommodate 20% spare capacity on each individual loop, and 20% spare on system power supplies.
- D. Circuiting Guidelines:
 1. Initiating Device Circuits: Where necessary, conventional initiating device circuits (i.e. water flow switches, valve supervisory switches, fire pump functions, etc.) shall be Class B (Style "A" or "B").
 2. Notification Appliance Circuits: All notification appliance circuits shall be Class B (Style "Y"). The notification circuits shall be power limited. Non-power limited circuits are not acceptable.
 3. Signaling Line Circuits: Addressable Analog Devices
 - a. The signaling line circuit connecting to addressable/analog devices including, detectors, monitor modules, control modules, isolation modules, intrusion detection modules and notification circuit modules shall be Class B (style 4).
 - b. Each addressable analog loop shall be circuited so device loading is not to exceed 80% of loop capacity in order to leave for space for future devices.
 4. Signaling Line Circuits: Data & Audio for FACP & Annunciator Network; The signaling line circuit connecting network panel/nodes, annunciators, command centers, shall be Class A (style 7). The media shall be copper except where fiber optic cable is specified on the drawings.

PART 2 – PRODUCTS

2.01 EXISTING FIRE ALARM SYSTEM

- A. Compatibility with Existing Equipment: When modifying an existing building fire alarm system, the new components shall operate as an extension of the existing fire alarm system.

2.02 EXISTING SYSTEM: MANUFACTURER

- A. Edwards Systems Technology, Inc. (EST).

2.03 GENERAL

- A. All equipment and components shall be the manufacturer's current model. The materials, appliances, equipment and devices shall be tested and listed by a nationally recognized approval agency for use as part of a protected premises (fire alarm) system.
- B. The contractor shall provide, from the acceptable manufacturer's current product lines, equipment and components, which comply, with the requirements of these specifications. Equipment or components, which do not provide the performance and features, required by these specifications are not acceptable, regardless of manufacturer.
- C. All System components shall be the cataloged products of a single supplier. All products shall be UL listed by the manufacturer for their intended purpose.
- D. All control panel assemblies and connected field appliances shall be both designed and manufactured by the same company, and shall be tested and cross-listed as to ensure that a fully functioning system is designed and installed.

2.04 EXISTING FIRE ALARM CONTROL PANEL

- A. EST-3.

2.05 INTELLIGENT ADDRESSABLE DETECTORS

- A. Each remote device shall have a microprocessor with non-volatile memory to support its functionality and serviceability. Each device shall store as required for its functionality the following data: Device serial number, device address, device type, personality code, date of manufacture, hours in use, time and date of last alarm, amount of environmental compensation left/used, last maintenance date, job/project number, current detector sensitivity values, diagnostic information (trouble codes) and algorithms required to process sensor data and perform communications with the loop controller. Intelligent addressable detectors shall be the type designed to be used with the fire panel specified.

2.06 NOTIFICATION APPLIANCES

When Wheelock numbers are listed to establish quality standard, the words "or equal" are to be assumed.

- A. General:
 - 1. All appliances shall be UL Listed for Fire Protective Service.
 - 2. All strobe appliances or combination appliances with strobes shall be capable of providing the "Equivalent Facilitation" which is allowed under the Americans with Disabilities Act accessibility guidelines (ADA (AG)), and shall be UL 1971.
 - 3. Any appliances, which do not meet the above requirements, and are submitted, for use must show written proof of their compatibility for the purposes intended. Such proof shall be in the form of documentation from all manufacturers which clearly states that their equipment (as submitted) are 100% compatible with each other for the purposes intended.
 - 4. All wall mounted strobes and horns shall use approved back boxes.

5. See Fire Alarm Equipment Schedule.

2.07 ACCESSORY EQUIPMENT

A. Remote Booster Power Supplies:

1. Unit shall be a self contained with 24 VDC power supply and batteries housed in its own locked enclosure. Keys provided shall be identical to the keys provided for all other fire alarm equipment provided.
2. Power supply shall be available in both 10 Amp or 6.5 Amp models and 110 VAC or 220 VAC.
3. On board LED indicators for each resident NAC, battery supervision, ground fault and AC power.
4. The power supply shall provide four (4) independent 3 Amp NACs. Each circuit can be configurable as an auxiliary output.
5. Configurable for any one of Three Signaling Rates: 120SPM; 3-3-3 temporal; or, continuous.
6. Two independent and configurable inputs switch selectable to allow correlation of the two (2) inputs and the four (4) outputs.
7. The unit shall be compatible with SIGA-CC1S for synchronization of multiple power supplies without inter-connect wiring.
8. Brackets shall be provided inside the enclosure to allow mounting the signaling modules. All signaling modules shall be listed to be located inside the booster power supply enclosure.
9. A selectable dip switch shall enable built in synchronization for horns and strobes which may be used to synchronize downstream devices, as well as other boosters and their connected devices.

2.08 CONDUCTORS

- A. The requirement of this section apply to all system conductors, including all signaling line, initiating device, notification appliance, auxiliary function, remote signaling, AC and DC power and grounding/shield drain circuits, and any other wiring installed by the Contractor pursuant to the requirements of these Specifications.
- B. All circuits shall be rated power limited in accordance with NEC Article 760.
- C. Installed in conduit or enclosed raceway.
- D. All new system conductors shall be of the type(s) specified herein.
- E. All initiating circuit, signaling line circuit, AC power conductors, shield drain conductors and grounding conductors, shall be solid copper, stranded or bunch tinned (bonded) stranded copper.

- F. All signaling line circuits, including all addressable initiating device circuits shall be 18 AWG minimum multi-conductor jacketed twisted cables or twisted shielded or as per manufacturer's requirements.
- G. All non-addressable initiating device circuits, 24 VDC auxiliary function circuits shall be 18 AWG minimum or per manufacturer's requirements.
- H. All notification appliance circuit conductors shall be stranded copper or bunch tinned (bonded) stranded copper. Where stranded conductors are utilized, a maximum of 7 strands shall be permitted for No. 16 and No. 18 conductors, and a maximum of 19 strands shall be permitted for No. 14 and larger conductors.
- I. All audible notification appliance circuits shall be 14 AWG minimum twisted pairs or twisted pairs shielded or per manufacturer's requirements. All visual notification appliance circuits shall be 14 AWG minimum or twisted pairs or twisted shielded pairs or per manufacturer's requirements
- J. Alarm signaling circuits (alarm horns and visual alarm unit) shall be stranded wire, West Penn AQ246 or equal (4#14 stranded).
- K. Smoke Detection (underground) cable shall be West Penn AQ226 or equal (2#14 stranded).
- L. Splices; No splices shall be installed in conduit, Christy boxes or any inaccessible place. All splices shall be made on terminal blocks specifically designed for that purpose in terminal cabinets or locations as specifically approved by the Engineer.
- M. All underground conduit runs shall only use stranded type wires.
- N. Terminal Barrier Strips; Cinch 142 series barrier strips (minimum 6 points) for Fire Alarm system. Provide minimum two (2) space separation points between types of system cables. Strips shall include provisions for up to four (4) spare termination points. Ensure that system circuits loops are located on adjacent termination points on the barrier strip.
- O. Wire terminators to devices and on terminal barrier strips shall be with "spade" type terminal connections (Thomas and Betts Sta-Kon or Engineer approved equivalent). Contractor shall use an approved Thomas and Betts Sta-Kon or equal lugging tool.
- P. All cables shall be labeled with Panduit Label, size MP-150c thru MP-350. The size will depend on the amount of information needed on each label. All labels shall contain information as to the source and the destination of the wire including the location and terminal can numbers.

2.09 CONDUIT RACEWAY

- A. All systems and system components listed to UL864 Control Units for Fire Protective Signaling Systems maybe installed within a common conduit raceway system, in accordance with the manufacture's recommendations. System(s) or system components not listed to the UL864 standard shall utilize a separate conduit raceway system for each of the sub-systems.
- B. The requirements of this section apply to all system conduits, raceways, electrical enclosures, junction boxes, pull boxes and device back boxes.
- C. All system conduits shall be of the sizes and types specified.

- D. All system conduits shall be EMT, 3/4 -inch minimum, except for flexible metallic conduit used for whips to devices only, maximum length 6 feet, 3/4-inch diameter, minimum.
- E. All system conduits, which are installed in areas, which may be subject to physical damage or weather, shall be IMC or rigid steel, 3/4 -inch minimum.
- F. Conduits shall be sized according to the conductors contained therein. Cross sectional area percentage fill for system conduits shall not exceed 40%.
- G. Existing conduit raceway system may be re-used where possible.
- H. All fire alarm conduit systems shall be routed and installed to minimize the potential for physical, mechanical or by fire damage, and so as not to interfere with existing building systems, facilities or equipment, and to facilitate service and minimize maintenance.
- I. All conduits, except flexible conduit whips to devices, shall be solidly attached to building structural members, ceiling slabs or permanent walls. Conduits shall not be attached to existing conduit, duct work, cable trays, other ceiling equipment, drop ceiling hangers/grids or partition walls, except where necessary to connect to initiating, notification, or auxiliary function devices.
- J. All system conduits, junction boxes, pull boxes, terminal cabinets, electrical enclosures and device back boxes shall be readily accessible for inspection, testing, service and maintenance.
- K. All penetration of floor slabs and firewalls shall be sleeved (1" conduit minimum) fire stopped in accordance with all local fire codes.
- L. All junction box covers shall be painted red.

PART 3 – EXECUTION

3.01 INSTALLATION CONDITIONS

- A. Prior to commencing work that affects the existing Fire Alarm System, the contractor is required to pre-test existing system with Mt. Diablo USD Electronics Personnel to confirm operability of the system. Failure to confirm operability of the existing system signifies the contractor's acceptance of a fully operating system.
- B. All equipment and components shall be installed in strict compliance with each manufacturer's recommendations. Consult the manufacturer's installation manuals for all wiring diagrams, schematics, physical equipment sizes, etc. before beginning system installation.
- C. The entire system shall be installed in a workmanlike manner, in accordance with approved manufacturer's wiring diagram.
- D. Existing systems must be maintained in operable condition during the course of construction until the new system is tested and certified.

3.02 REQUIREMENTS

- A. All new audio/visual devices shall be mounted at a minimum of 80 inches and no more than 96 inches above the finished floor, as measured on strobe center. Devices shall be mounted no less than 6 inches from the ceiling.

- B. No area smoke detectors shall be mounted within 36 inches of any HVAC supply, return air register or lighting fixture.
- C. No area smoke or heat detector shall be mounted within 12 inches of any wall.
- D. Reprogram the fire alarm control panel for additional devices.
- E. All fire alarm devices shall be accessible for periodic maintenance. Should a device location indicated on the Contract Drawings not meet this requirement, it shall be the responsibility of the installing contractor to bring it, in writing, to the attention of the Project Engineer. Failure to bring such issues to the attention of the Project Engineer shall be the exclusive liability of the installing Electrical Contractor.
- F. All addressable modules shall be mounted within 36 inches of the monitored or controlled point of termination. This shall include, but is not necessarily limited to, fan shutdown, elevator recall, shunt trip, sprinkler status points, or door release. Label all addressable modules as to their function.
- G. All wiring shall be color-coded throughout, to California Electrical Code standards.
- H. Power-limited/Non-power-limited NEC wiring standards SHALL BE OBSERVED.
- I. Auxiliary relays shall be appropriately labeled to indicate "FIRE ALARM SYSTEM" and their specific function (i.e. FAN S-1 SHUTDOWN).

3.03 TEST & INSPECTION

- A. All fire alarm testing shall be in accordance with California Fire Alarm Code, NFPA 72 - 2010, Chapter 7.
- B. The system shall be pre-tested and documented prior to the final inspection by the inspector of record. The owner shall be notified of the pretest 48 hours in advance and shall witness this test if desired.
- C. The pre-test shall include the following:
 - 1. All intelligent analog addressable devices shall be tested for current address, sensitivity, and user defined message.
 - 2. All wiring shall be tested for continuity, shorts, and grounds before the system is activated.
 - 3. Proper operation and execution of all its sequences.
- D. Complete the NFPA 72 Record of Completion, testing all devices and appliances. Provide a copy to the Owner, Architect, Local Fire Authority and DSA. In the event the system does not operate properly, the test may be terminated. Corrections shall be made and the testing procedure shall be repeated until it is acceptable to the Owner, his representatives and the fire inspector. If the Fire Marshall is required to be present during testing, it shall be the contractor's responsibility to notify the fire department having jurisdiction.

END OF SECTION

**SECTION 31 00 00
EARTHWORK**

PART 1 – GENERAL

1.01 SECTION INCLUDES

- A. Excavation and Grading for Concrete Work.
- B. Excavation and Grading for Asphalt Concrete Paving.

1.02 RELATED SECTIONS

- A. Section 00 70 00: General Conditions.
- B. Section 32 12 16: Asphalt Paving.
- C. Section 32 13 13: Concrete Paving.
- D. Division 22: Plumbing.
- E. Division 33: Utilities.

1.03 REFERENCE STANDARDS

- A. American Society for Testing and Materials (ASTM):
 - 1. ASTM D1557-09 Standard Test Method for Laboratory Compaction Characteristics of Soil Using Modified Effort.

1.04 QUALITY ASSURANCE

- A. Perform all necessary compaction and soils preparation to obtain suitable subgrade as required by Testing Lab.
- B. Contractor must obtain District digging permit prior to commencement of any digging or excavation.

1.05 JOB CONDITIONS

- A. Existing conditions: Contractor to record existing conditions of adjacent areas prior to commencing work and report any discrepancies or conflicts with contract work.
- B. Prior to commencement of any excavations, contract Underground Service Alert (USA).
- C. Contractor to locate all existing utilities and provide protection as required.
- D. Maintain benchmarks, monuments and survey control references.
- E. Protection of Persons and Property:
 - 1. Provide dust control during all grading operations.

2. Protect all existing facilities to remain.
3. Protect Occupants from area of work by providing barricades.
4. Protect graded areas from erosion and water damage.

PART 2 – PRODUCTS

2.01 MATERIALS

- A. Fill required to establish grades for walkways shall be Class two aggregate, conforming to Section 26 of State Specifications.
- B. Native soil approved by Testing Lab may be used for fills below aggregate base indicated on drawings.

PART 3 – EXECUTION

3.01 LAYOUT

- A. All Staking and Layout Work required for work included under this section shall be the responsibility of the Contractor. He shall establish any and all reference points, lay out his work, and be responsible for all lines, elevations, measurements and other grading operations.
 1. Layout and Preparation: Prior to the beginning of any grading, excavation or trenching operations, layout all work, establish grades, locate existing underground utilities, set necessary markers and stakes, set up necessary barricades and protection facilities as outlined under Division 1, and be responsible for their correctness and adequacy.

3.02 SITE PREPARATION

- A. General: Clear and prepare the site for new walkways, ramps to the limits indicated on the drawings.
 1. All debris and materials from the cleaning operations shall become the Contractor's property and shall be removed from the site.
- B. Site Clearing: All existing, rubbish, loose and/or saturated materials, shall be removed and disposed of so as to leave areas that have been disturbed with a neat and finished appearance, free from unsightly debris.

3.03 EXCAVATIONS

- A. Excavate for all work below grade to dimensions and elevations indicated or deeper if required to obtain firm bearing.
- B. Excess excavations shall be restored to the proper elevations by the placement of additional earth and recompact to 95%.
- C. Dewatering Site:
 1. Any water which accumulates in excavations shall be drained promptly, by appropriate

means.

2. Grading is to be controlled in the vicinity of buildings and other structures so that the surface of the ground will be properly sloped to prevent water from running into excavated areas or creating adverse drainage conditions.

3.04 GRADING

- A. General: Uniformly grade areas within specified limits including adjacent transitions. Smooth finished surfaces within specified tolerances, compact with uniform levels or slopes between points indicated.
- B. Grade areas adjacent to buildings to provide positive drainage away from buildings.

3.05 COMPACTION

- A. General: Control soil compaction to provide minimum percentages of density specified for each classification as determined by Testing Lab.
- B. Percentages of Maximum Density Requirements: Compact to the percentages of maximum density, determined in accordance with ASTM D1557.
 1. Structures, Building Slabs, Steps and Pavements: Compact top 12 inches of subgrade and each layer of fill material at 95 percent maximum density.
 2. Landscape Areas: Compact top 6 inches of subgrade and each layer of fill material at 90 percent maximum density.
 3. Walkways: Compact top 6 inches of subgrade and each layer of fill material at 90 percent maximum density.
- C. Moisture Control, General Testing Lab: to be present during compaction operations. Contractors to coordinate scheduling of inspection in a minimum of 72 hours in advance.
 1. Where soil material must be moisture conditioned before compaction, uniformly apply water to surface of subgrade or layer of soil material. Prevent free water from appearing on surface during or subsequent to compaction.
 2. Where soil condition are too moist to provide adequate compaction, the Contractor is responsible for drying soils through aeration, mixing or import.

END OF SECTION

**SECTION 31 23 00
EXCAVATION AND FILL**

PART 1 - GENERAL

1.01 SECTION INCLUDES

- A. Description of requirements for materials, equipment and services necessary to complete trenching, excavation, backfilling and compaction as shown and specified for all underground utilities, related structures, and thrust blocks.
 - 1. Utilities companies' requirements where applicable will take precedence over these specifications for conduit placement only, all bedding, backfill and compaction must be per these contract specifications.

1.02 RELATED SECTIONS

- A. Division 0: Bidding and Contract Requirements
- B. Division 1: General Requirements
- C. Division 22: Mechanical
- D. Division 26: Electrical

1.03 QUALITY ASSURANCE

- A. Requirements of Regulatory Agencies:
 - 1. Safety Regulations: Work shall comply with all Federal, state and municipal regulations regarding safety, including the requirements of the following:
 - a. William-Steiger Occupational Safety & Health Act of 1970.
 - b. All trenching work shall conform to Trench Construction Safety Orders of California State Industrial Accident Commission.
- B. References and Standards:
 - 1. American Society for Testing and Materials (ASTM):
 - a. D1557-09- Standard Test Methods for Laboratory Compaction Characteristics of Soil Using Modified Effort.
- C. Observations and Inspections: The District's Geotechnical Engineering Consultant will observe and respective utilities agencies' representative will inspect utilities trenching, excavation, backfilling and compaction as appropriate. Contractor shall appropriately schedule all inspections prior to commencing trenching and backfilling operations with the Districts Construction Manger or Low Voltage Consultant. All installations are subject to satisfactory installation and inspection by the appropriate agency.

- D. Testing: Refer to Section 01 45 29:
 - 1. Backfill material compaction and other tests will be performed as shown in the plans and specifications, District's Geotechnical Engineering Consultant, and utilities agencies' requirements.
- E. Submittals: Refer to General Conditions Section 01 33 00.
 - 1. Submit on all non native backfill materials required for the execution of the work in this Section.

1.04 JOB CONDITIONS

- A. Existing conditions: Contractor to record existing conditions of adjacent areas prior to commencing work and report any discrepancies or conflicts in the contract work.
- B. Prior to commencement of any excavations, contact Underground Service Alert (USA).
- C. Contractor to locate all existing utilities and provide protection as required.
- D. Maintain benchmarks, monuments and survey control references.
- E. Protection of Persons and Property:
 - 1. Provide dust control during all excavation and backfill operations.
 - 2. Protect all existing facilities to remain.
 - 3. Protect occupants from area of work by providing barricades.
 - 4. Protect excavations from erosion and water damages.

PART 2 – PRODUCTS

2.01 MATERIALS

- A. Pipe bedding backfill material (initial backfill) shall be washed sand material graded such that 100% passes the No. 4 sieve and not more than 5% passes the No. 200 sieve, and judged suitable by the District's Geotechnical Engineering Consultant.
 - 1. Pipe bedding and backfill material used in trenches containing utilities owned by utility companies shall meet all requirements of that utility company.
- B. Trench backfill material for use above the bedding and initial backfill materials in a trench shall be native or imported material which is free of highly plastic clays, organic materials, debris or other deleterious materials. The material shall be predominately granular with no rocks or lumps larger than 3 inches in maximum dimension, and have a Plasticity Index (ASTM D4318-05) of 15 or less. All backfill materials shall be pre-approved by the District's Geotechnical Engineering Consultant.

PART 3 – EXECUTION

3.01 TRENCHING

- A. Make all trenches open vertical or sloped construction, as recommended by the manufacturer of the pipe, and with sufficient width to provide free working space at both sides of trench and around installed item as required for caulking, joining, backfilling, and compacting. For underground pipe and conduit, trench width is to be calculated based on a minimum of 2" between all sides of the pipe and conduit and a minimum of 6" between the pipe and conduit and the trench walls.
 - 1. Where recommended trench widths are exceeded, redesign shall be performed at no extra cost to the owner, using stronger pipe or special installation procedures.
- B. Excavate trench straight and true to line and grade and to a depth below the bottom of the pipe sufficient to provide for pipe bedding material as required. Trenches over-excavated in depth shall be re-filled with suitable materials and compacted to 90 percent (90%) relative compaction.
- C. Excavations for utilities related structures and appurtenances, pull-boxes, vaults, manholes, drop inlets or similar structures shall be sufficient to leave at least 12 inches clear between the outer structure surface and face of the excavations. Provide 12" of compacted pea gravel for bedding and/or to facilitate drainage. When concrete is to be placed in an excavated area, special care shall be taken not to disturb the bottom and/or sides of the excavation.
- D. Unsatisfactory material, as determined by the District's Geotechnical Engineering Consultant, shall be removed and replaced with suitable material and then compacted as required.
- E. Where depths are not shown, trench to sufficient depth to give minimum fill above top installed item measured from adjacent finished grade as follows or as required to meet Utility Company standards:
 - 1. Electrical conduit: 24 inches
 - 2. Sewer pipe: 24 inches
 - 3. Water pipe: 30 inches
 - 4. Gas pipe: 30 inches

3.02 DEWATERING EXCAVATIONS

- A. Dewatering for excavating, backfilling and compacting for utilities is the responsibility of the Contractor.
- B. Any water that accumulates in excavations shall be drained promptly, by appropriate means.
- C. Trenching shall be controlled in the vicinity of buildings and other structures so that the surface of the ground will be properly sloped to prevent water from running into excavated areas or creating adverse drainage conditions.

3.03 BRACING AND SHORING

- A. The Contractor shall furnish, place, and maintain such bracing and shoring as necessary for the safety of workers, protection of adjacent facilities and utilities, and proper installation of pipe, in

conformance with legal requirements.

3.04 BACKFILLING

- A. Initial Pipe Bedding Backfill Placement: Initial pipe bedding backfill material around pipes shall be placed and compacted to 90 percent (90%) relative compaction (per ASTM D1557) on all sides of the pipe and simultaneously on each side of the pipe to avoid displacement of the pipe. Allow for a minimum of 2" sand bedding below the pipe, 2" between pipe, 6" above the pipe, and 6" to the trench walls. Initial pipe bedding backfill shall be placed such that it completely surrounds all pipes leaving no void areas. The District's Geotechnical Engineering Consultant shall judge and approve the suitability of the initial backfill material and placement method prior to commencement of work. Acceptable methods for consolidation include moisture conditioning and compacting with light vibratory equipment and jetting. Other methods of placement and consolidation of initial backfill may be acceptable, upon review and approval by the District's Geotechnical Engineering Consultant.
- B. Trench Backfill Placement: Subsequent trench backfill material shall be placed in loose layers not exceeding eight (8) inches in thickness, and be compacted to at least 90 percent (90%) relative compaction (per ASTM D1557). In pavement areas (asphalt and concrete), the top twelve (12) inches of backfill beneath the aggregate base section shall be compacted to at least 95 percent (95%) relative compaction. Aggregate base materials placed in pavement areas shall also be compacted to at least 95 percent (95%) relative compaction. The District's Geotechnical Engineering Consultant shall judge and approve the suitability of the trench backfill material and placement method prior to commencement of work.

3.05 DISPOSAL OF EXCESS AND UNSUITABLE MATERIALS

- A. Remove excess excavated material, trash, debris and waste materials. Dispose of off-site in a legal manner. Do not stockpile on site.

3.06 ON SITE UTILITY VERIFICATION AND REPAIR PROCEDURES

- A. Ground-breaking requirements:
1. All underground work performed by a Contractor must be authorized by the District's Construction Manager or the Low Voltage Consultant prior to start of construction.
 2. The Contractor is to obtain and keep the original School's construction utility site plans on site during all excavation operations. Contractor can contact the District's Construction Manager or the Low Voltage Consultant to procure the drawings.
- B. Underground Utility Locating:
1. The contractor shall hire an Underground Utility Locating Service to locate existing underground utility pathways in areas effected by the scope of work for excavation.
 2. Contractor must use an underground utility locator service with a minimum of 3 years experience. The equipment operator must have demonstrated experience. Contact Norcal Underground Locating (800/986-6722) or Precision Locating (800/577-7324)
 3. The Underground Utility Locator Service must have the use of equipment with the ability to locate by means of inductive clamping, induction, inductive metal detection, conductive coupling, or TransOnde (Radiodetection) to generate signals, passive locating (free

scoping) for “hot” electric, and metal detector.

4. The Underground Utility Locator Service must be able to locate existing utilities at a depth of at least 72”.
5. The Underground Utility Locator Service must be able to locate but are not limited to locating the following types of utility pathways:
 - a. All conduit pathways containing 110 volt or greater 50-60Hz electrical wire.
 - b. All conduit pathways containing an active cable TV system.
 - c. All conduit pathways containing wire or conductor in which a signal can be attached and generated without damaging or triggering the existing systems.
 - d. All empty conduit pathways or pipe in which a signal probe or sonde (miniature transmitter) can be inserted.
 - e. All conduit pathways containing non-conductive cables or wires in which a signal probe or sonde (miniature transmitter) can be inserted.
 - f. All plastic and other nonconductive water lines in which a TransOnde (Radiodetection) or other “transmitter” can be applied to create a low frequency pressure wave (signal) without damaging or triggering the existing systems.
6. All markings made by the Underground Utility Locator Service or other shall be clear and visible.
7. The contractor shall maintain all markings made by Underground Utility Locator Service or other throughout the entire length of the project.
8. The Underground Utility Locator Service shall provide the contractor with two sets of maps showing the location of utilities and average depth. They will be referenced to permanent buildings. Contractor will deliver one copy to the district (Plan Room) at no additional charge.
9. Contractor is responsible to contact Underground Service Alert (U.S.A. 800/227-2600) and receive clearance prior to any excavation operations.
10. Contractor shall inform the District’s Construction Manager or Low Voltage Consultant no later than five (5) days prior to the date scheduled for the utility locator service to be on site.

C. Damage to existing utilities procedures:

1. Contractor shall locate all utility shut-off valves prior to excavation operations.
2. Contractor will be responsible for any damage to existing, located, utilities.
3. Contractor will be responsible for any damage to existing utilities plus or minus five (5’) feet in either direction of the located utilities and utilities as shown on the original School’s construction utility site plans.

4. Contractor will not be responsible for damage to any existing utility that was not located by the utility locator service or utilities not shown on the original School's construction utility site plans.
5. Contractor is to notify the District's Construction Manager or Low Voltage Consultant immediately when a utility is broken.
6. All damaged electrical power or low voltage utilities shall be replaced. Splicing of damaged electrical power or low voltage utilities is not allowed.
7. Contractor shall provide test-results for all replaced electrical power or low voltage utilities indicating that the system has been restored to proper working order.
8. All repairs of broken utilities, except Fire Intrusion Detection Systems (FIDS), are the responsibility of the contractor. Fire Intrusion Detection Systems lines will be repaired by a licensed and certified FIDS engineer and/or District personnel. All repair costs will be back-charged to the contractor.
9. The contractor shall contact the District's Construction Manager or Low Voltage Consultant who will contact the appropriate District department prior to contractor back-filling the trench. Each District department will verify system repair before trench is to be back filled.
10. Contractor is responsible for maintaining all utility markings made by the utility locator service, District, or others from time of first marking to the end of the project. The contractor is required to provide marked as-built drawings to the District's Construction Manager or Low Voltage Consultant from the utility locator service of all utilities encountered within plus or minus five (5') feet in either direction of the area of the excavation.

END OF SECTION

**SECTION 32 12 16
ASPHALT PAVING**

PART 1 – GENERAL

1.01 SECTION INCLUDES

- A. Description of requirements for materials and installation of new and repair of asphalt concrete paving, modifications and patching and related work as shown on Drawings and necessary to complete the work.

1.02 RELATED SECTIONS

- A. Section 00 70 00: General Conditions
- B. Section 02 41 00: Demolition
- C. Section 03 30 00: Cast-in-Place Concrete
- D. Section 31 00 00: Earthwork
- E. Section 32 13 13: Concrete Paving

1.03 QUALITY ASSURANCE

- A. Qualifications of Asphalt Concrete Producer: Use only materials which are furnished by bulk asphalt concrete producers regularly engaged in production of hot-mix, hot-laid asphalt concrete.
- B. Applicator Qualification: Company specializing in the application of asphalt concrete paving with two (2) years documented experience.
- C. Reference and Standards:
 - 1. American Society for Testing and Materials (ASTM)
 - 2. State of California, Business and Transportation Agency, Department of Transportation (CSS) - "Standard Specifications", (latest Ed.).
 - 3. Redwood Inspection Service (RIS) - "Standard Specifications for Grades of California Redwood Lumber", with Supplements No. 1 and No. 2.
- D. Design Criteria: Asphalt concrete paving shall show no evidence of cracking, uneven settlement or improper drainage. Correct work displaying such conditions under the Contractor's warranty of all work.
- E. Allowable Tolerances: Unless noted otherwise, finish surface shall be true to established elevations within 1/8-inch in ten feet as measured from a 10 foot straight edge in any direction.
 - 1. No tolerances shall be allowed for slopes and elevations noted for accessible parking stalls, loading aisles, and access aisles. Contractor shall be responsible for the removal and replacement of paving which exceeds the maximum slope noted on the Construction Documents.

1.04 SUBMITTALS

- A. Submit under provisions of Section 01 33 00.
- B. Product data: Submit product data for all materials intended for use and certification of compliance with standards specified.
- C. Soil Sterilizer: Upon completion of application of soil sterilizer applicator shall furnish the following information to Architect: Project name, applicator's name and license number, chemicals and mixture used, area treated (sq. feet) and date of application.

1.05 ENVIRONMENTAL CONDITIONS

- A. Do not lay base course on muddy subgrade during wet weather or when atmosphere temperature is below 40 degrees F.
- B. Do not apply asphalt concrete surfacing on wet base during wet weather or when atmospheric temperature is below 40 degrees F.

1.06 PRODUCT DELIVERY, STORAGE AND HANDLING

- A. Cover loads of asphalt concrete with tarpauline during transport to site.
- B. Deliver, store, and handle packaged products in original containers with seals unbroken and labels intact until time of installation.
- C. Store delivered products in clean, safe, dry area.

PART 2 – PRODUCTS

2.01 MATERIALS

- A. Soil sterilizer shall be CIBA GEIGY's Pramitol 25-E or Thompson-Hayward Casoron.
 - 1. Soil sterilizer shall be applied in strict accordance with manufacturer's instructions.
- B. Aggregate Base: Class 2 aggregate base conforming to CSS Section 26.
- C. Asphalt Binders: Steam-refined paving asphalt conforming to CSS Section 92, viscosity grade AR 4000.
- D. Paint Binders: Conform to requirements of CSS Section 94.
- E. Asphalt concrete: conform to requirements of CSS Section 39 for Type B asphalt with 1/2 inch maximum medium aggregate size using AR 4000 asphalt for binder.
- F. Seal Coat: shall be a pre-mixed asphalt emulsion blended with select fillers and fibers such as:
 - 1. "Park-Top No. 302", Western Colloid Products.

2. "Overcote", Reed and Graham.

G. Headerboards: 2x6 Foundation Grade Redwood.

1. Use 1/2 inch thick boards where required for bending.

2.02 PAVING STRUCTURAL SECTION

A. Asphalt Concrete Paving - Pedestrian walk.

1. Asphalt concrete: 2 inches Type B using 1/2-inch maximum medium grading aggregates.

2. Paint Binder: As specified herein.

3. Soil Sterilizer: As specified herein.

4. Aggregate Base: 4 inch Class 2 aggregate base.

B. Asphalt Concrete Paving - Driveway and heavy traffic areas:

1. Same as "A" above except:

a. 3" type B asphalt concrete

b. 12" class 2 aggregate base

C. Asphalt Concrete Paving – Parking Lots and Hardcourts:

1. Same as "A" above except:

a. 3" type B asphalt concrete

b. 8" class 2 aggregate base

2.03 MIXING

A. Mix surface course aggregate and asphalt binder in central mixing plant in accordance with CSS Section 39 by either batch mixing or continuous mixing to produce uniform distribution of binder.

B. Plant shall be equipped with accurately calibrated devices 320 degrees Fahrenheit for control of temperature and weight of both ingredients.

C. Ensure temperature of asphalt concrete does not exceed 320 degrees Fahrenheit at anytime and is not less than 250 degrees Fahrenheit at time of delivery.

2.04 PAVEMENT MARKING PAINT

A. Approved Manufacturers: Glidden Professional Latex Traffic Paint", Dunn-Edwards Corp. "Traffic Paint W-801" or approved equal.

B. Colors:

1. Stripping and Lettering: White, Blue where required at access aisle borders.
2. Limited Parking: Green.
3. Disabled Access: Blue. Blue paint shall match Color No. 15090 of Federal Standard 595B and white.
4. Caution and Bus Loading: Yellow.
5. Fire Lane: Red.
6. Black Out Stripping: Black.
7. Paint surface shall have a static coefficient of friction of .6 or greater.

PART 3 – EXECUTION

3.01 INSPECTION

- A. Examine areas to receive asphalt concrete and verify following:
 1. That related work such as concrete work, headers, etc. have been set at proper elevations or that conditions will permit adjustment to proper elevations.
 2. Absence of wet receiving surfaces or other conditions to adversely affect execution of this work.
- B. Do not start work until unsatisfactory conditions have been corrected.

3.02 PREPARATION

- A. Subgrade:
 1. Verify areas have proper compaction and Testing Lab has accepted prior to placement of base material and again prior to placement of asphalt.
 2. Ensure areas are true to line and grade, dry, properly prepared and free from loose or foreign material.
- B. Do not proceed until subgrade has been inspected and approved by Architect.
- C. Notify Architect 48 hours in advance of performing paving work.
- D. Sawcut existing paving in straight lines to provide uniform joints at transitions.

3.03 APPLICATION

- A. Grade Control: Establish and maintain required lines and grades including the crown and cross slope for each course during all application operations.
- B. Aggregate Base: Spread and compact in accordance with CSS Section 26, to thickness, lines

and grades noted.

- C. Soil sterilizer shall be applied only to areas indicated to receive paving. Apply over aggregate base after base has been compacted and just prior to application of prime coat. Do not spread sterilizer beyond areas to receive paving. Soil sterilizer shall be applied by a professional applicator holding a valid State Agricultural Pest Control license.
- D. Paint Binder: Apply at rate of 0.05 to 0.10 gallon per square yard to all vertical surfaces of curbs, aprons, and construction joints in surfacing against which additional material is to be placed in accordance with CSS Section 39-4.02.
- E. Asphalt concrete:
 - 1. Spread and compact in accordance with CSS Section 39-5, to thickness noted using minimum eight-ton self-propelled rollers.
 - 2. Provide smooth side and water-resistant surfaces, true within tolerances specified, and free of bird baths.
 - 3. Bring asphalt concrete to edges of concrete paving or walks, adjacent paving, and header boards; do not overlay these items.
 - 4. Roll Surfaces longitudinally; cross-rolling will be required where space permits.
- F. Header Boards: Install redwood header boards as edging for asphalt concrete paving where shown on the drawings. Install header boards true to line and grade, securely anchored in place. Use three (3) 1/2" thick boards where required at curves. Anchors shall be 2" x 3" x 24" long redwood stakes spaced a maximum of 4'-0" o.c. and shall not be visible upon completion of paving.

3.04 PAVEMENT SEALER (Seal Coat)

- A. Seal coat emulsion shall not be applied to newly constructed asphalt concrete surfaces until 30 days after spreading and compacting of the new asphalt concrete.
- B. Surface Preparation: surface shall be clean of all dirt, sand, oil or grease. Broom, blow or hose down entire area with a strong jet of water to remove all debris.
 - 1. Remove soft, loose, or otherwise damaged areas of asphalt concrete to full depth of damage and replace with compacted asphalt concrete as specified herein.
 - a. Minor holes and imperfections may be patched using hot mix asphalt or mastic using sand/SS-1-H.
 - 2. Use wire brush for removal of oil and grease; prime with shellac or synthetic resin as recommended by manufacturer of pavement sealer material.
 - 3. Surfaces that have weathered excessively or are dusted shall be primed with a solution of 1 to 4 parts cool, clean water and 1 part of SS-1-H. Apply at the rate of 1 gallon per sq. ft. and allow to dry. If in doubt a test patch shall be tried.
- C. Seal Coat Application: Thoroughly mix materials and apply in accordance with manufacturer's

- D. Clean-Up and Precautions: As recommended by pavement sealer material manufacturer.

3.05 PAVING MARKINGS

- A. Painted pavement markings shall be done only after the seal coat has thoroughly dried.
- B. Clean surfaces to be painted with traffic paint of dust, dirt, grime, oil, rust or other contaminants which will impair the quality of work or interfere with proper bond of paint coats. Surfaces shall be cleaned to the extent and by whatever means that will satisfactorily accomplish the purpose without damage to asphalt concrete.
- C. Provide measured layouts, temporary markings, templates, and other means necessary to provide required marking.
- D. Prepare and apply paint in accordance with manufacturer's instructions; paint shall be applied by spray and shall achieve complete coverage free from voids and thin spots.
- E. Where indicated on the Drawings, paint parking stall strips, lettering, arrows, accessible symbols, playfield markings, etc. on asphalt concrete paving. Paint strips shall be 4 inches wide (except otherwise indicated) and applied with two (2) coats of herein specified Traffic Line Paint; white (except as otherwise specified or indicated).
 - 1. International Symbol of Accessibility: Symbol shall be white figures on a blue background with white border. Blue shall be equal to color No. 15980 in Fed. Std. 595B.
- F. Lines and symbols shall be accurately formed and true to line and form; lines shall be straight and uniform in width.
- G. Painted edges shall be clean cut and free from raggedness, and corners shall be cut sharp and square.
- H. Tolerances: Unless noted otherwise, apply striping within a tolerance of 1/2 inch in 50 feet. Apply markings and striping to widths indicated with a tolerance of 1/4 inch on straight sections and 1/2 inch on curved sections.
 - 1. No tolerances shall be allowed for striping which violates minimum requirements for accessible parking stalls, loading aisles, and access aisles. Contractor shall be responsible for the removal and replacement of striping which violates the accessible dimensions noted on the Construction Documents.

3.06 PAVING PATCHING AND REPAIR

- A. Paving Patching and Repair: All paving that is damaged due to trenching, etc., or that is damaged due to construction under this Contract, shall be repaired and/or replaced hereunder as determined by Architect with new paving and base. All work shall be in accordance with the applicable material and application requirements specified herein.
 - 1. Saw cut existing asphalt concrete paving at all areas indicated or required for new

construction work and at edges of paving to be replaced and remove debris from the site. Excavation work and removal of material and backfill below bottom of base shall be the responsibility of the trade involved in the work.

3.07 TESTING

A. Complete surfacing shall be thoroughly compacted smooth, true to grade and cross section, free from ruts, humps, depressions or irregularities. After the surfacing has been placed the entire area shall be tested for proper drainage by applying water in sufficient amount to cover the surface. If any portion fails to drain properly, the condition shall be corrected by patching with asphalt concrete until correction of improper drainage is completed.

1. No ponding water is acceptable on new paving or adjacent areas caused by new work.

3.08 PROTECTION

A. After final rolling, do not permit vehicular traffic on asphalt concrete pavement until it has cooled and hardened, and in no case sooner than six (6) hours.

1. Provide barricades and warning devices as required to protect pavement.

[END OF SECTION 32 12 16]

**SECTION 32 13 13
CONCRETE PAVING**

PART 1 – GENERAL

1.01 SECTION INCLUDES

- A. The Section describes the requirements for providing portland cement concrete paving, including accessibility ramps, sidewalks, accessible routes of travel, and for other non-structural or non-vehicular applications.

1.02 RELATED SECTIONS

- A. Section 00 70 00: General Conditions.
- B. Section 07 90 00: Joint Protection.
- C. Section 31 00 00: Earthwork.
- D. Section 32 17 26: Tactile Warning Surfaces

1.03 SUBMITTALS

- A. Product data: Furnish for proprietary materials and items, including reinforcement and forming accessories, admixtures, joint systems, curing compounds, and other materials requested by the Architect.
- B. Design Mixes: Furnish for each class of concrete.
- C. Laboratory Test Reports: Submit evaluation of concrete materials and mix design tests.
- D. Control/Expansion Joints: Submit proposed control and expansion joint layout clearly identifying locations/types of each and joint patterns as shown in the Contract Documents.
- E. Concrete mockup of separate concrete finishes including medium broom finish, control joint, expansion joint, and seeded aggregate. Mockup shall be completed by actual crew to perform work on site. Size of mockup shall be 4'-0" x 4'-0" and shall be used to review all other site work by. At end of project, contractor shall dispose of mockup.

1.04 QUALITY ASSURANCE

- A. Concrete Standards: Comply with provisions of the following standards except where more stringent requirements are specified:
 - 1. ACI 211.1, "Standard Practice for Selecting Proportions for Normal Weight, Heavy Weight and Mass Concrete".
 - 2. ACI 301, "Specifications for Structural Concrete for Buildings".
 - 3. ACI 304R, "Guide for Measuring, Mixing, Transporting and Placing Concrete".
 - 4. ACI 305R, "Hot Weather Concreting".

5. ACI 306R, "Cold Weather Concreting".
 6. ACI 309R, "Guide for Consolidation of Concrete".
 7. ACI 318, "Building Code Requirements for Structural Concrete".
 8. CRSI, "Manual of Standard Practice".
- B. Concrete Manufacturer: Complying with ASTM C94 / C94Ma requirements for production facilities and equipment.
- C. Concrete Testing Service: Engage an independent testing agency to perform materials evaluation tests and to design concrete mixes.

1.05 JOB CONDITIONS

- A. Traffic Control: Maintain access for vehicular and pedestrian traffic as required for construction activities.

PART 2 – PRODUCTS

2.01 MATERIALS

- A. Forms: Steel, wood, or other suitable materials of size and strength to resist movement during concrete placement and to retain alignment until removal.
1. Use straight forms, free of distortion and defects.
 2. Use flexible spring steel forms or laminated boards to form radius bends as required.
 3. Coat with a non-staining form release agent that will not discolor or deface concrete.
- B. Concrete Reinforcement:
1. Reinforcing Bars and Tie Bars: ASTM A615 / A615M-09b, Grade 60, deformed.
 2. Welded Wire Mesh: Welded plain cold-drawn steel wire fabric, ASTM A185 / A185M-07. Furnish in flat sheets, roll goods will not be allowed.
 3. Joint Dowel Bars: Plain steel bars, ASTM A615 / A615M-09b, Grade 60. Cut bars true to length with ends square and free of burrs.
 4. Supports and Reinforcement: Chair, spacers, dowel bar supports and other devices for spacing, supporting, and fastening reinforcing bars., welded wire fabric, and dowels in place. Use wire bar-type supports complying with CRSI specifications.
- C. Concrete:
1. Portland Cement: ASTM C150 / C150M-09, Type I.
 2. Fly Ash: ASTM C618 – 08a, Type F.

3. Normal-Weight Aggregates: ASTM C33 / C33M-08, Class 4, and as follows. Provide aggregates from a single source.
 - a. Maximum Aggregate Size: 1 inch.
 - b. Do not use fine or coarse aggregates that contain substances that cause spalling.
 - c. Local aggregate not complying with ASTM C33 / C330-08 that have been shown to produce concrete of adequate strength and durability may be used when acceptable to the Architect.

- D. Water: Potable.

- E. Admixtures:
 1. Water-Reducing Admixture: ASTM C494 / C494M-08a Type A.
 2. High-Range Water-Reducing Admixture: ASTM C494 / C494M-08a, Type F or G.
 3. Water-Reducing and accelerating Admixture: ASTM C494 / C494M-08a, Type E.
 4. Water-Reducing and Retarding Admixture: ASTM C494 / C494M-08a, Type D.

- F. Curing Materials:
 1. Absorptive Cover: Burlap cloth made from jute or kenaf.
 2. Moisture-Retaining Cover: Waterproof paper of polyethylene film.
 3. Clear Waterborne Membrane-Forming Curing Compound: ASTM C309 - 07, Type I, Class B.
 4. Evaporation Control: Monomolecular film-forming compound applied to exposed concrete slab surfaces for temporary protection from rapid moisture loss.

- G. Related Materials:
 1. Bonding Agent: Acrylic or styrene butadiene.
 2. Epoxy Adhesive: ASTM C881 / C881M-02, two-component material suitable for dry or damp surfaces. Provide material, type, grade, and class to suit requirements.

- H. Handrail and Guiderail Plastic Sleeves:
 1. At all embedded pipe supports into new concrete, contractor shall use a plastic tapered insert that shall be removed prior to rail installation. Product shall be equal to EZ SLEEVE as manufactured by Wagner (888) 243-6914.
 2. Contractor shall set all inserts plumb and level with finished surface. Locations of inserts shall be closely coordinated by Contractor with handrail requirements including spacing

and pipe size requirements as identified in approved handrail shop drawings as required by other spec sections.

I. Seeded Aggregate:

1. At all locations as shown on drawings, provide seeded aggregate. Aggregate shall be a high grade stone, approximately 1/4" diameter and shall be cubical or rounded with rough surface. Flat pieces or slivers with glossy surfaces shall not be used. Color shall be selected from full line of manufacturer's colors.

2.02 CONCRETE MIX

- A. Prepare design mixes for each type and strength of normal-weight concrete by either laboratory trial batch or field experience methods as specified in ACI 301. For the trial batch method, use a qualified independent Testing Agency for preparing and reporting proposed mix designs.
- B. Proportion mixes according to ACI 211.1 and ACI 301 to provide normal weight concrete with the following properties:
 1. Compressive Strength at 28 Days: 2,500 psi.
 2. Maximum Water-Cement Ratio at Point of Placement: 0.65.
 3. Slump Limit at Point of Placement: 3-inches.
- C. Adjustment to Concrete Mixes: Mix design adjustments may be requested by the contractor when characteristics of materials, project conditions, weather, test results or circumstances warrant.

2.03 CONCRETE MIXING

- A. Ready-Mixed Concrete: Comply with ASTM C94 / C94M – 09a.
 1. When air temperature is between 85-deg. F. and 90-deg. F., reduce mixing and delivery time from 1-1/2 hours to 75-minutes. When air temperature is above 90-deg. F., reduce mixing and delivery time to 60-minutes.

PART 3 – EXECUTION

3.01 SURFACE PREPARATION

- A. Proof-roll prepared subgrade surface to check for unstable areas and required additional compaction.
- B. Remove loose material from compacted subgrade immediately before placing concrete.
- C. Do not begin paving work until unsatisfactory conditions have been corrected.

3.02 FORM CONSTRUCTION

- A. Set forms to required grades and lines, rigidly braced and secured.

1. Install sufficient quantity to allow continuous progress of work.
2. Check completed formwork for grade and alignment to following tolerances:
 - a. Top of forms not more than 1/8 inch in 10 feet.
 - b. Vertical face on longitudinal axis, not more than 1/4 inch in 10 feet.
3. Clean forms after each use, and coat with form release agent as required.

3.03 REINFORCEMENT

- A. General: Comply with CRSI recommended practice for "Placing Reinforcing Bars" for placing and supporting reinforcement.
- B. Clean reinforcement of loose rust and mill scale, earth, or other bond-reducing materials.
- C. Arrange, space, and securely tie bars and bar supports to hold reinforcement in position during concrete placement. Maintain minimum cover to reinforcement.
- D. Install welded wire fabric in lengths as long as possible. Lap adjoining pieces at least one full mesh and lace splices with wire. Offset laps of adjoining widths to prevent continuous laps in either direction.

3.04 JOINTS

- A. General: Construct contraction, construction, and isolation joints true to line with faces perpendicular to surface plane of concrete. Construct transverse joints at right angles to the centerline unless otherwise indicated.
- B. Joints at Existing Concrete: All joints between existing concrete and new concrete are to include dowels a minimum of #3 bars at 4'-0" on center, 18" maximum from the ends, epoxy set into existing concrete a minimum of 6" in length at the centerline of the existing concrete slab.
- C. Contraction Joints (Control Joints): Provide weakened-plane contraction joints, sectioning concrete into areas indicated. Construct contraction joints for a depth equal to at least 1/4 of the concrete thickness. Form in fresh concrete by grooving and finishing each edge of joint with a radiused jointer tool. These joints shall be placed to divide up new concrete paving into sections no larger than 75 sq. ft.
- D. Construction Joints: Set construction joints at side and end terminations of paving and at locations where paving operations are stopped for more than 1/2 hour, unless paving terminates at isolation joints.
 1. Provide preformed galvanized steel or plastic keyway-section forms or bulkhead forms with keys. Embed keys at least 1-1/2 inches into concrete.
 2. Continue reinforcement across construction joints.
 3. Use bonding agent on existing concrete surfaces that will be joined with fresh concrete.
- E. Isolation Joints (Expansion Joints): Form isolation joints of preformed joint filler strips abutting

concrete curbs, catch basin, manholes, inlets, structures, walks, other fixed objects, and where indicated.

1. Provide 3/8" wide fiber expansion joint material, Model No. 320-F, as manufactured by W.R. Meadows or equal.
2. Provide Snap-Cap as manufactured by W.R. Meadows or equal. Snap-Cap shall have a top plastic edge that can be used for leveling concrete. Once concrete has set up, top edge of Snap-Cap can be pulled free and discarded. Joint shall then be sealed.
3. Maximum spacing shall be 20'-0" on center, each way, or as otherwise noted on drawings.

F. See Specification Section 07 90 00 for joint protection.

3.05 CONCRETE PLACEMENT

- A. Inspection: Before placing concrete, inspect and complete formwork installation, reinforcing steel, and items to be embedded or cast-in.
- B. Remove frost from subbase and reinforcing before placing concrete.
- C. Moisten subgrade if required to provide a uniform dampened condition at time concrete is placed. Do not place concrete around manholes or other structures until they are at required finish elevations and alignment.
- D. Comply with requirements of ACI 304R for measuring, mixing, transporting, and placing concrete.
- E. Deposit and spread concrete in a continuous operation between transverse joints. Do not push or drag concrete into place or use vibrators to move concrete into place.
- F. Use a bonding agent at locations where fresh concrete is placed against hardened or partially hardened concrete surfaces.
- G. Consolidate concrete by mechanical vibrating equipment supplemented by hand-spading, rodding, or tamping. Use equipment and procedures to consolidate concrete complying with ACI 309R.
 1. Consolidate concrete along face of forms and adjacent to transverse joints with internal vibrator. Keep vibrator away from joint assemblies, reinforcement and side forms.
 2. Use only square faced shovels for hand-spreading and consolidation. Carefully consolidate to avoid dislocating reinforcing, dowels and joints.
- H. Screed paved surfaces with a straightedge and strike off. Use bull floats or darbies to form a smooth surface plane before excess moisture or bleed water appears on the surface. Do not further disturb concrete surfaces prior to beginning finishing operations.
- I. Curbs and Gutters: If automatic machine placement is used for curb and gutter placement, submit revised mix design and laboratory test results. Machine placement shall produce curbs and gutters to required cross-section, lines, grades, finish, and jointing as specified for formed concrete.

- J. Cold-Weather Placement: Comply with ACI 306R. Protect concrete work from physical damage or reduced strength that could be caused by frost, freezing actions, or low temperatures.
- K. Hot-Weather Placement: Place concrete complying with ACI 305R when hot weather conditions exist.

3.06 CONCRETE FINISHING

- A. Float Finish: Begin floating when bleed water sheen has disappeared and the concrete surface has stiffened sufficiently to permit operations. Float surface with power-driven floats, or by hand-floating if area is small and inaccessible to power units. Unless noted otherwise, finish surfaces to true planes within a tolerance of 1/4 inch in 10 feet. Cut down high spots and fill low spots. Refloat surface immediately to a uniform granular surface.
 - 1. Final Finish: Provide a medium textured broom finish by drawing a soft bristle broom across concrete surface perpendicular to line of traffic to provide a uniform fine line texture finish.
 - 2. No tolerances shall be allowed for slopes and elevations noted for accessible ramps, accessible curb ramps, accessible walks, and accessible routes of travel. Contractor shall be responsible for the removal and replacement of concrete work which exceeds the maximum slope noted on the Construction Documents.
- B. Final Tooling: Tool edges of paving, gutters, curbs, and joints formed in fresh concrete with a jointing tool to a radius of 1/4 inch. Repeat tooling of edges and joints after applying surface finishes. Eliminate tool marks on concrete surfaces.
- C. Seeded Aggregate:
 - 1. Seed new concrete by shovel or hand to completely cover entire surface with one layer of stone. Tap stones securely into concrete mix. Use rolling device to properly complete this task. Use magnesium float until aggregate is entirely embedded and mortar completely surrounds and slightly covers stones. Appearance after embedment should be similar to a normal slab after floating. Special care shall be taken to see that stones are not over embedded. Take care to not mix embedded aggregate with the course aggregate of the base concrete.
 - 2. Expose embedded by first lightly brushing slab with stiff nylon bristle broom. If aggregate is dislodged, more time is required for the concrete to set up. Next, brushing combined with a fine water spray can begin. This is a multi-step procedure requiring several passes to allow mortar to set up after each pass. It is extremely important that the aggregate have a uniform exposure at the end of washing and brushing. Several passes will be required before the proper exposure is obtained. Continue washing and brushing until exposure is uniform and at the proper depth, the flush water runs clear and there is no noticeable cement film on the aggregate.

3.07 CONCRETE PROTECTION AND CURING

- A. General: Protect freshly placed concrete from premature drying and excessive cold or hot temperatures. Comply with the recommendations of ACI 306R for cold weather protection and ACI 305R for hot weather protection during curing.
- B. Evaporation Control: In hot, dry, and windy weather, protect concrete from rapid moisture loss

before and during finishing operations with an evaporation-control material. Apply in accordance with manufacturer's instructions after screeding and bull floating, but before floating.

- C. Begin curing after finishing concrete but not before free water has disappeared from concrete surface.
- D. Curing Methods: Cure concrete by moisture curing, moisture-retaining-cover curing, curing compound, or a combination.
 - 1. Moisture Curing: Keep surfaces continuously moist for not less than 7 day with water, a continuous water-fog spray, or absorptive cover kept continuously wet.
 - 2. Moisture Retaining Cover: Cover concrete with moisture retaining cover with side and end laps sealed.
 - 3. Curing Compound: Apply in accordance with manufacturer's instructions. Recoat areas subjected to rainfall within 3 hours after initial application.

3.08 FIELD QUALITY CONTROL TESTING

- A. Employ a qualified independent Testing Agency to sample materials, perform tests, and submit test reports during concrete placement.

3.09 REPAIRS AND PROTECTION

- A. Repair or replace broken or defective concrete, as directed by Architect.
- B. Protect concrete from damage until acceptance of work. Prohibit traffic for at least 14 days after placement.
 - 1. When construction traffic is permitted, remove surface stains and spillage of materials as they occur.
 - 2. Sweep concrete pavement and wash free of stains, discolorations, dirt and other foreign material prior to final inspection.

END OF SECTION

**SECTION 32 17 13.19
PRECAST CONCRETE PARKING BUMPERS**

PART 1 – GENERAL

1.01 WORK INCLUDED

- A. Provide precast concrete wheel stops for adhesive and metal stake installation as indicated on Drawings and specified here.

1.03 RELATED WORK

- A. Section 32 12 16: Asphalt Concrete Paving.
- B. Section 32 13 13: Concrete Paving.

1.04 REFERENCES

- A. Standard Specifications of the California State Department of Transportation (CALTRANS), latest edition.

PART 2 – PRODUCTS

2.01 MATERIALS

- A. Precast concrete wheel stops, 3,500 psi concrete, fully reinforced.
- B. Epoxy Adhesive: Comply with the requirements of Caltrans Standard Specification Section 95-2.05, "Standard Set Epoxy for Pavement Markers", (State Spec. 8040-21M-09).
- C. Anchor Stakes: #4 steel rebar x minimum 18 inches long, minimum two stakes per stop.

PART 3 – EXECUTION

3.01 INSTALLATION

- A. Carefully coordinate placement of wheel stops with the layout of parking stalls and traffic aisles, providing proper angle to engage wheels and proper locations to prevent overtravel of vehicles.
- B. Install wheel stop in full bed of epoxy adhesive and by driving rebar stake through holes provided in stops. Rebar shall not extend above top of wheel stop.
- C. At portland cement concrete paving, pre-drill pavement prior to driving rebar stakes.
- D. Upon completion of installation, visually inspect each installed wheel stop and verify that each is in perfect condition and properly set.

3.02 ADJUST AND CLEAN

- A. Remove all excess adhesive.

END OF SECTION

**SECTION 32 17 26
TACTILE WARNING SURFACES**

PART 1 – GENERAL

1.01 SECTION INCLUDES

- A. Cast in Place Tactile Detectable Warning Tiles where shown on Drawings.
- B. Surface Applied Tactile Detectable Warning Tiles where shown on Drawings.

1.02 RELATED SECTIONS

- A. Section 31 13 13: Concrete Paving

1.03 REFERENCES

- A. California Building Code (2010) – Title 24

1.04 SUBMITTALS

- A. Submit shop drawings of installation at each location indicated on the Drawings clearly showing full extent of area of work.
- B. Provide product data on specified products, describing physical and performance characteristics, sizes, patterns and colors.
- C. Submit two samples approximately 6 x 12 inches in size, of each type, illustrating color and pattern for tile specified. Submit color chart clearly indicating manufacturer's full range of standard colors.
- D. Submit manufacturer's installation instructions under provisions of Section 01 33 00.

1.05 MAINTENANCE DATA

- A. Submit cleaning and maintenance data under provisions of Section 01 33 00.

1.06 ENVIRONMENTAL REQUIREMENTS

- A. Environmental Conditions and Protection: Maintain minimum temperature of 40 degrees F in spaces to receive tactile tiles for at least 48 hours prior to installations, during installation, and for not less than 48 hours after installation. Store the detectable/tactile tiles material in spaces where they will be installed for at least 48 hours before beginning installation. Subsequently, maintain minimum temperature of 40 degrees F in areas where work is completed.

1.07 EXTRA MATERIALS

- A. Provide 2 individual 24" x 36" tiles, of each type, under provisions of Section 00 70 00.

PART 2 – PRODUCTS

2.01 MATERIALS

A. Cast in Place Tactile Detectable Warning Tiles:

1. Vitrified Polymer Composite (VPC) Cast In Place Detectable/Tactile Warning Surface Tiles shall be an epoxy polymer composition with an ultra violet stabilized coating employing aluminum oxide particles in the truncated domes.
2. The tile shall incorporate an in-line pattern of truncated domes configuration conforming to the requirements of the DSA IR 11B-04.
3. For wheelchair safety the field area shall consist of a non-slip surface with a minimum of 40 - 90° raised points 0.045" high, per square inch.
4. Color to be selected by Architect from manufacturer's full range of standard colors.
5. Tiles to be Nominal 3 ft. by 2 ft. by 1.375 inches thick; 1.575 inches thick at the domes, with 1-3/8" inch deep perimeter flange and seven 1 3/8" deep internal flanges and be designed for cast in place installation as manufactured by:
 - a. Engineered Plastics. (Armor Tile)
300 International Drive, Suite 100
Williamsville, NY 14221
1-800-682-2525
 - b. Approved equal.

B. Surface Applied Tactile Detectable Warning Tiles:

1. Vitrified Polymer Composite (VPC) Surface Applied Detectable/Tactile Warning Surface Tiles shall be an epoxy polymer composition with an ultra violet stabilized coating employing aluminum oxide particles in the truncated domes.
2. The tile shall incorporate an in-line pattern of truncated domes configuration conforming to the requirements of the California Building Code (2010) Title 24.
3. For wheelchair safety the field area shall consist of a non-slip surface with a minimum of 40 - 90° raised points 0.045" high, per square inch.
4. Color to be selected by Architect from manufacturer's full range of standard colors.
5. Tiles to be Nominal 3 ft. by 2 ft. by 1.375 inches thick; 1.575 inches thick at the domes, with 1-3/8" inch deep perimeter flange and seven 1 3/8" deep internal flanges and be designed for cast in place installation as manufactured by:
 - a. Engineered Plastics. (Armor Tile)
300 International Drive, Suite 100
Williamsville, NY 14221
1-800-682-2525
 - b. Approved equal.

PART 3 – EXECUTION

3.01 PREPARATION

- A. Thoroughly clean new or existing surface. Remove all debris, dirt, grease, etc., at full extent of area to receive tile application.

3.02 INSTALLATION

A. Cast in Place Tactile Detectable Warning Tiles:

1. During Cast-In-Place Detectable/Tactile Warning Tile installation procedures, ensure adequate safety guidelines are in place and that they are in accordance with the applicable industry and government standards.
2. The specifications of the structural embedment flange system and concrete sealants and related materials shall be in strict accordance with the contract documents and the guidelines set by their respective manufacturers.
3. The physical characteristics of the concrete shall be consistent with the contract specifications while maintaining a slump range of 4 - 7 to permit solid placement of the Cast-In-Place Detectable/Tactile Warning Tile system. An overly wet mix will cause the tile to float, therefore under all conditions, suitable weights such as concrete blocks or sandbags (25 lb) shall be placed on each tile module.
4. Prior to placement of the Cast In Place Detectable/Tactile Warning Tile system, the contract drawings shall be reviewed and a layout drawing prepared by the installation contractor to resolve the issues related to pattern repeat, tile cuts, expansion joints, control joints, platform curves, platform end returns and platform surface interferences.
5. The concrete pouring and finishing operations require typical mason's tools, however, a mason's line, radius edge (1/8 x 3/16" return) tool, 4' long x 2" wide x 1/8" thick steel straight edge, 25 lb. weights, vibrator wand and small sledge hammer with 2" x 6" x 20" wood tamping plate are specific to the installation of the Cast-In-Place System.
6. The concrete shall be poured and finished level, true and smooth to the required dimensions prior to tile placement. Immediately after pouring concrete, a mason's line should be strung parallel to track to act as a reference line for placement of tile, and then the tile assembly shall be placed true to the platform edge and to each other on the concrete. The Cast-In-Place tiles shall be tamped or vibrated into the fresh concrete to ensure that the field level of tile is flush to the adjacent concrete or platform edge surface. The shop drawings indicate that the tile field level (base of truncated dome) is flush to adjacent surfaces to permit proper water drainage and eliminate tripping hazards between adjacent finishes. The tolerance for elevation differences between tile and adjacent surface is 1/16".
7. Immediately after tile placement, the tile elevation is to be checked to adjacent concrete or rubbing board heights with a steel straight edge. The tile elevation should be set consistent with shop drawings to permit water drainage to or away from track as the platform design dictates.
8. While concrete is workable steel edging trowel 1/8" radius x 3/16" return is to be used to

edge the tile to adjacent concrete surfaces running parallel to track. While edging, ensure that a clean edge definition is created between tile and adjacent concrete and that tile to concrete elevations meet the shop drawing tolerances.

9. The placement of Cast-In-Place Tile assemblies to each other and to the mason's line or form edge shall be true and parallel to develop a true line consistent with the platform edge. A tight tile to tile placement can best be achieved by raking out the concrete at the butting edge to avoid trapping concrete or aggregate between tiles and/or form edge.
10. During and after the tile installation and the concrete curing stage, it is imperative that there is no walking, leaning or external force placed on the tile to rock the tile, causing a void between the underside of tile and concrete.
11. Following tile placement, review installation tolerances to shop drawings and adjust tile before the concrete sets, suitable weights of 25 lb. shall be placed on each tile and additional weights at tile to tile assemblies as necessary to ensure solid contact of tile underside to concrete.
12. Following the curing of the concrete, the protective plastic wrap is to be removed from the tile face by cutting the plastic with a sharp knife tight to the concrete/tile interface. If concrete bleeding occurs between tiles, a wire brush will clean the residue without damage to the tile surface.
13. An elastomeric polyurethane sealant can be applied (not typical) to the tile edges running parallel to the track or curb. Proper surface preparation requires that the tile and adjacent surfaces are mechanically etched with sandpaper or a carbide burr and wiped clean and dry with acetone. Applications of the polyurethane sealant shall be level to the adjacent surface and a straight line formed to the tile edge. A quality installation of the sealant may require that the tile face be masked off with duct tape to ensure a clean definition of sealant to the adjacent surfaces.
14. Following the concrete curing stage, protective plastic wrap is to be removed from the tile surface by cutting the plastic with a sharp knife, tight to the concrete/tile interface. If concrete bled under the plastic, a soft brass wire brush will clean the residue without damage to the tile surface.

B. Surface Applied Tactile Detectable Warning Tiles:

1. The application of all tiles, adhesives, mechanical fasteners, and caulking shall be in strict accordance with the guidelines set by their respective manufacturers. Not recommended for asphalt applications.
2. Coordinate with the Contractor or Engineer to ensure that the surfaces being prepared and fabricated to receive the tiles are constructed correctly and adequately for tile installation.
3. Set the tile true and square to the curb ramp area or perpendicular to the path of travel as detailed in the design drawings, so that its location can be marked on the concrete surface. A thin permanent marker works well. Remove tile when done marking its location.
4. The surface to receive the Surface Applied Detectable/Tactile Warning Surface Tile is to

be mechanically cleaned with a diamond cup grinder or shot blaster to remove any dirt or foreign material. This cleaning and roughening of the concrete surface should include at least 4 inches around the perimeter of the area to receive the tile, and also along the cross pattern established by the corresponding areas on the backside of the tile. Those same areas should then be cleaned with a clean rag soaked in Acetone.

5. Immediately prior to installing the Surface Applied Detectable/Tactile Warning Surface Tile, the concrete surfaces must be inspected to ensure that they are clean, dry, free of voids, curing compounds, projections, loose material, dust, oil, grease, sealers and determined to be structurally sound and cured for a minimum of 30 days.
6. Using Acetone, wipe the backside of the tile around the perimeter and along the internal cross pattern, to remove any dirt or dust particles from the area to receive the adhesive.
7. Apply manufacturer's recommended adhesive to the backside of the tile, following the perimeter and internal cross pattern established by the tile manufacturer. Sufficient adhesive must be placed on the prescribed areas to have full coverage across the 2" width of the adhesive locator and shall be applied to within 1/4" continuously around the perimeter edge of the tile. The entire tube of adhesive shall be applied to the back of each tile, sizes 24" x 36" and greater.
8. Set the tile true and square to the curb ramp area or perpendicular to the path of travel as detailed in the design drawings.
9. Working from the center of the tile outwards, proceed to drill and install all fasteners in the tile's molded recesses.
10. Standing with both feet applying pressure around the molded recess provided in the tile, drill a hole true and straight to a depth of 3 1/2" using a 1/4" masonry drill bit. Drill through the tile without hammer option (on the drill) until the tile has been successfully penetrated, then with hammer option (on the drill) to drill into the concrete. Maintaining foot pressure on both sides of the hole while drilling prevents concrete dust from accumulating between the tile and concrete which can affect the tile being installed flush and may compromise installation integrity.
11. Immediately after drilling each hole, before moving on to the next, and while still applying foot pressure, mechanically fasten tiles to the concrete substrate using a leather bound or hard plastic mallet to set the fasteners. Ensure the fastener has been placed to full depth in the dome, straight, and flush to the top of dome. Drive the pin of the fastener with the mallet, taking care to avoid any inadvertent blows to the truncated dome or tile surface.
12. Following the installation of the fasteners, the concrete dust should be vacuumed, brushed or blown away from the tile's surface and adjacent concrete. Using Acetone on a rag, wipe the concrete around the tile's perimeter to ensure a clean, dry surface to receive perimeter sealant.
13. Manufacturer's recommended perimeter caulking sealant should be applied following the sealant manufacturer's recommendations. Tape all perimeter edges of the tile back 1/16" from the tile's perimeter edge and tape the adjacent concrete back 1/2" from the tile's perimeter edge to maintain a straight and even caulking line. Apply sealant around tile perimeter using care to work sealant into any void between the tile and concrete interface. Tool the perimeter caulking with a rounded plastic applicator or spatula to

create a cove profile between the tile and adjacent concrete. Remove tape immediately after tooling perimeter caulking sealant.

14. Do not allow foot traffic on installed tiles until the perimeter caulking sealant has cured sufficiently to avoid tracking. Curing time is weather dependant (average cure time at 75° F is 30 minutes).
15. If installing adjacent tiles, note the orientation of each tile. Careful attention will reveal that one of the long edges of the tile is different than the other in regard to the tiny dotted texture. You may also note a larger perimeter margin before the tiny dotted texture pattern begins. Consistent orientation of each tile is required in order that the truncated domes on adjacent tiles line up with each other.
16. In order to maintain proper spacing between truncated domes on adjacent tiles, the tapered edge should be trimmed off using a continuous rim diamond blade in a circular saw or mini-grinder. The use of a straightedge to guide the cut is required. All cuts should be made prior to installation of the tiles. If installing adjacent tiles, care should be taken to leave a 1/8 inch gap between each tile to allow for expansion and contraction.
17. If tiles are custom cut to size, if pre-molded recesses (to receive fasteners) are removed by the cut, or to maintain a tight installation to the substrate then any truncated dome can be center-drilled with a 1/4 inch masonry drill bit to create a through hole, and the through hole must be countersunk with a suitable carbide countersink bit to receive mechanical fasteners. Care should be taken to not countersink too widely or deeply. Fasteners should be flush with the top of the truncated dome when countersunk properly.

3.04 CLEANING AND PROTECTION

- A. Protect tiles against damage during construction period to comply with manufacturer's specification.
- B. Protect tiles against damage from rolling loads following installation by covering with plywood.
- C. Clean tiles not more than four days prior to date scheduled for inspection intended to establish date of substantial completion in each area of project. Clean tiles by method specified by tile manufacturer.

END OF SECTION

**SECTION 32 31 13
CHAIN LINK FENCES AND GATES**

PART 1 – GENERAL

1.01 SECTION INCLUDES

- A. Fence framework, fabric, and accessories.
- B. Excavation for post bases; concrete foundation for posts.
- C. Manual gates and related hardware.
- D. Modifications to existing chain link fence and gates.

1.02 RELATED SECTIONS

- A. Section 00 70 00: General Conditions.
- B. Section 08 71 00: Door Hardware.
- C. Section 32 13 13: Concrete Paving.

1.03 REFERENCES

- A. ANSI/ASTM A123 / A123M-09 - Zinc (Hot Dip Galvanized) Coatings on Iron and Steel Products.
- B. ANSI/ASTM F567- 07 - Installation of Chain Link Fence.
- C. ASTM A153- A153M-09 - Zinc Coating (Hot-Dip) on Iron and Steel Hardware.
- D. ASTM C94 / C94M – 09a - Ready-mixed Concrete.
- E. Chain Link Fence Manufacturers' Institute (CLFMI) - Product Manual.

1.04 SYSTEM DESCRIPTION

- A. Fence Height: 6'-0" unless otherwise noted.
- B. Line Post Spacing: At intervals not exceeding 10 feet.

1.05 QUALITY ASSURANCE

- A. Manufacturer: Company specializing in manufacturing the products specified in this section with minimum three years experience.
- B. Installer: Company specializing in installations of chain-link fencing with a minimum of five years of experience. If any welding is required provide welders' certificates, verifying AWS qualification within the previous 12 months.

1.06 FIELD MEASUREMENTS

- A. Verify field measurements are as indicated on shop drawings.

1.07 SUBMITTALS

- A. Submit shop drawings and product data under provisions of Section 01 33 00.
- B. Submit samples of Vinyl Slats for color selection by Architect.

1.08 WARRANTY:

- A. Manufacture of slats to provide a 25-year warranty against color fading and breakage of slats.

PART 2 – PRODUCTS

2.01 MATERIALS: General. Conform to CLFMI Product Manual

- A. Fabric:
 - 1. Non-Slatted Fabric: Standard Industrial grade, 2" mesh, 9 gauge zinc coated steel wire, top selvage twisted tight, bottom selvage knuckled end closed.
- B. Line Posts: Type, 1, round, standard weight. 2.375 inch diameter.
- C. Terminal and Corner Posts: Type I, round, standard weight, 2.875 inch diameter.
- D. Gate Posts: Type 1, round, standard weight, 4.0 inch diameter.
- E. Gate Frame: 1.66 inch diameter, for fittings and truss rod fabrication.
- F. Top Rail, Middle Brace Rail and Bottom Rail: Type I, round, standard weight, 1.66 inch diameter, plain end, sleeve coupled.
- G. Tension Wire: 7 gauge steel single strand.
- H. Tie Wires: 12 gauge aluminum alloy steel wire.
- I. Concrete: ASTM C94 / C94M-09a; Portland Cement, 2,500 p.s.i. strength at 28 days, 3 inch slump; one inch maximum sized coarse aggregate.
- J. Gate Hinges: Adjustable arm, pressed steel, galvanized. Equal to Hoover Fence Model CL-AHP-4. Provide at top and bottom of all gates.

2.03 ROLLING GATES

- A. Provide steel heavy-duty track, ball bearing hanger sleeves, overhead framing and supports, guides, stays, bracing, end stops, catches, and accessories as required for complete operable assembly.
- B. Fittings: Sleeves, bands, clips, rail ends, tension bars, fasteners and fittings; steel galvanized.
- C. Gate Hardware: Fork latch with gravity drop mechanical keepers. The lock shall not be used as the

"stop" when closing manual sliding gates.

2.04 ACCESSORIES

- A. Caps: Cast steel galvanized; sized to post diameter, set screw retainer.
- B. Fittings: Sleeves, bands, clips, rail ends, tension bars, fasteners and fittings; steel galvanized.
- C. Gate Hardware: Fork latch with gravity drop mechanical keepers; three 180 degree gate hinges per leaf and hardware for padlock. Padlock to be provided by Owner.

2.05 FINISHES

- A. Components and Fabric: Galvanized to ANSI/ASTM A123 / A123M - 09; 1.2 oz./sq. ft.
- B. Hardware: Galvanized to ASTM A153 / A153M-09, 1.2 oz./sq. ft. coating.
- C. Accessories: Same finish as framing.

PART 3 – EXECUTION

3.01 INSTALLATION

- A. Install framework, fabric, accessories and gates in accordance with ANSI/ASTM F567-07 and manufacturer's instructions.
- B. Set intermediate, terminal and gate posts plumb in concrete footings. Slope top of concrete for water runoff.
- C. Line Terminal and Gate Post Footing Depth Below Finish Grade: 3 feet and 12 inches diameter.
- D. Brace each gate and corner post to adjacent line post with horizontal center brace rail and diagonal truss rods. Install brace rail, one bay from end and gate post.
- E. Provide top rail through line post tops and splice with 6 inch long rail sleeves.
- F. Install center and bottom brace rail at corner gate leaves and all around enclosure.
- G. Stretch fabric between terminal posts.
- H. Position bottom of fabric 2 inches above finished grade.
- I. Fasten fabric to top rail, line posts and bottom tension wire with tie wire at maximum 15 inches on centers.
- J. Attach fabric to end, corner and gate posts with tension bars and tension bar clips.
- K. Install bottom tension wire stretched taut between terminal posts.
- L. Do not swing gate from building wall; provide gate posts.
- M. Install gate with fabric to match fence. Install three hinges per leaf, latch, catches, retainer and

locking clamp.

- N. All field welding to be performed by certified welder and all welds are to be ground down smooth.
- O. All areas of welds are to be thoroughly cleaned and treated with two coats of cold galvanized spray.
- P. All clamping bolts protruding from clamp shall be cut off flush to nut and exposed end of bolt shall be galvalumed. Galvanized acorn nut is also an acceptable means of protecting students from sharp edges.

3.02 ERECTION TOLERANCES

- A. Maximum variation from plumb: 1/8 inch.
- B. Maximum offset from true position: 3/8 inch.
- C. Components shall not infringe adjacent property lines.

END OF SECTION

**SECTION 32 80 01
IRRIGATION SYSTEM REPAIR**

PART 1 - GENERAL

1.01 Scope of Work

- A. The Contractor shall provide all labor, materials, transportation and services necessary to furnish and install components needed to patch, repair or modify the existing irrigation systems as shown on the Drawings and specified herein where effected by the scope of work of this contract.

1.02 Quality Assurance and Requirements:

A. Conformance:

1. All local, municipal, and state laws, and rules and regulations governing or relating to any portion of this work are hereby incorporated into and made a part of these Specifications and their provisions shall be carried out by the Contractor. Anything contained in these Specifications shall not be construed to conflict with any of the above rules and regulations or requirements of the same. However, when these Specifications and Drawings call for or describe materials, workmanship, or construction of a better quality, higher standard, or larger size than is required by the above rules and regulations, the provisions of these Specifications and Drawings shall take precedence.
2. The material and work of this section shall conform to all applicable provisions of the latest editions of the Uniform Plumbing Code, the National Electrical Code, and all codes properly governing the materials and work at the project site.
3. All electrical materials and work shall conform with California Administrative Code, Title 23, Part 3, Basic Electrical Regulations, Article 18 E 110-16.

- B. License: All work shall be performed by a C-27-California licensed Landscape Irrigation Contractor.

- C. Manufacturer's Directions: Manufacturer's directions and detailed drawings shall be followed in all cases where the manufacturers of articles used in this project furnish directions covering points not shown in the Drawings and Specifications.

- D. The Contractor and all Subcontractors involved with construction as per the Landscape Drawings shall have at the project site a complete set of all Landscape Contract Documents. Said Contract Documents shall reflect the latest revisions and plan checks, and the Contractor shall provide them upon request of the Owner/Landscape Architect.

1.03 Site Verification:

- A. Prior to commencement of work, the Contractor shall verify, at the site, all conditions and dimensions necessary for the patch, repair or other modifications to the existing irrigation system. Any discrepancies shall be reported to the Owner and Landscape Architect immediately.
- B. Contractor shall check with utility companies, and call for all underground utilities to be field marked. Contractor shall exercise extreme care in excavating and working near existing

utilities. Contractor shall be responsible for damages to existing utilities which are caused by his operation or neglect.

- 1.04 Coordination: The Landscape Contractor shall be responsible for coordination of his activities with all other trades through the Owner and General Contractor.
- 1.05 Guarantee: All irrigation work shall be guaranteed by the Contractor as to material and workmanship for a period of one year following the date of final acceptance of the project. The Contractor shall provide a written guarantee on his letterhead.
- 1.06 Protect Trees: Protect existing trees from damage and their root systems from cutting, compaction, storage of any construction materials for any length of time, spills of chemical products, etc.

PART 2 – MATERIALS

Materials shall be as specified herein unless otherwise required to match compatibility with existing materials.

2.01 PVC Pipe (Buried):

- A. General: Use only new materials of brands and types noted on drawings, specified herein, or approved equals. No substitutions of materials or equipment shall be made without prior written approval from the Architect.
- B. PVC Pressure Main Line Pipe and Fittings:
 - 1. Pressure main line piping shall be PVC Schedule 40. Pipe shall be made from an NSF (National Sanitation Foundation) approved Type 1, Grade I, PVC compound conforming to ASTM resin specification D-1784. All pipe shall meet requirements as set forth in Federal Specification PS-22-70, with an appropriate standard dimension (S.D.R.). Solvent-weld pipe joints.
 - 2. PVC threaded fittings and nipples used in pressure main construction shall be Schedule 80 PVC, 1-2, II-K NSF, conforming to ASTM testing procedure D-2466, threaded.
 - 3. PVC solvent-weld fittings shall be Schedule 40, 1-2, II-K NSF, conforming to ASTM testing procedure D-2466, solvent welded.
- C. PVC Non-Pressure Lateral Line Piping:
 - 1. Non-pressure lateral line piping shall be PVC Schedule 40 with solvent-weld joints. Pipe shall be made from NSF approved, Type 1, Grade II, PVC compound conforming to ASTM resin specification D-1784. All pipe shall meet requirements set forth in Federal Specification PS-22-70, with an appropriate standard dimension ratio. Solvent weld pipe joints.
 - 2. Fittings: Schedule 40, 1-2, II-K NSF, conforming to ASTM testing procedure D-2466, threaded or solvent welded.
- D. PVC Threaded Nipples and Risers: Schedule 80 PVC.
- E. Solvent Cement and Primer: Approved Solvent Cement and Primer as prescribed by pipe manufacturer; installation methods specified by the manufacturers for each type of pipe shall be adhered to.

- F. All PVC pipe shall be marked continuously and permanently with the following information: Manufacturer's name, nominal pipe size, schedule or class of pipe, pressure rating in P.S.I., NSF approval and date of extrusion.
- G. All fittings shall bear the manufacturer's name or trademark, material designation, size, applicable I.P.S. schedule and NSF seal of approval.

2.02 Control Wire:

- A. Connections between the automatic controllers and the electric control valves shall be made with direct burial copper wire AWG-U.F. 600 volt UL approved. Minimum size is #14 AWG buried 18" below grade. Use different color pilot wire for each controller. Common wires shall be white with a different color stripe for each automatic controller.
- B. Wire Trench: Wiring shall occupy the same trench and shall be installed along the same route as pressure supply of lateral lines wherever possible. Where more than one wire is placed in a trench, the wires shall be taped together at intervals not exceeding ten feet.
- C. Expansion Curl: 24" minimum length expansion curl should be provided at each remote control valve, within three feet of each wire connection and at least at every one hundred feet of wire length.
- D. Wire Splices: All splices shall be made with Spears "Dri-Splice Wire Connector", Model No. DS-400, 3M " DBY-Direct Bury Splice Kit", or approved equal. Splice connectors shall be prefilled by manufacturer with silicon sealant. Use one splice per connector, install as per manufacturer's specifications.

2.03 Gate Valves: Gate Valves 3" or Smaller shall conform to the following:

- o Rated: 125-pound saturated steam, 200-pound cold water, oil, gas
- o Brass or bronze body, ASTM-B62, with screwed ends
- o Non-rising brass stem, ASTM-B16
- o Screwed brass or bronze bonnet, ASTM-B62
- o Brass or bronze disc, ASTM-B62
- o Equipped with cast iron handwheel, ASTM-A126

2.04 Remote Control Valves, Electrical

- A. Electric remote control valves shall be as per drawings. They shall be designed for a 24 volt, 60 cycle system, accurately machined valve seat surfaces, equipped for flow control adjustment, and with the capability for manual operation. They shall be readily disassembled for repair and the internal parts shall be easily accessible for service even when installed in the line. Valve shall be a normally closed, diaphragm type with slow opening and closing action as protection against surge pressures. Actuation shall be by an encapsulated type solenoid with the solenoid shuntband, tube, and plunger of stainless steel for corrosion protection.

2.05 Valve Boxes

- A. Gate Valves: Gate valves shall be installed in round Brooks 1100 Series, 10" diameter x 10" valve box, with green, bolt-down lid, or an approved equal, with Schedule 40 PVC Riser Pipe, 10 inch diameter with length as required to extend valve box from bottom of gate valve to finish grade as per drawings.

- B. Remote Control Valves: Remote control valves shall be installed in Brooks 1419 Series, 12" x 17" box with a green bolt-down cover, and Brooks 1419 Series extensions as required to bring top of box up to finish grade as per drawings shall be provided, or an approved equal.
- C. Quick Coupler Valves: Quick couplers shall be installed in round Brooks 1100 Series, 10" diameter x 10" valve box, with green, bolt-down lid, or an approved equal, with Schedule 40 PVC Riser Pipe, 10 inch diameter with length as required to extend valve box from swing joint to finish grade as per drawings.

2.06 Irrigation Heads:

- A. All irrigation heads shall be new, of the same size, type, and deliver the same rate of precipitation with the diameter (or radius) of throw, pressure, and discharge as shown on the drawings and/or specified herein, or approved by Architect.
- B. Spray and rotor heads shall have a nozzle radius/flow screw adjustment.

PART 3 - INSTALLATION PROCEDURES

3.01 Trenches

- A. Dig trenches straight and support pipe continuously on bottom of trench. Lay pipe to an even grade. Trenching excavation shall follow layout on Drawings and as noted. Burial depths as follows:
 - o Pressure supply lines - 2-1/2" and smaller: 18" minimum
 - o Non pressure lines: 12" minimum.
 - o Control wire: 18" minimum
 - o Drip tubing and Netafim tubing: 4"

3.02 Backfill

- A. Contractor shall not allow or cause any work installed by him to be covered before it has been inspected, and approved by the Owner/Landscape Architect. Work covered before approval shall be uncovered at Contractor's expense.
- B. Pressure mainline pipe trenches shall not be backfilled until all required tests are performed, and approved by Owner/Landscape Architect.
- C. Backfill trenches carefully with approved materials, free from clods of earth or stones one inch or larger. Sand bedding material backfill shall be installed on bottom and sides of pipe at three inches minimum depth, twelve (12) inches minimum depth of top cover where native soils contain greater than 30% rocks or other material one inch or larger in diameter, or as directed by Owner/Landscape Architect. Mechanically compact backfill to a dry density equal to adjacent undisturbed soil and conforming to adjacent surface grades without irregularities.
- D. All unapproved backfill material installed shall be removed at Contractor's expense.
- E. If settlement occurs and subsequent adjustments in pipe, valves, sprinklers heads, lawn or planting, or other construction are necessary, the contractor will make all the required adjustments without cost to the Owner.

3.03 PVC Pipe Installation

- A. The Contractor shall exercise care in handling, loading, unloading and storing of PVC pipe and fittings. All PVC pipe shall lie flat so as not to subject it to undue bending or concentrated external load at any point. Any section of pipe that has been dented or damaged will be discarded and, if installed, shall be replaced with new piping at Contractor's own expense. Do not store pipe and fittings in direct sunlight.
- B. Thoroughly clean PVC pipe and fittings of dirt, dust and moisture before installation.
- C. Installation and solvent welding methods shall be as recommended by the pipe and fitting manufacturer. On PVC to metal connections the Contractor shall work the metal connections first. Use Teflon tape, or approved equal, on all threaded PVC, and on all threaded PVC to metal joints. Light wrench pressure is all that is required. No pipe dope or liquid PVC products shall be used. Where threaded PVC connections are required, use threaded PVC adapters into which the pipe may be welded. Install no multiple assemblies (manifolds) on plastic lines. Provide each assembly with its own outlet.
- D. In changing pipe depth, 45 degree elbows shall be used.

3.04 Pipe Clearance

- A. All lines shall have a minimum clearance of six inches from each other. Do not install parallel lines directly over one another.

3.05 Testing

- A. Test all pressure lines, and all non-pressure lines under pavement with a hydrostatic pressure of 125 P.S.I. Test all non-pressure lines under existing static pressure. Sustain pressures in lines for not less than four hours, and prove watertight. If leaks develop, replace joints, and repeat test until entire system is proven watertight. Testing of pressure main lines shall occur prior to installation of electric control valves.
- B. Verify pressure in field at each point of connection (POC) from municipal water supply, or project potable water supply.

3.06 Head Installation:

- A. Prior to the installation of irrigation heads, the system must be thoroughly flushed to the complete satisfaction of the Owner/Landscape Architect. Spacing of irrigation heads shall not exceed the maximum indicated on the drawings. In no case shall the spacing exceed the maximum recommended by the manufacturer. Set all sprinkler heads perpendicular to finished grades unless otherwise designated on the plans.

3.07 Riser/swing joint assemblies

- A. Fabricate in accordance with the details on drawings. Riser nipples for all irrigation heads shall be the same size as the riser opening in the sprinkler body.

3.08 Existing Trees

- A. Where it is necessary to excavate adjacent to existing trees, the Contractor shall use all possible care to avoid injury to trees and tree roots. Excavation in areas where 1" and larger roots occur shall be done by hand. All roots 1" and larger in diameter shall be tunneled under and shall be heavily wrapped with burlap to prevent scarring or excessive drying. Where a ditching machine is run close to trees having roots smaller than 1" in diameter, the wall of the trench adjacent to the tree shall be hand trimmed, making clean

cuts through. Roots 1" and larger in diameter shall be painted with two coats of Tree Seal or equal. Trenches adjacent to trees should be closed within 24 hours; and where this is not possible, the side of the trench adjacent to the tree shall be kept shaded with burlap or canvas.

3.09 Clean-Up

- A. Clean-up shall be made as each portion of work progresses. Refuse and excess dirt shall be removed from the site, all walks and paving shall be broomed or washed down, and any damage sustained to the work of others shall be repaired to original conditions.

3.10 Irrigation Control Wire Splicing

- A. Splices of irrigation control wires other than those required directly in remote control valve boxes for that specific valve shall be not made. Exceptions to this may be made, with the Landscape Architect's prior approval, if the installation of landscape work is to be phased in several phases, or other substantial extenuating circumstances. In all instances, all control wire splices must be made per these specifications and details, and all splices must be placed within a remote control valve box, or a similar box just for splicing.

END OF SECTION

**SECTION 32 91 20
LANDSCAPING REPAIR**

PART 1 - GENERAL

1.01 Scope of Work:

- A. The Contractor shall provide all labor, materials, transportation and services necessary to furnish and install all work associated with restoring existing landscape areas and plant materials damaged as the result of work under this contract.

1.02 Quality Assurance:

- A. All work shall be performed by a C-27 California licensed Landscape Contractor.
- B. Plants shall be subject to inspection and approval of Owner/Architect upon delivery for conformity to specifications. Such approval shall not impair the right of inspection and rejection during progress of the work.

1.03 Site Verification:

- A. Prior to commencement of work, the Contractor shall verify, at the site, all conditions and dimensions shown on the plans necessary to achieve the intended planting. Any discrepancies shall be reported to the Owner/Architect immediately.

1.04 Coordination:

- A. The Landscape Contractor shall be responsible for coordination of his activities with all other trades through the Owner and General Contractor.

1.05 Written Guarantee:

- A. Contractor shall guarantee all turf and plants in writing, on his letterhead, to live in a healthy condition for one year after planting. Contractor shall replace dead or unhealthy turf and plants immediately. All replacements shall be as originally specified, without cost to the Owner.

1.06 Product Delivery, Storage, and Handling:

- A. All seed shall be labeled and furnished in sealed standard containers.
- B. Turf Grass Sod shall be protected during delivery from desiccation. Storage of sod at job site shall be minimized; sod shall be covered and/or wetted down as required to prevent damage.
- C. Deliver plants with legible identification labels.
- D. Protect plant material during delivery to prevent damage to rootball, desiccation of foliage, or damage to leader.
- E. Store plant material in shade and protect from weather.
- F. Maintain and protect plant material as required for optimum health.

1.07 Submittals:

- A. Contractor shall furnish a list of all proposed turf and plant materials proposed for the project including botanical names and growth characteristics of each species for approval by the Owner/Architect.

PART 2 - MATERIALS

2.01 General

- A. All materials shall be standard, approved, first grade quality, and in prime condition when installed and accepted. Any commercially processed or packaged material shall be delivered to the site in the original unopened container bearing the manufacturer's guaranteed analysis. Contractor shall Owner with a sample of all supplied materials accompanied by analytical data from an approved laboratory source illustrating compliance or bearing the manufacturer's guaranteed analysis.

2.02 Amendments and Fertilizers: Amendments and fertilizers shall be equal to the following minimum criteria and in accordance with soils report recommendations.

- A. General Fertilizer: (For plant materials) "6-20-20 XB" by Simplot/Best, or an approved equal, consisting of the following percents by weight:

- 6% nitrogen
 - 20% phosphoric acid
 - 20% potash

- B. Turf Grass Lawn Fertilizer: (For turf grass) "Turf Supreme" by Simplot/Best, or an approved equal, consisting of the following percents by weight:

- 16% nitrogen
 - 6% phosphoric acid
 - 8% potash

2.03 Plants: All plants shall meet, as specified in the plans, the following minimum requirements

- A. Quality: All plants shall be in accordance with the California State Department of Agriculture's regulation for nursery inspections, rules and grading. All plants shall have normal habit of growth and shall be sound, healthy, vigorous and free of insect infestations, plant diseases, sun scalds, fresh abrasions of the bark or other objectionable disfigurements. Tree trunks shall be sturdy and will hardened off. Trees, and any shrubs specified as standard shall have straight, single trunks, unless otherwise specified on the drawings. Those trees/shrubs specified to be multi-trunk shall have at least leaders from the base. All plants shall have normally well-developed branch systems, and vigorous and fibrous root systems which are not root or pot bound. At no time shall trees or plant materials be pruned, trimmed, or topped prior to delivery, and any alteration of their shape shall be conducted only with the approval, and when in the presence of the Owner/Landscape Architect. All plants shall be grown under climatic conditions similar to those in locality of the project. All inspection certificates required by law shall accompany each shipment and be delivered to the Owner.
- B. Size: The size of the plants will correspond with the American Standard for Nursery Stock and with that normally expected for species and variety of commercially available nursery stock, or as specified in the drawings. Plants larger in size than specified in the drawings may be used with the approval of the Owner, but the use of larger plants will make no change in contract price.

- C. Name: All plants shall be true to name as specified on drawings, and tagged with one label per every five plants or plant containers with the correct plant botanical name and common name in accordance with the standards of practice recommended by the American Association of Nurserymen. Label shall utilize water-resistant ink which will remain legible for at least sixty (60) days from date of delivery to job site.
- D. Rejection or Substitution: All plants not conforming to the requirements herein specified, shall be considered defective, and such plants, whether in place or not, shall be marked as rejected and immediately removed from the site of the work and replaced with new plants at the Contractor's expense. The plants shall be of the species, variety, size and condition/habit specified on the drawings. Under no condition will there be any substitution of plants or sizes for those listed on the accompanying plans, except with the expressed consent of the Owner.

2.04 Topsoil

- A. Topsoil shall consist of a natural, fertile, friable, sandy loam soil possessing the characteristics of representative soils in the vicinity which produce heavy growth of crops, grasses or other vegetation and shall be obtained from natural well-drained areas. Before removal of the topsoil, the surface at the source of supply is to be stripped to a depth of two inches in order to remove weed seeds, roots, needle mat, etc. The source of topsoil shall be free from Bermuda grass, crab grass and all noxious weeds or grasses. The topsoil shall be free from sub-soil, refuse, heavy roots, clay lumps, stones larger than one inch in size, noxious weeds, sticks, brush, litter and other deleterious substances.

2.05 Sod

- A. Sod shall be fully mature, well maintained, of the grass variety specified in the drawings or these specifications, free of all other grasses or weeds, and shall be evenly cut with a conventional sod cutting machine to a thickness of 1-1/2 to 2 inches. All material shall be obtained from the same growing ground and delivered fresh to the job site; within twenty-four (24) hours of cutting. Protect sod from drying out during transportation and storage at job site.

2.06 Bark Mulch

- A. Bark mulch shall be "walk-on" type which forms an interlocking medium texture resistant to wind-blown movement, and erosion.

2.07 Wood Headerboards

- A. All wood used in construction of headerboards shall be construction heart redwood grade or better.
- B. Headerboards shall be 2" x 4". Splices shall be made with 1" x 4" and shall not be less than 12" in length. Stakes shall be placed at intervals of not more than five (5) feet on center, and shall be 2" x 2" x 18". All stakes shall be set below top of headerboard and stake tops cut with bevel cut after driving.
- C. On sharp turns, and curbs, four 1/2" x 4" laminated boards, or two 1" x 4" laminated boards may be permitted. Minimum width for headerboard shall be 1-1/2", typical.
- D. Stakes and splices shall be nailed with galvanized common nails as per drawings. Nail as required for solid installation.

- E. Headerboards shall be furnished as shown on the drawings and herein specified. They shall be laid true to line and grade, and in a workmanlike manner. Care shall be exercised in laying wood headers to protect adjacent improvements, shrubbery and other properties from damage. All stakes shall be placed on ground cover side of headerboard.

PART 3 - INSTALLATION

3.01 Site Preparation

- A. The Contractor shall remove all weeds, debris and all deleterious materials such as aggregate base rock, construction debris, asphalt paving, concrete over-pour, trash, limed soil, and native surface stones greater than two (2) inches in diameter from all planted areas in project site prior to proceeding with any work under this contract. The Contractor shall dispose of all removed materials in a suitable, and lawful manner.

3.02 Finish Grading

- A. The Landscape Contractor shall be responsible for installation of any additional topsoil backfill from an approved source in all planted areas as required to achieve finish grade and provide proper surface drainage from rough grade described above.
- B. Soil shall be floated to a smooth and even surface conforming to specified grades after settlement has occurred. Finish grade in seeded turf areas shall be 1" below adjacent hardscape. Finish grade in shrub/ground cover areas and sod turf areas shall be 2" below adjacent hardscape. All changes in grade and grades at the limit of work shall be blended to obtain smooth, even transitions and eliminate abrupt change. Finish grade shall be approved by the Owner/Landscape Architect prior to soil preparation.

3.03 Soil Preparation

- A. Turf Areas: After approximate finish grades have been established, all new turf planted areas shall receive the following amendments uniformly blended into the upper 6" of surface soil per 1,000 square feet.
 1. 5 cubic yards organic amendment (nitrogen stabilized redwood, fir, or cedar sawdust).
 2. 250 pounds Gro-Power Plus Fertilizer.
 3. Soil conditioners per soils report.
 4. 30 pounds of General Fertilizer (6-20-20)
- B. All planted areas: Any soil in planted areas which had lime added to it during grading or other construction must be excavated fully, and disposed off-site. All local, State, and Federal codes shall be strictly followed in disposal of limed soil. Landscape Contractor shall verify with all of the following that lime was, or was not, used in treating any soil, and the locations of such treatment: Project Architect, Landscape Architect, General Contractor. Landscape Contractor shall provide in his price quotation schedule a line item for removal and disposal of lime treated soil on a per cubic yard basis.

3.04 Irrigation

- A. No planting shall take place until the entire irrigation system is under full automatic operation for a minimum period of seven days. All soil areas shall be moistened and settled by application of irrigation. Minimum moisture penetration depth of twelve (12) inches.

3.05 Planting: All plant material shall be as specified and planted as detailed and noted herein.

- A. Excavation shall include the stripping and stacking of all acceptable topsoil encountered within the areas to be excavated for plant pits.
- B. Excavated Shape: Vertical sides, and flat bottom. Plant pits to be square for box materials; circular for canned material. Scarify sides and bottom of each pit to remove all shovel or blade polish.
- C. Pit Size: All trees, and shrubs shall have planting pits dug three times the diameter of the root ball. Pit depth shall be as per details on drawings. In no instance shall plants be planted with top of original rootball lower than finish grade.
- D. Protect all areas from excessive compaction when trucking plants, or other materials to planting site.
- E. Can Removal: Pry gently to widen plastic container in several places; tap to loosen. Do not injure the rootball. Do not pull on trunk or pick up plant by trunk as this may damage root system. Carefully grasp rootball and remove plants without injury or damage to root ball. After removing plant from container and placing in planting pit, carefully loosen by hand roots on rootball side surfaces and direct outward and downward.
- F. Face plants with fullest growth into prevailing wind.
- G. Center plant in pit. Verify correct pit depth. Set plant plumb, and hold rigidly in position until backfill has been tamped firmly by hand or foot around rootball. Backfill with backfill mix in layers, tamping each layer. Water thoroughly.
- H. Temporary Watering Basin: After backfilling, an earthen basin shall be constructed around each plant. Each basin shall be of a depth sufficient to hold at least two inches of water. Basin shall be of a size suitable for the individual plant. In no case shall the basin for fifteen gallon plant be less than four feet in diameter; a five-gallon plant less than three feet in diameter. The basins shall be constructed of backfill mix material, and shall not be constructed for trees in turfgrass areas. See details on drawings.
- I. Pruning shall be only as directed by the Landscape Architect. Direction and approval is required prior to any pruning taking place, and not before plants have been inspected and approved. Plants which have been pruned otherwise shall be replaced at contractors expense.

3.06 Handling/Storage

- A. All plants shall be handled and stored so they are adequately protected from drying out, sunburn, windburn or any other injury, or from vandalism or theft. Do not drop plant materials. Do not pick up container plant material by stem or trunks.

3.07 Rejection of Plant Material

- A. The Owner/Landscape Architect may reject any and all plant material regarded as unsuitable at any time. Such plants shall be removed from the job site at once and replaced at no additional cost to the Owner.

3.08 Planting Tablets

- A. 21-gram Agriform, or approved equal, plant tablets shall be placed adjacent to (2" + from the rootball), but not in contact with the rootball in the plant pit at one-third the depth of the rootball at the following rate:
 - 1. One tablet per one gallon container.
 - 2. Two tablets per five gallon container.
 - 3. Three tablets per fifteen gallon container.
 - 4. Six tablets per box specimen.

3.09 Ground Cover Planting

- A. All ground cover areas noted on the plans shall receive rooted cuttings from flats and shall be planted in staggered rows with triangular spacing individual plants continuously under all trees and shrubs at the spacing indicated on the plans. All spacings specified are the maximum allowable. The first row (next to curb, foundation, etc.) shall be one-half the specified spacing. All plants shall be protected from drying out prior to planting. Care shall be exercised at all times to protect the plants after planting. Any damage to plants by trampling, or other operations of this Contract shall be repaired immediately.

3.10 Vines

- A. All vines shall have the wood support stake carefully removed without damage to the plant or rootball. All vines shall be attached to wood walls with eye-screws and "heavy-duty" plastic ribbon ties, or to masonry walls with glue-on vine ties as necessary (5 ties minimum).

3.11 Watering

- A. Immediately after planting, apply water to each tree and shrub by means of a hose. Apply water in a moderate stream to the planting hole until the backfill mix and rootball is completely saturated. Use irrigation system to thoroughly water ground cover.

3.12 Bark Mulch

- A. Mulch shall be installed uniformly covering non-seeded, and non-turf planted areas to depth specified on drawings.

3.13 Turf Grass

- A. Preparation: Following fine grading and soil preparation, the areas to be planted to lawn shall be rolled, raked and floated to finish grade by any acceptable method with the finish grade being smooth and even, free of rocks over ½" diameter, debris and clods, and reasonably well firmed. Prior to planting, the surface of the area shall be sufficiently loose and friable to receive the sod.

PART 4 - MAINTENANCE

4.01 Maintenance Period

- A. The maintenance period shall commence time upon the Owner/Architect's written approval of all phases of planting span installation and shall be for 90 days. Seed installations shall be observed and checked regularly for proper germination and setting of new seed.

4.02 Maintenance Procedures

- A. General: The general care and maintenance of all areas shall consist of proper watering, fertilization, weeding, and clean-up to maintain all plants and turf in a healthy, growing condition as noted below.

- B. Watering

- 1. Properly and completely maintain all irrigation systems, clean all lines, valves, heads and other portions of such systems to assure their continual proper operations. Lubricate as needed.
- 2. Program controller on a weekly basis considering weather, the water requirements of each sectional valve, and the application rate of each area is capable of receiving, without runoff.

- C. Fertilization: Maintenance work shall include fertilization; fertilizer at 30-day intervals as noted herein.

- 1. Turf Grass: 5 lbs./1000 sf. Fertilizer 16-6-8.
- 2. Ground Covers/Shrubs: 5 lbs./1000 sf. Fertilizer 16-6-8.

- D. Mow Turf: Edge and mow to a height of 2 inches whenever the turf reaches a height of 3 inches. Grass clippings shall be removed off-site. Mowing shall be scheduled around school use hours. Mowing shall not be done during soil moisture saturated conditions. All wheel ruts, and depressions shall be repaired by Landscape Contractor at his expense.

4.03 Replacement

- A. Replanting: Immediately replace any and all plant materials which for any reason are damaged or die during the maintenance period. Replace as originally specified. The Owner/Landscape Architect shall be the sole judge as to the condition of plant material.

4.04 Protection

- A. Protect all planting against damage, including erosion, rodents, and trespass, providing proper safeguards as needed. Repair damage to the work made by pedestrians, animals, vehicular traffic, or any other cause until acceptance.

4.05 Irrigation

- A. All irrigation must be operating and programmed properly for efficient coverage and minimum over-spray at the end of the maintenance period.

4.06 Final Acceptance

- A. Will be given at the end of the maintenance period for all planted areas once plant establishment has been obtained. All plants must be in a healthy, growing condition as approved by the Owner/Landscape Architect.

END OF SECTION

MT. DIABLO HIGH SCHOOL BUILDING - S SCIENCE LAB MODERNIZATION

2450 Grant Street
Concord, California 94520

MOUNT DIABLO UNIFIED SCHOOL DISTRICT

--- CONSTRUCTION DOCUMENT SUBMITTAL --- FEBRUARY 19, 2013

ONE AND ONE-HALF INCH = ONE FOOT
ONE INCH = ONE FOOT
THREE-QUARTERS INCH = ONE FOOT
ONE-HALF INCH = ONE FOOT
ONE-QUARTER INCH = ONE FOOT
ONE-EIGHTH INCH = ONE FOOT
ONE-SIXTEENTH INCH = ONE FOOT
ONE INCH = TWENTY FEET

Mt. Diablo High School
Building S - Science Lab Modernization
2450 Grant Street
Concord, California 94520
Mt. Diablo Unified School District

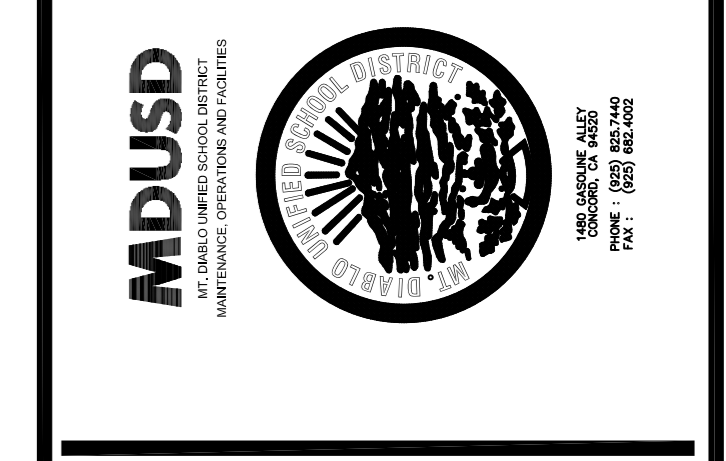

FILE NO. XX-XX
IDENTIFICATION STAMP
DIV. OF THE STATE ARCHITECT
OFFICE OF REGULATION SERVICES
APPLICATION NO. 01-
AC. FLS. SS
DATE

DIVISION OF THE STATE ARCHITECT
revision date: by:

CONSULTANT
nacht&lewis
600 Q Street, Suite 100
Sacramento, CA 95811
www.nachtlewis.com
916.329.4000

ARCHITECT
REVISIONS

NO.	DESCRIPTION	DATE	REV

DATE February 19, 2012
JOB NO. Y1211.00
SHEET TITLE
Title Sheet
SHEET NO.
TO
SHEET ___ OF TOTAL
DSA SUBMITTAL SET

ABBREVIATIONS	PROJECT TEAM
	OWNER: MOUNT DIABLO UNIFIED SCHOOL DISTRICT 3333 RONALD WAY CONCORD, CA 94521 PHONE: (925) 682-8000, EXT. 85615 CONTACT: TIM COOY
	ARCHITECT: NACHT & LEWIS ARCHITECTS 600 Q STREET, SUITE 100 SACRAMENTO, CALIFORNIA 95811 PHONE: (916) 325-4000 CONTACT: BRIAN MAYTUM
	STRUCTURAL ENGINEER: BARRIEV PELHAM & ASSOCIATES, INC. 3001 E STREET SACRAMENTO, CA 95816 PHONE: (916) 418-9100 CONTACT: JASON SCANLAN
	MECHANICAL ENGINEER: CAPITAL ENGINEERING CONSULTANTS, INC. 11020 SUN CLOVER DRIVE RANCHO CORDOVA, CA 95670 PHONE: (916) 851-3500 CONTACT: WIRE MINGE
	ELECTRICAL ENGINEER: HARRY A. YEE & ASSOCIATES, INC. 4920 FREEMONT BLVD., SUITE D SACRAMENTO, CA 95822 PHONE: (916) 454-5319 CONTACT: DAVID YU

ABBREVIATIONS	PROJECT TEAM
	SYMBOLS LEGEND
	SEE INDIVIDUAL SHEETS FOR ADDITIONAL SHEET SPECIFIC SYMBOLS & LEGENDS NOT INDICATED HERE
	ROOM NO. ROOM NAME
	GAUGE
	COLUMN LINE
	SECTION
	DETAIL
	EXTERIOR ELEVATION
	INTERIOR ELEVATION
	OPENING
	MATCH LINE
	DATUM
	REVISION
	NEW DOOR
	EXISTING DOOR
	EXISTING DOOR TO BE REMOVED
	EXISTING WORK TO BE REMOVED
	NEW WALL CONSTRUCTION

- GENERAL NOTES**
- CONTRACTOR SHALL FIELD VERIFY ALL DIMENSIONS AND EXISTING CONDITIONS AT THE SITE AND SHALL REPORT ANY DISCREPANCIES IN WRITING TO THE ARCHITECT OR CONSTRUCTION MANAGER BY MEANS OF A REQUEST FOR INFORMATION (RFI) OR AS PART OF THE APPLICABLE SHOP DRAWING/SUBMITTAL.
 - SPECIFIC ITEMS NOTED TO BE VERIFIED OR FIELD VERIFIED ARE REQUIRED TO BE REVIEWED AND DOCUMENTED BY THE CONTRACTOR PRIOR TO GENERATING SHOP DRAWINGS, SUBMITTALS AND/OR ORDERING MATERIALS.
 - CONTRACTOR IS RESPONSIBLE FOR ALL INCIDENTAL WORK NECESSARY TO COMPLETE THE INSTALLATION OF THE NEW WORK. THIS INCLUDES, BUT IS NOT LIMITED TO, THE REMOVAL AND/OR REINSTALLATION OF ALL EXISTING ITEMS, OR PORTIONS OF THE EXISTING CONSTRUCTION WHETHER SHOWN IN THESE DRAWINGS OR NOT.
 - THE EXISTING FACILITY HAS ASBESTOS CONTAINING MATERIAL IN VARIOUS LOCATIONS. ANY PART OF THE WORK REQUIRING REMOVAL OF ASBESTOS CONTAINING MATERIAL SHALL BE PERFORMED IN ACCORDANCE WITH THE ASBESTOS ABATEMENT SPECIFICATIONS IN THE PROJECT MANUAL.
 - THE EXISTING FACILITY HAS LEAD CONTAINING MATERIAL IN VARIOUS LOCATIONS. ANY PART OF THE WORK REQUIRING REMOVAL OF LEAD CONTAINING MATERIAL SHALL BE PERFORMED IN ACCORDANCE WITH THE LEAD ABATEMENT SPECIFICATION IN THE PROJECT MANUAL.
 - THE EXISTING FACILITY HAS PCB BALLASTS AND FLUORESCENT TUBE MATERIALS IN VARIOUS LOCATIONS. ANY PART OF THE WORK REQUIRING REMOVAL OF PCB BALLAST AND FLUORESCENT TUBE MATERIALS ABATEMENT SPECIFICATIONS IN THE PROJECT MANUAL.
 - CONTRACTOR SHALL BE RESPONSIBLE FOR PROTECTION, MODIFICATION AND REINSTALLATION OF ALL EXISTING ROOFTOP PIPING, CONDUIT, WIRE AND EQUIPMENT DURING ANY REQUIRED ROOF REMOVAL AND/OR REPLACEMENT OPERATIONS.
 - PRIOR TO SITE MOBILIZATION, ALL PRIME CONTRACTORS, THE CONSTRUCTION MANAGER AND PROJECT INSPECTOR ARE TO MEET ON SITE AND PHOTO DOCUMENT THE EXISTING CONDITIONS OF THE CONTRACTORS CORPORATION YARD AREA AND LANDSCAPED AREAS WHERE TRENCHING WILL BE OCCURRING OR WHERE VEHICLE TRAFFIC IS ANTICIPATED. ALSO TEST IRRIGATION SYSTEM FOR PROPER OPERATION. AT PROJECT COMPLETION ALL AREAS MUST BE RESTORED TO ORIGINAL CONDITION INCLUDING BUT NOT LIMITED TO INSTALLING SOD AT DAMAGED TURF AREAS, REPLACING DAMAGED PLANTINGS, REPAIRING DAMAGED UNDERGROUND UTILITIES, PATCHING DAMAGED ASPHALT PAVING, RE-STRIPPING PAVING OR REPLACEMENT OF DAMAGED CONCRETE. ALL PRIME CONTRACTORS, THE CONSTRUCTION MANAGER AND PROJECT INSPECTOR SHALL MEET ON SITE AT PROJECT COMPLETION AND REVIEW ALL SITE CONDITIONS AND OPERATION OF IRRIGATION SYSTEM.
 - ALL PRIME CONTRACTORS ARE RESPONSIBLE TO HAVE EMERGENCY SHUT-OFF PROCEDURES IN PLACE PRIOR TO START OF CONSTRUCTION. EACH PRIME SHALL FAMILIARIZE THEMSELVES WITH ALL SHUT-OFF VALVE LOCATIONS ON SITE AND HAVE PROPER TOOLS READILY AVAILABLE TO OPERATE VALVES.
 - ALL WORK, MATERIAL, METHODS, ETC. SHALL CONFORM TO ALL GOVERNING BUILDING CODES, REGULATIONS AND AGENCIES.
 - THE GENERAL CONTRACTOR SHALL BE RESPONSIBLE FOR ASSURING THAT ALL NECESSARY PERMITS AND APPROVALS ARE OBTAINED PRIOR TO BEGINNING WORK OR ORDERING MATERIALS.
 - ANY CONFLICT WITH THESE PLANS AND EXISTING CONDITIONS SHALL BE BROUGHT TO THE IMMEDIATE ATTENTION OF THE ARCHITECT.
 - ALL WORK SHALL BE IN COMPLETE CONFORMANCE WITH MANUFACTURER'S SPECIFICATIONS AND RECOMMENDATIONS OR AS OTHERWISE OUTLINED IN THE SPECIFICATIONS.
 - CONTRACTOR TO COORDINATE WITH EQUIPMENT SUPPLIERS FOR POWER REQUIREMENTS, BLOCKING LOCATIONS, SUPPORT FOR EQUIPMENT, PLUMBING REQUIREMENTS AND ROUGH-IN LOCATIONS.
 - WHERE INCLUDED IN THESE DRAWINGS, "KEYNOTES" DENOTE WORK TO BE PERFORMED UNDER THIS CONTRACT AND ARE IDENTIFIED ON EACH SHEET. NOT ALL "KEYNOTES" MAY BE USED ON EACH SHEET. "GENERAL SHEET NOTES" DENOTE DESCRIPTIONS OF ADDITIONAL NEW WORK SPECIFIC TO THE SHEET CONTAINING THE "GENERAL SHEET NOTES".
 - USE OF ANY NEW MATERIAL CONTAINING ASBESTOS IS PROHIBITED.
 - DETAILS, MATERIALS, AND FINISHES ARE TYPICAL FOR ALL SIMILAR CONDITIONS UNLESS NOTED OTHERWISE.
 - THE TERM "TYPICAL" (TYP) SHALL BE CONSTRUED TO MEAN APPLYING TO ALL LIKE OR SIMILAR CONDITIONS IN THE AREAS DESIGNATED FOR WORK SCOPE (I.E. WITHIN THE BOUNDARIES OF THIS PROJECT).
 - NOT ALL CEILING APPURTENANCES (SMOKE DETECTORS, EXHAUST FANS, ACCESS DOORS, ETC.) ARE SHOWN. CONTRACTOR TO FIELD VERIFY AND TAKE APPROPRIATE ACTION TO ACCOMMODATE THESE ITEMS.
 - ALL DEMOLISHED ITEMS SHALL BE REMOVED FROM THE SITE AND DISPOSED OF PROPERLY AND LEGALLY.
 - PRIOR TO STARTING ANY WORK, THE CONTRACTOR SHALL CONDUCT A SURVEY, WITH A DESIGNATED DISTRICT REPRESENTATIVE, TO DETERMINE THE OPERABILITY OF ALL EXISTING MECHANICAL, TELEPHONE AND INTRUSION ALARM SYSTEMS. THE DISTRICT'S REPRESENTATIVE WILL PROVIDE A WRITTEN REPORT TO THE CONSTRUCTION MANAGER AND TO THE CONTRACTOR TO INSURE THE SAME OPERABILITY OF THESE COMPONENTS AT THE COMPLETION OF THE PROJECT.
 - ALL ITEMS THAT ARE LABELED "CONCURRENT", "NIC", OR "EXISTING" ARE NOT PART OF THIS APPLICATION AND ARE NOT PART OF THE DSA APPROVAL FOR THIS PACKAGE.
 - A COPY OF THE CALIFORNIA BUILDING CODES PARTS 1, 2, 3, 4 AND 5, TITLE 24, C.C.R. SHALL BE KEPT ON THE JOB SITE AT ALL TIMES.
 - ALL CHANGE ORDERS AND ADDENDA SHALL BE SIGNED BY THE ARCHITECT AND OWNER AND APPROVED BY DSA. CHANGE ORDERS ARE NOT VALID UNTIL APPROVED BY DSA (4-338) PART 1, TITLE 24, C.C.R.
 - ALL TESTS SHALL CONFORM TO THE REQUIREMENTS OF SECTION 4-335, TITLE 24, C.C.R. AND APPROVED TEST & INSPECTIONS (T&I) SHEETS.
 - TESTS OF MATERIALS AND TESTING LAB SHALL BE IN ACCORDANCE WITH SECTION 4-335 OF TITLE 24 AND THE DISTRICT SHALL EMPLOY AND PAY THE LAB. COSTS OF RE-TEST MAY BE BACK CHARGED TO THE CONTRACTOR.
 - DSA SHALL BE NOTIFIED AT THE START OF CONSTRUCTION AND PRIOR TO THE PLACEMENT OF CONCRETE, PER SECTION 4-331.
 - INSPECTOR SHALL BE APPROVED BY DSA. INSPECTION SHALL BE IN ACCORDANCE WITH SECTION 4-333(b). THE DUTY OF THE INSPECTOR SHALL BE IN ACCORDANCE WITH SECTION 4-342.
 - SUPERVISION OF CONSTRUCTION BY DSA SHALL BE IN ACCORDANCE WITH SECTION 4-334.
 - CONTRACTOR, INSPECTOR, ARCHITECT AND ENGINEERS SHALL SUBMIT VERIFIED REPORTS (SSS-6) IN ACCORDANCE WITH SECTIONS 4-336 AND 4-343 OF TITLE 24.
 - THE ARCHITECT AND STRUCTURAL ENGINEER SHALL PERFORM THEIR DUTIES IN ACCORDANCE WITH SECTIONS 4-333(i) AND 4-341.
 - THE CONTRACTOR SHALL PERFORM HIS DUTIES IN ACCORDANCE WITH SECTION 4-343.
 - THE INTENT OF THESE DRAWINGS AND SPECIFICATIONS IS THAT THE WORK OF THE ALTERATION, REHABILITATION OR RECONSTRUCTION IS TO BE IN ACCORDANCE WITH TITLE 24, CALIFORNIA CODE OF REGULATIONS (C.C.R.). SHOULD ANY EXISTING CONDITIONS SUCH AS DETERIORATION OR NONCOMPLYING CONSTRUCTION BE DISCOVERED WHICH IS NOT COVERED BY THE CONTRACT DOCUMENTS WHEREIN THE FINISHED WORK WILL NOT COMPLY WITH TITLE 24, C.C.R., A CHANGE ORDER, OR A SEPARATE SET OF PLANS AND SPECIFICATIONS, DETAILING AND SPECIFYING THE REQUIRED REPAIR WORK SHALL BE SUBMITTED TO AND APPROVED BY DSA BEFORE PROCEEDING WITH THE REPAIR WORK.

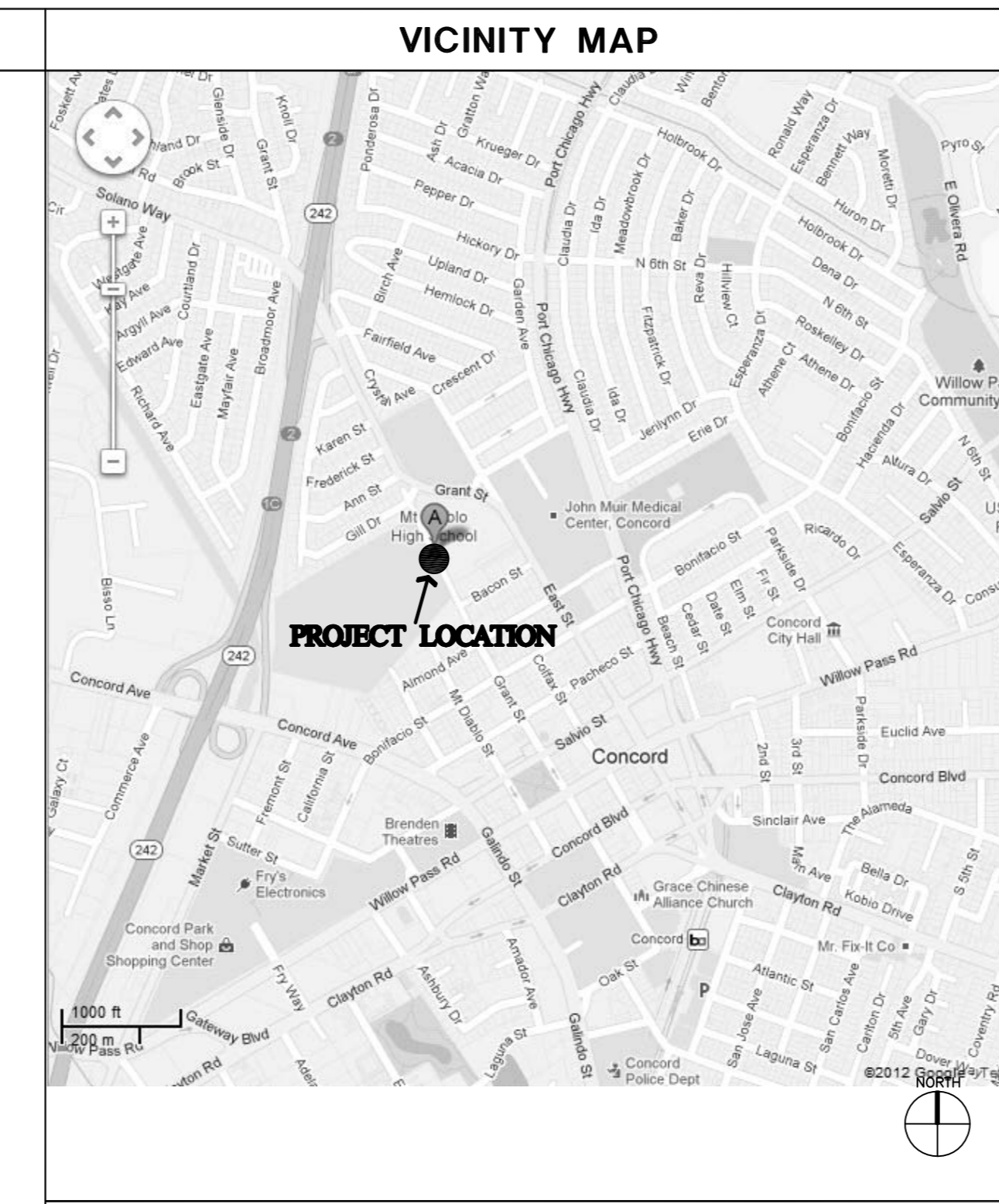

SHEET INDEX

TO	TITLE SHEET
ARCHITECTURAL:	
A1.0	OVERALL SITE PLAN
A1.1	ENLARGED SITE PLAN
A1.2	ENLARGED PAVING PLAN
A1.3	SITE DETAILS
A2.0	BUILDING DEMOLITION PLAN
A3.0	PARTIAL FLOOR PLAN - EAST
A3.1	PARTIAL FLOOR PLAN - WEST
A4.0	PARTIAL REFLECTED CEILING PLAN - EAST
A4.1	PARTIAL REFLECTED CEILING PLAN - WEST
A5.0	ROOF PLAN
A6.0	PARTIAL FLOOR FINISH MARKING PLAN - EAST
A6.1	PARTIAL FLOOR FINISH MARKING PLAN - WEST
A6.2	OPENING & FINISH SCHEDULE
A6.3	SIGNAGE DETAILS
A7.0	EXTERIOR ELEVATIONS - DEMOLITION
A7.1	EXTERIOR ELEVATIONS - NEW WORK
A8.0	DETAILS
A8.1	A/V FLOOR PLAN
A8.2	REFERENCE PHOTOS
A9.0	INTERIOR ELEVATIONS
A9.1	INTERIOR ELEVATIONS
A9.2	INTERIOR ELEVATIONS
A9.3	INTERIOR ELEVATIONS
A9.4	INTERIOR ELEVATIONS
A9.5	INTERIOR ELEVATIONS
STRUCTURAL:	
S0.1	GENERAL NOTES
S0.2	TYPICAL DETAILS
S2.1	FOUNDATION PLAN
MECHANICAL:	
M0.1	HVAC LEGEND & NOTES
M0.2	HVAC EQUIPMENT SCHEDULES
M2.0	BUILDING HVAC DEMOLITION PLAN
M2.1	BUILDING HVAC PLAN
M4.0	BUILDING HVAC DEMOLITION ROOF PLAN
M4.1	BUILDING HVAC ROOF PLAN
M5.1	HVAC DETAILS

- APPLICABLE CODES & STANDARDS**
- ALL WORK SHALL CONFORM TO THE FOLLOWING AND ALL OTHER APPLICABLE CODES AND STANDARDS
- 2010 BUILDING STANDARDS ADMINISTRATIVE CODE, PART 1, TITLE 24 C.C.R.
 - 2010 CALIFORNIA BUILDING CODE (CBC), PART 2, VOLUMES #1 & #2, TITLE 24 C.C.R. (2009 INTERNATIONAL BUILDING CODE & 2010 CALIFORNIA AMENDMENTS)
 - 2010 CALIFORNIA ELECTRICAL CODE (CEC), PART 3, TITLE 24 C.C.R. (2008 NATIONAL ELECTRICAL CODE & 2010 CALIFORNIA AMENDMENTS)
 - 2010 CALIFORNIA MECHANICAL CODE (CMC), PART 4, TITLE 24 C.C.R. (2009 UNIFORM MECHANICAL CODE & 2010 CALIFORNIA AMENDMENTS)
 - 2010 CALIFORNIA PLUMBING CODE (CPC), PART 5, TITLE 24 C.C.R. (2009 UNIFORM PLUMBING CODE & 2010 CALIFORNIA AMENDMENTS)
 - 2010 CALIFORNIA ENERGY CODE, PART 6, TITLE 24, C.C.R.
 - 2010 CALIFORNIA FIRE CODE, PART 9, TITLE 24 C.C.R. (2009 INTERNATIONAL FIRE CODE & 2010 CALIFORNIA AMENDMENTS)
 - 2010 CALIFORNIA GREEN BUILDING STANDARDS CODE, PART 11, TITLE 24 C.C.R.
 - 2010 CALIFORNIA REFERENCED STANDARDS, PART 12, TITLE 24 C.C.R.
 - TITLE 19 C.C.R., PUBLIC SAFETY, STATE FIRE MARSHAL REGULATIONS
 - CHAPTER 4, PART 1, TITLE 24, C.C.R., ADMINISTRATIVE REQUIREMENTS
 - 2007 NFPA 10 - PORTABLE FIRE EXTINGUISHERS
 - 2010 NFPA 13 - INSTALLATION OF SPRINKLER SYSTEMS WITH CALIFORNIA AMENDMENTS
 - 2007 NFPA 14 - INSTALLATION OF STANDPIPE, PRIVATE HYDRANT & HOSE SYSTEMS
 - 2010 NFPA 22 - NATIONAL FIRE ALARM CODE WITH CALIFORNIA AMENDMENTS
 - 2003 NFPA 20 - INSTALLATION OF STATIONARY PUMPS FOR FIRE PROTECTION
 - 2010 NFPA 22 - WATER TANKS FOR PRIVATE FIRE PROTECTION
 - 2010 NFPA 24 - INSTALLATION OF PRIVATE FIRE SERVICE MAINS WITH CALIFORNIA AMENDMENTS
 - 2007 NFPA 80 - FIRE DOORS AND OTHER OPENING PROTECTIVES
 - 2005 NFPA 110 - EMERGENCY AND STANDBY POWER SYSTEMS
 - ICC 300-07 - STANDARD ON BLEACHERS, FOLDING AND TELESCOPING SEATING AND GRANDSTANDS
 - 2002 NFPA 17A - UL 300 FOR CLASS I HOOD FIRE SUPPRESSION SYSTEM (WET CHEMICAL SYSTEMS)
 - 2008 NFPA 2001 CLEAN AGENT FIRE EXTINGUISHING SYSTEMS
- NOTE: COMPLIANCE WITH CFC CHAPTER 14, FIRE SAFETY DURING CONSTRUCTION AND DEMOLITION AND CBC CHAPTER 33, SAFETY DURING CONSTRUCTION WILL BE ENFORCED.

- SCOPE OF WORK**
- THE SCOPE OF WORK UNDER THIS DSA APPLICATION INCLUDES THE MODERNIZATION OF THE INTERIOR, AND EXTERIOR ENVELOPE, OF THE SCIENCE BUILDING "S" LOCATED ON THE MT. DIABLO HIGH SCHOOL CAMPUS AND GENERALLY INCLUDES THE FOLLOWING:
- REPLACEMENT OF EXTERIOR WINDOW SYSTEM
 - REPLACEMENT AND RECONFIGURATION OF LABORATORY AND STORAGE CASEWORK SYSTEMS IN LABS, PREPARATION AND STORAGE ROOMS.
 - INSTALLATION OF ADDITIONAL EXIT DOORS FROM LAB SPACES
 - REPLACEMENT OF RESILIENT FLOORING
 - REPLACEMENT OF ACOUSTICAL CEILING TILES
 - RECONFIGURATION OF EXISTING AND INSTALLATION OF NEW POWER AND DATA AND GAS
 - REPLACEMENT TO EXISTING ROOM EXHAUST FANS
 - REPLACEMENT AND RECONFIGURATION OF PLUMBING SYSTEMS INCLUDING SINKS AND GAS
 - MINOR MODIFICATIONS TO EXISTING FIRE ALARM SYSTEM TO ACCOMMODATE NEW WORK
 - ACCESSIBILITY UPGRADES TO AREAS OF WORK WITHIN THE SCIENCE BUILDING AND IMMEDIATE SURROUNDING SITE AREA, INCLUDING RESTROOMS, EXITING, PATH OF TRAVEL AND PARKING

ONE INCH = TWENTY FEET
 ONE-SIXTEENTH INCH = ONE FOOT
 ONE-EIGHTH INCH = ONE FOOT
 ONE-FOURTH INCH = ONE FOOT
 ONE-HALF INCH = ONE FOOT
 THREE-QUARTERS INCH = ONE FOOT
 ONE INCH = ONE FOOT
 ONE AND ONE-HALF INCH = ONE FOOT

**Mt. Diablo High School
 DSA Site Accessibility Code Plan**

1 1"=40'-0"

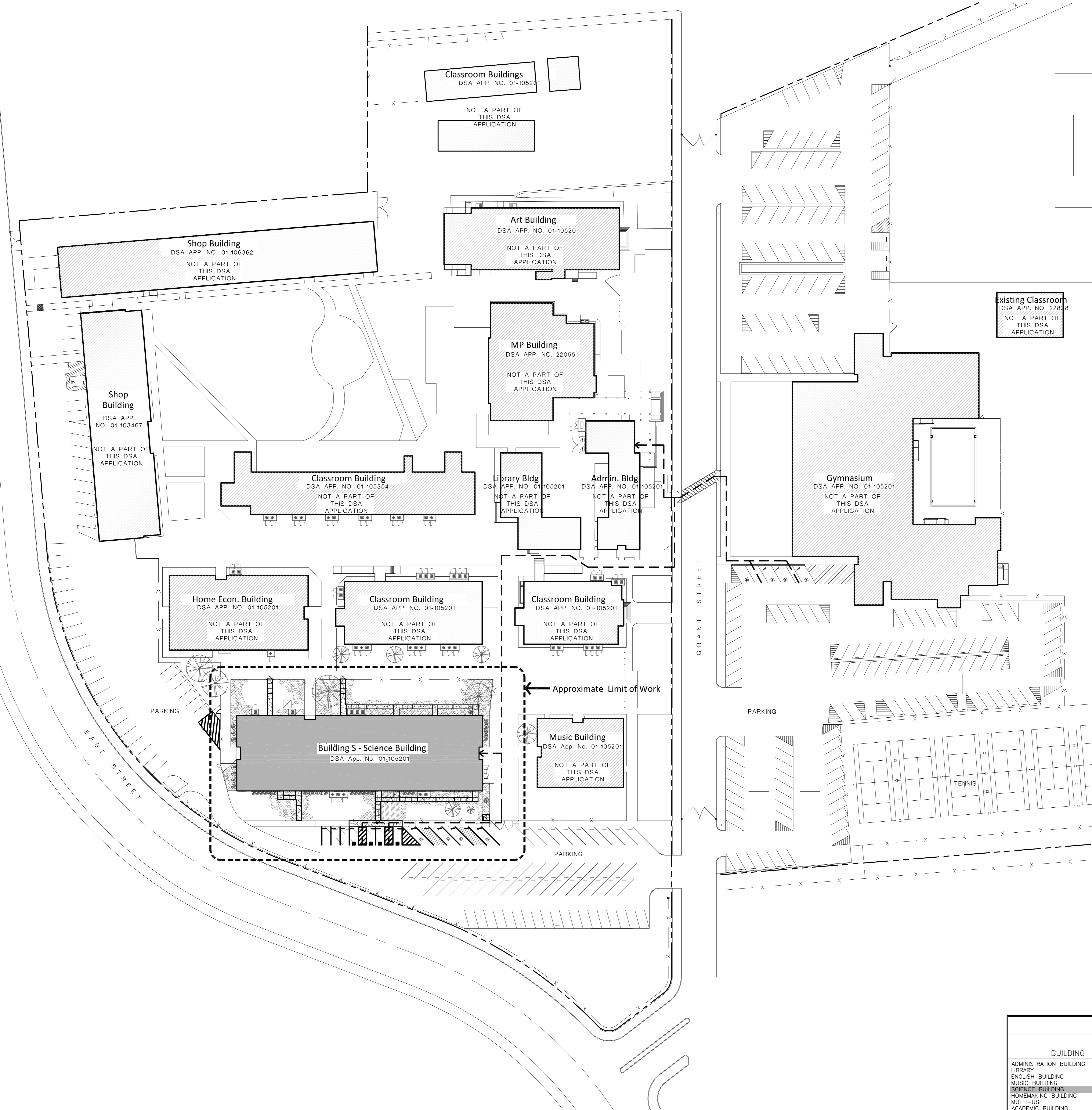

GENERAL NOTES:

ACCESSIBLE PATH OF TRAVEL, TOILET AND PARKING UPGRADES ON THIS SHEET ARE SHOWN FOR REFERENCE ONLY. THIS CAMPUS WAS RECENTLY EXTENSIVELY MODERNIZED UNDER DSA APPLICATION NO. 01-105445. SCOPE INCLUDED, BUT WAS NOT LIMITED TO; ACCESSIBLE PATH OF TRAVEL, ACCESSIBLE STUDENT RESTROOMS, ACCESSIBLE PARKING, DOOR HARDWARE, THRESHOLDS, SIGNAGE, MISCELLANEOUS PUBLIC AREA ACCESSIBILITY UPGRADES, COMPLETE FIRE ALARM UPGRADE AND UPGRADES TO POWER, DATA AND ROOFING.

ACCESSIBLE PATH OF TRAVEL SHOWN IS PER THE REQUIREMENTS OF CBC 1133B AND WAS APPROVED UNDER RECENT CAMPUS-WIDE MODERNIZATION PROJECT, DSA APPLICATION NO. 01-105445.

SYMBOL FOR ACCESSIBLE PATH OF TRAVEL:

ACCESSIBLE ROUTE OF TRAVEL AS INDICATED ON PLAN IS A BARRIER FREE ACCESS ROUTE WITHOUT ANY ABRUPT LEVEL CHANGES EXCEEDING 1/2" IF BEVELED AT 1:2 MAX SLOPE, OR VERTICAL LEVEL CHANGES NOT EXCEEDING 1/4" MAX AND AT LEAST 48" IN WIDTH. SURFACE IS STABLE, FIRM, AND SLIP RESISTANT. CROSS SLOPE DOES NOT EXCEED 2% AND SLOPE IN THE DIRECTION OF TRAVEL IS LESS THAN 5%, UNLESS OTHERWISE INDICATED. ACCESSIBLE ROUTE OF TRAVEL SHALL BE MAINTAINED FREE OF OVERHANGING OBSTRUCTIONS TO 80" MINIMUM AND PROTRUDING OBJECTS GREATER THAN 4" PROJECTION FROM WALL AND ABOVE 27" AND LESS THAN 80". ARCHITECT SHALL VERIFY THAT THERE ARE NO BARRIERS IN THE ROUTE OF TRAVEL.

- EXISTING BUILDINGS
- LOCATION OF SCOPE OF WORK

Existing Classroom
 DSA APP. NO. 22838
 NOT A PART OF THIS DSA APPLICATION

BUILDING	BLDG. AREA	CONSTR. TYPE	OCCUPANCY	ORIGINAL DSA APP. #	LATEST MOD. DSA APP. #
ADMINISTRATION BUILDING	4,835	V NR	B	22055-1962	01-105201-2004
LIBRARY	4,835	V NR	E-1	22055-1962	01-105201-2004
ENGLISH BUILDING	11,865	V NR	E-1	8691-1935	01-105201-2004
MUSIC BUILDING	5,700	V NR	E-1	22055-1962	01-105201-2004
SCIENCE BUILDING	17,690	V NR	E-1	22055-1962	01-105201-2004
HOMEMAKING BUILDING	9,893	V NR	E-1	22055-1962	01-105201-2004
MULTI-USE	10,400	V 1-HR	A-3	22055-1962	01-105201-2004
ACADEMIC BUILDING	17,588	II 1-HR	E-1	6179-1948	01-105201-2004
COMMERCIAL BUILDING	16,854	V 1-HR	E-1	22055-1962	01-105201-2004
WOOD SHOP BUILDING	13,430	V 1-HR	E-1	6945-1949	01-105201-2004
GYMNASIUM	15,495	V-1	A2.1	6571-1949	01-105201-2004
SHOP BUILDING	7,290	V-N	E-1	N/A	01-105201-2004
SHOP BUILDING ADDITION	7,950	V-N	E-1	3382-1940	01-105201-2004
ART BUILDING	17,660	V 1-HR	E-1	1238-1922	01-105201-2004
ART BUILDING ADDITION	1,350	V-N	E-1	10045-1952	01-105201-2004
TOTAL SQ.FT.	166,692				

**Mt. Diablo High School
 Building S - Science Lab Modernization**

2480 Grant Street
 Concord, California 94520

Mt. Diablo Unified School District



FILE NO. XX-XX
 IDENTIFICATION STAMP
 DIV. OF THE STATE ARCHITECT
 OFFICE OF REGULATION SERVICES
 APPLICATION NO. 01-
 AC. FLS. SS
 DATE

DIVISION OF THE STATE ARCHITECT
 revision date: by:

CONSULTANT

nacht&lewis
 600 O Street, Suite 100
 Sacramento, CA 95811
 www.nachtlewis.com
 916.329.4000

ARCHITECT

NO.	DESCRIPTION	DATE	REV'D

DATE February 19, 2012
 JOB NO. Y1211.00
 SHEET TITLE

**Overall
 Site Plan
 & Building Data**

SHEET NO.
A1.0
 SHEET OF TOTAL
 DSA SUBMITTAL SET

ONE AND ONE-HALF INCH = ONE FOOT
ONE INCH = ONE FOOT
THREE-QUARTERS INCH = ONE FOOT
ONE-HALF INCH = ONE FOOT
ONE-QUARTER INCH = ONE FOOT
ONE-EIGHTH INCH = ONE FOOT
ONE-SIXTEENTH INCH = ONE FOOT
ONE INCH = TWENTY FEET

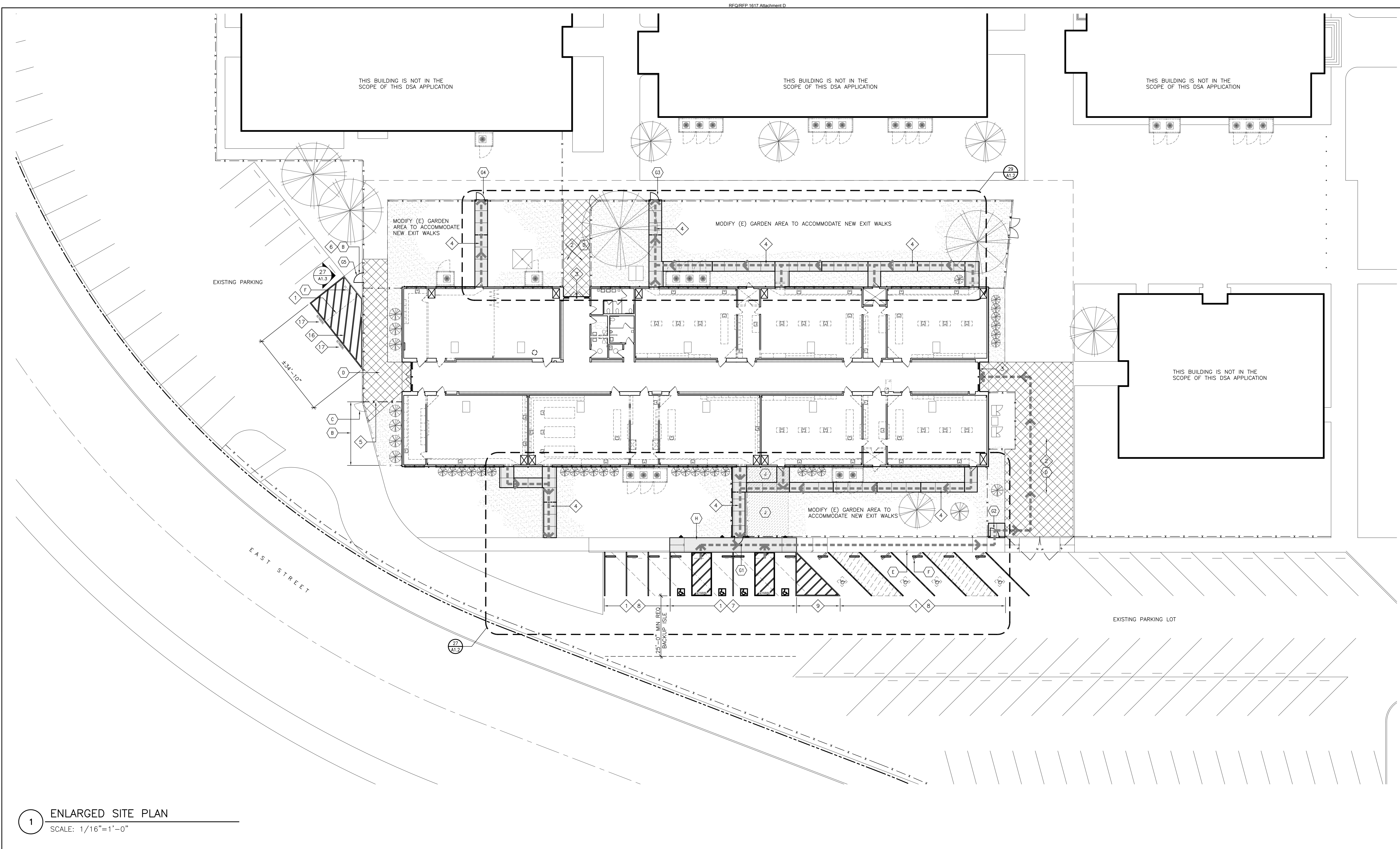

1 ENLARGED SITE PLAN
SCALE: 1/16"=1'-0"

DEMOLITION KEYNOTES:
THESE DEMOLITION NOTES APPLY TO THIS SHEET ONLY

- (A) REMOVE EXISTING CONCRETE PAVING
- (B) REMOVE PORTION OF EXISTING CHAIN LINK FENCE
- (C) REMOVE EXISTING CHAIN LINK GATE
- (D) REMOVE EXISTING AC PAVING
- (E) REMOVE (E) PARKING LOT SIGN AND SIGN POST. REPAIR (E) ADJACENT LANDSCAPING.
- (F) REMOVE AND RELOCATE (E) CONCRETE WHEEL STOP. SEE NEW WORK PLAN.
- (H) REMOVE PORTION OF (E) CONCRETE WALK AS REQUIRED FOR NEW WORK.
- (J) REMOVE (E) LANDSCAPING AS REQUIRED FOR NEW WORK. PATCH & REPAIR (E) LANDSCAPED AREA AT DEMOLISHED AND (N) CONCRETE AS REQ'D. MODIFY (E) IRRIGATION SYSTEM AS REQ'D FOR (N) WORK.

NEW WORK KEYNOTES:
THESE NEW WORK NOTES APPLY TO THIS SHEET ONLY

- 1 SLURRY SEAL OVER (E) STRIPING, LETTERING, AND ISA SYMBOL.
- 2 MODIFY EXISTING ASPHALT AND CONCRETE PAVING TO MEET CURRENT CBC REQUIREMENTS FOR ACCESSIBLE PATH OF TRAVEL
- 3 EXISTING ACCESSIBLE BUILDING ENTRANCE TO REMAIN
- 4 NEW ACCESSIBLE PATH OF TRAVEL OUT OF BUILDING FROM NEW CODE REQUIRED LABORATORY EXIT DOOR - SEE SHEET A1.2
- 5 NEW CHAIN LINK FENCE (6'-0" HIGH)
- 6 NEW CHAIN LINK FENCE GATE (3'-6" W x 6'-0" H) - SEE DETAIL 23/A1.3
- 7 NEW ACCESSIBLE PARKING STALLS (x4) STRIPING, CURBS AND SIGNAGE TO MEET CURRENT CBC REQUIREMENTS - SEE DETAIL 29/A1.3
- 8 NEW PARKING STALLS (x9) STRIPING AND CURBS TO MEET CURRENT CBC REQUIREMENTS - SEE DETAIL 29/A1.3
- 9 (N) CAST IN PLACE, TRUNCATED DOMES, 36" WIDE DETECTABLE WARNING SURFACE.
- 10 LEVEL LANDING AREA AT BASE OF RAMP. SLOPES SHALL NOT EXCEED 1.5% IN ANY DIRECTION.
- 11 (N) CONC. RAMP, 1:15 MAX. SLOPE. GROSS SLOPE SHALL NOT EXCEED 1.5%.
- 12 (N) 48"x48" TOP LEVEL LANDING AREA. SLOPES SHALL NOT EXCEED 1.5% IN ANY DIRECTION.

- 13 (N) CONCRETE EXPANSION JOINT (SEE DETAIL 3A/A1.3)
- 14 (N) ACCESSIBLE CONC. WALK. SLOPE SHALL NOT EXCEED 1.5% IN ANY DIRECTION U.N.O.
- 15 PORTION OF (N) ACCESSIBLE WALK SLOPED TO MEET (E) ADJACENT GRADE. SLOPE SHALL NOT EXCEED 4% MAX. AND 1.5% MAX. GROSS SLOPE.
- 16 (N) 4" WIDE LOADING AREA STRIPING. THE PERIMETER BORDER SHALL BE PAINTED WHITE (EXCEPT AT LOADING AISLE STRIPING) WITH WHITE HATCHED LINES AT 36" MAX. ON CENTER.
- 17 (N) 12" HIGH LETTERING TO READ "NO PARKING". LOADING AISLE HATCHING SHALL NOT INTERSECT WITH LETTERING.
- 18 (N) 3'-0" x 3'-0" PAINTED INTERNATIONAL SYMBOL OF ACCESSIBILITY. (SEE DETAIL 10/A1.3)
- 19 (N) CONC. WHEEL STOP, SEE SPECIFICATION SECTION 02529.
- 20 RELOCATED (E) CONC. WHEEL STOP, REINSTALL PER SPECIFICATION SECTION 02529.
- 21 (N) VAN ACCESSIBLE PARKING STALL SIGN AND SIGN POST. (SEE DETAILS 2/A1.3 & 8/A1.3)
- 22 (N) VAN ACCESSIBLE PARKING STALL WITH ADJACENT LOADING AISLE. SLOPES NOT TO EXCEED 1.5% IN ANY DIRECTION.
- 23 PATCH & REPAIR A/C PAVING AT (N) RAMP AS REQUIRED.
- 24 (N) 4" WIDE PARKING STALL STRIPING (WHITE). LENGTH TO MATCH ADJACENT STALLS.
- 25 INFILL AREA WITH (N) LANDSCAPING TO BEST MATCH (E) ADJACENT.
- 26 (N) 4" WIDE LOADING AISLE STRIPING. THE PERIMETER BORDER SHALL BE PAINTED BLUE WITH WHITE HATCHED LINES AT 36" MAX. ON CENTER.

GENERAL SHEET NOTES:
THESE GENERAL SHEET NOTES APPLY TO THIS SHEET ONLY

- 1. PROVIDE FOR 100 L.F. OF MISCELLANEOUS CONCRETE CRACK/EXPANSION JOINT GRINDING. GRINDING SHALL BE MINIMUM 24" WIDE. LOCATIONS TO BE DETERMINED DURING CONSTRUCTION.
- 2. PROVIDE FOR 100 L.F. OF DAMAGED EXPANSION JOINT MATERIAL REMOVAL AND NEW EXPANSION JOINT MATERIAL/CAULKING INSTALLATION. LOCATIONS TO BE DETERMINED DURING CONSTRUCTION.
- 3. THE TERM "LEVEL" AS DESCRIBED HEREIN SHALL BE CONSIDERED A FLAT SURFACE WITH SLOPES NOT EXCEEDING 1.5% IN ANY DIRECTION.
- 4. PARKING STRIPING AT THE ACCESSIBLE LOADING AISLE SHALL NOT INTERSECT THE 12" HIGH "NO PARKING" LETTERING.

ACCESSIBLE PATH OF TRAVEL

- 1. ACCESSIBLE PATH OF TRAVEL AND BUILDING UPGRADES ON THIS SHEET ARE SHOWN FOR REFERENCE ONLY. ADA ACCESSIBLE PATH OF TRAVEL PER CBC 1133B.
- 2. SYMBOL FOR ACCESSIBLE PATH OF TRAVEL:
- 3. THE SCOPE OF WORK UNDER THIS DSA APPLICATION IS STRICTLY LIMITED TO THE MODERNIZATION IN AND DIRECTLY AROUND THE BUILDING S - SCIENCE LABS. NO OTHER EXISTING PRIMARY STRUCTURES ARE BEING REMOVED OR MODIFIED. NO NEW STRUCTURES OR STRUCTURAL COMPONENTS ARE BEING ADDED.
- 4. ACCESSIBLE ROUTE OF TRAVEL AS INDICATED ON PLAN IS A BARRIER FREE ACCESS ROUTE WITHOUT ANY ABRUPT LEVEL CHANGES EXCEEDING 1/2" IF BEVELED AT 1:2 MAX SLOPE, OR VERTICAL LEVEL CHANGES NOT EXCEEDING 1/4" MAX AND AT LEAST 48" IN WIDTH. SURFACE IS STABLE, FIRM, AND SLIP RESISTANT. GROSS SLOPE DOES NOT EXCEED 2% AND SLOPE IN THE DIRECTION OF TRAVEL IS LESS THAN 5%. UNLESS OTHERWISE INDICATED, ACCESSIBLE ROUTE OF TRAVEL SHALL BE MAINTAINED FREE OF OVERHANGING OBSTRUCTIONS TO 80" MINIMUM AND PROTRUDING OBJECTS GREATER THAN 4" PROJECTION FROM WALL AND ABOVE 27" AND LESS THAN 80". ARCHITECT SHALL VERIFY THAT THERE ARE NO BARRIERS IN THE ROUTE OF TRAVEL.

MDUSD
Mt. Diablo Unified School District
2450 Grant Street
Concord, California 94520



FILE NO. XX-XX
IDENTIFICATION STAMP
DIV. OF THE STATE ARCHITECT
OFFICE OF REGULATION SERVICES
APPLICATION NO. 01-
AC. FLS. SS
DATE

DIVISION OF THE STATE ARCHITECT
revision date: by:

CONSULTANT

nacht&lewis
600 Q Street, Suite 100
Sacramento, CA 95811
www.nachtlewis.com
916.329.4000

ARCHITECT

REVISIONS		
NO.	DESCRIPTION	DATE / REV

DATE February 19, 2012

JOB NO. Y1211.00

SHEET TITLE

Enlarged Site Plan

SHEET NO.

A1.1

SHEET ___ OF TOTAL
DSA SUBMITTAL SET

ONE AND ONE-HALF INCH = ONE FOOT
ONE INCH = ONE FOOT
THREE-QUARTERS INCH = ONE FOOT
ONE-HALF INCH = ONE FOOT
ONE-QUARTER INCH = ONE FOOT
ONE-EIGHTH INCH = ONE FOOT
ONE-SIXTEENTH INCH = ONE FOOT
ONE INCH = TWENTY FEET

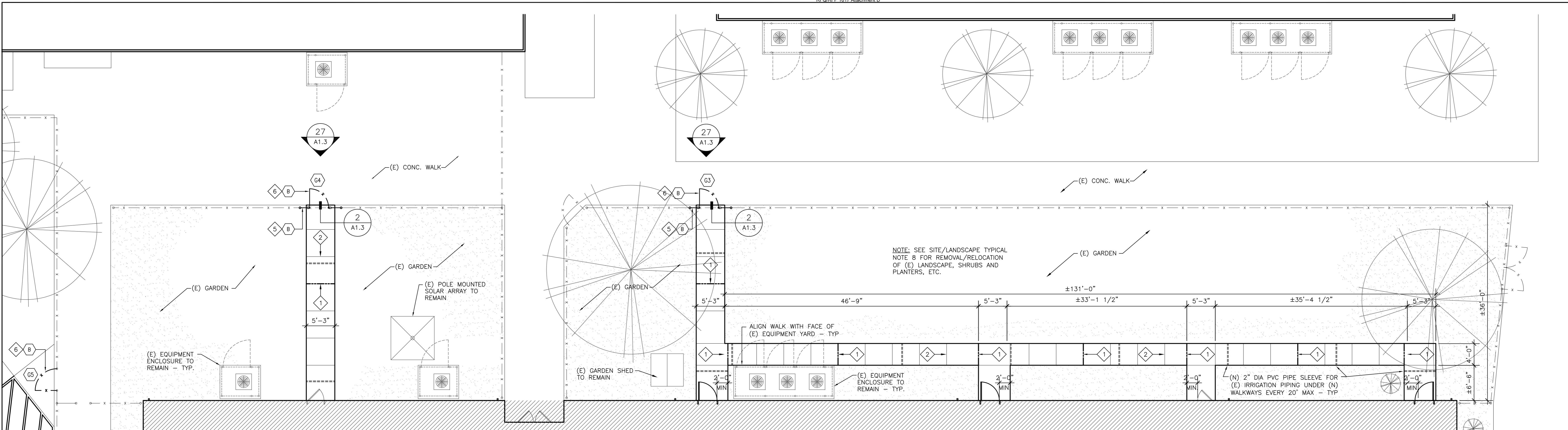

29 ENLARGED PAVING PLAN
SCALE: 1/8" = 1'-0"

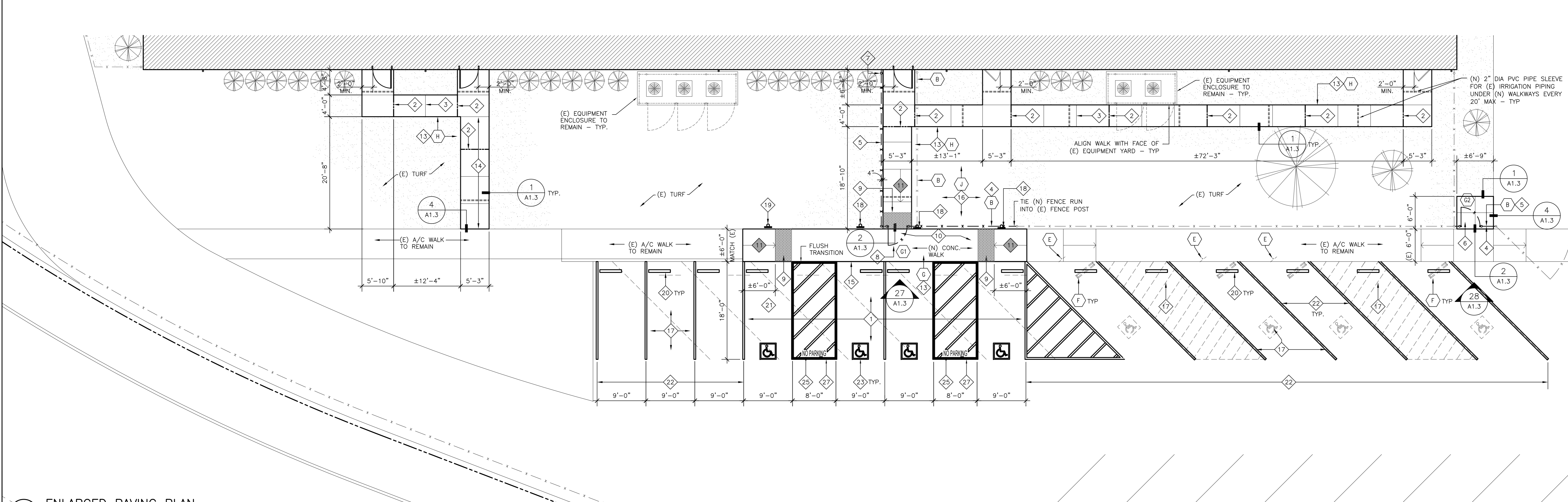

27 ENLARGED PAVING PLAN
SCALE: 1/8" = 1'-0"

DEMOLITION KEYNOTES:

- THESE DEMOLITION KEYNOTES APPLY TO THIS SHEET ONLY.
- (A) REMOVE EXISTING CONCRETE PAVING
- (B) DEMO PORTION OF (E) FENCE AND ASSOCIATED FENCE POSTS AND FOOTINGS.
- (C) REMOVE EXISTING CHAIN LINK GATE
- (D) REMOVE EXISTING AC PAVING
- (E) REMOVE (E) PARKING LOT SIGN AND SIGN POST. REPAIR (E) ADJACENT LANDSCAPING.
- (F) REMOVE AND RELOCATE (E) CONCRETE WHEEL STOP.
- (G) REMOVE PORTION OF (E) CONCRETE WALK AS REQUIRED FOR NEW WORK.
- (H) REMOVE (E) LANDSCAPING AS REQUIRED FOR NEW WORK. PATCH & REPAIR (E) LANDSCAPED AREA AT DEMOLISHED AND (N) CONCRETE AS REQ'D. MODIFY (E) IRRIGATION SYSTEM AS REQ'D FOR (N) WORK.
- (J) DEMO (E) NON-ACCESSIBLE CONCRETE WALK (APPROX. 530 S.F.). PROVIDE (N) TURF AROUND (N) CONCRETE WALK. MODIFY EXISTING IRRIGATION TO PROVIDE EXPANDED COVERAGE.

NEW WORK KEYNOTES:

- THESE NEW WORK KEYNOTES APPLY TO THIS SHEET ONLY
- (1) MODIFY EXISTING ASPHALT AND CONCRETE PAVING TO MEET CURRENT CBC REQUIREMENTS FOR ACCESSIBLE PATH OF TRAVEL
- (2) (N) CONCRETE EXPANSION JOINT, SEE DETAIL 3A/A1.3.
- (3) (N) CONCRETE CONTROL JOINT, SEE DETAIL 3/A1.3.
- (4) (N) ISA SIGN AT SITE ENTRY GATE, SEE DETAIL 21/A1.3.
- (5) (N) CHAIN LINK FENCE (6'-0" HIGH)
- (6) (N) CHAIN LINK FENCE GATE (3'-6" W x 6'-0" H) - SEE DETAIL 23/A1.3
- (7) (N) FENCE END POST AT BUILDING, SEE DETAIL 5/A1.3.
- (8) (N) ACCESSIBLE EXITING GATE, SEE DETAIL 27/A1.3.
- (9) (N) CAST IN PLACE, TRUNCATED DOMES, 36" WIDE DETECTABLE WARNING SURFACE.
- (10) LEVEL LANDING AREA AT BASE OF RAMP. SLOPES SHALL NOT EXCEED 1.5% IN ANY DIRECTION.
- (11) (N) CONC. RAMP, 1:15 MAX. SLOPE. CROSS SLOPE SHALL NOT EXCEED 1.5%.
- (12) (N) 48"x48" TOP LEVEL LANDING AREA. SLOPES SHALL NOT EXCEED 1.5% IN ANY DIRECTION.
- (13) (N) ACCESSIBLE CONC. WALK. SLOPE SHALL NOT EXCEED 1.5% IN ANY DIRECTION U.N.O.

- (14) PORTION OF (N) ACCESSIBLE WALK SLOPED TO MEET (E) ADJACENT GRADE. SLOPE SHALL NOT EXCEED 4% MAX. AND 1.5% MAX. CROSS SLOPE.
- (15) PATCH & REPAIR A/C PAVING AT (N) RAMP/WALKWAY AS REQ.
- (16) INFILL AREA WITH (N) LANDSCAPING TO BEST MATCH (E) ADJACENT.
- (17) SLURRY SEAL OVER (E) STRIPING, LETTERING, AND ISA SYMBOL.
- (18) (N) ACCESSIBLE PARKING STALL SIGN AND POST. (SEE DETAILS 11/A1.3 & 12/A1.3)
- (19) (N) VAN ACCESSIBLE PARKING STALL SIGN AND SIGN POST. (SEE DETAILS 11/A1.3 & 13/A1.3)
- (20) RELOCATED (E) CONC. WHEEL STOP, REINSTALL PER SPECIFICATION SECTION 32 17 13.19.
- (21) (N) VAN ACCESSIBLE PARKING STALL WITH ADJACENT LOADING AISLE. SLOPES NOT TO EXCEED 1.5% IN ANY DIRECTION.
- (22) (N) 4" WIDE PARKING STALL STRIPING (WHITE). LENGTH TO MATCH (E) ADJACENT STALLS.
- (23) (N) 3'-0" x 3'-0" PAINTED INTERNATIONAL SYMBOL OF ACCESSIBILITY. (SEE DETAIL 6/A1.3)
- (24) (N) 4" WIDE ACCESS AISLE STRIPING. THE PERIMETER BORDER SHALL BE PAINTED WHITE (EXCEPT AT LOADING AISLE STRIPING) WITH WHITE HATCHED LINES AT 36" MAX. ON CENTER.
- (25) (N) 12" HIGH LETTERING TO READ "NO PARKING". ACCESS AISLE HATCHING SHALL NOT INTERSECT WITH LETTERING.
- (26) (N) 4" WIDE LOADING AISLE STRIPING. THE PERIMETER BORDER SHALL BE PAINTED BLUE WITH WHITE HATCHED LINES AT 36" MAX. ON CENTER.

SITE/LANDSCAPE TYPICAL NOTES:

- NOTE: THESE TYPICAL NOTES APPLY TO ALL NEW CONCRETE WALKS, U.O.N.
- 1. NOT ALL REQUIRED WORK MAY BE SHOWN ON ENLARGED PLANS. SEE MECHANICAL AND ELECTRICAL DRAWINGS FOR ADDITIONAL WORK.
- 2. HOT-DIP GALVANIZE ALL STEEL ANGLE AND PLATE COMPONENTS AFTER FABRICATION INCLUDING FENCE GATES AND HARDWARE, RODS AND NUTS, BOLTS, ETC. PAINTING OF THESE COMPONENTS IS NOT REQUIRED.
- 3. PAINT ALL NEW EXPOSED ELECTRICAL CONDUITS THAT OCCUR ON EXTERIOR OF BUILDING, SEE MECHANICAL AND ELECTRICAL DRAWINGS FOR ADDITIONAL PAINT AND FINISH SCOPE.
- 5. WALKS IN LANDSCAPED/GARDEN AREAS: REMOVE EXISTING LANDSCAPING AND PLANTERS ONLY TO THE EXTENT REQUIRED TO INSTALL THE NEW WORK. COORDINATE WITH THE CONSTRUCTION MANAGER PRIOR TO REMOVAL OF SHRUBS/PLANTERS TO DETERMINE IF THE DISTRICT WISHES TO HAVE PLANTS/MATERIAL SALVAGED BACK TO THE DISTRICT FOR RELOCATION BY DISTRICT GROUNDS CREW. NOTIFY THE CONSTRUCTION MANAGER IN THE EVENT THAT TREES PROHIBIT INSTALLATION OF THE WALKS IN THE LOCATION DENOTED ON THE DRAWINGS FOR FURTHER DIRECTION ON HOW TO PROCEED. REPAIR ANY PLANTERS, LANDSCAPE IRRIGATION LINES OR SPRINKLERS THAT ARE DAMAGED BY THE INSTALLATION OF THE NEW WORK. RELOCATE ANY PLANTERS, LANDSCAPE IRRIGATION LINES OR SPRINKLERS THAT OCCUR WITHIN THE EXTENTS OF THE NEW WALKS. UPON COMPLETION OF THE WORK, RESTORE THE LANDSCAPING & PLANTERS IN THE IMMEDIATE VICINITY OF THE YARD TO MATCH THE ADJACENT PLANTING/GARDENS (i.e. RESTORE LAWN AREAS, GROUND COVERS, ETC.). LAWN AREAS SHALL BE RESTORED WITH SOG.
- 6. FLATWORK IN PAVED AREAS: SAW-CUT AND REMOVE EXISTING CONCRETE OR A.C. PAVING ONLY TO THE EXTENT REQUIRED TO INSTALL THE NEW WORK. UPON COMPLETION OF THE WORK PATCH AND REPAIR ANY EXISTING PAVING THAT WAS DAMAGED BY THE INSTALLATION OF THE NEW WORK. PATCH AND REPAIR THE EXISTING PAVING ALONG THE EDGES OF THE NEW FLATWORK TO PROVIDE FOR A NEAT TIGHT JOINT.
- 7. ALL NEW SIDEWALKS SHALL BE INSTALLED 1/4" BELOW FINISH FLOOR AT EXTERIOR DOOR LOCATIONS AND GENERALLY FOLLOW (E) GRADE BUT SHALL NOT EXCEED 2% SLOPE IN ANY DIRECTION.
- 8. SEE SPECIFICATION SECTION 32 80 01 AND 32 91 20 FOR ADDITIONAL IRRIGATION AND LANDSCAPE REPAIR REQUIREMENTS.

LEGEND:

- NEW CONCRETE PAVING - SEE SHEET A1.3
- EXISTING PLANTER AREA/TURF
- EXPANSION JOINT - SEE DETAIL 3A/A1.3
- CONTROL JOINT - SEE DETAIL 3/A1.3

Mt. Diablo High School
Building S - Science Lab Modernization
2450 Grant Street
Concord, California 94520
Mt. Diablo Unified School District
MDUSD
APPLICATION NO. 01-
AC. FLS. SS
DATE

FILE NO. XX-XX
DIVISION OF THE STATE ARCHITECT
OFFICE OF REGULATION SERVICES
APPLICATION NO. 01-
AC. FLS. SS
DATE

DIVISION OF THE STATE ARCHITECT
revision date: by:

CONSULTANT
nacht&lewis
600 Q Street, Suite 100
Sacramento, CA 95811
www.nachtlewis.com
916.329.4000

ARCHITECT
REVISIONS

NO.	DESCRIPTION	DATE	REV'D

DATE February 19, 2012
JOB NO. Y1211.00
SHEET TITLE
Enlarged Paving Plans
SHEET NO.
A1.2
SHEET ___ OF ___ TOTAL
DSA SUBMITTAL SET

ONE AND ONE-HALF INCH = ONE FOOT
 ONE INCH = ONE FOOT
 THREE-QUARTERS INCH = ONE FOOT
 ONE-HALF INCH = ONE FOOT
 ONE-QUARTER INCH = ONE FOOT
 ONE-EIGHTH INCH = ONE FOOT
 ONE-SIXTEENTH INCH = ONE FOOT
 ONE INCH = TWENTY FEET

REQ/REP.1617 Attachment D

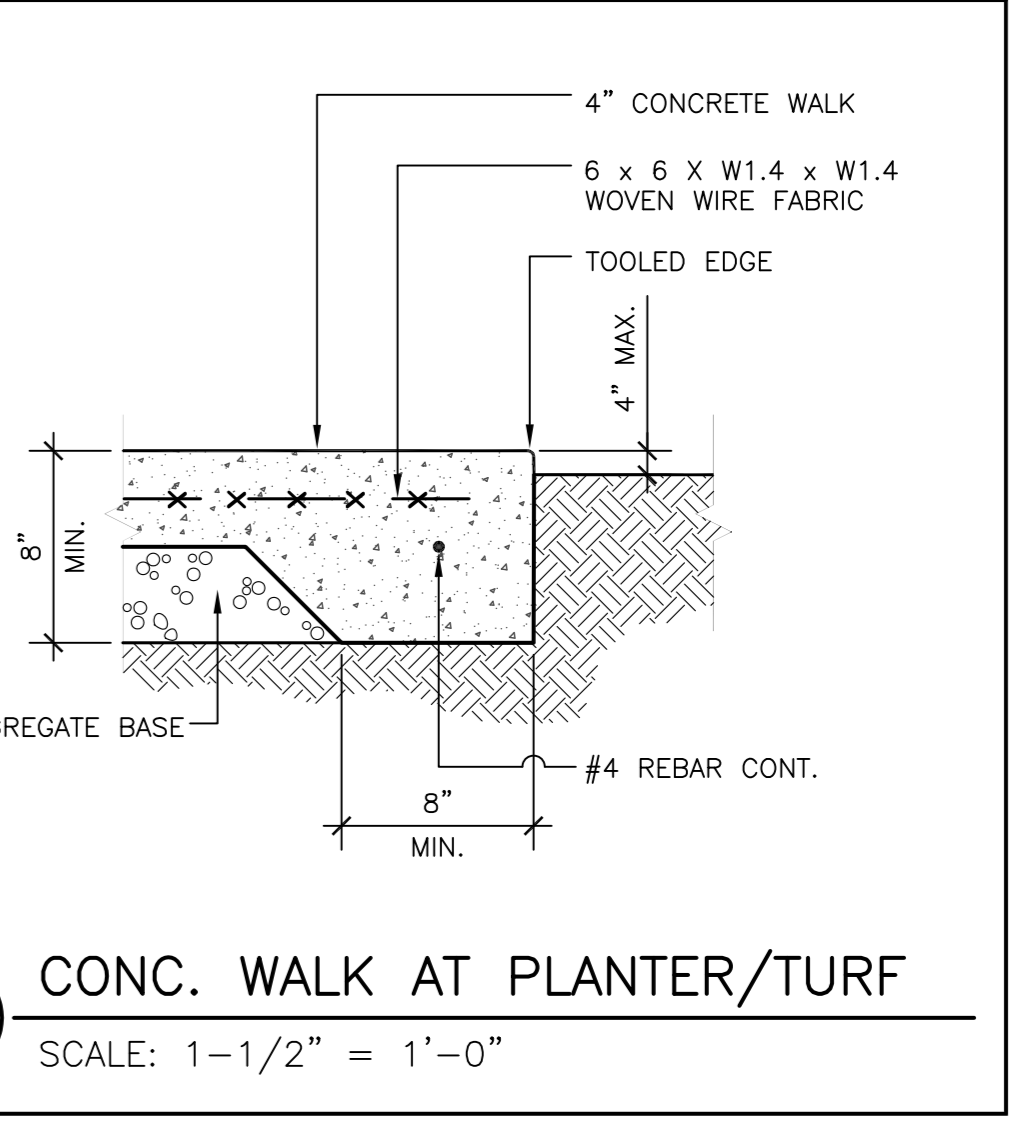
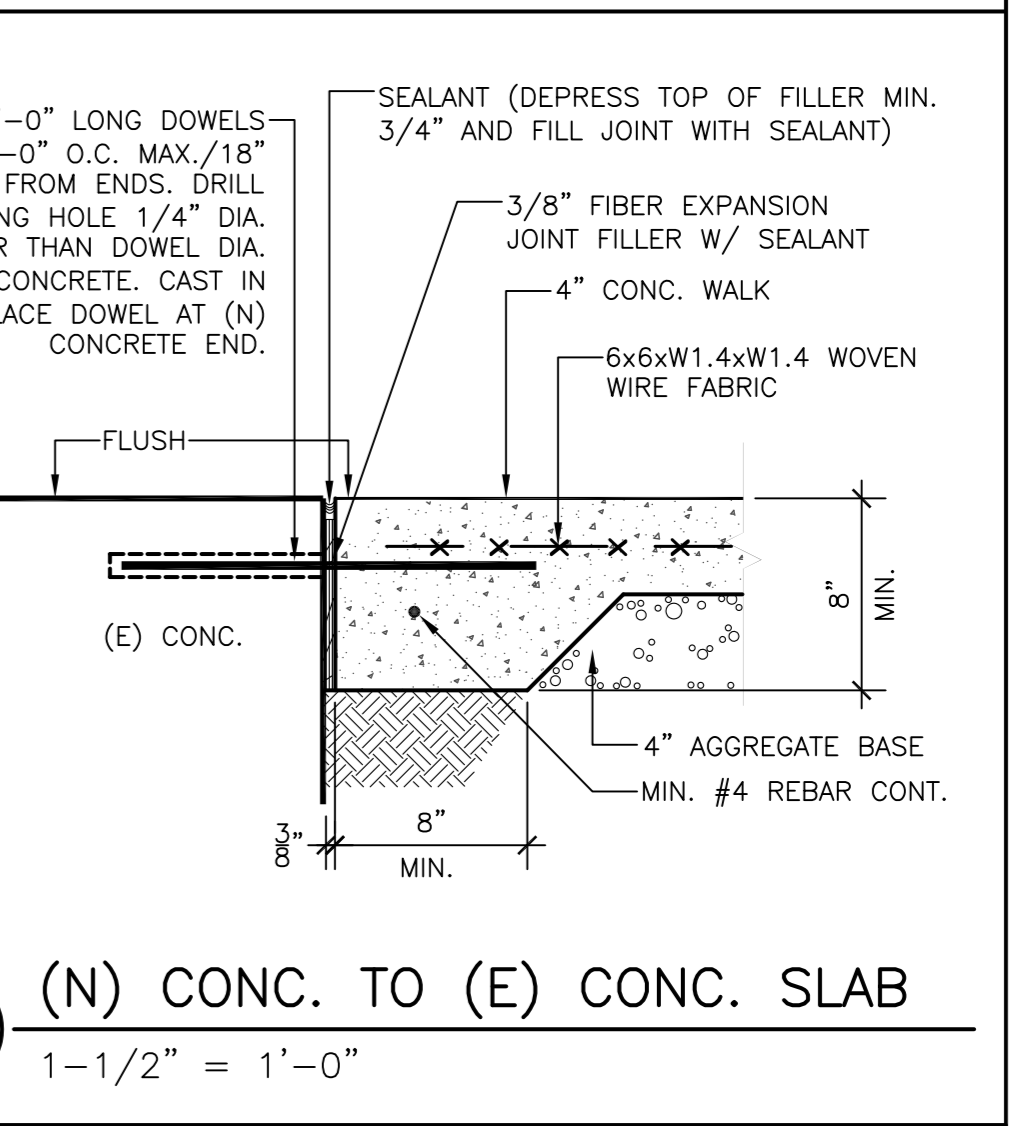
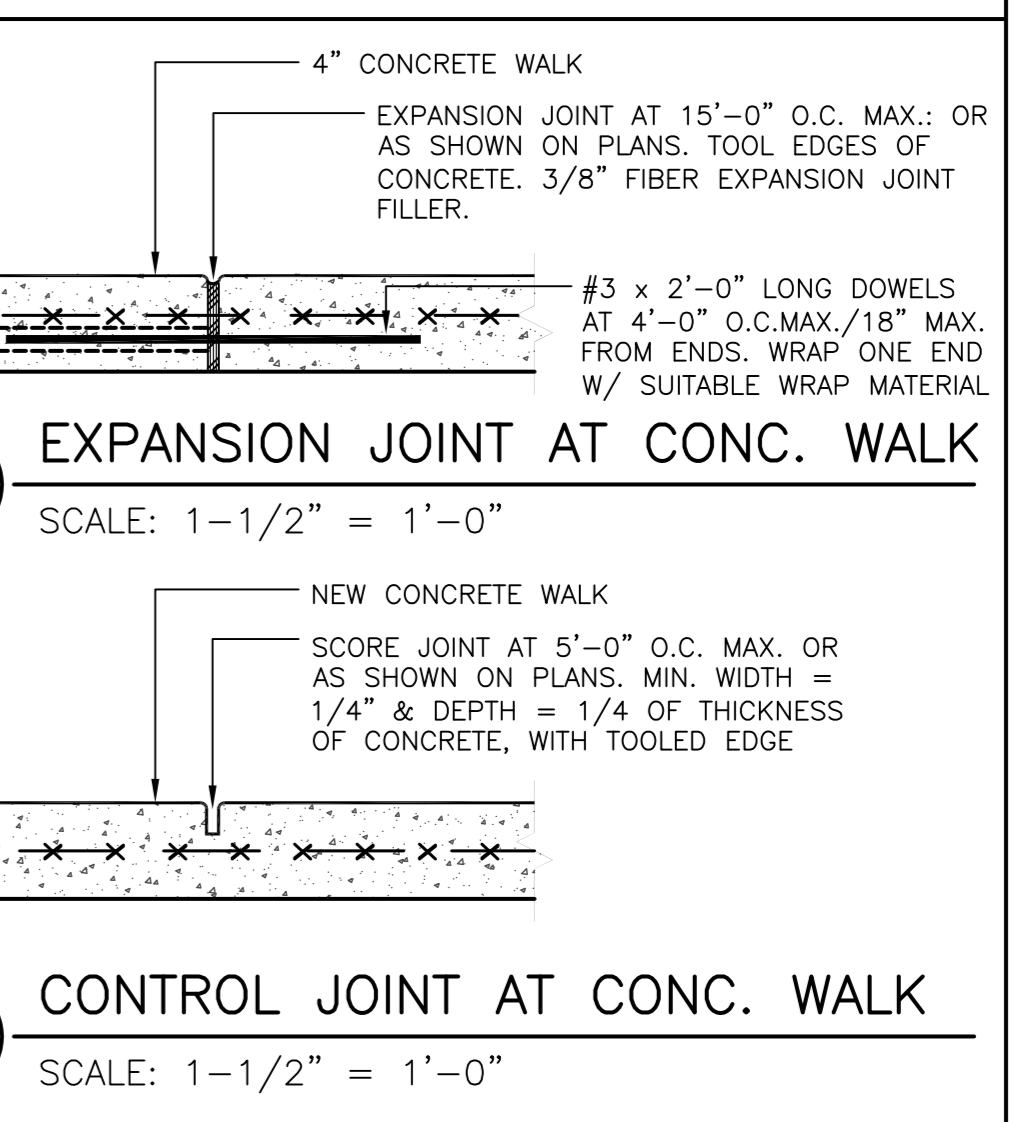
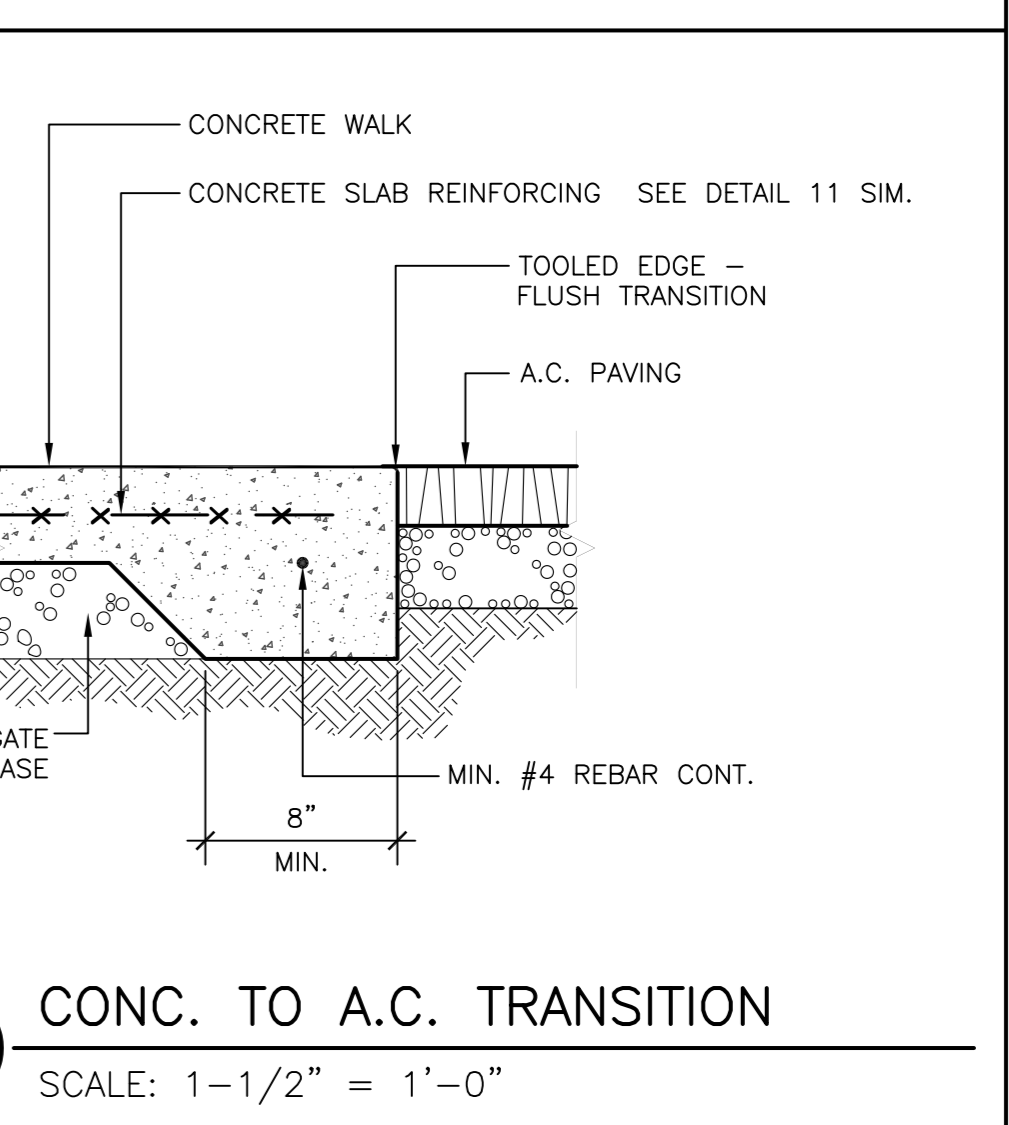
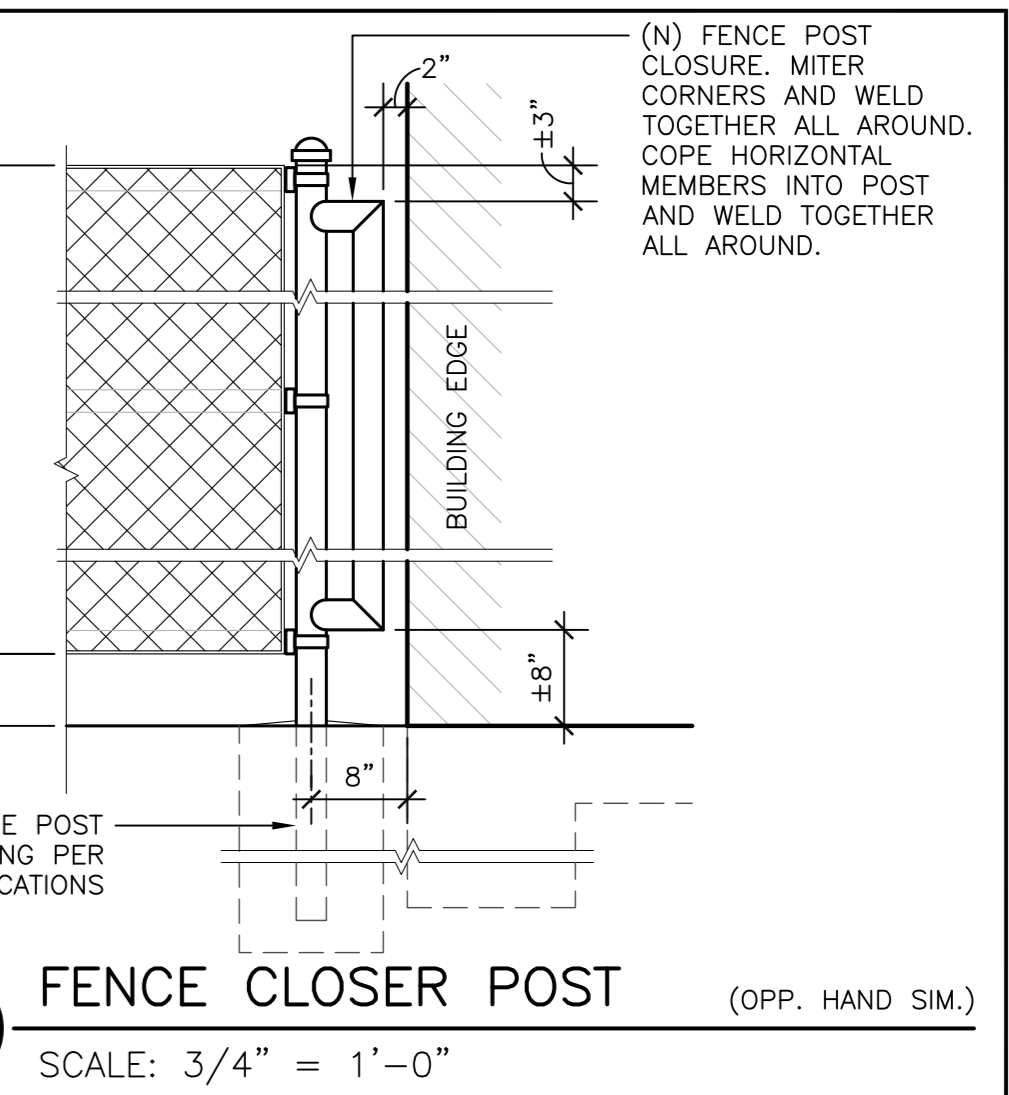
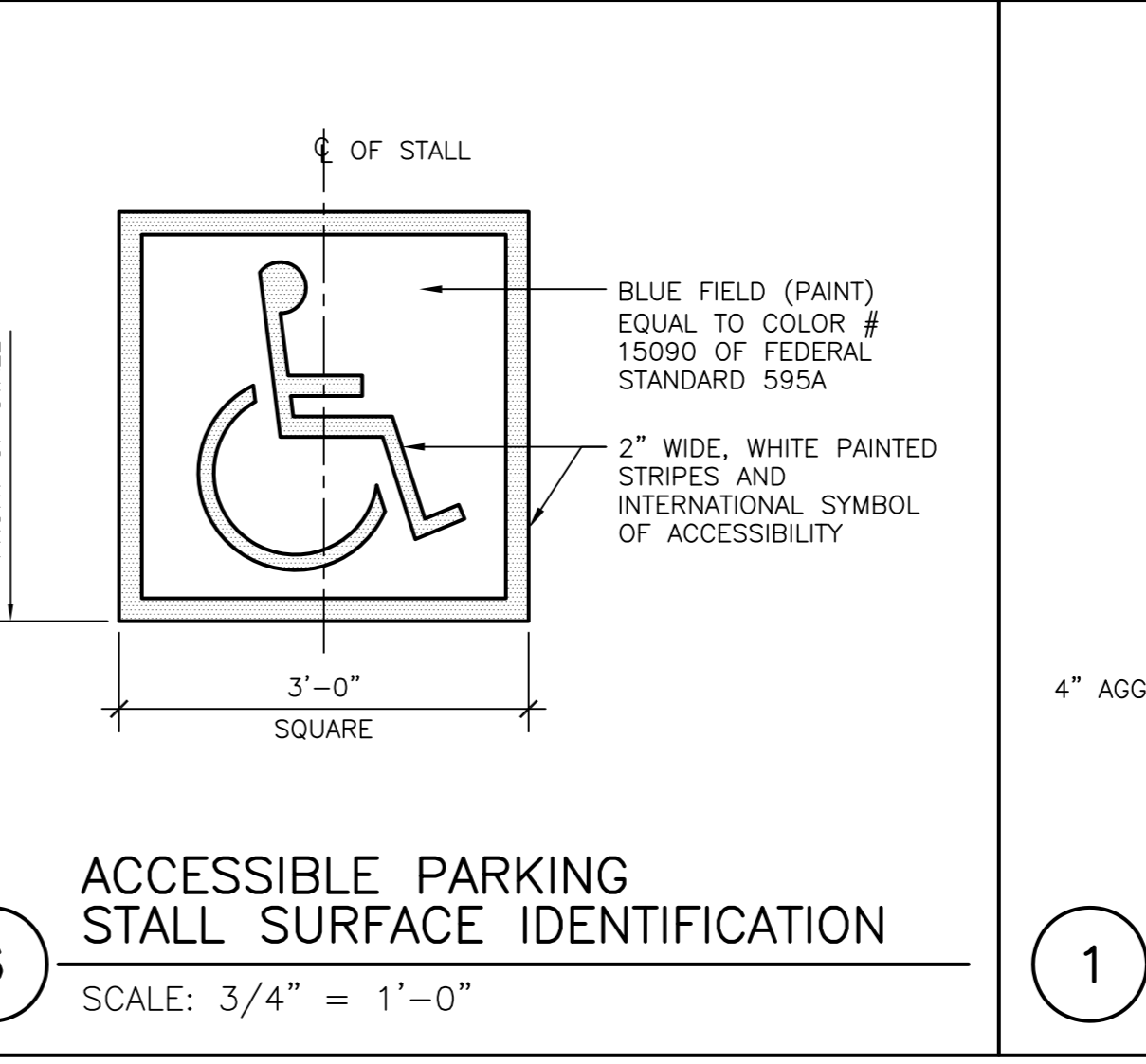
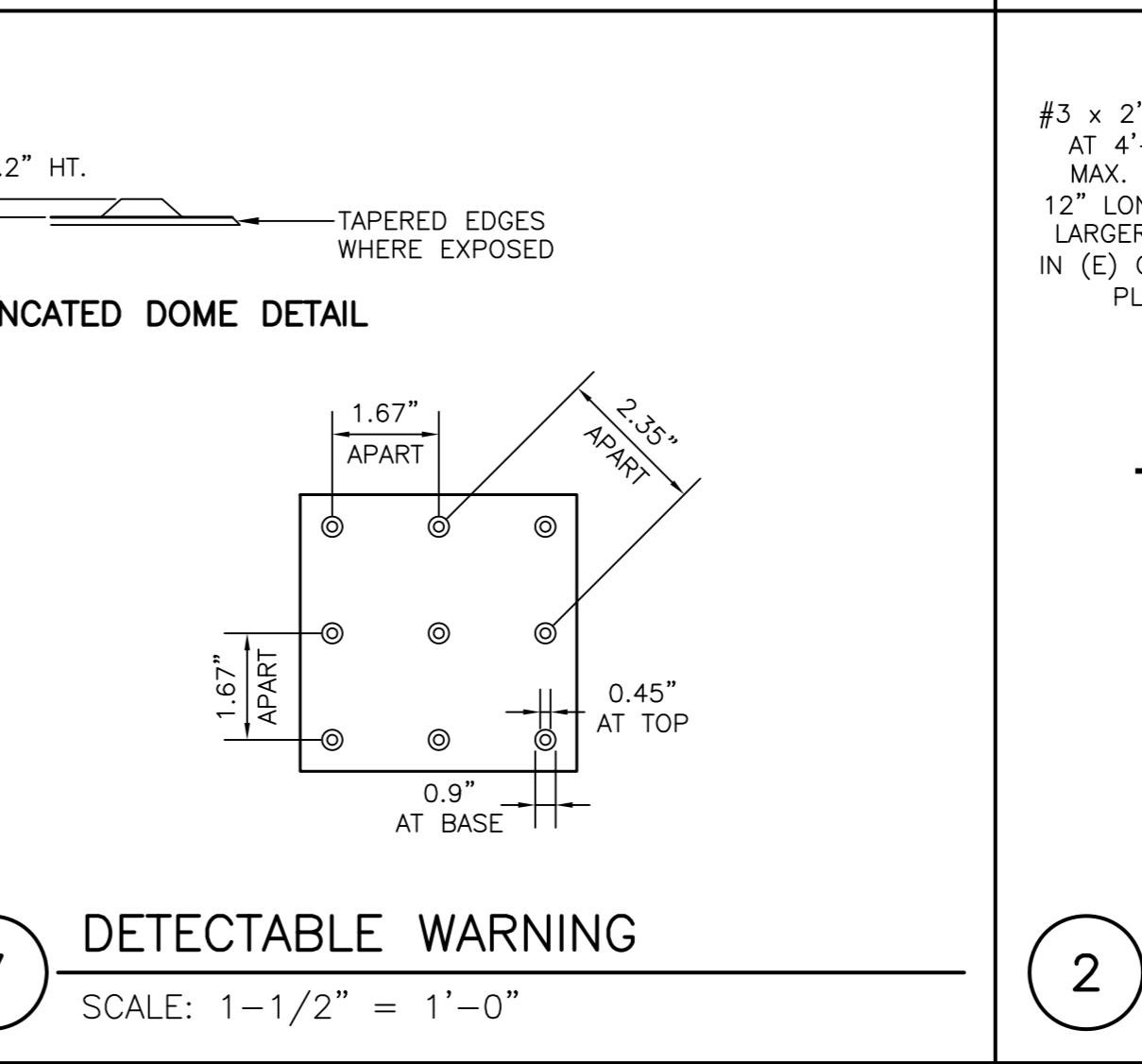
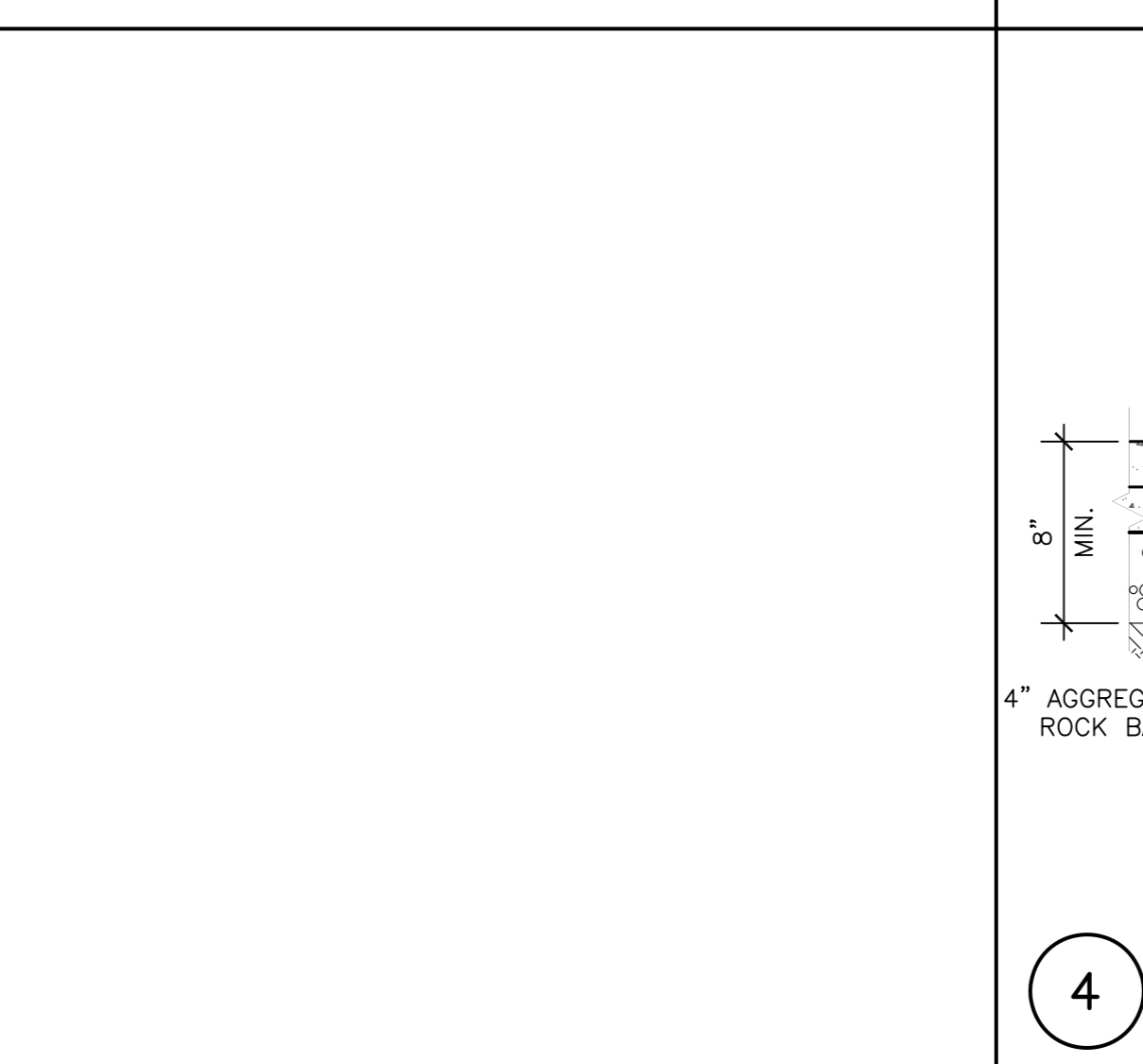
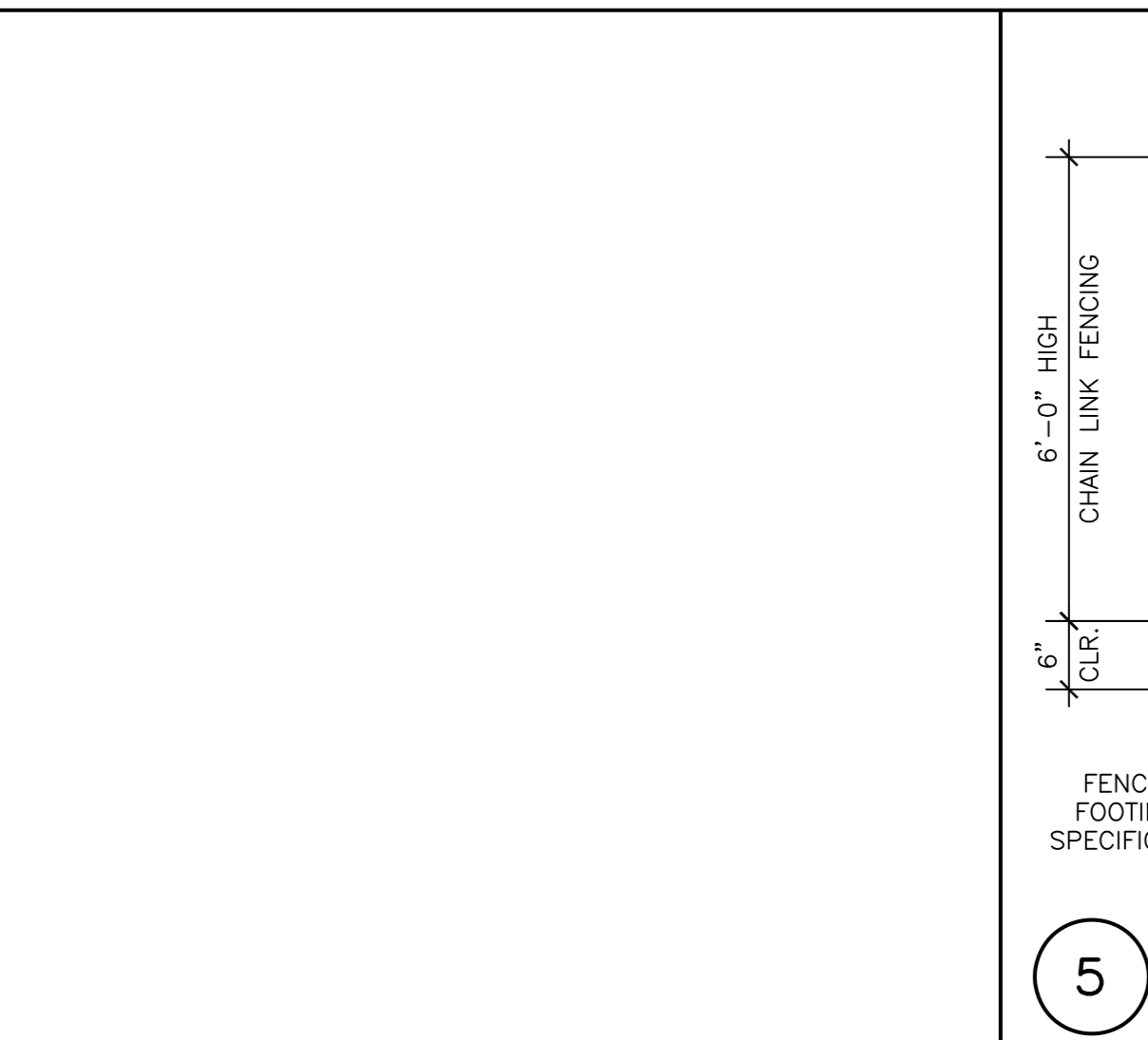
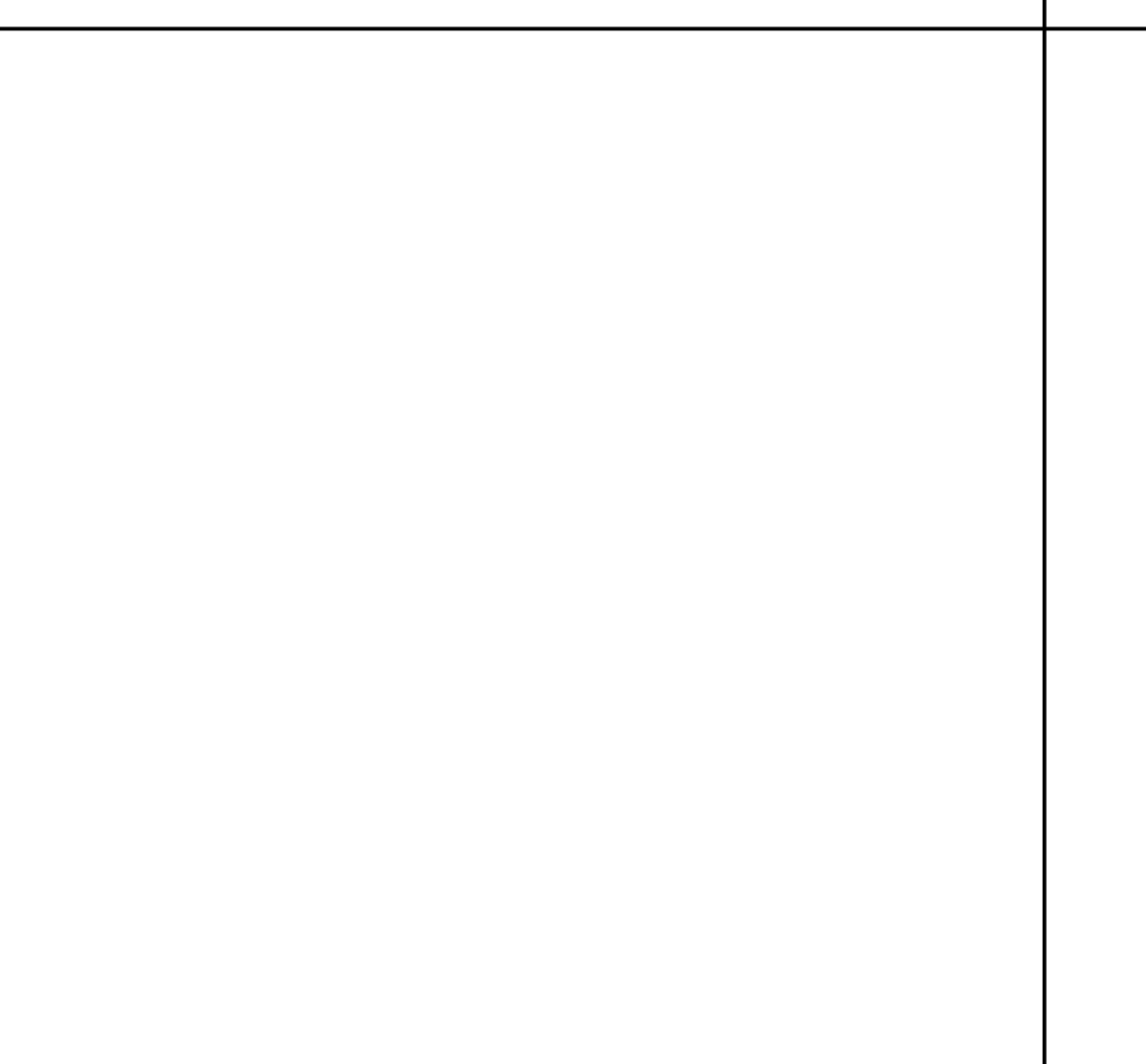
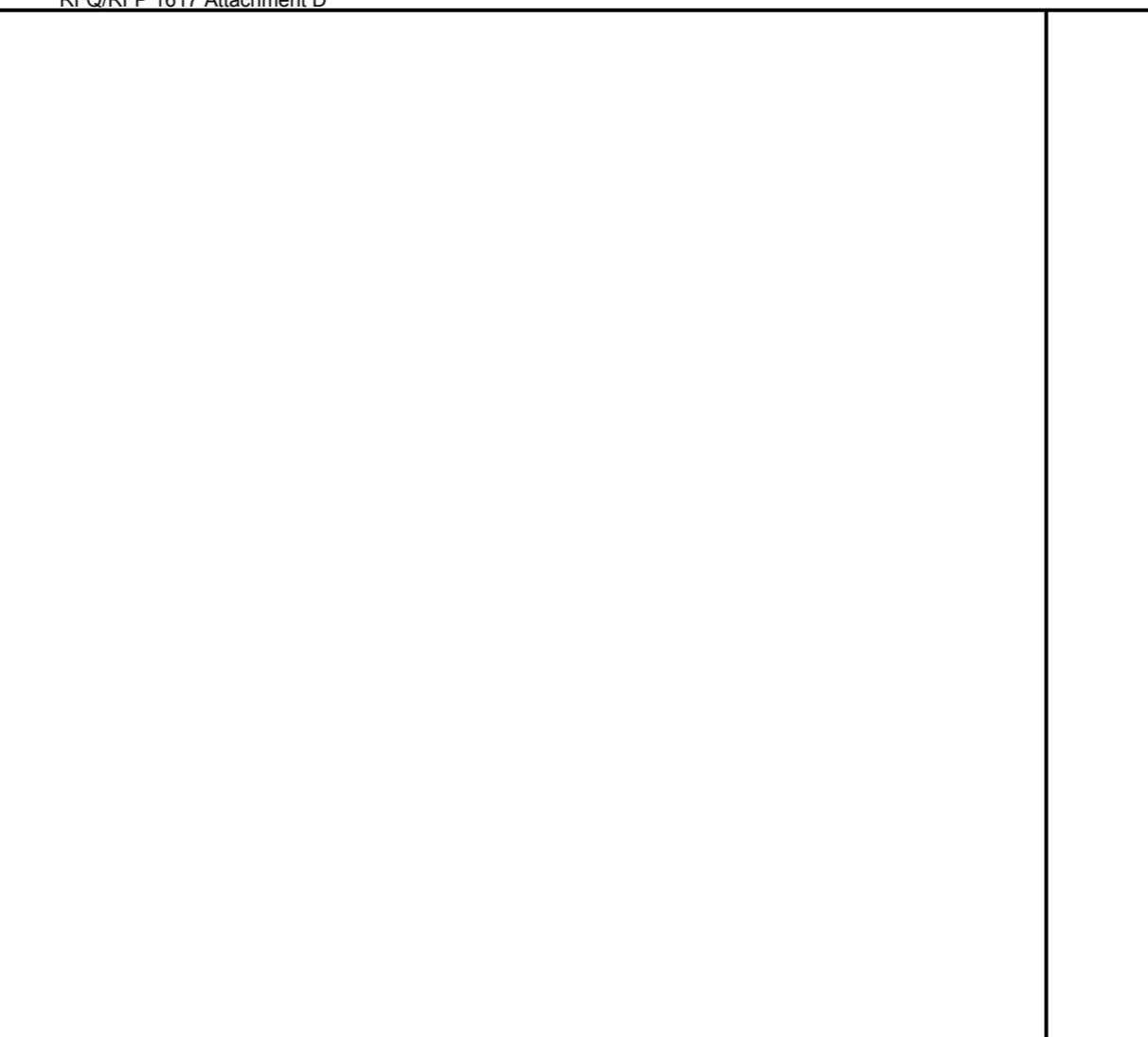
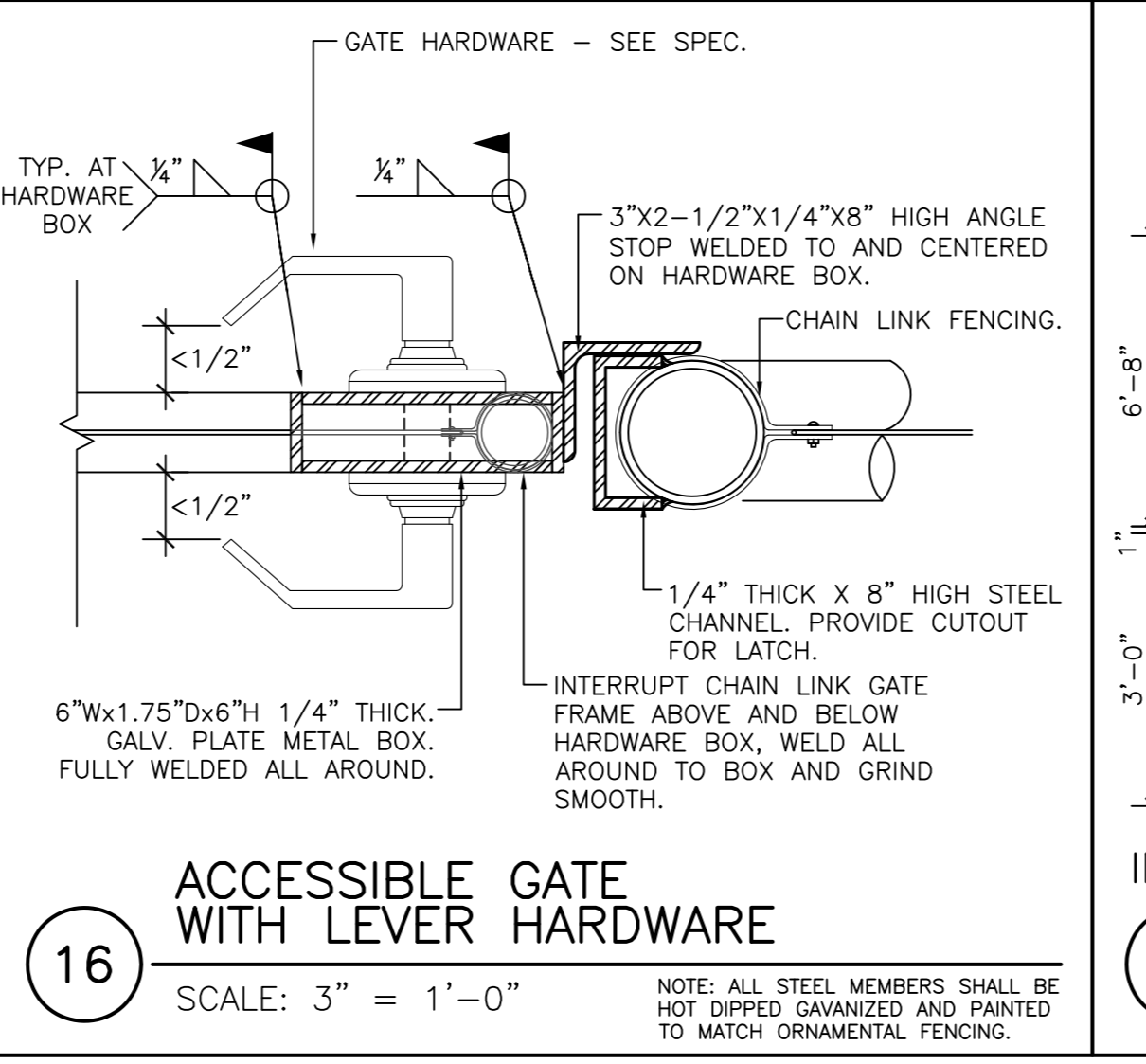
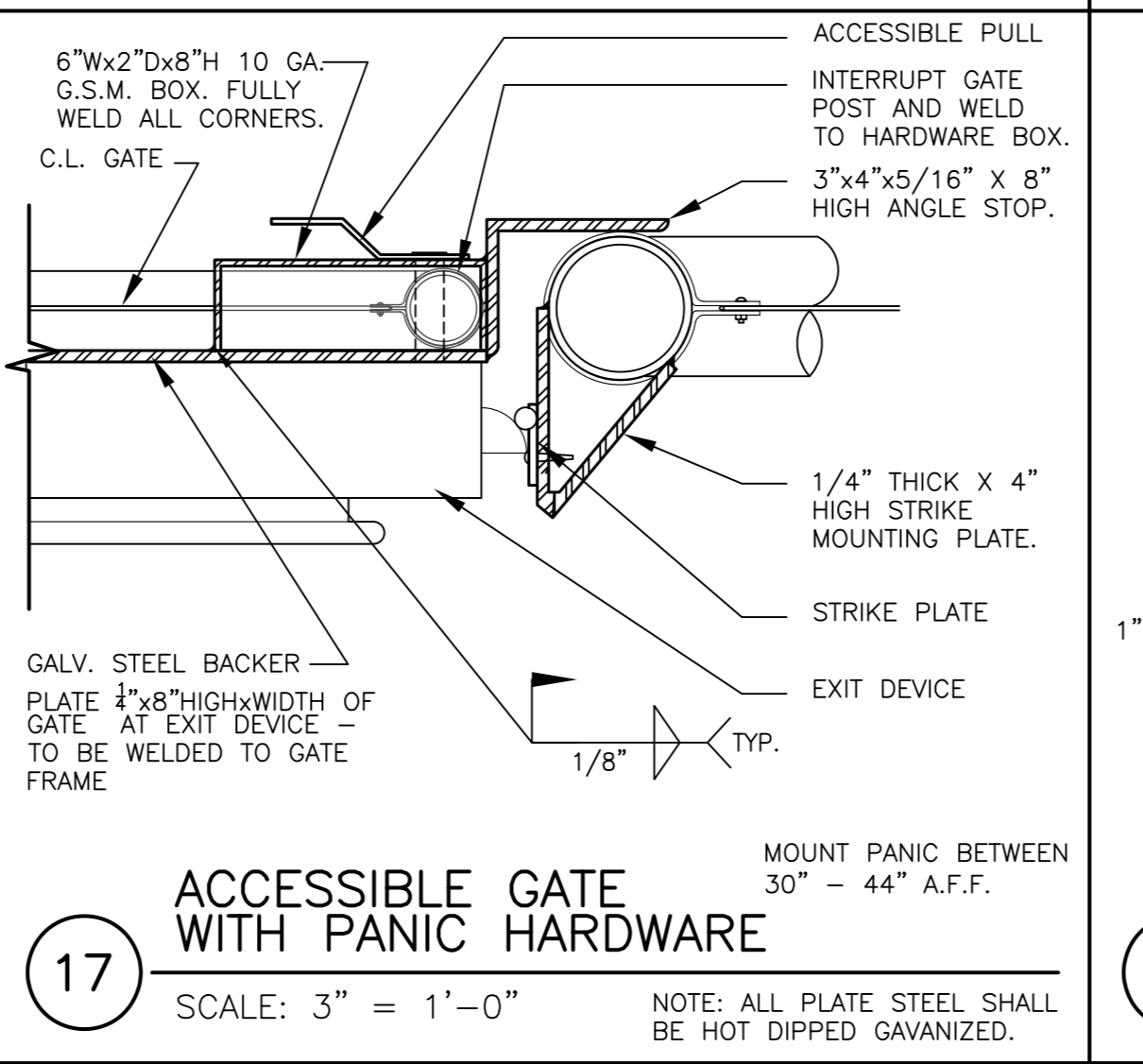
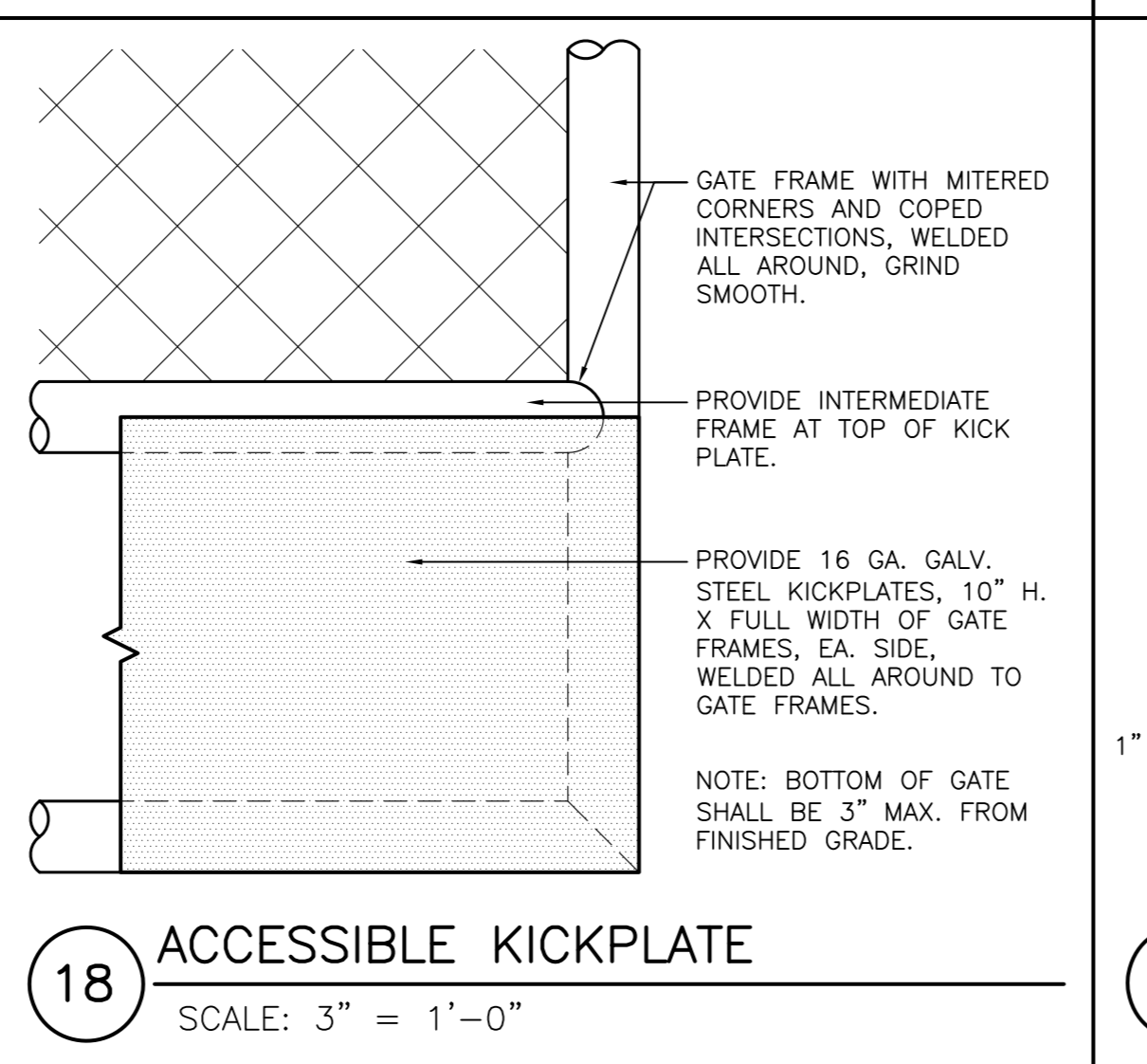
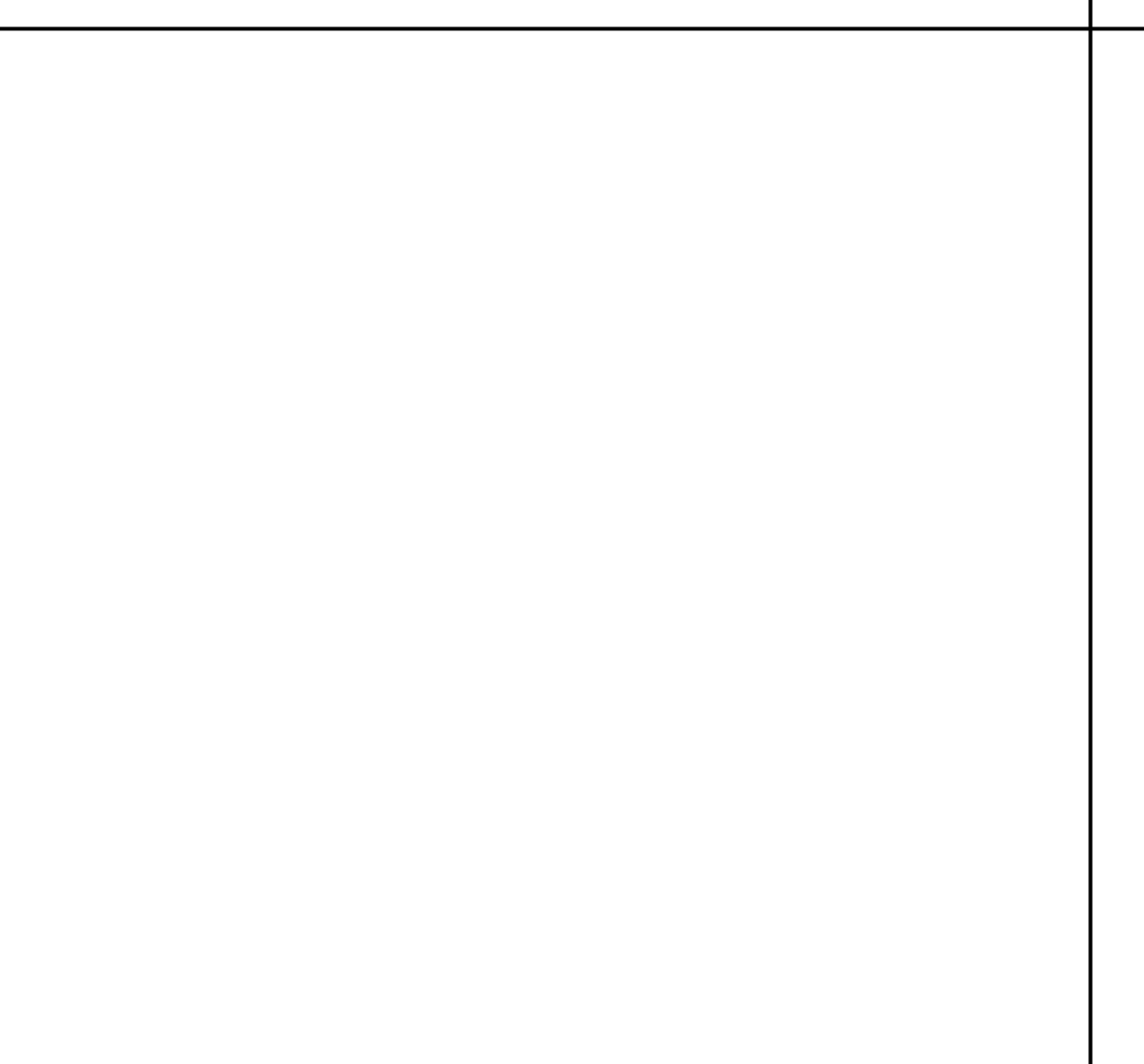
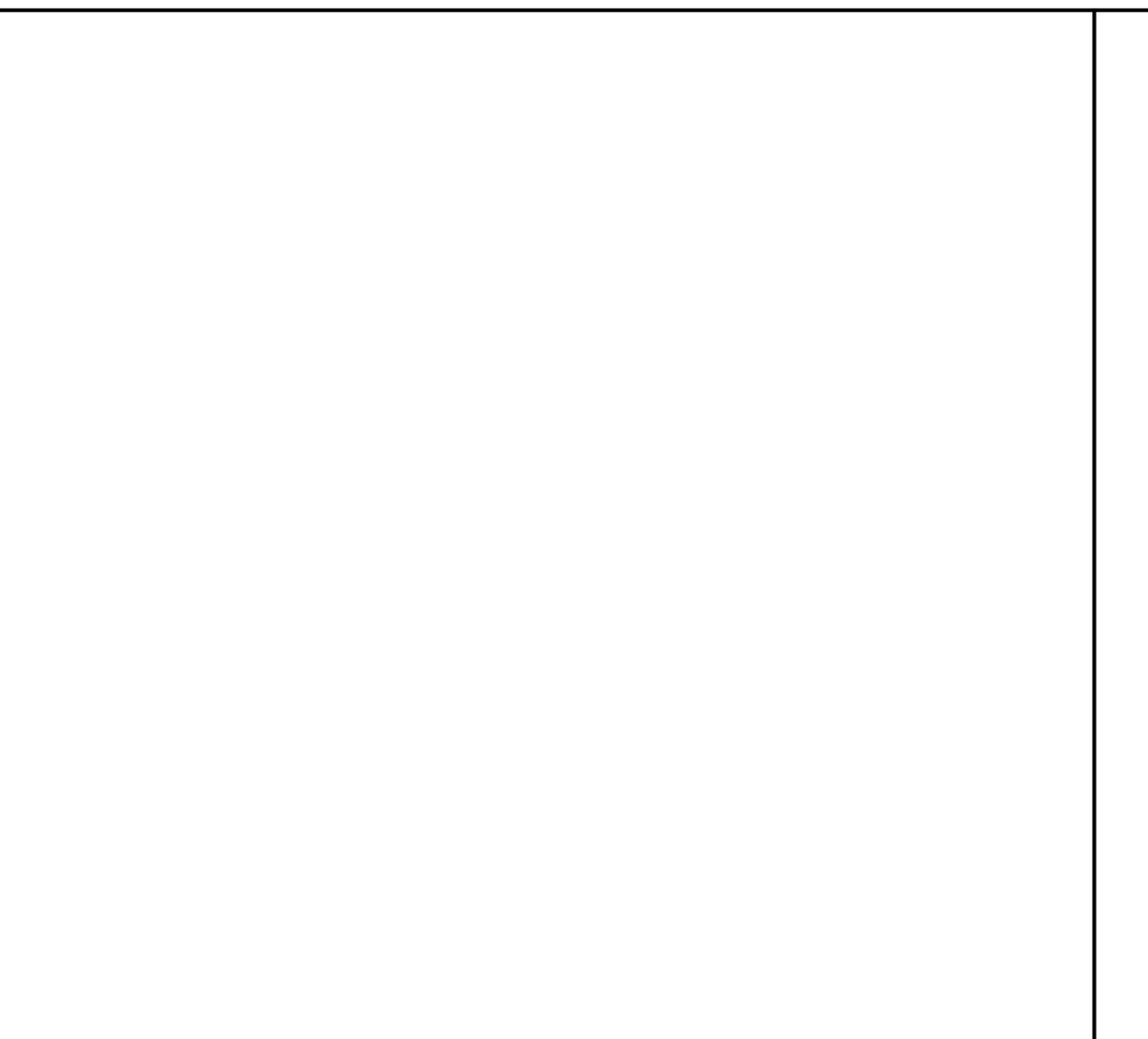
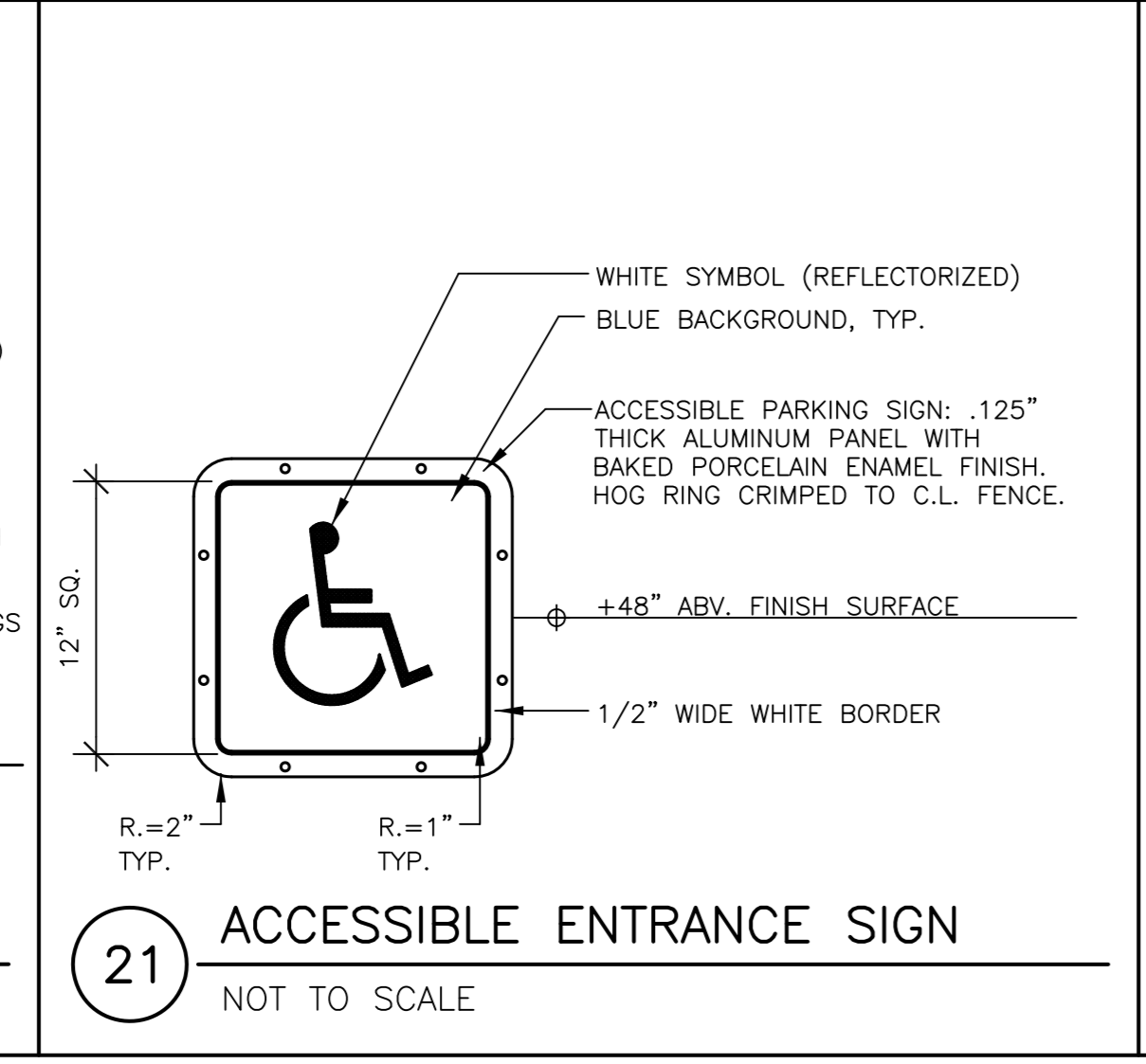
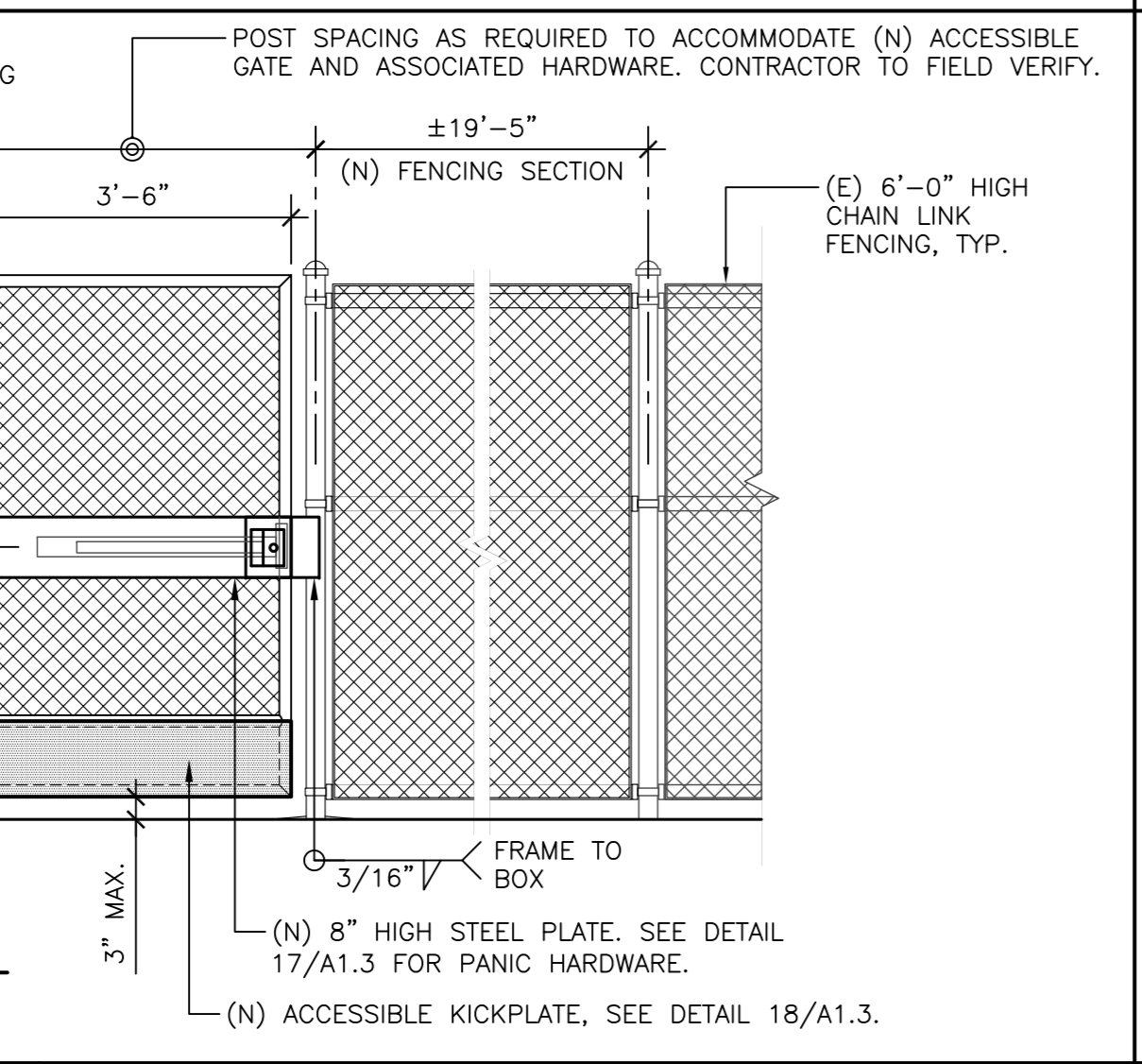
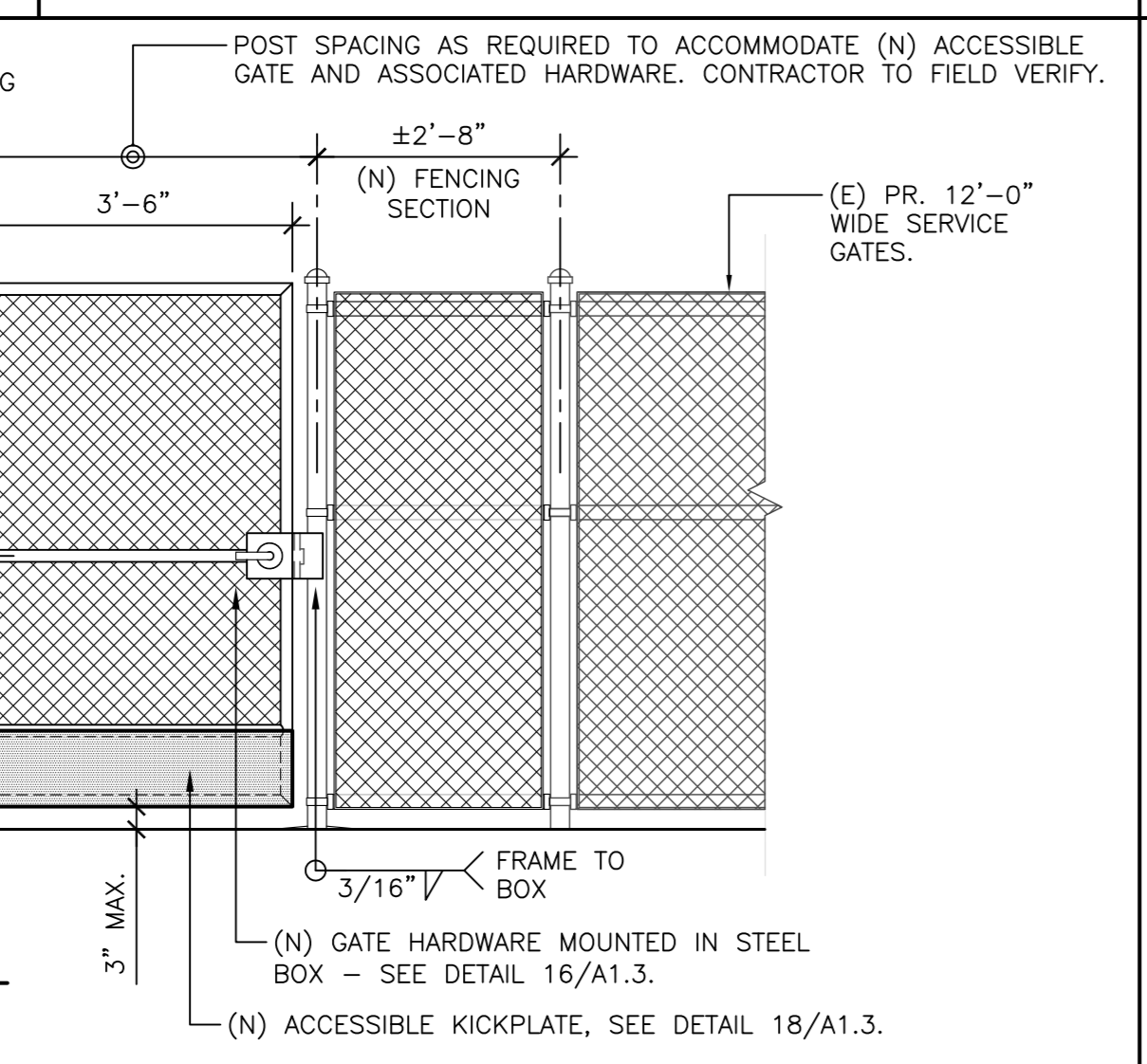
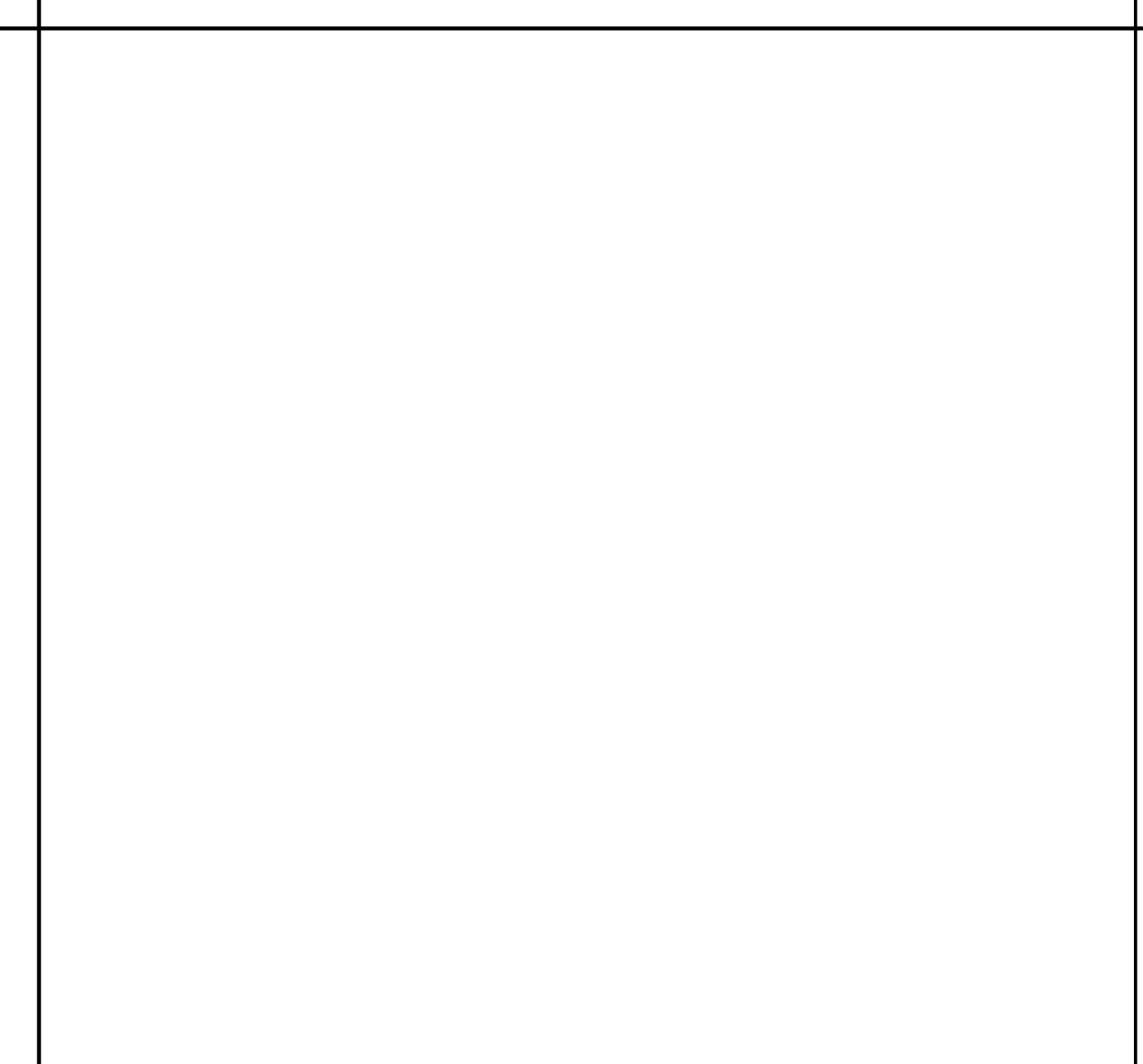
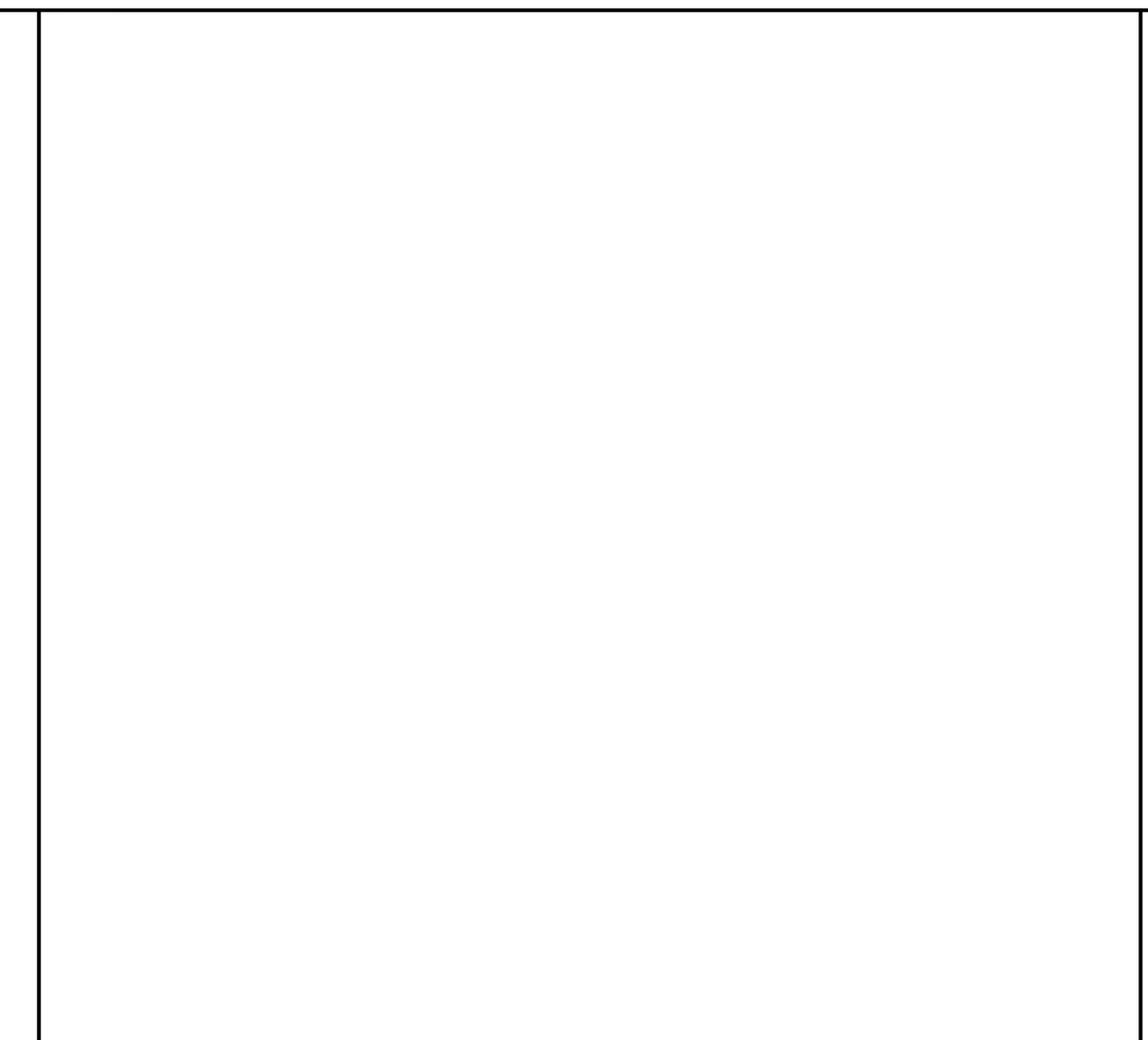
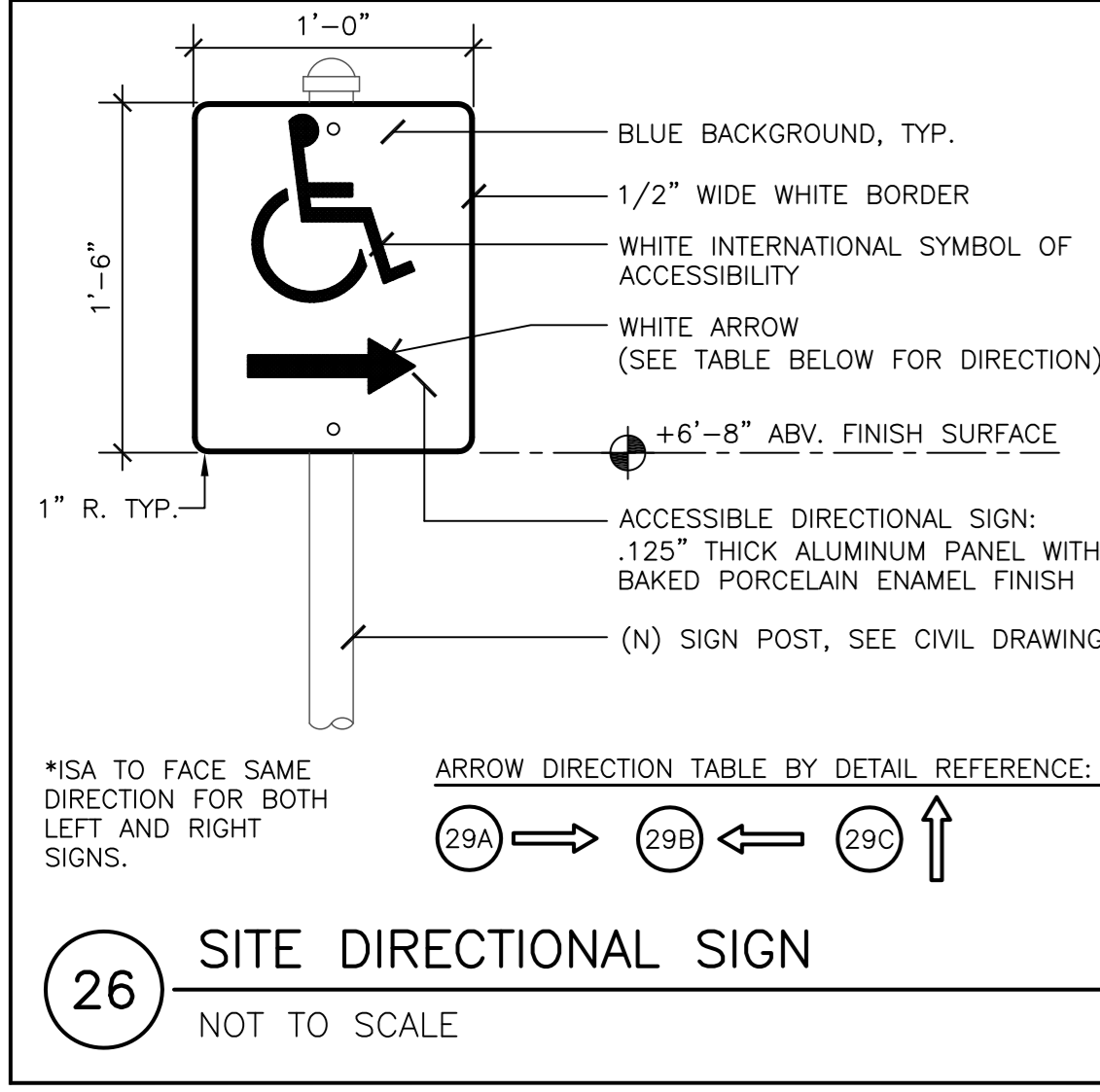
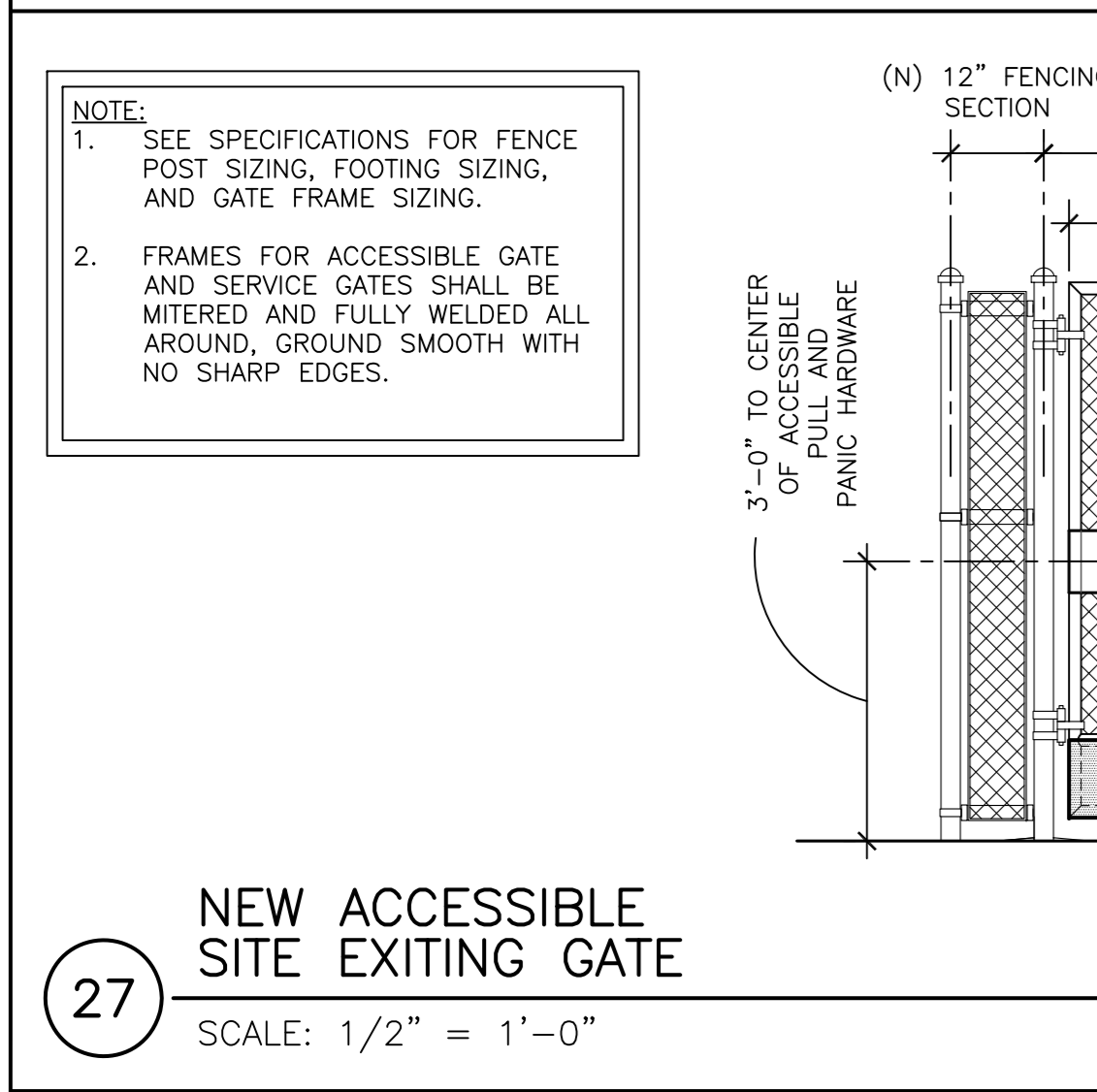
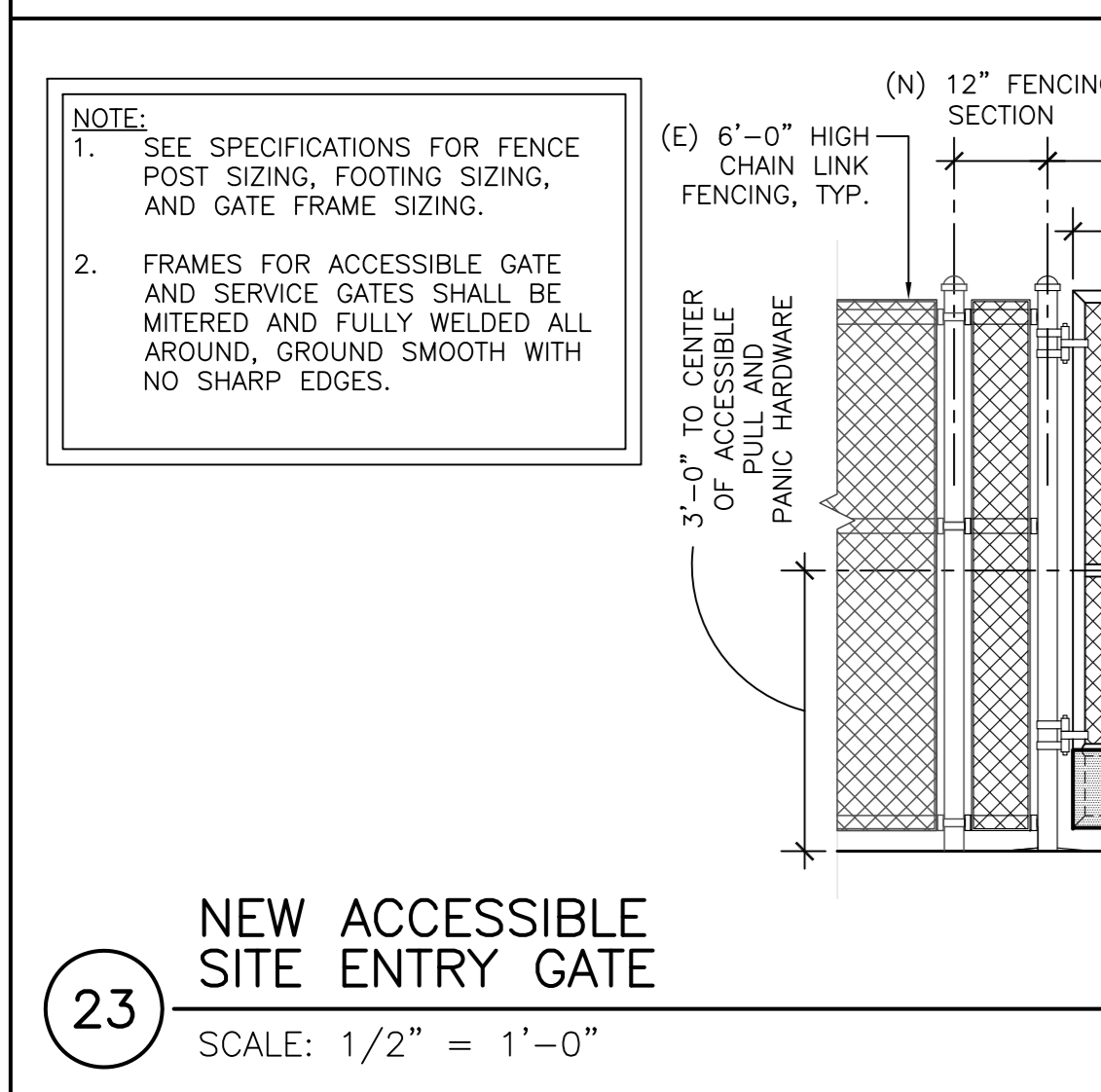
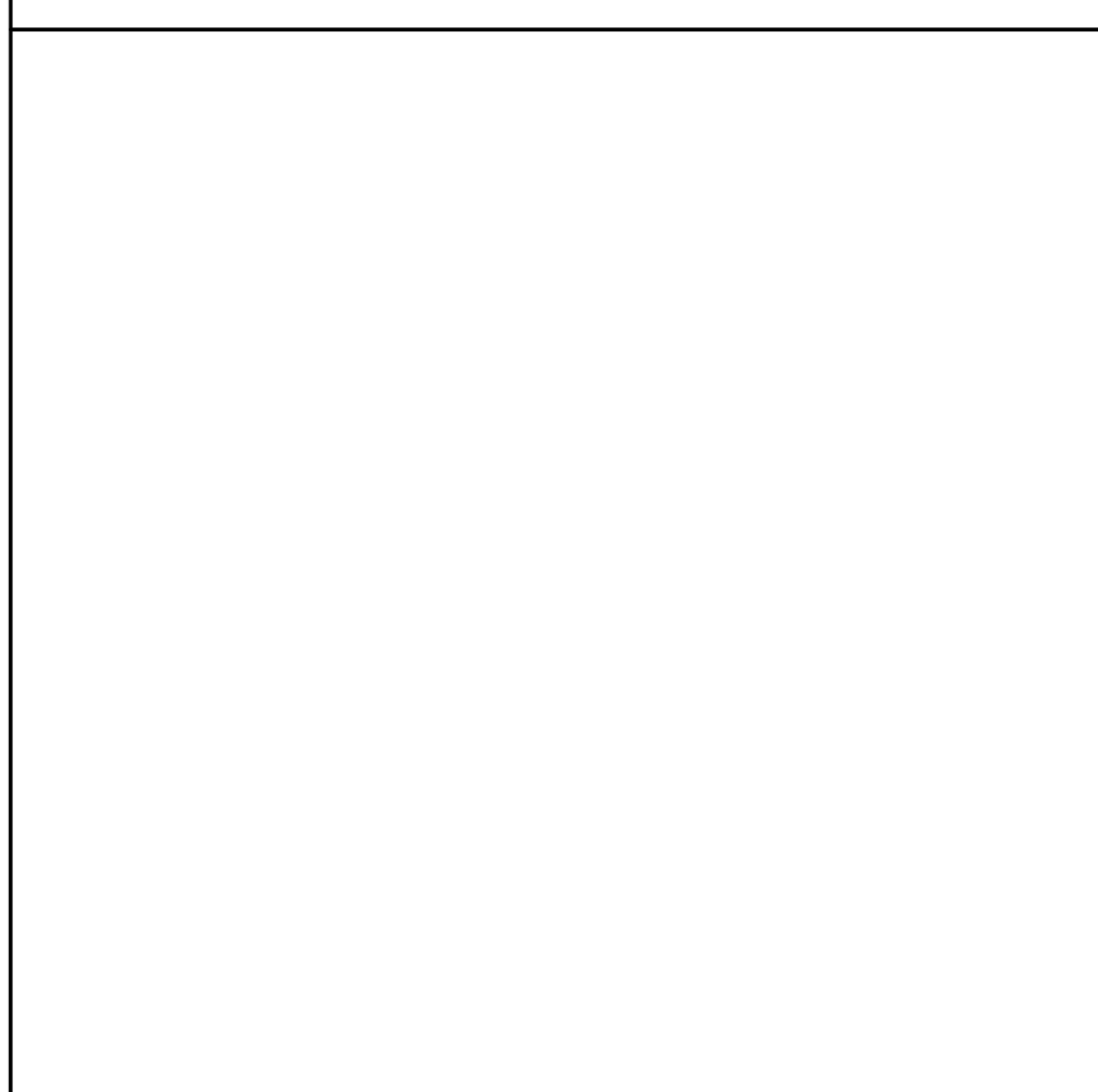
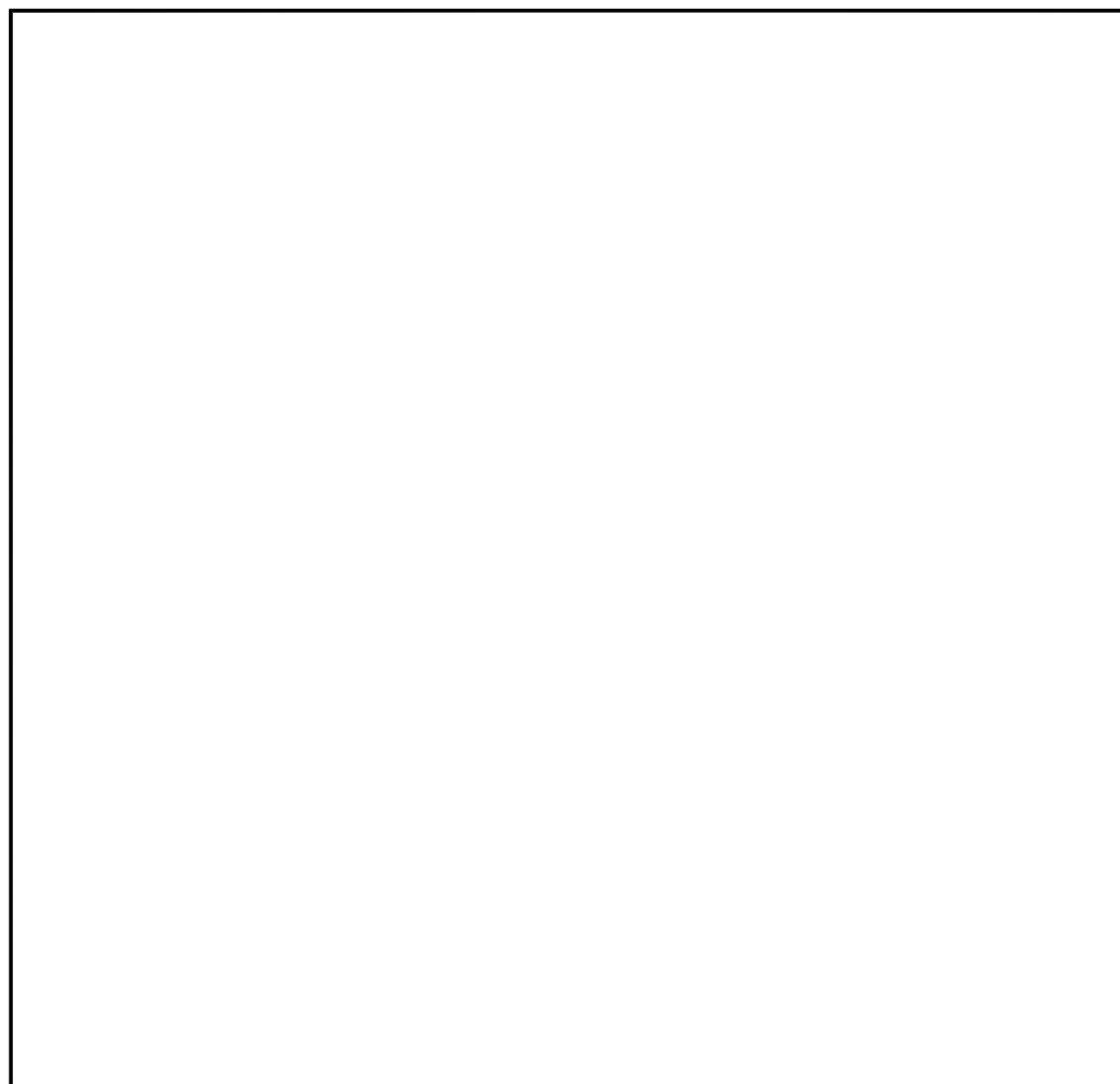

Mt. Diablo High School
Building S - Science Lab Modernization

2450 Grant Street
Concord, California 94520

Mt. Diablo Unified School District

MDUSD

THE STATE ARCHITECT
OFFICE OF REGULATION SERVICES

FILE NO. XX-XX
IDENTIFICATION STAMP
DIV. OF THE STATE ARCHITECT
OFFICE OF REGULATION SERVICES

APPLICATION NO. 01-
AC. FLS. SS
DATE

DIVISION OF THE STATE ARCHITECT
revision date: _____ by: _____

CONSULTANT

nacht&lewis

800 Q Street, Suite 100
Sacramento, CA 95811
www.nachtandlewis.com
916.329.4000

ARCHITECT

REVIEWS		
NO.	DESCRIPTION	DATE REV'D

DATE February 19, 2012
JOB NO. Y1211.00
SHEET TITLE

Site Details

SHEET NO. **A.1.3**

SHEET ___ OF ___ TOTAL
DSA SUBMITTAL SET

ONE AND ONE-HALF INCH = ONE FOOT
 ONE INCH = ONE FOOT
 THREE-QUARTERS INCH = ONE FOOT
 ONE-HALF INCH = ONE FOOT
 ONE-QUARTER INCH = ONE FOOT
 ONE-EIGHTH INCH = ONE FOOT
 ONE-SIXTEENTH INCH = ONE FOOT
 ONE INCH = TWENTY FEET

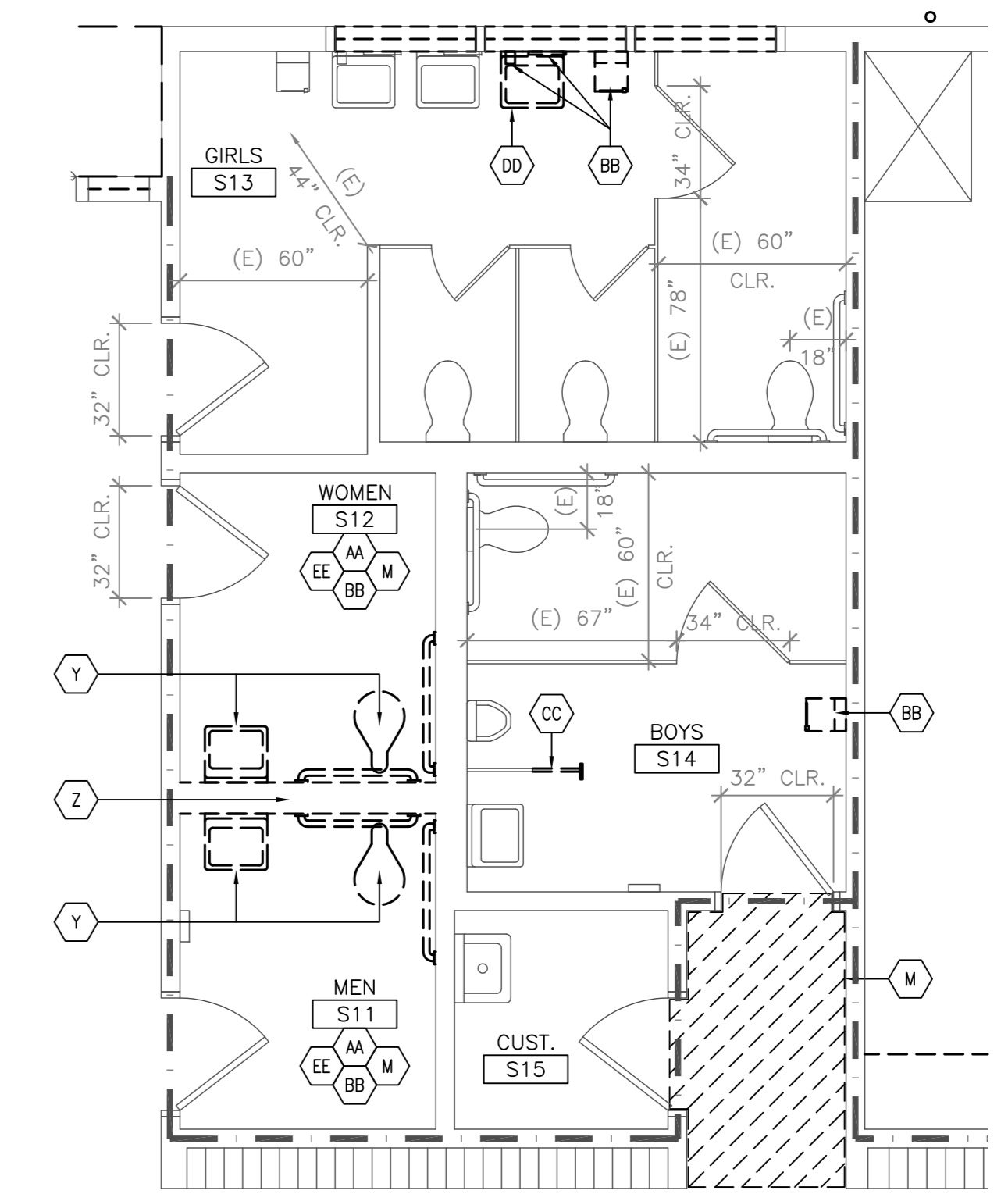

2 Enlarged Demolition Plan
 SCALE: 1/4"=1'-0"

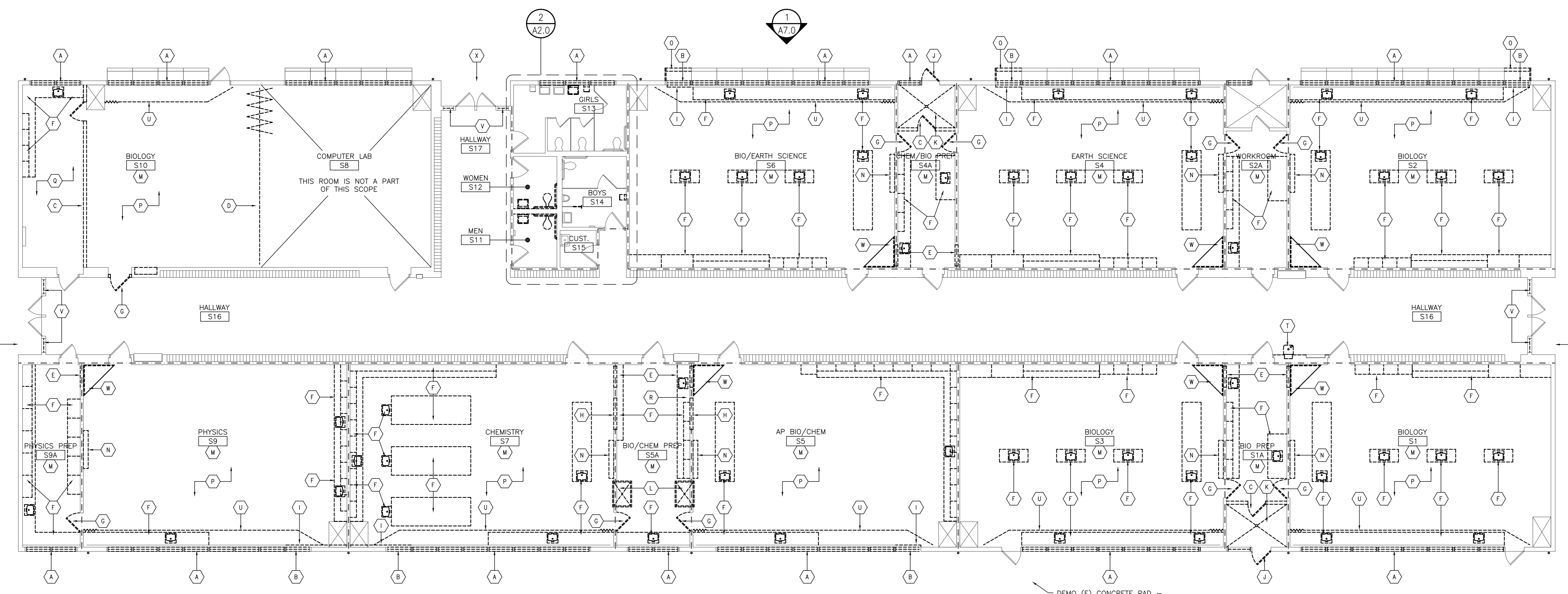

1 Building Demolition Plan
 SCALE: 1/8"=1'-0"

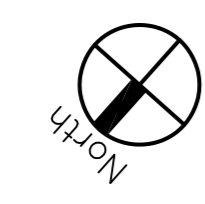

2 A7.0

DEMO (E) CONCRETE PAD - SEE ENLARGED SITE PLAN

DEMOLITION KEYNOTES:

THESE DEMOLITION KEYNOTES APPLY TO THIS SHEET ONLY

- (A) REMOVE EXISTING WINDOW SYSTEM TO ACCOMMODATE NEW WINDOWS. SEE EXTERIOR ELEVATIONS FOR MORE INFORMATION.
- (B) DEMO PORTION OF EXISTING WINDOW SYSTEM, WALL BELOW, AND CONCRETE CURB TO ACCOMMODATE NEW DOOR.
- (C) DEMO WALL, CURB, HEADER, TO BOTTOM OF ROOF FRAMING.
- (D) DEMO OPERABLE PARTITION AND WOOD TRIM BACK TO SOLID FRAMING.
- (E) DEMO PORTION OF WALL FOR NEW DOOR.
- (F) DEMO BASE CABINET, COUNTERTOP, SINK, PLUMBING AND GAS DISTRIBUTION - SALVAGE ALL UPPER WALL-HUNG CABINETS FOR REUSE.
- (G) DEMO DOOR AND FRAME FOR NEW WALL INFILL.
- (H) DEMO PORTION OF WALL FOR NEW FUME HOOD.
- (I) DEMO PORTION OF FURRED CHASE WALL TO ACCOMMODATE NEW DOOR.
- (J) DEMO PORTION OF EXTERIOR WALL, DOOR AND FRAME FOR NEW WALL INFILL.
- (K) DEMO DRAIN CAP BELOW FINISH FLOOR IN MUD ROOM AND FLOAT ENTIRE FLOOR WITH CONCRETE-TYPE LEVELING COMPOUND.
- (L) DEMO FUME HOOD.
- (M) REMOVE/ABATE EXISTING VINYL ASBESTOS TILE WHERE OCCURS AND PREP FLOOR TO RECEIVE NEW VCT RESILIENT FLOORING.
- (N) REMOVE SLIDING MARKER/CHALKBOARD ASSEMBLY.
- (O) REMOVE PORTION OF EXISTING ALUMINUM WINDOW SHADE SCREEN TO ACCOMMODATE NEW DOOR. SEE A7.0 AND A8.2.
- (P) REMOVE (E) 12X24 APPLIED ACOUSTICAL TILE CEILING. 1X FURRING TO REMAIN.
- (Q) REMOVE (E) PLASTER CEILING AND FURRING TO BOTTOM OF ROOF FRAMING.
- (R) DEMO (E) WALL MOUNTED DISTILLED WATER EQUIPMENT, POWER, AND WATER SUPPLY.
- (S) DEMO (E) EMERGENCY SHOWER AND WATER SUPPLY.
- (T) DEMO (E) WALL MOUNTED DRINKING FOUNTAIN, WALL TILE, AND SUBSTRATE AS REQUIRED TO INSTALL (N) DUAL HEIGHT DRINKING FOUNTAIN. SEE DETAIL 26/A8.0.
- (U) DEMO (E) CURTAIN AND CEILING MOUNTED TRACK.
- (V) REMOVE ALL EXISTING 1/4" GLAZING FROM (E) SIDELITES AND UPPER TRANSOM WINDOWS. GLAZING IN DOORS TO REMAIN.
- (W) DEMO (E) WOOD TRIANGLE-SHAPED TV WALL SHELF. PATCH AND REPAIR WALL SURFACE.
- (X) DEMO (E) CONCRETE APRON.
- (Y) REMOVE (E) PLUMBING FIXTURE. STORE FOR REUSE.
- (Z) DEMO (E) NON-BEARING WALL.
- (AA) DEMO PORTIONS OF (E) CONCRETE SLAB AS REQUIRED TO REROUTE PLUMBING.
- (BB) REMOVE (E) TOILET ACCESSORY. STORE FOR REUSE. ALL ACCESSORIES NOT REUSED SHALL BE RETURNED TO DISTRICT.
- (CC) DEMO PORTION OF (E) PARTITION SYSTEM. CUT PANEL TO LENGTH AS SHOWN IN ALTERATION PLAN. REMOVE AND RELOCATE (E) STILE AND OVERHEAD SUPPORT TO (N) LOCATION. PATCH AND REPAIR FLOOR TILE.
- (DD) REMOVE (E) SINK. CAP UTILITIES BEHIND WALL FINISH. SEE PLUMBING DRAWINGS. PATCH & REPAIR (E) WALL TILE TO BEST MATCH (E) ADJACENT FINISH.
- (EE) DEMO (E) 48" HIGH FRP WAINSCOT FROM FULL PERIMETER OF ROOM.

GENERAL SHEET NOTES:

1. SEE MECHANICAL, PLUMBING, ELECTRICAL AND OTHER SHEETS FOR DEMOLITION WORK NOT SHOWN HERE.
2. COORDINATE LOCATIONS OF CONCRETE FLOOR SLAB SAW-CUTTING AND DEMO WITH PLUMBING SCOPE. PROVIDE MOST EFFICIENT LAYOUT AND ROUTING POSSIBLE TO LIMIT AMOUNT OF FLOOR DEMOLITION.
3. AT DEMOLITION OF (E) PLUMBING PIPING AND ELECTRICAL CONDUIT IN (E) CONCRETE FLOOR SLAB, REMOVE AND CAP TO BELOW TOP OF SLAB AND PATCH SMOOTH WITH GROUT OR CONCRETE.
4. REMOVE ALL (E) WALL HUNG FIRE EXTINGUISHERS AND WALL BRACKETS IN LABS AND PREP ROOMS - SALVAGE FOR REUSE.
5. REMOVE ALL LAB UPPER WALL HUNG CABINETS WITH CARE AND SALVAGE FOR REUSE. LABEL ALL CABINETS PRIOR TO REMOVAL AND COORDINATE INTERIOR ELEVATIONS FOR NEW LOCATIONS/CONFIGURATION AND WITH SPECIFICATIONS FOR NEW HARDWARE AND REFINISHING/RECONDITIONING SCOPE.

Mt. Diablo High School
Building S - Science Lab Modernization

2480 Grant Street
 Concord, California 94520

Mt. Diablo Unified School District



FILE NO. XX-XX
 IDENTIFICATION STAMP
 DIV. OF THE STATE ARCHITECT
 OFFICE OF REGULATION SERVICES
 APPLICATION NO. 01-
 AC. FLS. SS
 DATE

DIVISION OF THE STATE ARCHITECT
 revision date: by:

CONSULTANT
nacht&lewis
 600 Q Street, Suite 100
 Sacramento, CA 95811
 www.nachtlewis.com
 916.329.4000

ARCHITECT

REVISIONS		
NO.	DESCRIPTION	DATE REV'D

DATE February 19, 2012
 JOB NO. Y1211.00
 SHEET TITLE

Building Demolition Plan

SHEET NO.
A2.0
 SHEET ___ OF ___ TOTAL
 DSA SUBMITTAL SET

ONE AND ONE-HALF INCH = ONE FOOT
ONE INCH = ONE FOOT
THREE-QUARTERS INCH = ONE FOOT
ONE-HALF INCH = ONE FOOT
ONE-QUARTER INCH = ONE FOOT
ONE-EIGHTH INCH = ONE FOOT
ONE-SIXTEENTH INCH = ONE FOOT
ONE-THIRTYSECOND INCH = ONE FOOT
ONE INCH = TWENTY FEET

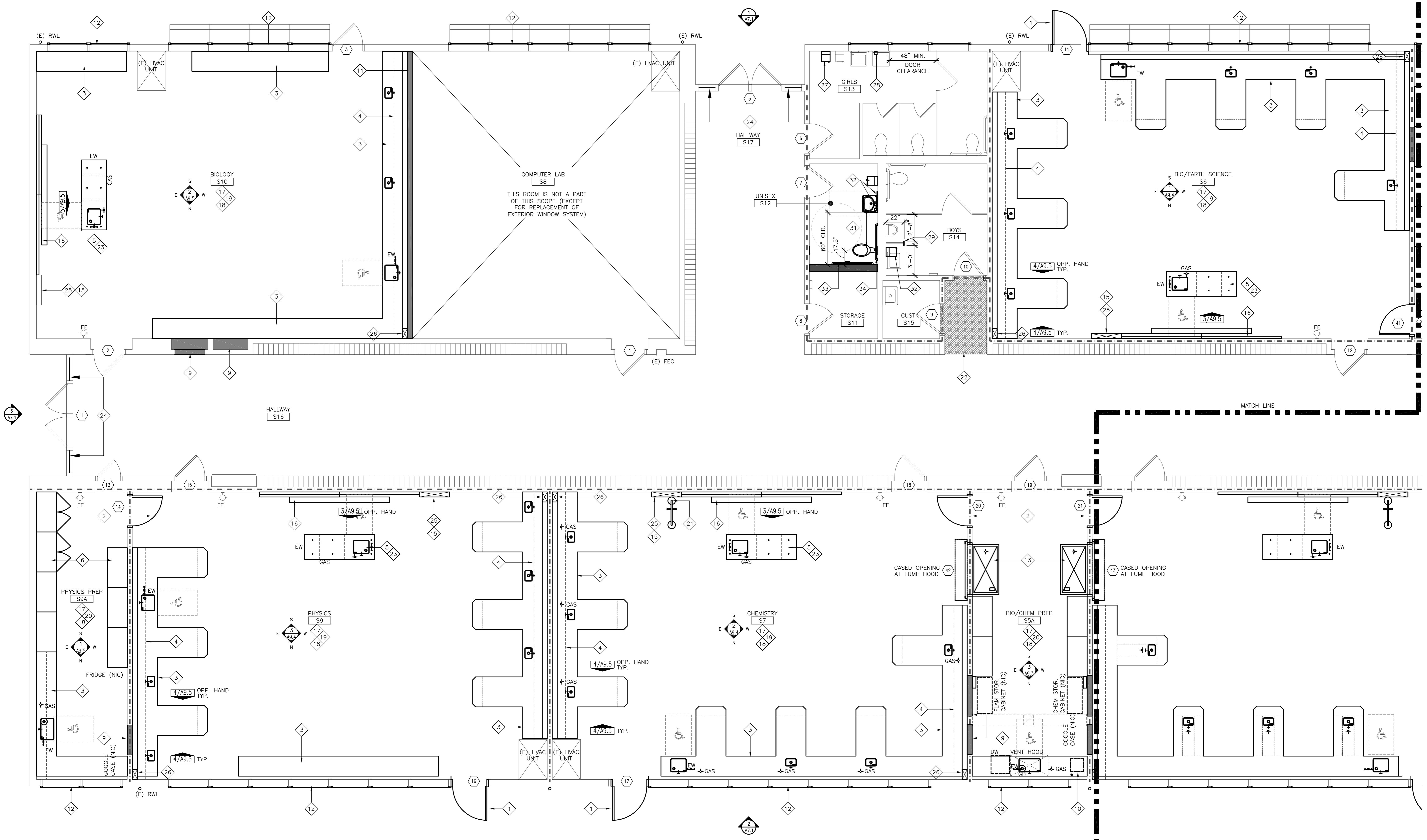

1 Partial Floor Plan - East
SCALE: 1/4"=1'-0"

NEW WORK KEYNOTES:

- THESE NEW WORK KEYNOTES APPLY TO THIS SHEET ONLY
- 1 NEW DOOR IN EXTERIOR WINDOW WALL - SEE OPENING SCHEDULE FOR DETAIL REFERENCES.
 - 2 NEW DOOR IN INTERIOR WALL - SEE OPENING SCHEDULE FOR DETAIL REFERENCES.
 - 3 PLASTIC LAMINATE BASE CABINETS WITH CHEMICAL/HEAT RESISTANT RESIN COUNTERTOPS.
 - 4 SALVAGED AND REFINISHED UPPER WALL CABINETS - SEE INTERIOR ELEVATIONS.
 - 5 INSTRUCTOR'S DEMONSTRATION TABLE WITH CHEMICAL/HEAT RESISTANT COUNTERTOP & SINK.
 - 6 PLASTIC LAMINATE OPEN SHELVING UNIT WITH ADJUSTABLE SHELVES - SEE INTERIOR ELEVATIONS.
 - 7 NOT USED.
 - 8 NOT USED.
 - 9 INFILL EXISTING INTERIOR WALL WITH NEW FINISHES TO MATCH EXISTING.
 - 10 DISTILLED WATER SYSTEM - SEE PLUMBING DRAWINGS AND SPECIFICATIONS.
 - 11 NEW 2X6 WOOD STUD WALL WITH 5/8" GYP. BOARD EACH SIDE. PROVIDE BATT INSULATION AT ALL STUD CAVITIES. PROVIDE (N) RESILIENT BASE.

- 12 NEW ALUMINUM EXTERIOR WINDOW SYSTEM WITH DUAL-PANE INSULATED GLAZING - TYPICAL ALL EXTERIOR WINDOWS EXCEPT MAIN HALLWAY ENTRY DOORS (3 LOCATIONS) SEE EXTERIOR ELEVATIONS.
- 13 NEW PASS-THRU DEMONSTRATION FUME HOOD.
- 14 PLASTIC LAMINATE BASE CABINET, COUNTERTOP & UPPER WALL CABINETS.
- 15 ROOM GAS SHUT OFF VALVE IN LOCKABLE WALL BOX - SEE PLUMBING DRAWINGS.
- 16 NEW MARKERBOARD & PROJECTION SCREEN.
- 17 NEW VCT RESILIENT FLOORING & RESILIENT BASE.
- 18 PATCH & REPAIR ALL WALL SURFACES, PROVIDE NEW TACKABLE VINYL WALL PANEL WAINSCOT AND PAINT BALANCE OF EXPOSED WALL SURFACES - SEE INTERIOR ELEVATIONS.
- 19 NEW 12"x12" ACOUSTICAL TILE CEILING ON EXISTING FURRING SEE REFLECTED CEILING PLANS.
- 20 PATCH & REPAIR ALL CEILING SURFACES - PAINT.
- 21 NEW EMERGENCY SHOWER/EYEWASH COMBO UNIT.
- 22 REMOVE AND REPLACE PORTION OF (E) VCT FLOORING AND (E) 4" RESILIENT BASE.

- 23 AT NEW EPOXY SINK, PROVIDE SINK CLOSURE PANEL TO PROVIDE FLAT WORKING SURFACE WHEN SINK NOT IN USE - SEE DETAIL 16/AB.0.
- 24 (N) 1/4" CLEAR TEMPERED GLAZING.
- 25 (N) UTILITY CHASE TYPE "A" - SEE DETAIL 6/AB.0.
- 26 (N) UTILITY CHASE TYPE "B" - SEE DETAIL 7/AB.0.
- 27 INSTALL (N) PAPER TOWEL DISPENSER AT 40" MAX. A.F.F. TO CENTER OF DISPENSER OUTLET.
- 28 RELOCATED SOAP DISPENSER, INSTALL AT 40" MAX. A.F.F. TO CENTER OF DISPENSER OUTLET.
- 29 REINSTALL (E) STILE AND OVERHEAD SUPPORT IN (N) LOCATION
- 30 PATCH & REPAIR (E) FLOOR TILE TO BEST MATCH (E) ADJACENT TILES AT RELOCATED PARTITION STILE.
- 31 REINSTALLED PLUMBING FIXTURE - SEE PLUMBING DRAWINGS.
- 32 REUSE ALL TOILET ACCESSORIES. MOUNTING HEIGHTS PER DETAIL 26/AB.3.
- 33 (E) 42" GRAB BAR TO BE REINSTALLED. PROVIDE NEW BLOCKING PER DETAIL 20/AB.0.
- 34 (E) 36" GRAB BAR TO BE REINSTALLED. PROVIDE NEW BLOCKING PER DETAIL 20/AB.0.

GENERAL SHEET NOTES

1. CONTRACTOR SHALL REMOVE AND REINSTALL (1) PENCIL SHARPENER AND (1) HAND SANITIZER STATION PER CLASSROOM.
2. ALL FIRE EXTINGUISHERS (FE) SHOWN ARE TO BE SALVAGED FROM (E) BUILDING AND REINSTALLED WHERE SHOWN HEREIN.
3. FOR STANDARD EQUIPMENT MOUNTING HEIGHTS, SEE DETAIL X/A9.6.
4. FOR LAYOUT AND CONFIGURATION OF NEW AND SALVAGED CASEWORK, SEE INTERIOR ELEVATIONS AND CASEWORK DETAILS.
5. CONTRACTOR TO FIELD VERIFY ALL ROOM DIMENSIONS WITH CASEWORK SCOPE OF WORK PRIOR TO PREPARATION OF CASEWORK SHOP DRAWINGS.

LEGEND

- - - - - EXISTING 1-HOUR RATED WALL CONSTRUCTION. ALL NEW PENETRATIONS THAT PASS THROUGH RATED WALLS SHALL BE FULLY FIRE SEALED.

KEYPLAN:

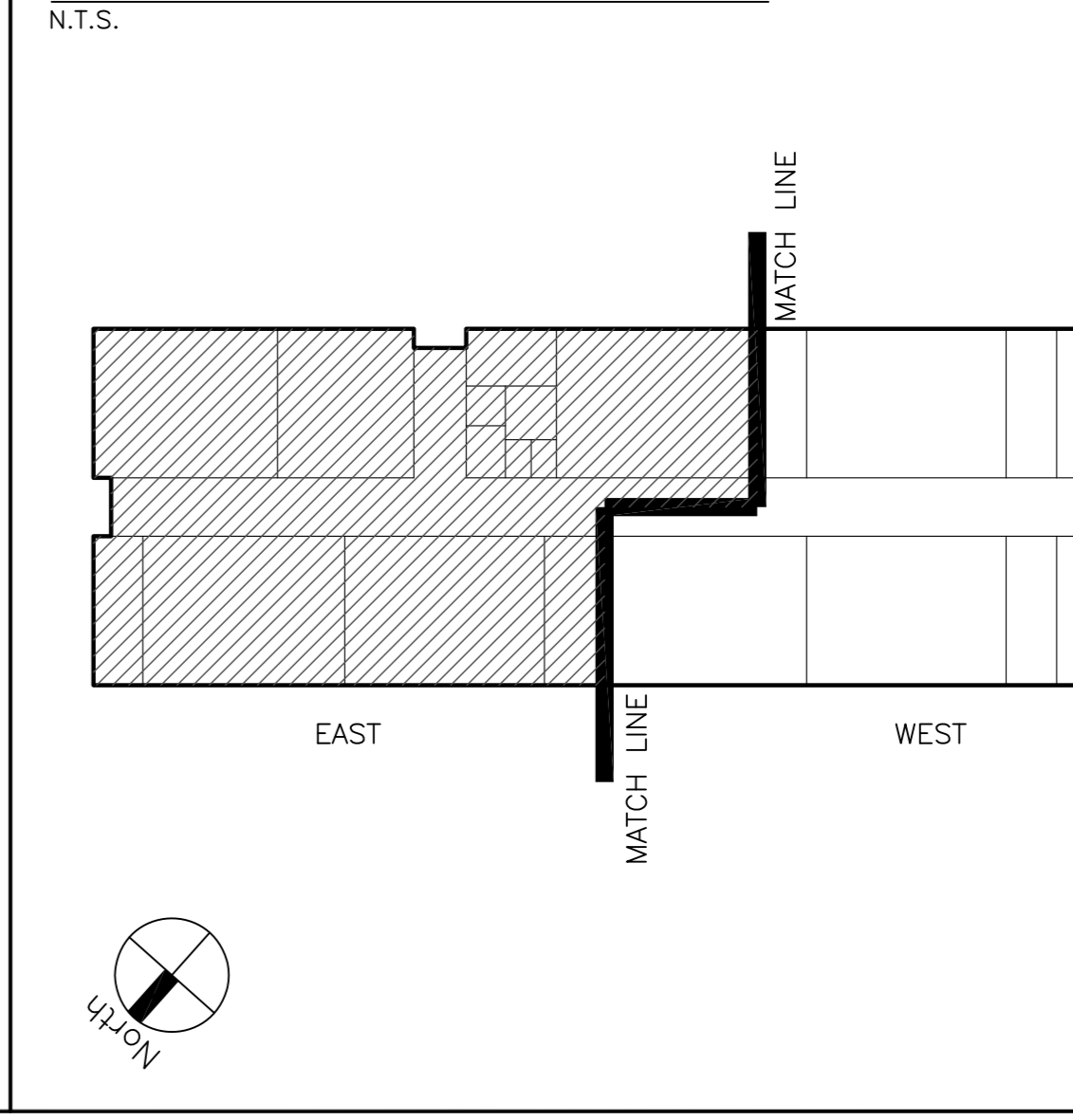

Mt. Diablo High School
Building S - Science Lab Modernization
 2450 Grant Street
 Concord, California 94520
Mt. Diablo Unified School District



FILE NO. XX-XX
 IDENTIFICATION STAMP
 DIV. OF THE STATE ARCHITECT
 OFFICE OF REGULATION SERVICES
 APPLICATION NO. 01-
 AC. FLS. SS
 DATE

DIVISION OF THE STATE ARCHITECT
 revision date: by:

CONSULTANT
nacht & lewis
 600 O Street, Suite 100
 Sacramento, CA 95811
 www.nachtlewis.com
 916.329.4000

ARCHITECT

REVISIONS		
NO.	DESCRIPTION	DATE / REV'D

DATE February 19, 2012
 JOB NO. Y1211.00
 SHEET TITLE
Partial Floor Plan East
 SHEET NO.
A3.0
 SHEET ___ OF ___ TOTAL
 DSA SUBMITTAL SET

ONE AND ONE-HALF INCH = ONE FOOT
ONE INCH = ONE FOOT
THREE-QUARTERS INCH = ONE FOOT
ONE-HALF INCH = ONE FOOT
ONE-QUARTER INCH = ONE FOOT
ONE-EIGHTH INCH = ONE FOOT
ONE-SIXTEENTH INCH = ONE FOOT
ONE INCH = TWENTY FEET

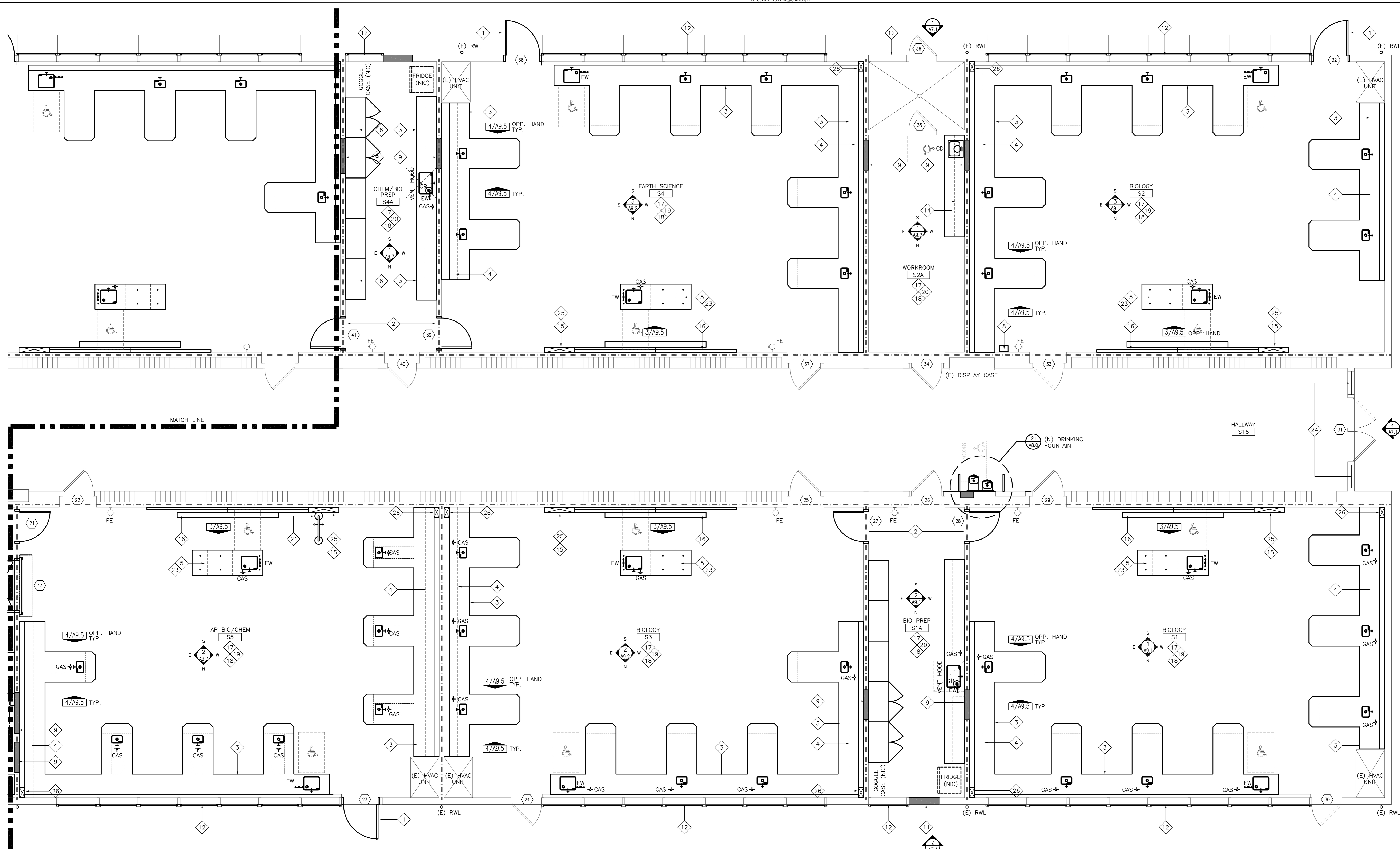

1 Partial Floor Plan - West
SCALE: 1/4"=1'-0"

NEW WORK KEYNOTES:
THESE NEW WORK KEYNOTES APPLY TO THIS SHEET ONLY

- 1 NEW DOOR IN EXTERIOR WINDOW WALL - SEE OPENING SCHEDULE FOR DETAIL REFERENCES.
- 2 NEW DOOR IN INTERIOR WALL - SEE OPENING SCHEDULE FOR DETAIL REFERENCES.
- 3 PLASTIC LAMINATE BASE CABINETS WITH CHEMICAL/HEAT RESISTANT RESIN COUNTERTOPS.
- 4 SALVAGED AND REFINISHED UPPER WALL CABINETS - SEE INTERIOR ELEVATIONS.
- 5 INSTRUCTOR'S DEMONSTRATION TABLE WITH CHEMICAL/HEAT RESISTANT COUNTERTOP & SINK.
- 6 PLASTIC LAMINATE OPEN SHELVING UNIT WITH ADJUSTABLE SHELVES - SEE INTERIOR ELEVATIONS.
- 7 NOT USED.
- 8 NOT USED.
- 9 INFILL EXISTING INTERIOR WALL WITH NEW FINISHES TO MATCH EXISTING.
- 10 DISTILLED WATER SYSTEM - SEE PLUMBING DRAWINGS AND SPECIFICATIONS.
- 11 NEW 2X6 WOOD STUD WALL WITH 5/8" GYP. BOARD EACH SIDE. PROVIDE BATT INSULATION AT ALL STUD CAVITIES. PROVIDE (N)

- 12 NEW ALUMINUM EXTERIOR WINDOW SYSTEM WITH DUAL-PANE INSULATED GLAZING - TYPICAL ALL EXTERIOR WINDOWS EXCEPT MAIN HALLWAY ENTRY DOORS (3 LOCATIONS) SEE EXTERIOR ELEVATIONS.
- 13 NEW PASS-THRU DEMONSTRATION FUME HOOD.
- 14 PLASTIC LAMINATE BASE CABINET, COUNTERTOP & UPPER WALL CABINETS.
- 15 ROOM GAS SHUT OFF VALVE IN LOCKABLE WALL BOX - SEE PLUMBING DRAWINGS.
- 16 NEW MARKERBOARD & PROJECTION SCREEN.
- 17 NEW VCT RESILIENT FLOORING & RESILIENT BASE.
- 18 PATCH & REPAIR ALL WALL SURFACES, PROVIDE NEW TACKABLE VINYL WALL PANEL WAINSCOT AND PAINT BALANCE OF EXPOSED WALL SURFACES - SEE INTERIOR ELEVATIONS.
- 19 NEW 12"x12" ACOUSTICAL TILE CEILING ON EXISTING FURRING SEE REFLECTED CEILING PLANS.
- 20 PATCH & REPAIR ALL CEILING SURFACES - PAINT.
- 21 NEW EMERGENCY SHOWER/EYEWASH COMBO UNIT.
- 22 REMOVE AND REPLACE PORTION OF (E) VCT FLOORING AND (E) 4" RESILIENT BASE.

- 23 AT NEW EPOXY SINK, PROVIDE SINK CLOSURE PANEL TO PROVIDE FLAT WORKING SURFACE WHEN SINK NOT IN USE - SEE DETAIL 16/A8.0.
- 24 (N) 1/4" CLEAR TEMPERED GLAZING.
- 25 (N) UTILITY CHASE TYPE "A" - SEE DETAIL 6/A8.0
- 26 (N) UTILITY CHASE TYPE "B" - SEE DETAIL 7/A8.0
- 27 INSTALL (N) PAPER TOWEL DISPENSER AT 40" MAX. A.F.F. TO CENTER OF DISPENSER OUTLET.
- 28 RELOCATED SOAP DISPENSER, INSTALL AT 40" MAX. A.F.F. TO CENTER OF DISPENSER OUTLET.
- 29 REINSTALL (E) STILE AND OVERHEAD SUPPORT IN (N) LOCATION
- 30 PATCH & REPAIR (E) FLOOR TILE TO BEST MATCH (E) ADJACENT TILES AT RELOCATED PARTITION STILE.
- 31 REINSTALLED PLUMBING FIXTURE - SEE PLUMBING DRAWINGS.
- 32 REUSE ALL TOILET ACCESSORIES. MOUNTING HEIGHTS PER DETAIL 26/A6.3.
- 33 (E) 42" GRAB BAR TO BE REINSTALLED. PROVIDE NEW BLOCKING PER DETAIL 20/A8.0.
- 34 (E) 36" GRAB BAR TO BE REINSTALLED. PROVIDE NEW BLOCKING PER DETAIL 20/A8.0.

GENERAL SHEET NOTES

1. CONTRACTOR SHALL REMOVE AND REINSTALL (1) PENCIL SHARPENER AND (1) HAND SANITIZER STATION PER CLASSROOM.
2. ALL FIRE EXTINGUISHERS (FE) SHOWN ARE TO BE SALVAGED FROM (E) BUILDING AND REINSTALLED WHERE SHOWN HEREIN.
3. FOR STANDARD EQUIPMENT MOUNTING HEIGHTS, SEE DETAIL X/A9.6.
4. FOR LAYOUT AND CONFIGURATION OF NEW AND SALVAGED CASEWORK, SEE INTERIOR ELEVATIONS AND CASEWORK DETAILS.
5. CONTRACTOR TO FIELD VERIFY ALL ROOM DIMENSIONS WITH CASEWORK SCOPE OF WORK PRIOR TO PREPARATION OF CASEWORK SHOP DRAWINGS.

LEGEND

--- EXISTING 1-HOUR RATED WALL CONSTRUCTION. ALL NEW PENETRATIONS THAT PASS THROUGH RATED WALLS SHALL BE FULLY FIRE SEALED.

KEYPLAN:
N.T.S.

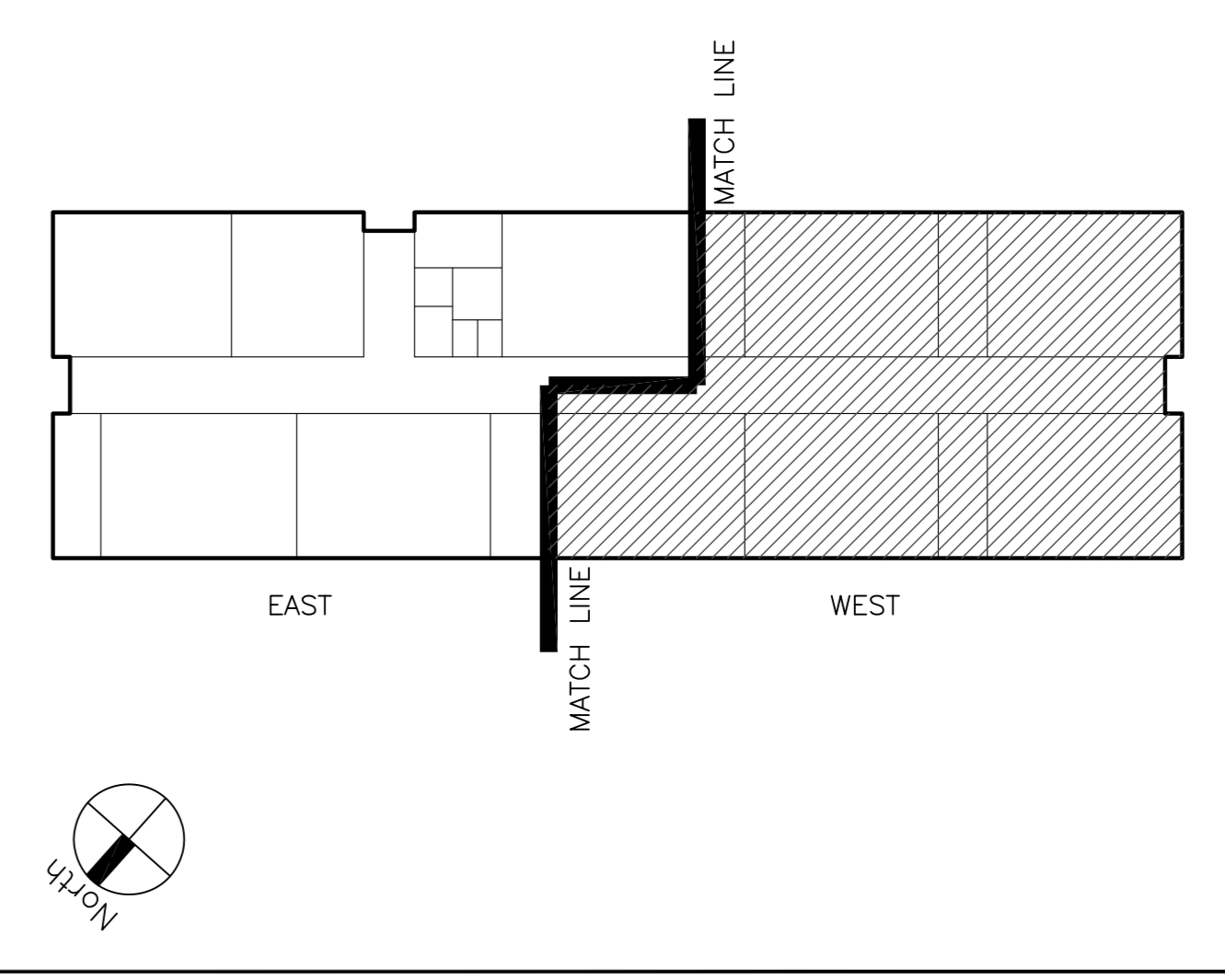

Mt. Diablo High School
Building S - Science Lab Modernization
2480 Grant Street
Concord, California 94520
Mt. Diablo Unified School District



FILE NO. XX-XX
IDENTIFICATION STAMP
DIV. OF THE STATE ARCHITECT
OFFICE OF REGULATION SERVICES
APPLICATION NO. 01-
AC. FLS. SS
DATE

DIVISION OF THE STATE ARCHITECT
revision date: by:

CONSULTANT
nacht&lewis
600 Q Street, Suite 100
Sacramento, CA 95811
www.nachtlewis.com
916.329.4000

ARCHITECT
REVISIONS
NO. DESCRIPTION DATE REV'D
DATE February 19, 2012
JOB NO. Y1211.00
SHEET TITLE
Partial Floor Plan West
SHEET NO.
A3.1
SHEET ___ OF ___ TOTAL
DSA SUBMITTAL SET

ONE AND ONE-HALF INCH = ONE FOOT
ONE INCH = ONE FOOT
THREE-QUARTERS INCH = ONE FOOT
ONE-HALF INCH = ONE FOOT
ONE-QUARTER INCH = ONE FOOT
ONE-EIGHTH INCH = ONE FOOT
ONE-SIXTEENTH INCH = ONE FOOT
ONE INCH = TWENTY FEET

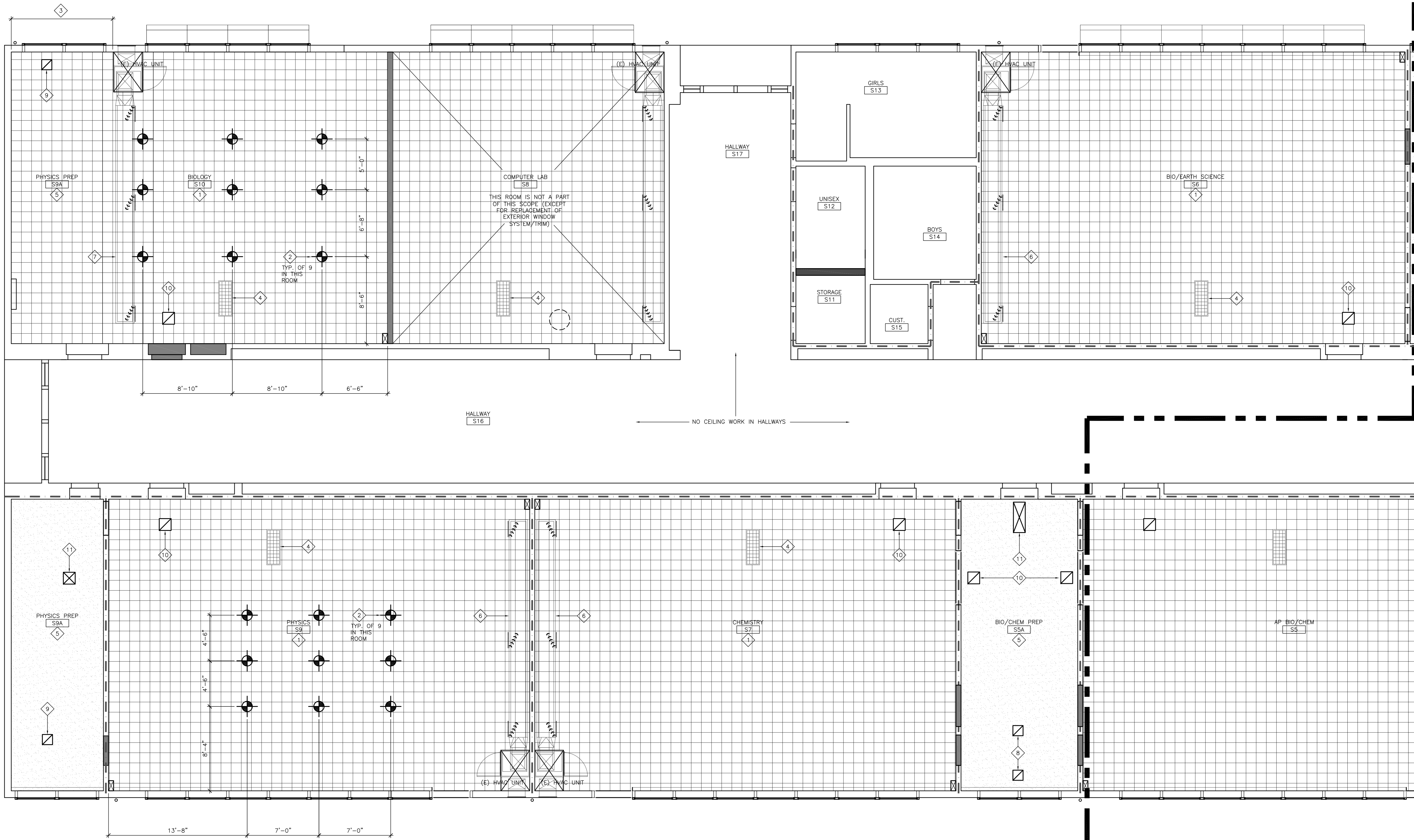

1 Partial Reflected Ceiling Plan - East
SCALE: 1/4"=1'-0"

- NEW WORK KEYNOTES:**
THESE NEW WORK KEYNOTES APPLY TO THIS SHEET ONLY
- 1 REMOVE (E) 12X24 SURFACE MOUNTED CEILING TILES AND REPLACE WITH (N) 12X12 CEILING TILES. PROVIDE ALLOWANCE TO REPLACE 10% OF THE (E) 1x WOOD STRIPING IN EACH LOCATION.
 - 2 PROVIDE (N) CORD REEL MOUNTING BRACKETS - SEE DETAIL 18/A8.0. PROVIDE NEW 1x WOOD STRIPING TO BOTTOM OF (E) ROOF FRAMING IN THIS AREA WHERE (E) HARD LID CEILING WAS REMOVED. HEIGHT AND CONFIGURATION TO MATCH (E) ADJACENT ROOM FOR NEW CONTINUOUS CEILING FINISH.
 - 3 (E) ROOM RELIEF AIR VENT - REMOVE AND REINSTALL GRILL AS NEEDED TO ACCOMMODATE NEW CEILING TILES.
 - 4 PATCH AND REPAIR (E) PLASTER CEILING AT ALL AREAS OF DEMOLITION AND NEW WORK/PREP AND PAINT.
 - 5 (E) CEILING SUSPENDED EXPOSED DUCTWORK - REMOVE AND REINSTALL AS REQUIRED FOR NEW CEILING AND WALL WORK.
 - 6 (E) WALL MOUNTED EXPOSED DUCTWORK - REMOVE AND REINSTALL WITH SUSPENDED MOUNTING - SEE MECHANICAL DRAWINGS.
 - 7 NEW VENT OR FUME HOOD EXHAUST PENETRATION THROUGH (E) CEILING. PATCH AND REPAIR AS REQUIRED.
 - 8 NEW CEILING FAN - SEE MECHANICAL.
 - 9 EXHAUST AIR GRILL - SEE MECHANICAL.
 - 10 SUPPLY AIR GRILL - SEE MECHANICAL.

- GENERAL NOTES**
- 1. CONTRACTOR SHALL REMOVE AND REINSTALL ALL CEILING MOUNTED EQUIPMENT AS REQUIRED TO REPLACE CEILING TILES. THIS INCLUDES ALL LIGHTING, SURFACE MOUNTED RACEWAY FOR FIRE ALARM AND VENTILATION SYSTEMS, CURTAIN CEILING TRACKS, ETC. WORK AROUND (E) SUSPENDED GAS PIPING.

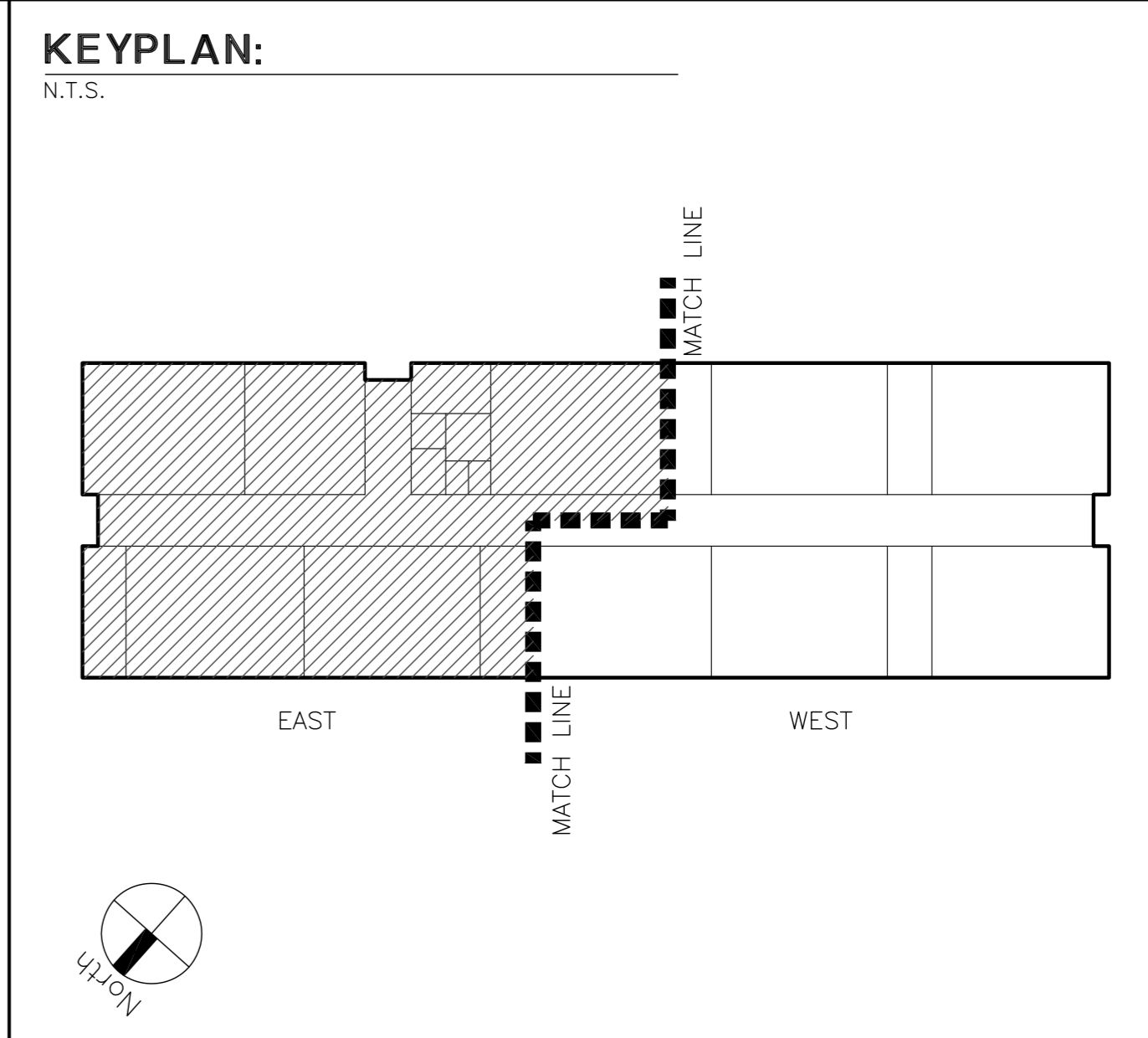

Mt. Diablo High School
Building S - Science Lab Modernization

2480 Grant Street
Concord, California 94520

Mt. Diablo Unified School District



FILE NO. XX-XX
IDENTIFICATION STAMP
DIV. OF THE STATE ARCHITECT
OFFICE OF REGULATION SERVICES
APPLICATION NO. 01-
AC. FLS. SS
DATE

DIVISION OF THE STATE ARCHITECT
revision date: by:

CONSULTANT

nacht&lewis
600 Q Street, Suite 100
Sacramento, CA 95811
www.nachtandlewis.com
916.329.4000

ARCHITECT

REVISIONS		
NO.	DESCRIPTION	DATE / REV

DATE February 19, 2012
JOB NO. Y1211.00
SHEET TITLE
Partial Reflected Ceiling Plan East
SHEET NO.
A4.0
SHEET ___ OF ___ TOTAL
DSA SUBMITTAL SET

ONE AND ONE-HALF INCH = ONE FOOT
ONE INCH = ONE FOOT
THREE-QUARTERS INCH = ONE FOOT
ONE-HALF INCH = ONE FOOT
ONE-QUARTER INCH = ONE FOOT
ONE-EIGHTH INCH = ONE FOOT
ONE-SIXTEENTH INCH = ONE FOOT
ONE INCH = TWENTY FEET

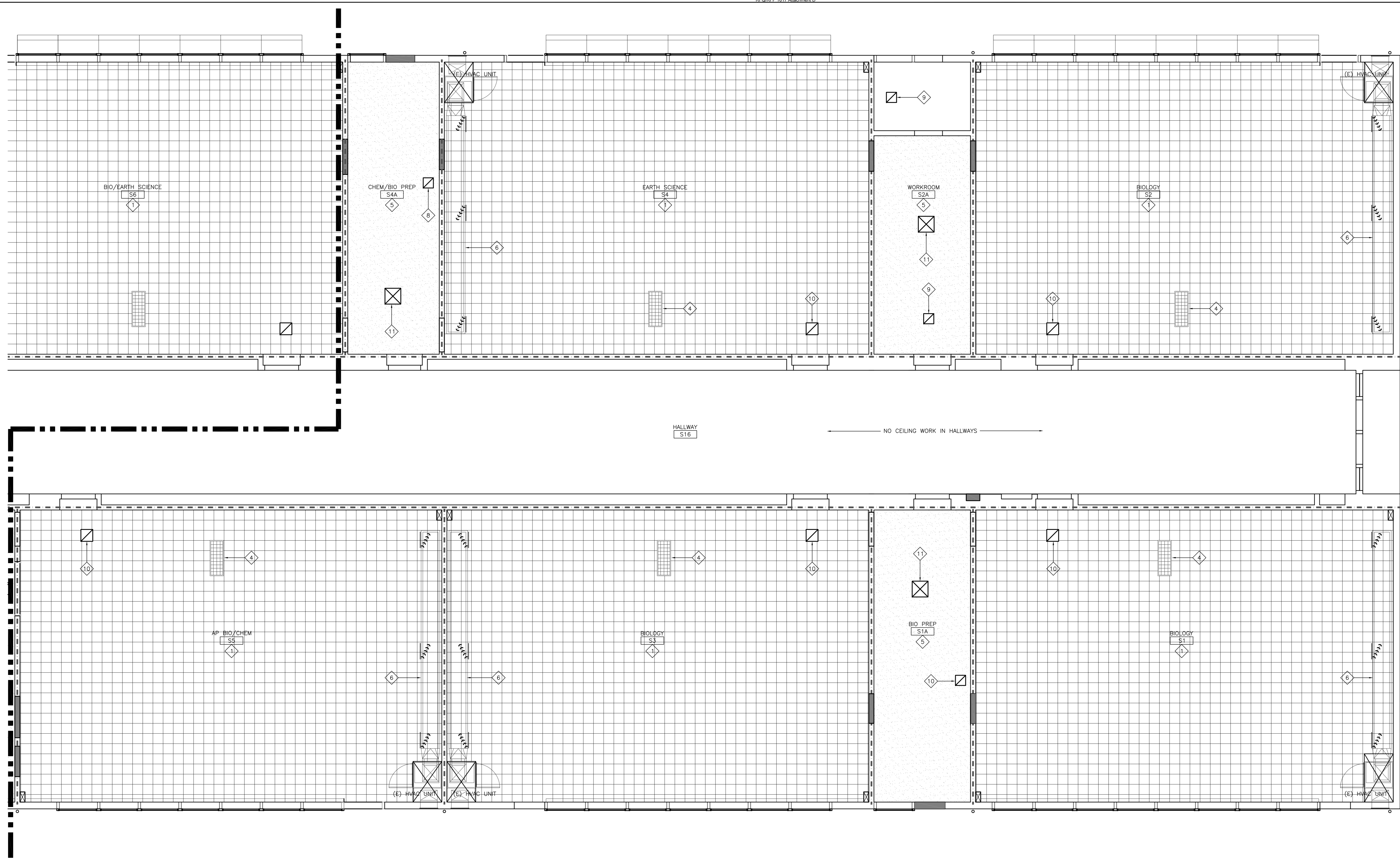

1 Partial Reflected Ceiling Plan - West
SCALE: 1/4"=1'-0"

NEW WORK KEYNOTES:

THESE NEW WORK KEYNOTES APPLY TO THIS SHEET ONLY

- 1 REMOVE (E) 12X24 SURFACE MOUNTED CEILING TILES AND REPLACE WITH (N) 12X12 CEILING TILES. PROVIDE ALLOWANCE TO REPLACE 10% OF THE (E) 1x WOOD STRIPING IN EACH LOCATION.
- 2 PROVIDE (N) CORD REEL MOUNTING BRACKETS - SEE DETAIL 18/AB.0.
- 3 PROVIDE NEW 1x WOOD STRIPING TO BOTTOM OF (E) ROOF FRAMING IN THIS AREA WHERE (E) HARD LID CEILING WAS REMOVED. HEIGHT AND CONFIGURATION TO MATCH (E) ADJACENT ROOM FOR NEW CONTINUOUS CEILING FINISH.
- 4 (E) ROOM RELIEF AIR VENT - REMOVE AND REINSTALL GRILL AS NEEDED TO ACCOMMODATE NEW CEILING TILES.
- 5 PATCH AND REPAIR (E) PLASTER CEILING AT ALL AREAS OF DEMOLITION AND NEW WORK/PREP AND PAINT.
- 6 (E) CEILING SUSPENDED EXPOSED DUCTWORK - REMOVE AND REINSTALL AS REQUIRED FOR NEW CEILING AND WALL WORK.
- 7 (E) WALL MOUNTED EXPOSED DUCTWORK - REMOVE AND REINSTALL WITH SUSPENDED MOUNTING - SEE MECHANICAL DRAWINGS.
- 8 NEW VENT OR FUME HOOD EXHAUST PENETRATION THROUGH (E) CEILING. PATCH AND REPAIR AS REQUIRED.
- 9 NEW CEILING FAN - SEE MECHANICAL.
- 10 EXHAUST AIR GRILL - SEE MECHANICAL.
- 11 SUPPLY AIR GRILL - SEE MECHANICAL.

GENERAL NOTES

- 1. CONTRACTOR SHALL REMOVE AND REINSTALL ALL CEILING MOUNTED EQUIPMENT AS REQUIRED TO REPLACE CEILING TILES. THIS INCLUDES ALL LIGHTING, SURFACE MOUNTED RACEWAY FOR FIRE ALARM AND VENTILATION SYSTEMS, CURTAIN CEILING TRACKS, ETC. WORK AROUND (E) SUSPENDED GAS PIPING.

KEYPLAN:

N.T.S.

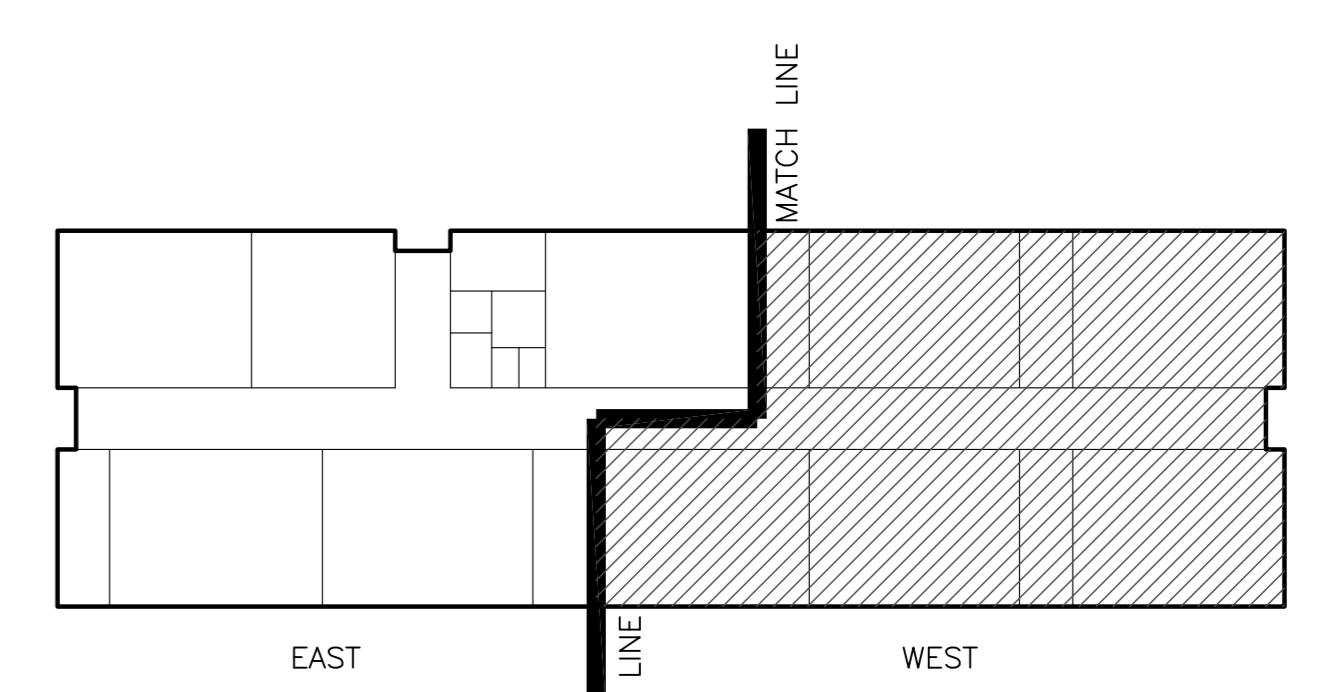

Mt. Diablo High School
Building S - Science Lab Modernization
2480 Grant Street
Concord, California 94520
Mt. Diablo Unified School District



FILE NO. XX-XX
 IDENTIFICATION STAMP
 DIV. OF THE STATE ARCHITECT
 OFFICE OF REGULATION SERVICES
 APPLICATION NO. 01-
 AC. FLS. SS.
 DATE

DIVISION OF THE STATE ARCHITECT
revision date: by:

CONSULTANT
nacht&lewis
600 Q Street, Suite 100
Sacramento, CA 95811
www.nachtandlewis.com
916.329.4000

ARCHITECT

REVISIONS		
NO.	DESCRIPTION	DATE / REV'D

DATE February 19, 2012

JOB NO. Y1211.00

SHEET TITLE
Partial Reflected Ceiling Plan West

SHEET NO.

A4.1

SHEET ___ OF ___ TOTAL
DSA SUBMITTAL SET

ONE INCH = TWENTY FEET
ONE-SIXTEENTH INCH = ONE FOOT
ONE-EIGHTH INCH = ONE FOOT
ONE-FOURTH INCH = ONE FOOT
ONE-HALF INCH = ONE FOOT
THREE-QUARTERS INCH = ONE FOOT
ONE INCH = ONE FOOT
ONE AND ONE-HALF INCH = ONE FOOT

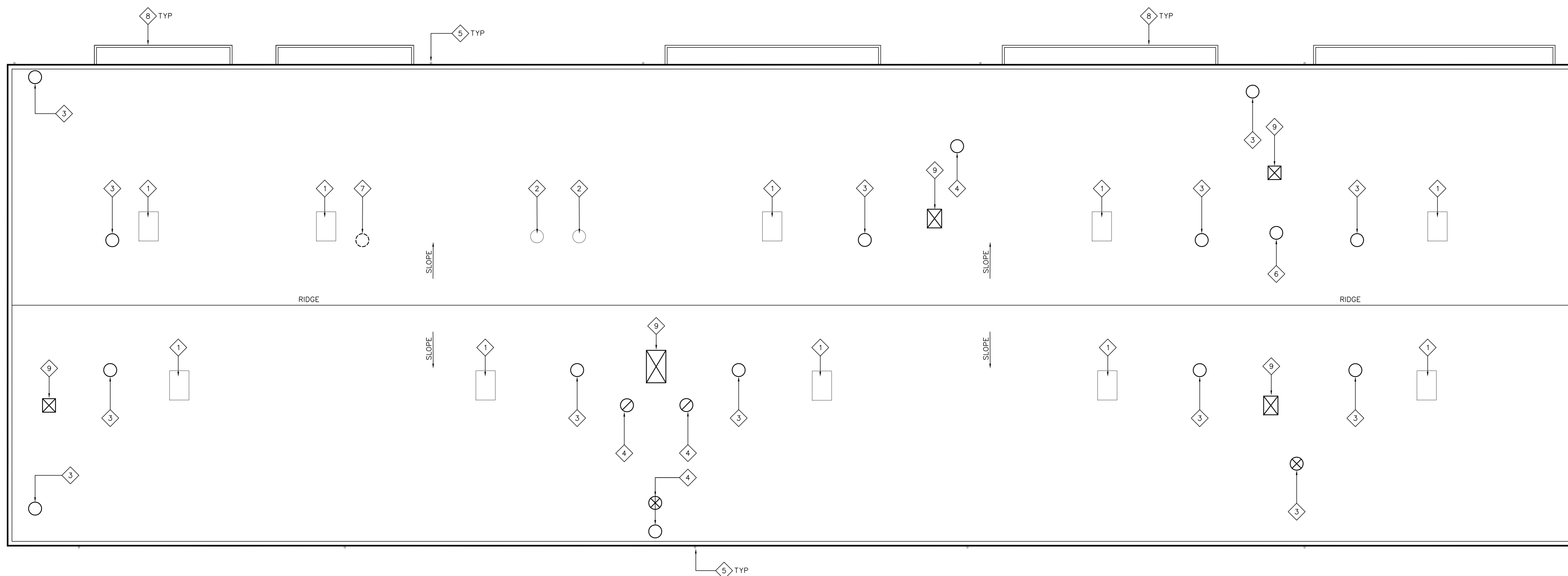

1 ROOF PLAN
SCALE: 1/8"=1'-0"

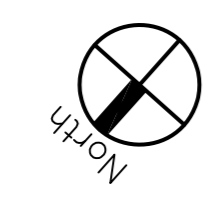

NEW WORK KEYNOTES:
THESE NEW WORK KEYNOTES APPLY TO THIS SHEET ONLY.

- ◇ EXISTING RELIEF AIR HOOD TO REMAIN □
- ◇ EXISTING ROOF EXHAUST FAN TO REMAIN ○
- ◇ NEW ROOF EXHAUST FAN AND CURB - INSTALL OVER EXISTING ROOF OPENING. ○
- ◇ NEW ROOF EXHAUST FAN AND CURB - INSTALL OVER NEW ROOF OPENING. ⊗
- ◇ EXISTING RAIN WATER LEADERS TO REMAIN
- ◇ NOT USED
- ◇ REMOVE EXISTING ROOF EXHAUST FAN; PATCH AND SEAL EXISTING OPENING. SEE DETAIL X/SX.X ○
- ◇ EXISTING LOWER ROOF OVERHANG AT SUNSHADES TO REMAIN.
- ◇ NEW ROOF INTAKE HOOD AND CURB - INSTALL OVER NEW OPENING ⊗

GENERAL NOTES

1. PROVIDE WATER-TIGHT PATCH AND REPAIR OF EXISTING 5-PLY BUILT-UP ROOF AT ALL ROOF PENETRATION AREAS.
2. SEE MECHANICAL AND STRUCTURAL DRAWINGS FOR ROOF OPENINGS AND CURB CONDITIONS.

Mt. Diablo High School
Building S - Science Lab Modernization

2450 Grant Street
 Concord, California 94520

Mt. Diablo Unified School District



FILE NO. XX-XX
 IDENTIFICATION STAMP
 DIV. OF THE STATE ARCHITECT
 OFFICE OF REGULATION SERVICES
 APPLICATION NO. 01-
 AC. FLS. SS
 DATE

DIVISION OF THE STATE ARCHITECT
 revision date: by:

CONSULTANT

nacht&lewis
 600 Q Street, Suite 100
 Sacramento, CA 95811
 www.nachtlewis.com
 916.329.4000

ARCHITECT

REVISIONS

NO.	DESCRIPTION	DATE	REV'D

DATE February 19, 2012
 JOB NO. Y1211.00
 SHEET TITLE

Roof Plan

SHEET NO. **A5.0**
 SHEET ___ OF ___ TOTAL
 DSA SUBMITTAL SET

ONE AND ONE-HALF INCH = ONE FOOT
ONE INCH = ONE FOOT
THREE-QUARTERS INCH = ONE FOOT
ONE-HALF INCH = ONE FOOT
ONE-QUARTER INCH = ONE FOOT
ONE-EIGHTH INCH = ONE FOOT
ONE-SIXTEENTH INCH = ONE FOOT
ONE INCH = TWENTY FEET

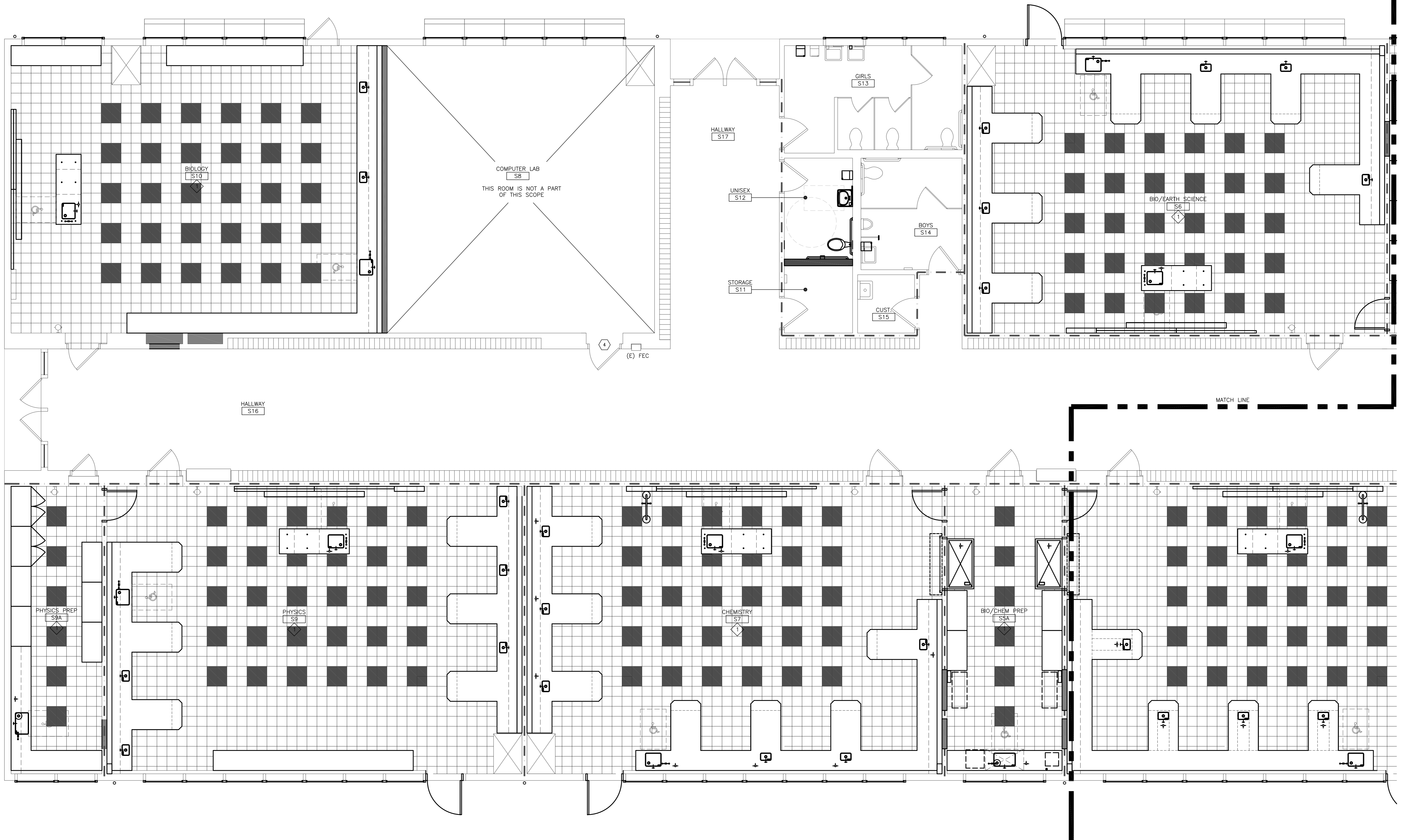

1 Partial Floor Finish Marking Plan - East
SCALE: 1/4"=1'-0"

FLOOR FINISH KEYNOTES:
THESE KEYNOTES APPLY TO THIS SHEET ONLY

- 1 REMOVE EXISTING VCT/VAT FLOORING AND RESILIENT BASE AND REPLACE WITH NEW BBT FLOORING AND RESILIENT BASE.

GENERAL NOTES

1. EXTEND NEW FLOORING AND RESILIENT BASE UNDER ALL EXPOSED AND SEMI-EXPOSED CABINET AREAS, RECESSES, AND ACCESSIBLE SINK CABINET SPACES.
2. CONTRACTOR TO PROVIDE SIMILAR BBT PATTERN TO ONE SHOWN. COORDINATE FINAL DESIGN DURING SUBMITTAL PROCESS.

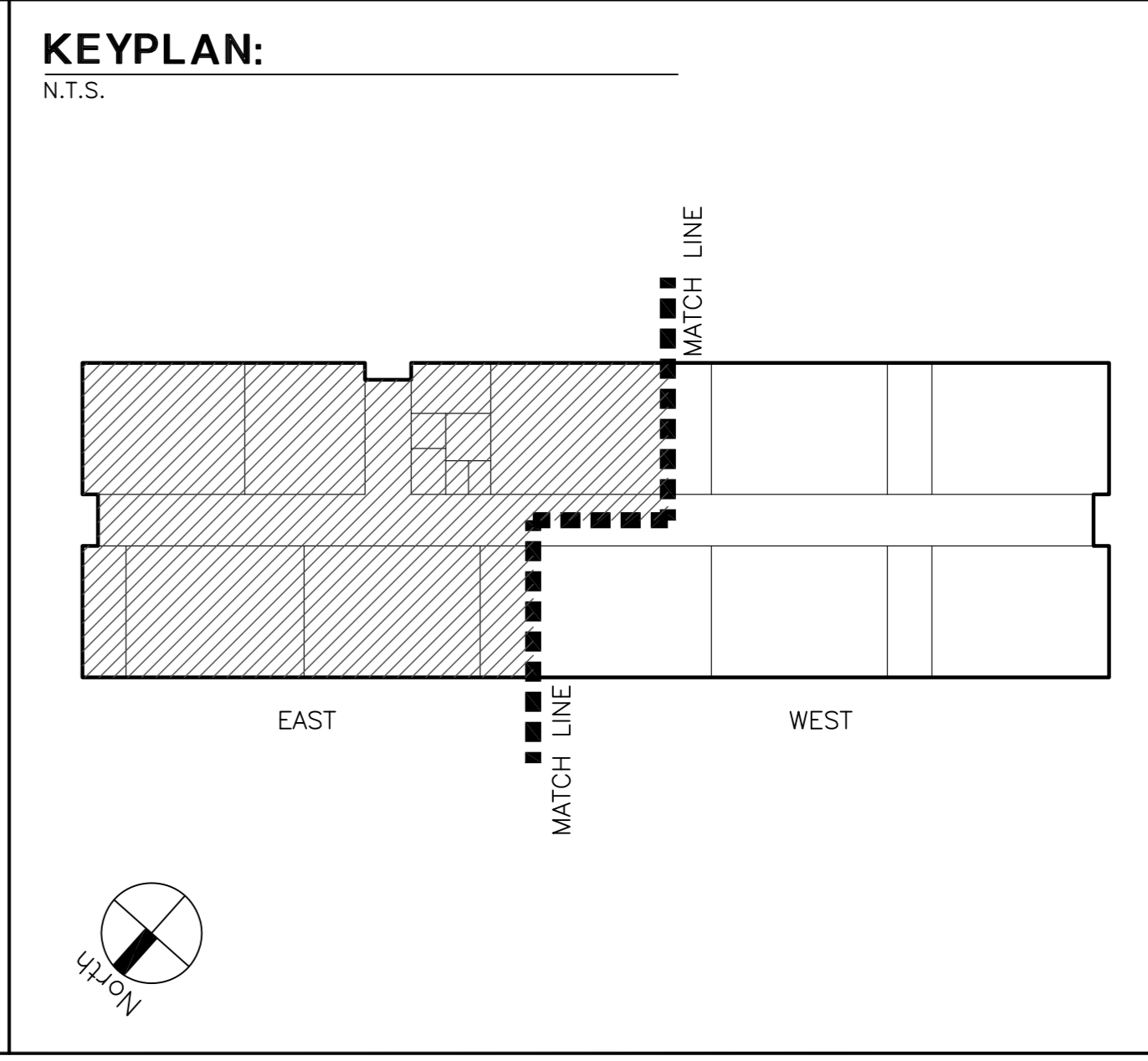

Mt. Diablo High School
Building S - Science Lab Modernization
2440 Grant Street
Concord, California 94520
Mt. Diablo Unified School District



FILE NO. XX-XX
IDENTIFICATION STAMP
DIV. OF THE STATE ARCHITECT
OFFICE OF REGULATION SERVICES
APPLICATION NO. 01-
AC. FLS. SS
DATE

DIVISION OF THE STATE ARCHITECT
revision date: by:

CONSULTANT
nacht&lewis
600 O Street, Suite 100
Sacramento, CA 95811
www.nachtandlewis.com
916.329.4000

ARCHITECT

NO.	DESCRIPTION	DATE	REV

DATE February 19, 2012
JOB NO. Y1211.00
SHEET TITLE
Partial Floor Finish Marking Plan East
SHEET NO.
A6.0
SHEET ___ OF TOTAL
DSA SUBMITTAL SET

ONE AND ONE-HALF INCH = ONE FOOT
ONE INCH = ONE FOOT
THREE-QUARTERS INCH = ONE FOOT
ONE-HALF INCH = ONE FOOT
ONE-QUARTER INCH = ONE FOOT
ONE-EIGHTH INCH = ONE FOOT
ONE-SIXTEENTH INCH = ONE FOOT
ONE INCH = TWENTY FEET

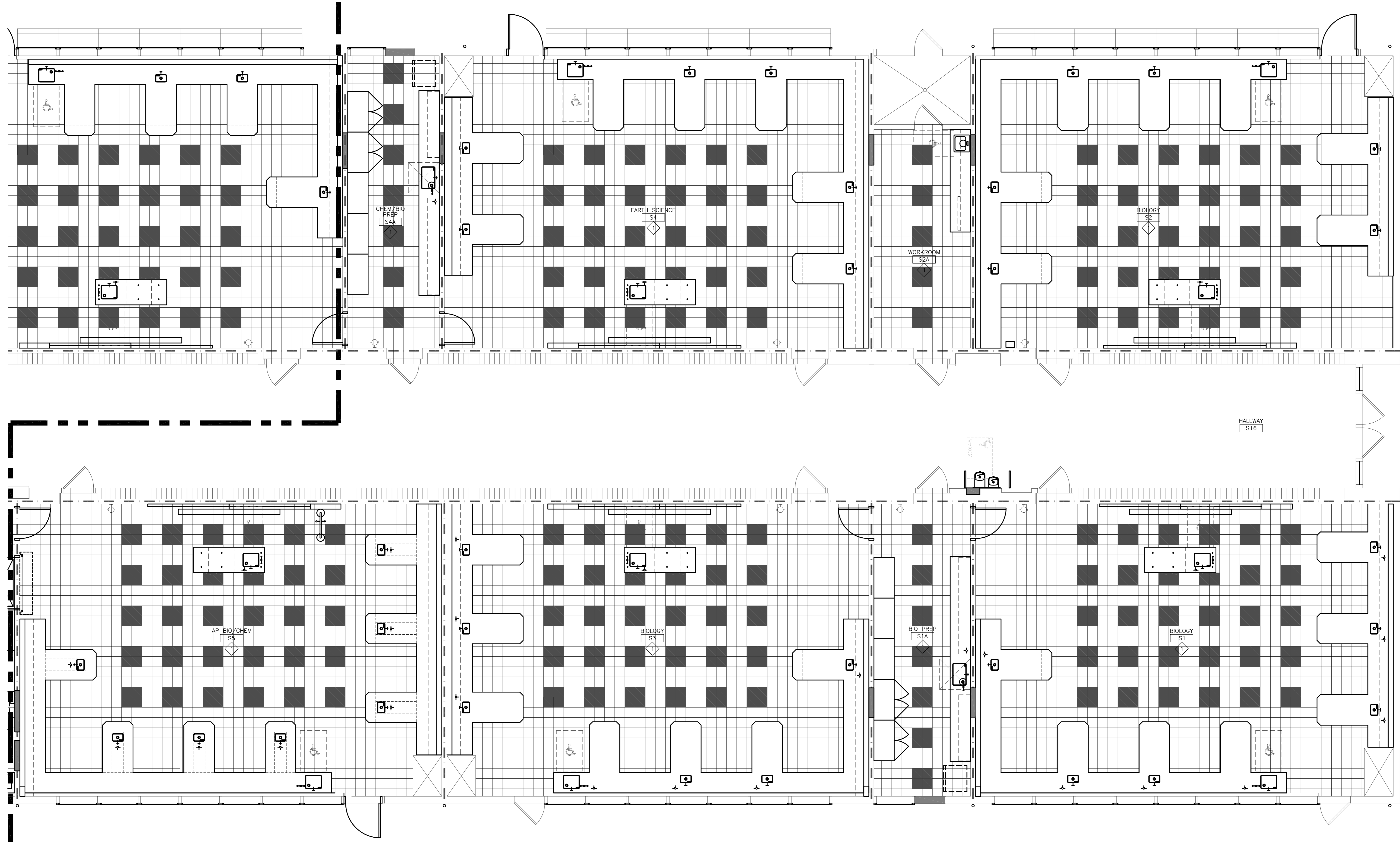

1 Partial Floor Finish Marking Plan - West
SCALE: 1/4"=1'-0"

FLOOR FINISH KEYNOTES:

THESE KEYNOTES APPLY TO THIS SHEET ONLY
1 REMOVE EXISTING VCT/VAT FLOORING AND RESILIENT BASE AND REPLACE WITH NEW BBT FLOORING AND RESILIENT BASE.

GENERAL NOTES

- 1. EXTEND NEW FLOORING AND RESILIENT BASE UNDER ALL EXPOSED AND SEMI-EXPOSED CABINET AREAS, RECESSES, AND ACCESSIBLE SINK CABINET SPACES.
- 2. CONTRACTOR TO PROVIDE SIMILAR BBT PATTERN TO ONE SHOWN. COORDINATE FINAL DESIGN DURING SUBMITTAL PROCESS.

KEYPLAN:

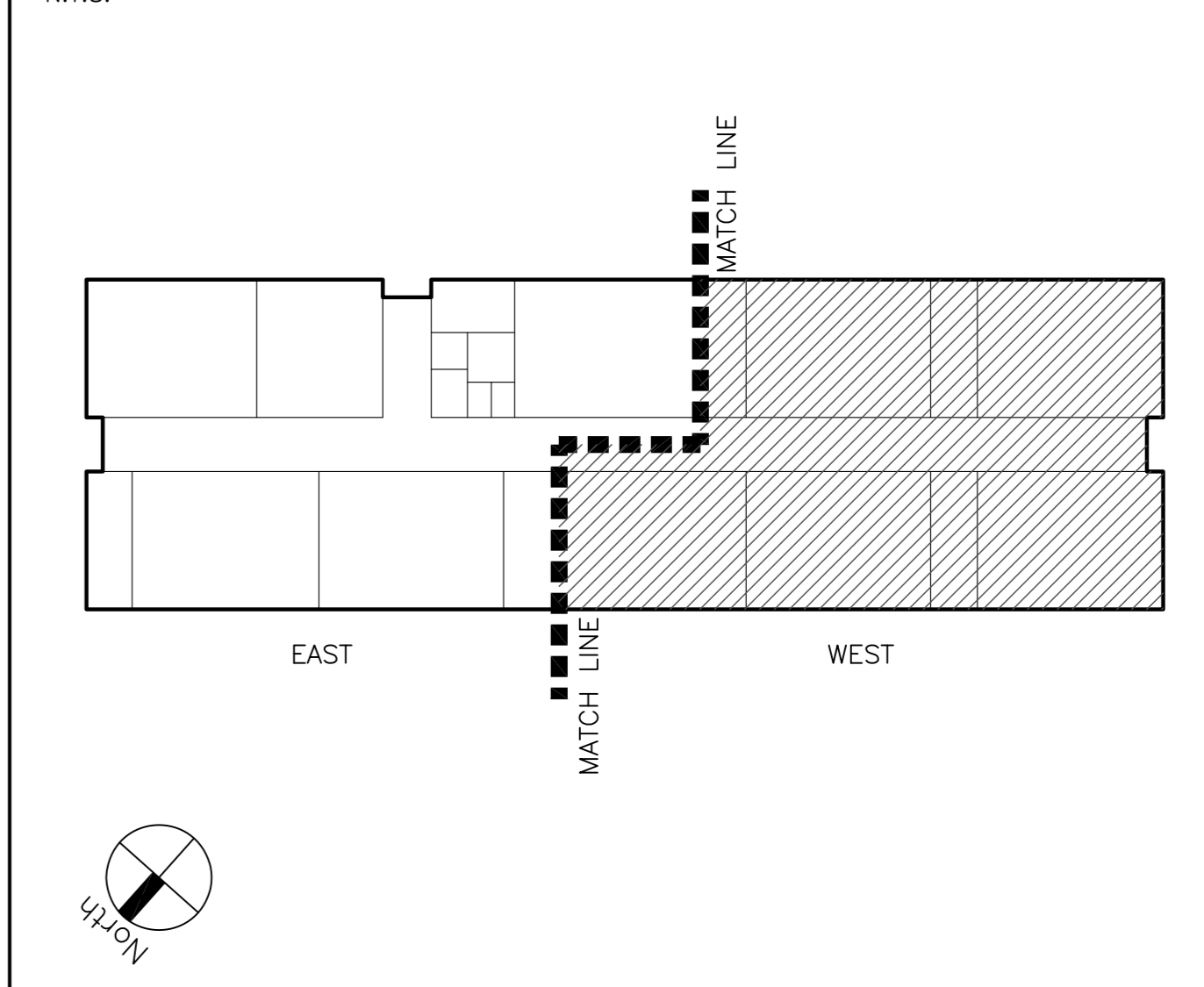

Mt. Diablo High School
Building S - Science Lab Modernization
2460 Grant Street
Concord, California 94520
Mt. Diablo Unified School District



FILE NO. XX-XX
IDENTIFICATION STAMP
DIV. OF THE STATE ARCHITECT
OFFICE OF REGULATION SERVICES
APPLICATION NO. 01-
AC. FLS. SS
DATE

DIVISION OF THE STATE ARCHITECT
revision date: by:

CONSULTANT
nacht&lewis
600 Q Street, Suite 100
Sacramento, CA 95811
www.nachtandlewis.com
916.329.4000

ARCHITECT

NO.	DESCRIPTION	DATE	REV

DATE February 19, 2012
JOB NO. Y1211.00
SHEET TITLE
Partial Floor Finish Marking Plan West
SHEET NO.
A6.1
SHEET ___ OF TOTAL
DSA SUBMITTAL SET

OPENING SCHEDULE

DOOR NO.	NOMINAL DOOR SIZE (W x H) (INSIDE OF FRAME)	DOOR		HARDWARE GROUP	GLASS	ASSEMBLY RATING	FRAME		DETAILS			REMARK NOTES - SEE BELOW		
		TYPE	MAT.				MAT.	FIN.	HEAD	JAMB	JAMB		SILL	
1	PR. 3'-0" x 7'-0"	C	FRP	F5	(E) PANIC	(N)	(E)HM16	F3-ALT	---	---	---	S4, S6, S8, R2, R4		
2	3'-0" x 7'-0"	A	WD	F2	01	(E)	60 MIN (E)HM16	F3	---	---	---	S5, S9, R1, R5, R7		
3	3'-0" x 7'-0"	A	WD	F3	04	(E)	---	(E)HM16	F3	---	---	S8, R1		
4	3'-0" x 7'-0"	A	WD	F2	(E) PANIC	(N)	60 MIN (E)HM16	F3	---	---	---	R5, R7		
5	PR. 3'-0" x 7'-0"	C	FRP	F5	(E) PANIC	(N)	---	(E)HM16	F3-ALT	---	---	S4, S6, S8, R2, R4		
6	3'-0" x 7'-0"	A	WD	F2	(E) LEVER	---	60 MIN (E)HM16	F3	---	---	---	S1A		
7	3'-0" x 7'-0"	A	WD	F2	(E) LEVER	---	60 MIN (E)HM16	F3	---	---	---	S3		
8	3'-0" x 7'-0"	A	WD	F2	(E) LEVER	---	60 MIN (E)HM16	F3	---	---	---	S5		
9	3'-0" x 7'-0"	A	WD	F2	(E) LEVER	---	60 MIN (E)HM16	F3	---	---	---	S5		
10	3'-0" x 7'-0"	A	WD	F2	(E) LEVER	---	60 MIN (E)HM16	F3	---	---	---	S2A		
11	(N) 3'-5" x 7'-0"	B	HM16	F1	04	---	---	(N)HM16	F1	15/AB.1	20/AB.1	20/AB.1	25/AB.1	S8, R8
12	3'-0" x 7'-0"	A	WD	F2	03	(E)	60 MIN (E)HM16	F3	---	---	---	---	S5, S9, R3, R5, R7, V1	
13	2'-4" x 7'-0"	A	WD	F2	02	(E)	60 MIN (E)HM16	F3	---	---	---	---	R5, R7	
14	(N) 3'-0" x 7'-0"	B	WD	F1	02	---	60 MIN (N)HM16	F1	22/AB.1	21/AB.1	21/AB.1	N/A	S5, S9	
15	3'-0" x 7'-0"	A	WD	F2	03	(E)	60 MIN (E)HM16	F3	---	---	---	---	S5, S9, R3, R5, R7	
16	(N) 3'-5" x 7'-0"	B	HM16	F1	04	---	---	(N)HM16	F1	15/AB.1	20/AB.1	20/AB.1	25/AB.1	S8, R8
17	(N) 3'-5" x 7'-0"	B	HM16	F1	04	---	---	(N)HM16	F1	15/AB.1	20/AB.1	20/AB.1	25/AB.1	S8, R8
18	3'-0" x 7'-0"	A	WD	F2	03	(E)	60 MIN (E)HM16	F3	---	---	---	---	S5, S9, R3, R5, R7	
19	3'-0" x 7'-0"	A	WD	F2	02	(E)	60 MIN (E)HM16	F3	---	---	---	---	R5, R7	
20	(N) 3'-0" x 7'-0"	B	WD	F1	02	---	60 MIN (N)HM16	F1	22/AB.1	21/AB.1	21/AB.1	N/A	S5, S9	
21	(N) 3'-0" x 7'-0"	B	WD	F1	02	---	60 MIN (N)HM16	F1	22/AB.1	21/AB.1	21/AB.1	N/A	S5, S9	
22	3'-0" x 7'-0"	A	WD	F2	03	(E)	60 MIN (E)HM16	F3	---	---	---	---	S5, S9, R3, R5, R7	
23	(N) 3'-5" x 7'-0"	B	HM16	F1	04	---	---	(N)HM16	F1	22/AB.1	21/AB.1	21/AB.1	N/A	S8, R8
24	3'-0" x 7'-0"	A	WD	F3	04	(E)	---	(E)HM16	F3	---	---	---	---	S8, R1
25	3'-0" x 7'-0"	A	WD	F2	01	(E)	60 MIN (E)HM16	F3	---	---	---	---	S5, S9, R1, R5, R7	
26	3'-0" x 7'-0"	A	WD	F2	02	(E)	60 MIN (E)HM16	F3	---	---	---	---	R5, R7	
27	(N) 3'-0" x 7'-0"	B	WD	F1	02	---	60 MIN (N)HM16	F1	22/AB.1	21/AB.1	21/AB.1	N/A	S5, S9	
28	(N) 3'-0" x 7'-0"	B	WD	F1	02	---	60 MIN (N)HM16	F1	22/AB.1	21/AB.1	21/AB.1	N/A	S5, S9	
29	3'-0" x 7'-0"	A	WD	F2	01	(E)	60 MIN (E)HM16	F3	---	---	---	---	S5, S9, R1, R5, R7	
30	3'-0" x 7'-0"	A	WD	F3	04	(E)	---	(E)HM16	F3	---	---	---	S8, R1	
31	PR. 3'-0" x 7'-0"	C	FRP	F5	(E) PANIC	(N)	---	(E)HM16	F3-ALT	---	---	---	S4, S6, S8, R2, R4	
32	(N) 3'-5" x 7'-0"	B	HM16	F1	04	---	---	(N)HM16	F1	15/AB.1	20/AB.1	20/AB.1	25/AB.1	S8, R8
33	3'-0" x 7'-0"	A	WD	F2	01	(E)	60 MIN (E)HM16	F3	---	---	---	---	S5, S9, R1, R5, R7	
34	3'-0" x 7'-0"	A	WD	F2	02	(E)	60 MIN (E)HM16	F3	---	---	---	---	S5, S9, R5, R7	
35	2'-9" x 7'-0"	A	WD	F2	05	(E)	---	(E)HM16	F3	---	---	---	---	---
36	2'-9" x 7'-0"	A	WD	F3	06	(E)	---	(E)HM16	F3	---	---	---	---	---
37	3'-0" x 7'-0"	A	WD	F2	01	(E)	60 MIN (E)HM16	F3	---	---	---	---	S5, S9, R1, R5, R7	
38	(N) 3'-5" x 7'-0"	B	HM16	F1	04	---	---	(N)HM16	F1	15/AB.1	20/AB.1	20/AB.1	25/AB.1	S8, R8
39	(N) 3'-0" x 7'-0"	B	WD	F2	02	---	60 MIN (N)HM16	F1	22/AB.1	21/AB.1	21/AB.1	N/A	S5, S9	
40	3'-0" x 7'-0"	A	WD	F2	02	(E)	60 MIN (E)HM16	F3	---	---	---	---	R5, R7	
41	(N) 3'-0" x 7'-0"	B	WD	F2	02	---	60 MIN (N)HM16	F1	22/AB.1	21/AB.1	21/AB.1	N/A	S5, S9	
42	(N) 5'-6" x 7'-6"	D	---	F5	(N)	---	60 MIN (N)HM16	F5	30/AB.1	27/AB.1	27/AB.1	26/AB.1	R6, OVERHEAD COILING FIRE DOOR	
43	(N) 5'-6" x 7'-6"	D	---	F5	(N)	---	60 MIN (N)HM16	F5	30/AB.1	27/AB.1	27/AB.1	26/AB.1	R6, OVERHEAD COILING FIRE DOOR	

DOOR & FRAME MATERIALS		OPENING REMARK NOTES		OPENING TYPES	
HM16 HOLLOW METAL 16 GA. WOOD WD ALU ALUMINUM FRP FIBERGLASS REINFORCED PLASTIC CL CHAIN LINK FENCING	S1. PROVIDE ACCESSIBLE "WOMEN" TOILET RM. SIGNAGE - SEE DETAIL 6/A6.3 (SIGN TYPE S1) S1A. PROVIDE ACCESSIBLE "GIRLS" TOILET RM. SIGNAGE - SEE DETAIL 6/A6.3 (SIGN TYPE S1A) S2. PROVIDE ACCESSIBLE "MEN" TOILET RM. SIGNAGE - SEE DETAIL 6/A6.3 (SIGN TYPE S2) S2A. PROVIDE ACCESSIBLE "BOYS" TOILET RM. SIGNAGE - SEE DETAIL 6/A6.3 (SIGN TYPE S2A) S3. PROVIDE ACCESSIBLE "UNISEX" TOILET RM. SIGNAGE - SEE DETAIL 6/A6.3 (SIGN TYPE S3) S4. PROVIDE ACCESSIBLE ENTRANCE SIGNAGE - SEE DETAIL 3/A6.3 (SIGN TYPE S4) S5. PROVIDE ROOM IDENTIFICATION SIGN - SEE DETAIL 13/A6.3 (SIGN TYPE S5) S6. PROVIDE MAIN ENTRANCE IDENTIFICATION SIGN - SEE DETAIL 13/A6.3 (SIGN TYPE S6) S8. PROVIDE EXIT SIGN - SEE DETAIL 4/A6.3 (SIGN TYPE S8) S9. PROVIDE EXIT ROUTE SIGN - SEE DETAIL 5/A6.3 (SIGN TYPE S9) V1. PROVIDE 8"W x 12"H VISION PANEL. R1. REMOVE (E) HARDWARE, PROVIDE DOOR SADDLE PER DETAIL 28/AB.0, AND INSTALL (N) HARDWARE. R2. REMOVE (E) 1/4" GLAZING AND REPLACE WITH (N) 1/4" CLEAR TEMPERED GLAZING. R3. (E) PANIC HARDWARE TO REMAIN. REMOVE AND REINSTALL AFTER DOOR PAINTING. R4. PROVIDE PAINTING OF FRAME AS PART OF ALTERNATE No. 1. R5. PAINT (E) VISION LITES IN DOORS. COLOR SHALL BE DIFFERENT FROM DOOR COLOR. R6. CONNECT TO FIRE ALARM SYSTEM. R7. PREPARE AND PAINT (E) WOOD DOOR. PATCH AND REPAIR (E) DAMAGE AND ANY ABANDONED HARDWARE PREPS. R8. NEW DOOR FRAMES SHALL MOUNT BETWEEN (E) 3X POSTS. CONTRACTOR TO FIELD VERIFY ACTUAL DOOR SIZE.	 			
FINISH		OPENING GENERAL NOTES			
F1 NEW PAINT - SEE SPECIFICATIONS F2 PAINT EXISTING STAINED SURFACE F3 PAINT EXISTING PAINTED SURFACE F4 RESTAIN/RESEAL EXISTING F5 FACTORY FINISH	1. EXIT AND EXIT-ACCESS DOORS LEADING FROM ROOMS HAVING AN OCCUPANT LOAD OF (50) OR MORE AND FROM CORRIDORS SHALL NOT BE PROVIDED WITH A LATCH OR LOCK UNLESS IT IS PANIC HARDWARE (CBC, SECTION 1007.3.10). 2. FIRE-RATED DOOR FRAMES SHALL BE INSTALLED IN ACCORDANCE WITH THE MANUFACTURER'S WRITTEN INSTRUCTIONS. MANUFACTURER'S INSTRUCTIONS SHALL BE MADE AVAILABLE TO THE DSA AND THE INSPECTOR OF RECORD. 3. ALL EXTERIOR GLAZING TO BE TINTED UNLESS OTHERWISE NOTED - SEE GLAZING SPECIFICATION SECTION 08 51 13. 4. SEE SPECIFICATIONS FOR HARDWARE GROUPS, MATERIALS AND FINISHES NOT IDENTIFIED HEREIN. 5. REMOVE ALL EXISTING SIGNAGE PRIOR TO NEW SIGNAGE INSTALL. AT ALL LOCATIONS WHERE EXISTING SIGNAGE IS REMOVED FROM WALLS, WALLS SHALL BE PATCHED, REPAIRED, AND PAINTED. AT CERAMIC TILE LOCATIONS, FILL HOLES WITH COLORED SEALANT TO MATCH.				

EXTERIOR GATE SCHEDULE

GATE NO.	NOMINAL GATE SIZE (W x H) (INSIDE OF FRAME)	GATE		HARDWARE GROUP	GLASS	ASSEMBLY RATING	FRAME		DETAILS			REMARK NOTES - SEE BELOW
		TYPE	MAT.				MAT.	FIN.	HEAD	JAMB	JAMB	
G1	(N) 3'-6" x 6'-0"	F	CL	F5	07	---	(N)CL	F5	---	17/A1.3	17/A1.3	---
G2	(N) 3'-6" x 6'-0"	F	CL	F5	08	---	(N)CL	F5	---	16/A1.3	16/A1.3	---
G3	(N) 3'-6" x 6'-0"	F	CL	F5	07	---	(N)CL	F5	---	17/A1.3	17/A1.3	---
G4	(N) 3'-6" x 6'-0"	F	CL	F5	07	---	(N)CL	F5	---	17/A1.3	17/A1.3	---

REQ/REP.1617 Attachment D

ROOM FINISH SCHEDULE

ROOM NO.	ROOM NAME	FLOOR	BASE	WALLS				CEILING	CEILING HEIGHT	CASEWORK	REMARK NOTES - SEE BELOW
				NORTH	EAST	SOUTH	WEST				
S1	BIOLOGY	BBT-1/BBT-2	RB-1	PT-1	TB-1/PT-1	TB-1/PT-1	TB-1/PT-1	CT-1	VARIABLE	PL1/SS1	RR-1
S1A	BIO PREP.	BBT-1/BBT-2	RB-1	PT-1	PT-1	PT-1	PT-1	CP-1	VARIABLE	PL1/SS1	
S2	BIOLOGY	BBT-1/BBT-2	RB-1	TB-1/PT-1	TB-1/PT-1	PT-1	TB-1/PT-1	CT-1	VARIABLE	PL1/SS1	
S2A	WORKROOM	BBT-1/BBT-2	RB-1	PT-1	PT-1	PT-1	PT-1	CP-1	VARIABLE	PL1	
S3	BIOLOGY	BBT-1/BBT-2	RB-1	PT-1	TB-1/PT-1	TB-1/PT-1	TB-1/PT-1	CT-1	VARIABLE	PL1/SS1	
S4	EARTH SCIENCE	BBT-1/BBT-2	RB-1	TB-1/PT-1	TB-1/PT-1	PT-1	TB-1/PT-1	CT-1	VARIABLE	PL1/SS1	
S4A	CHEM/BIO PREP.	BBT-1/BBT-2	RB-1	PT-1	PT-1	PT-1	PT-1	CP-1	VARIABLE	PL1/SS1	
S5	AP BIO/CHEM	BBT-1/BBT-2	RB-1	PT-1	TB-1/PT-1	TB-1/PT-1	TB-1/PT-1	CT-1	VARIABLE	PL1/SS1	
S5A	BIO/CHEM PREP.	BBT-1/BBT-2	RB-1	PT-1	PT-1	PT-1	PT-1	CP-1	VARIABLE	PL1/SS1	
S6	BIO/EARTH SCIENCE	BBT-1/BBT-2	RB-1	TB-1/PT-1	TB-1/PT-1	PT-1	TB-1/PT-1	CT-1	VARIABLE	PL1/SS1	
S7	CHEMISTRY	BBT-1/BBT-2	RB-1	PT-1	TB-1/PT-1	TB-1/PT-1	TB-1/PT-1	CT-1	VARIABLE	PL1/SS1	
S8	COMPUTER LAB	---	---	---	---	---	---	---	---	---	---
S9	PHYSICS	BBT-1/BBT-2	RB-1	PT-1	TB-1/PT-1	TB-1/PT-1	TB-1/PT-1	CT-1	VARIABLE	PL1/SS1	
S9A	PHYSICS PREP.	BBT-1/BBT-2	RB-1	PT-1	PT-1	PT-1	PT-1	CP-1	VARIABLE	PL1/SS1	
S10	BIOLOGY	BBT-1/BBT-2	RB-1	TB-1/PT-1	TB-1/PT-1	PT-1	TB-1/PT-1	CT-1	VARIABLE	PL1/SS1	
S11	STORAGE	VCT-3	VCT-3	WC-1/PT-1	WC-1/PT-1	WC-1/PT-1	WC-1/PT-1	CP-1	---	---	RR-3
S12	UNISEX TOILET	VCT-3	VCT-3	WC-1/PT-1	WC-1/PT-1	WC-1/PT-1	WC-1/PT-1	CP-1	---	---	RR-3
S13	GIRL'S TOILET	---	---	---	---	---	---	---	---	---	---
S14	BOY'S TOILET	---	---	---	---	---	---	---	---	---	---
S15	CUSTODIAN	---	---	---	---	---	---	---	---	---	---
S16	HALLWAY	---	---	PT-1	PT-1	PT-1	PT-1	PT-1	9'-0"	---	RR-2
S17	HALLWAY	---	---	PT-1	PT-1	PT-1	PT-1	PT-1	9'-0"	---	RR-2

FLOORS	BASES	WALLS & FABRIC PANELS	CEILING	ROOM FINISH REMARK NOTES
BBT-1 BIOBASED TILE MANUFACTURER: ARMSTRONG STYLE: MIGRATIONS COLOR: XXX	RB-1 RUBBER BASE MANUFACTURER: BURKE INDUSTRIES STYLE: TYPE TS COLOR: XXX	PT-1 PAINT MANUFACTURER: BENJAMIN MOORE & CO. STYLE: INTERIOR SEMI GLOSS COLOR: XXX	CT-1 APPLIED ACOUSTICAL CEILING TILE MANUFACTURE: USG SIZE: 12 x 12 INCHES STYLE: MILLENNIA CLIMAPLUS TILE COLOR: XXX	RR-1 SEE INTERIOR ELEVATIONS FOR LOCATIONS OF TACKABLE WALLBOARD. RR-2 BIDDERS - BREAK OUT REPAINTING OF WALLS, TRIM AND CEILING IN HALLWAYS AS A BID ALTERNATE. RR-3 PROVIDE 6" INTEGRALLY COVERED BASE.
BBT-2 BIOBASED TILE MANUFACTURER: ARMSTRONG STYLE: MIGRATIONS COLOR: XXX		TB-1 TACKABLE WALLBOARD MANUFACTURER: CHATFIELD-CLARKE CO. STYLE: VINYL PATTERN: BURLAP COLOR: XXX	CP-1 CEILING PAINT MANUFACTURER: BENJAMIN MOORE & CO. STYLE: INTERIOR SEMI GLOSS COLOR: XXX	
VCT-3 VINYL SHEET MANUFACTURER: ARMSTRONG STYLE: MEDITECH COLOR: XXX		WC-1 FIBERGLASS REINFORCED PANEL MANUFACTURER: MARLITE STYLE: FR CLASS 1A PATTERN: PEBBLE COLOR: XXX		
CONC EXISTING EXPOSED CONCRETE, SWEEP & MOP CLEAN				

CASEWORK	GENERAL FINISH NOTES
PL-1 PLASTIC LAMINATE MANUFACTURER: WILSONART, FORMICA, NEVAMAR OR APP. EQ. COLOR: XXX	1. PATCH AND REPAIR ALL SURFACES AND SUBSTRATES DAMAGED BY THE EXECUTION OF THE NEW WORK, TO AN ACCEPTABLE FINISHED CONDITION MATCHING ADJACENT SURFACES. 2. CONTRACTOR SHALL COORDINATE WORK WITH ARCHITECTURAL, STRUCT., MECH. & ELECT. DRAWINGS. WHERE NEW EXPOSED SURFACE MOUNTED UTILITIES ARE PROVIDED, COORDINATE ROUTING TO BUNDLE/COMBINE PATHWAYS WHERE POSSIBLE.

ONE AND ONE-HALF INCH = ONE FOOT
ONE INCH = ONE FOOT
THREE-QUARTERS INCH = ONE FOOT
ONE-QUARTER INCH = ONE FOOT
ONE-HALF INCH = ONE FOOT
ONE-QUARTER INCH = ONE FOOT
ONE-EIGHTH INCH = ONE FOOT
ONE-SIXTEENTH INCH = ONE FOOT
ONE INCH = TWENTY FEET

Mt. Diablo High School
Building S - Science Lab Modernization

2460 Grant Street
Concord, California 94520

Mt. Diablo Unified School District

MDUSD

FILE NO. XX-XX
IDENTIFICATION STAMP
DIV. OF THE STATE ARCHITECT
OFFICE OF REGULATION SERVICES

APPLICATION NO. 01-
AC. FLS. SS.

DATE

DIVISION OF THE STATE ARCHITECT
revision date: _____ by: _____

6 NOT USED
SCALE: 6" = 1'-0"

2 NOT USED
SCALE: 6" = 1'-0"

5 NOT USED
SCALE: 6" = 1'-0"

1 NOT USED
SCALE: 6" = 1'-0"

CONSULTANT

nacht&lewis

600 Q Street, Suite 100
Sacramento, CA 95811
www.nachtlewis.com
916.329.4000

ARCHITECT

NO.	DESCRIPTION	DATE	REV'D

DATE February 19, 2012
JOB NO. Y1211.00
SHEET TITLE

Opening and Finish Schedule

SHEET NO.
A6.2
SHEET ____ OF TOTAL
DSA SUBMITTAL SET

ONE AND ONE-HALF INCH = ONE FOOT
 ONE INCH = ONE FOOT
 THREE-QUARTERS INCH = ONE FOOT
 ONE-HALF INCH = ONE FOOT
 ONE-QUARTER INCH = ONE FOOT
 ONE-EIGHTH INCH = ONE FOOT
 ONE-SIXTEENTH INCH = ONE FOOT
 ONE INCH = TWENTY FEET

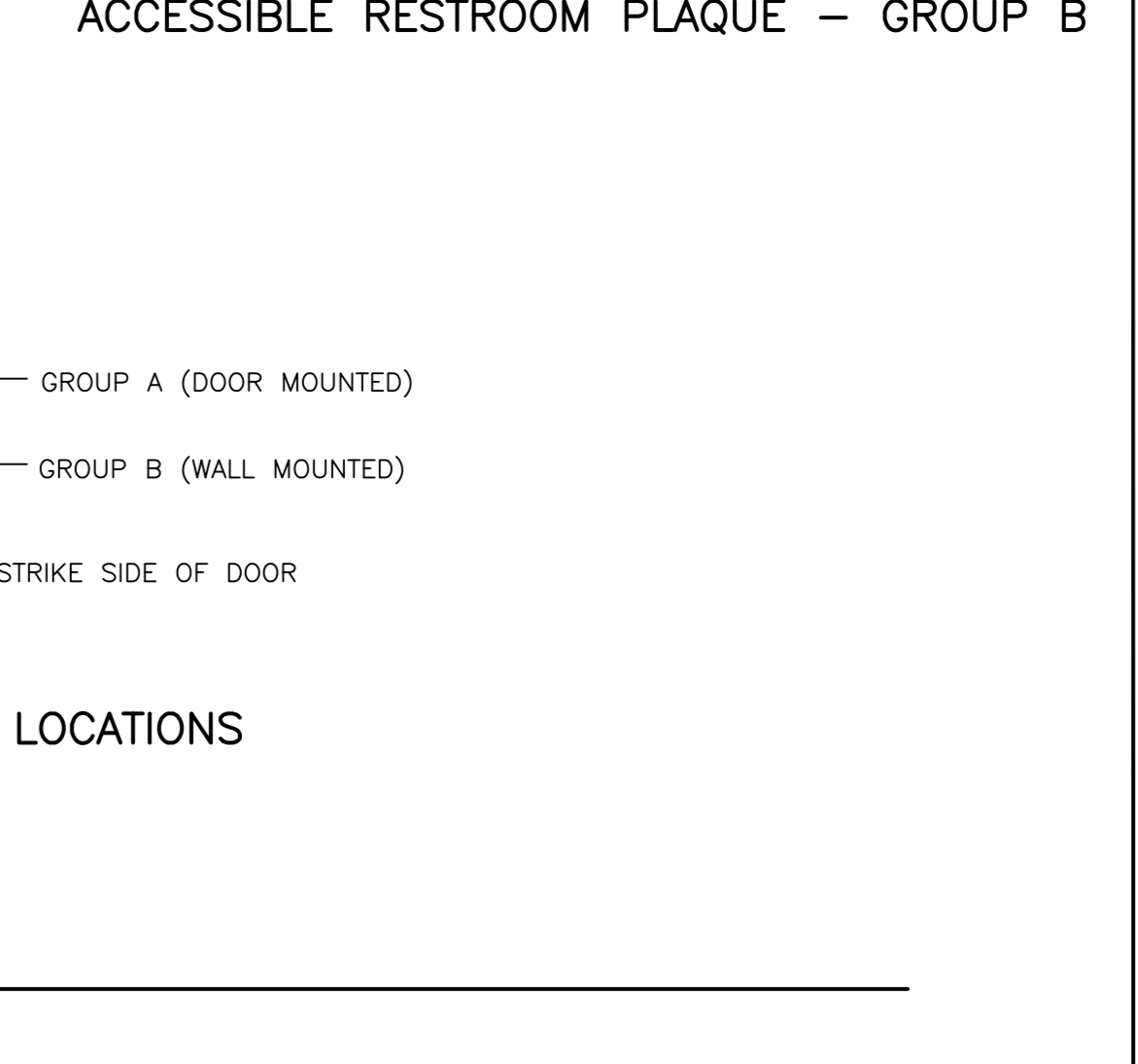
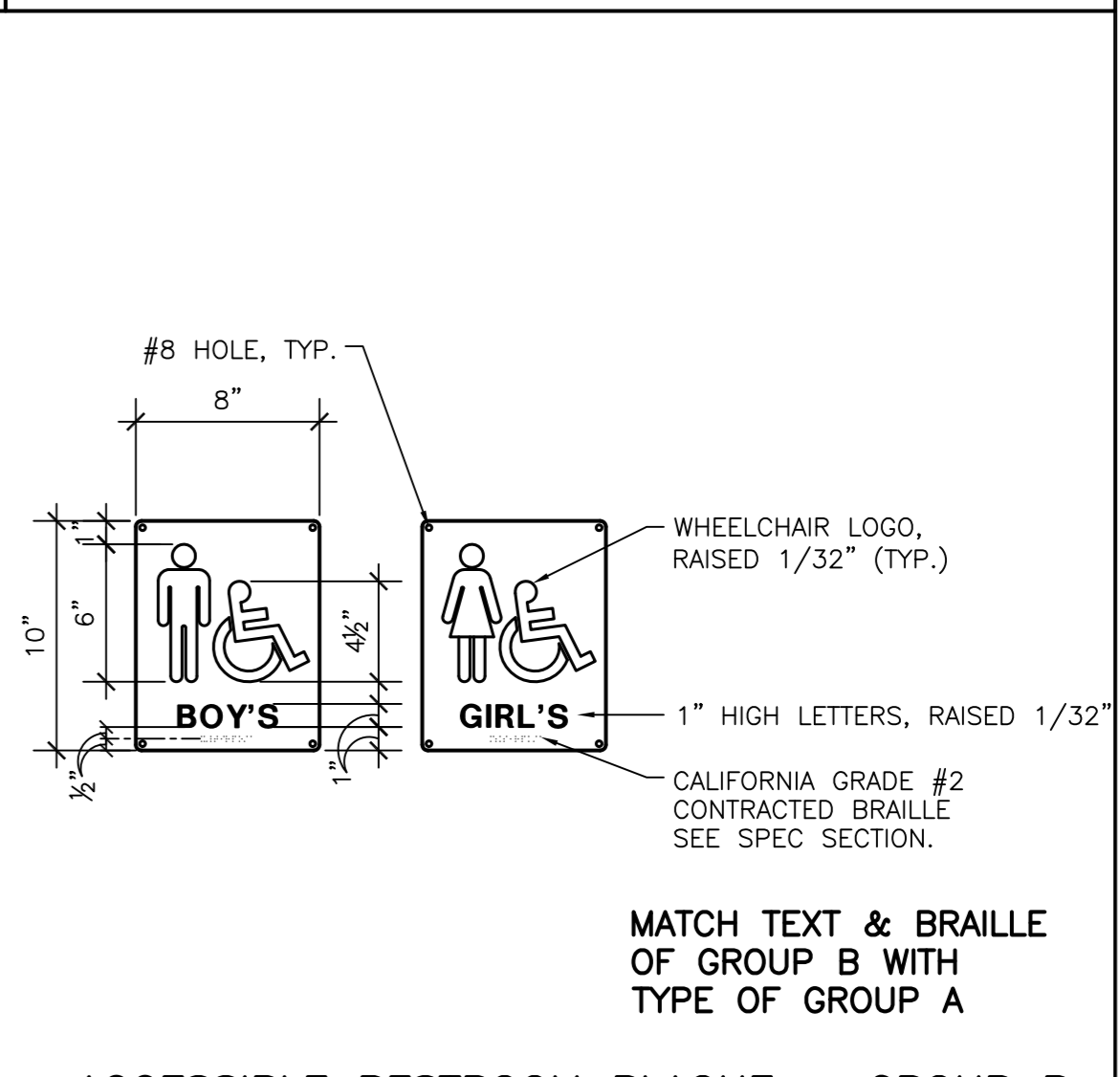
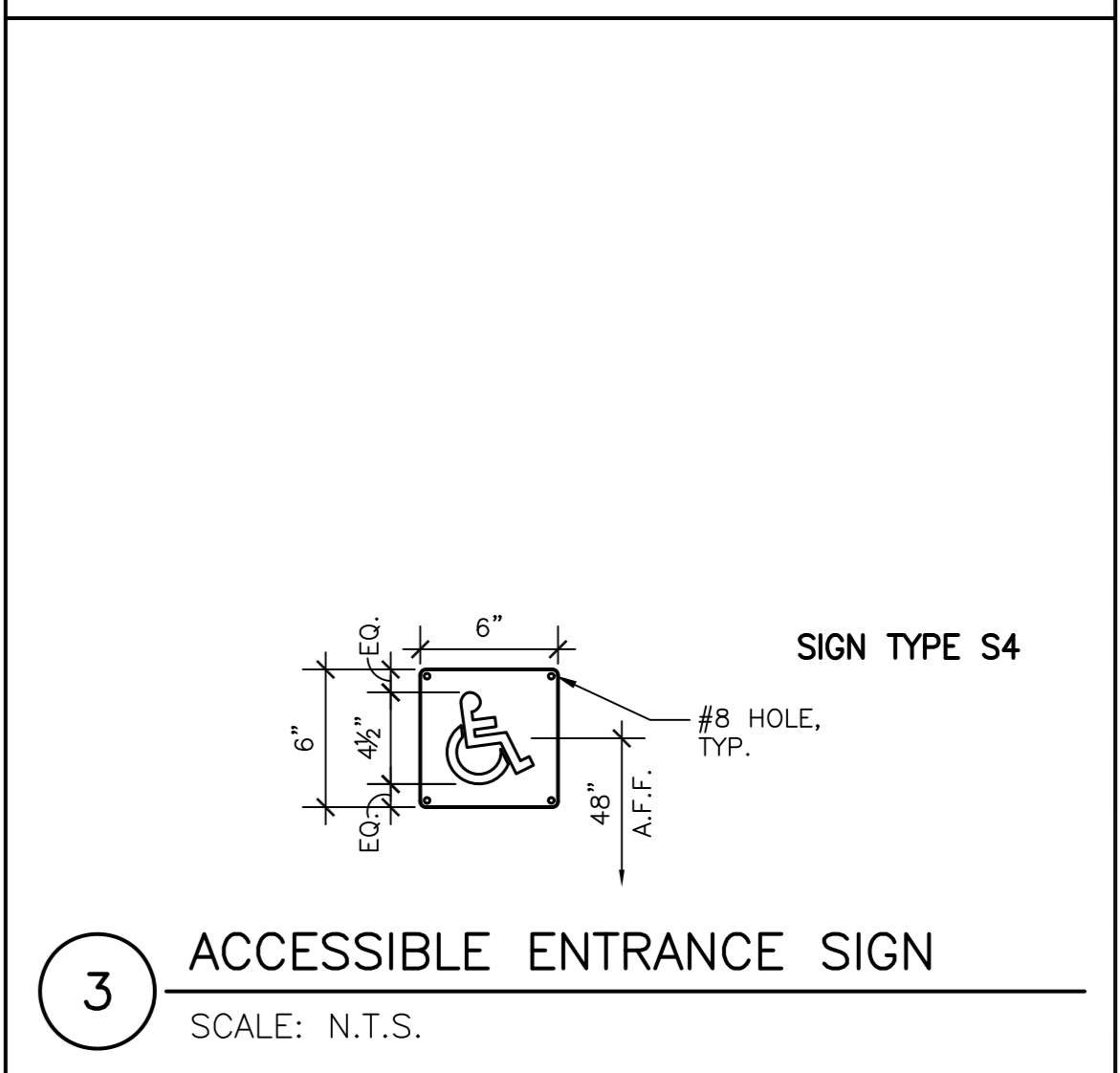
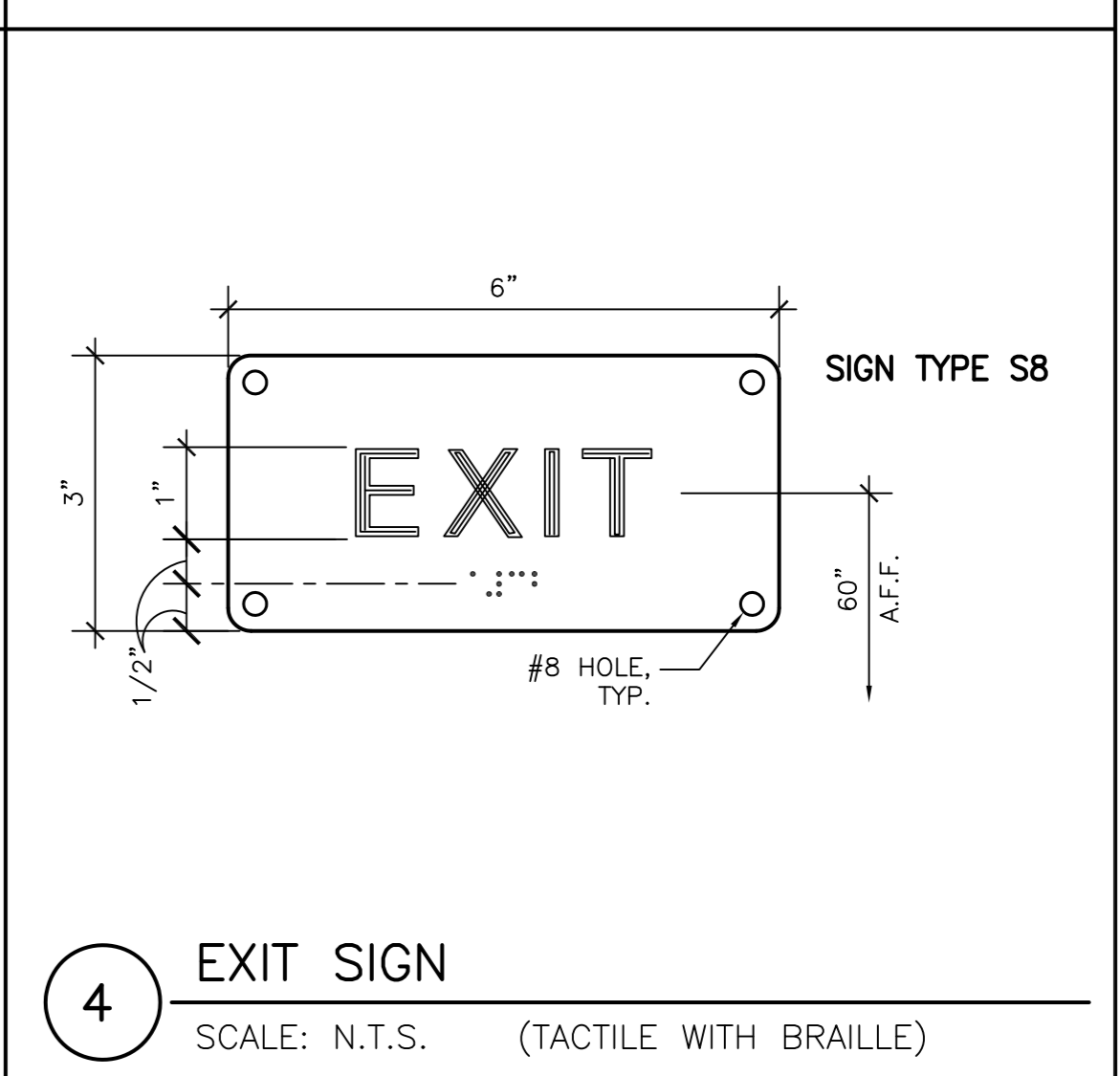
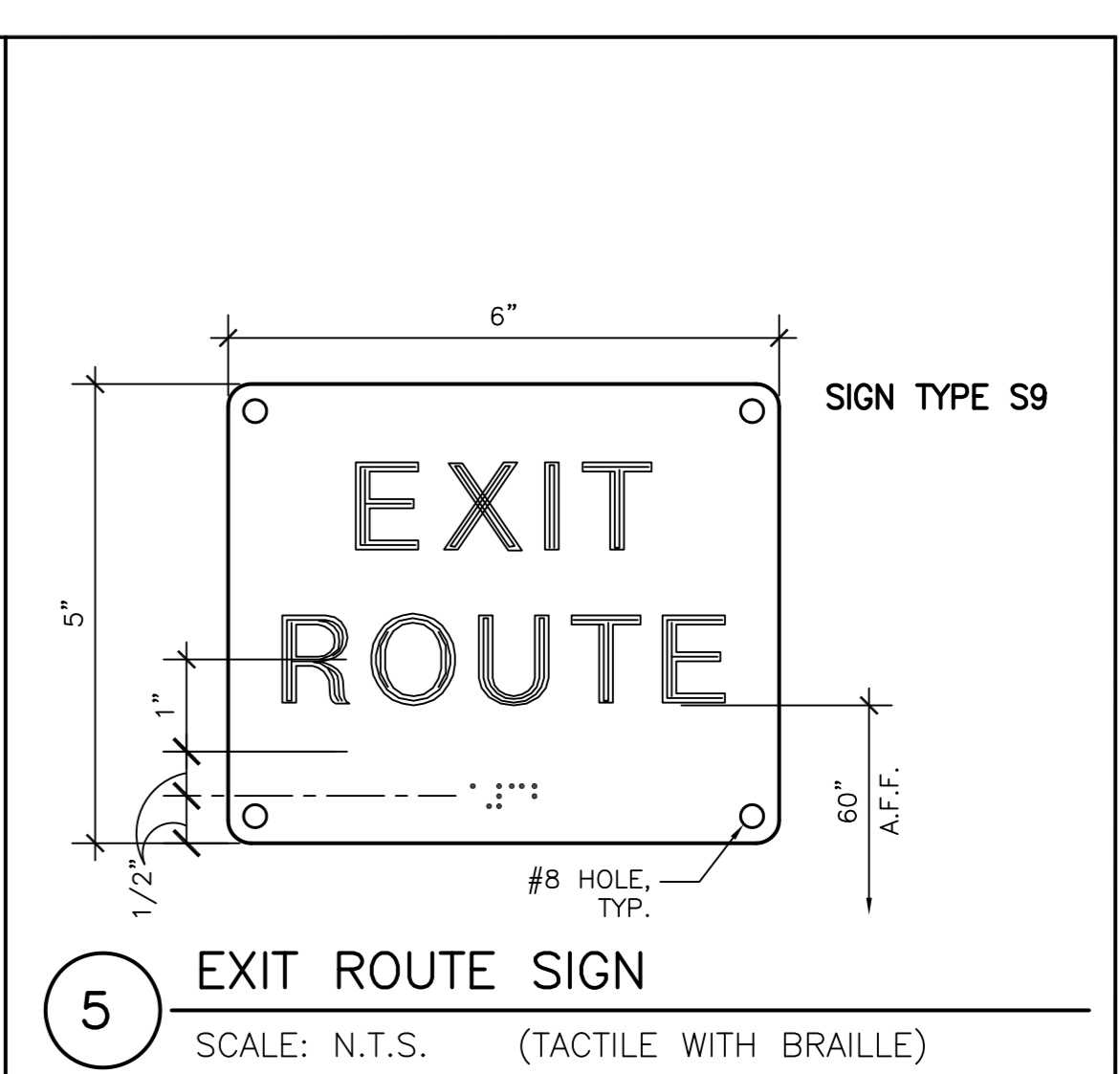
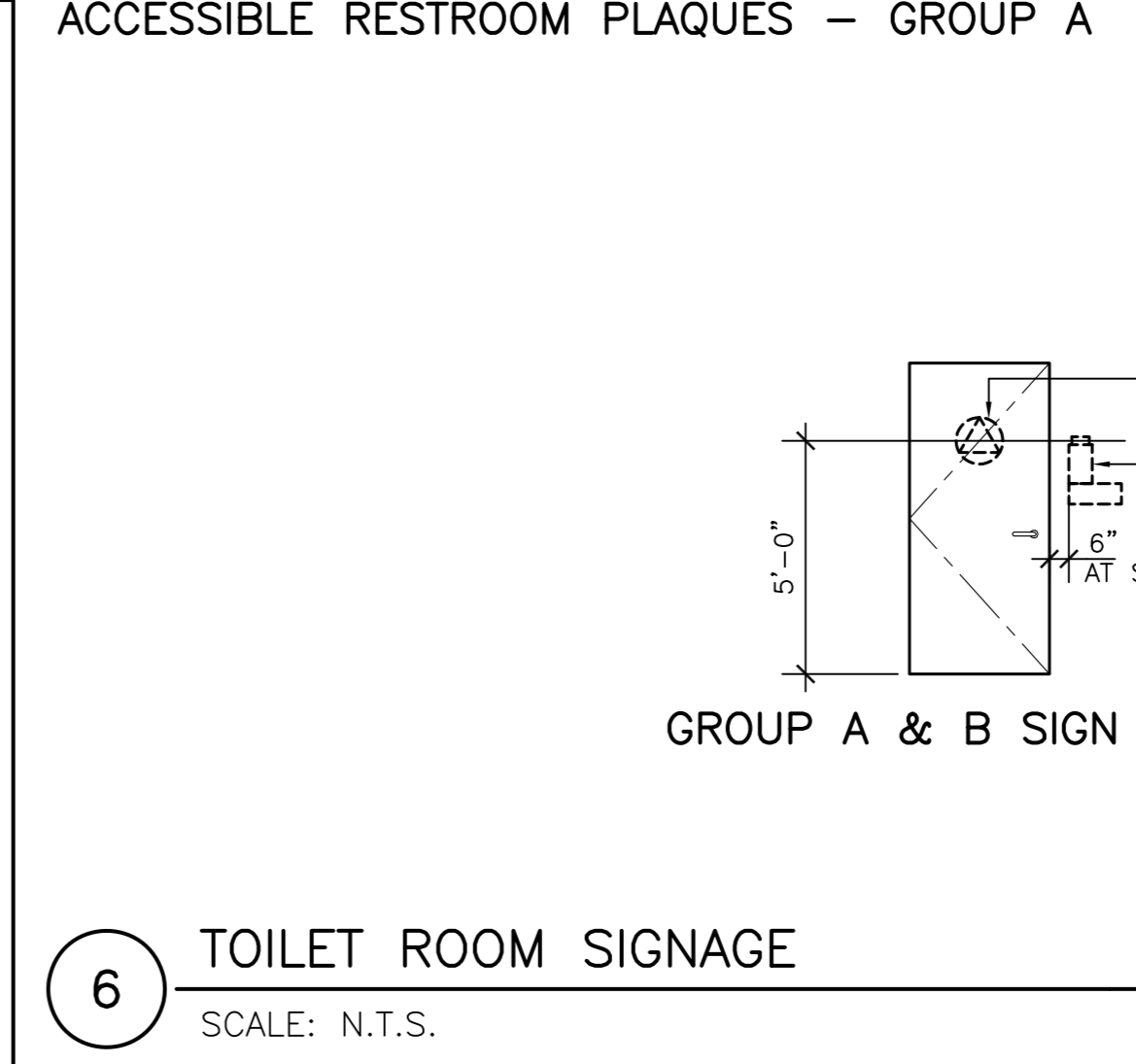
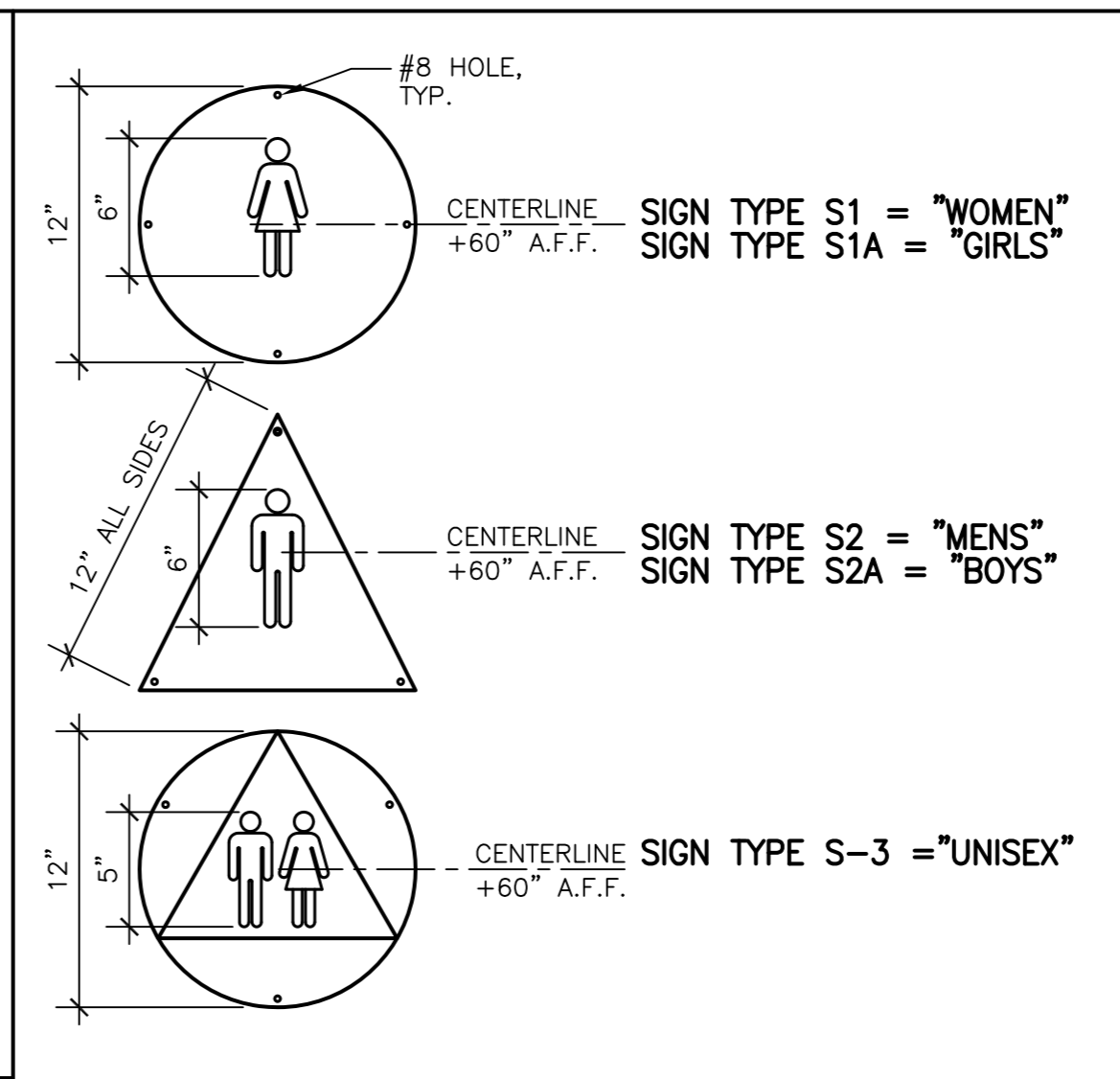
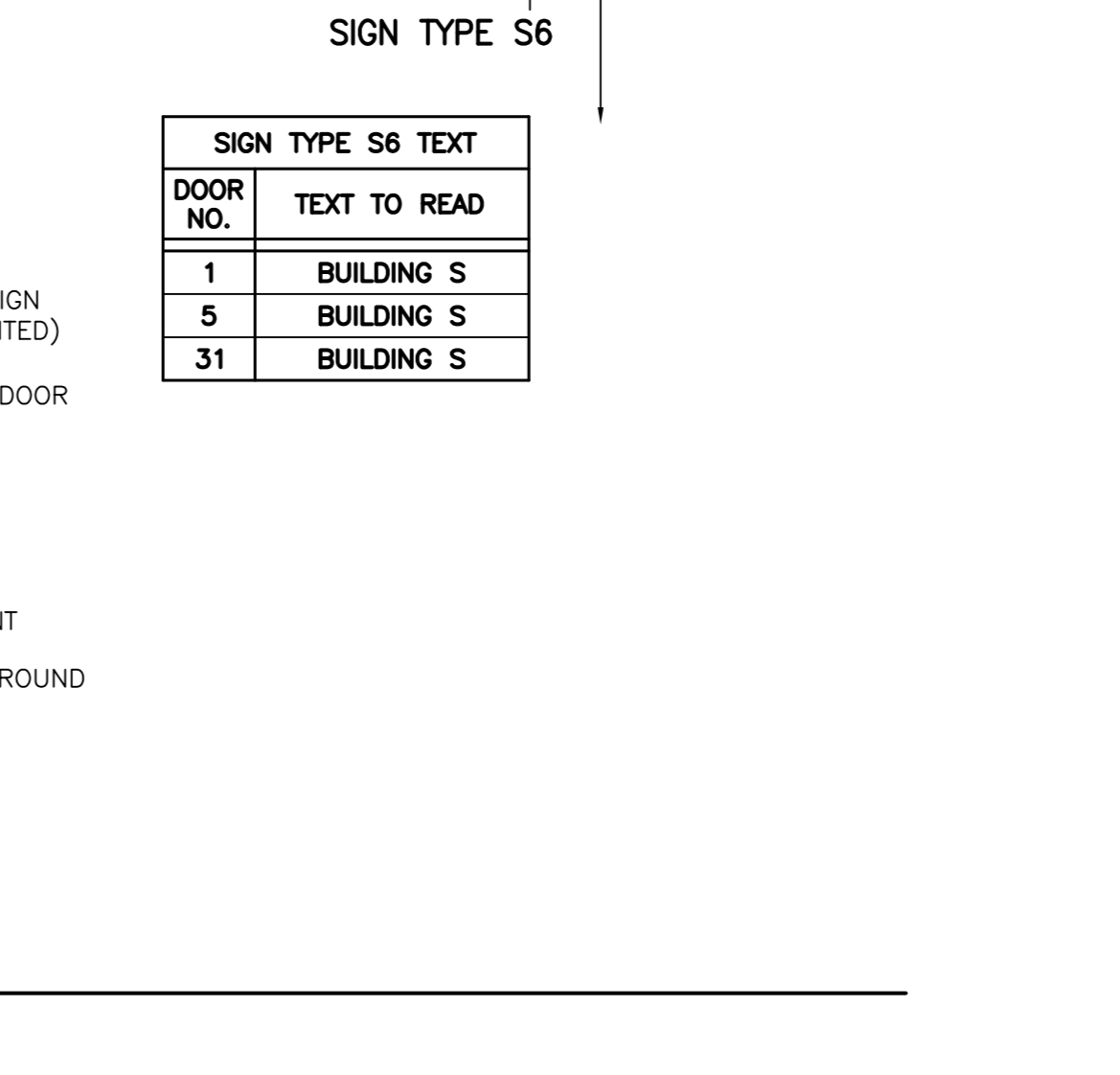
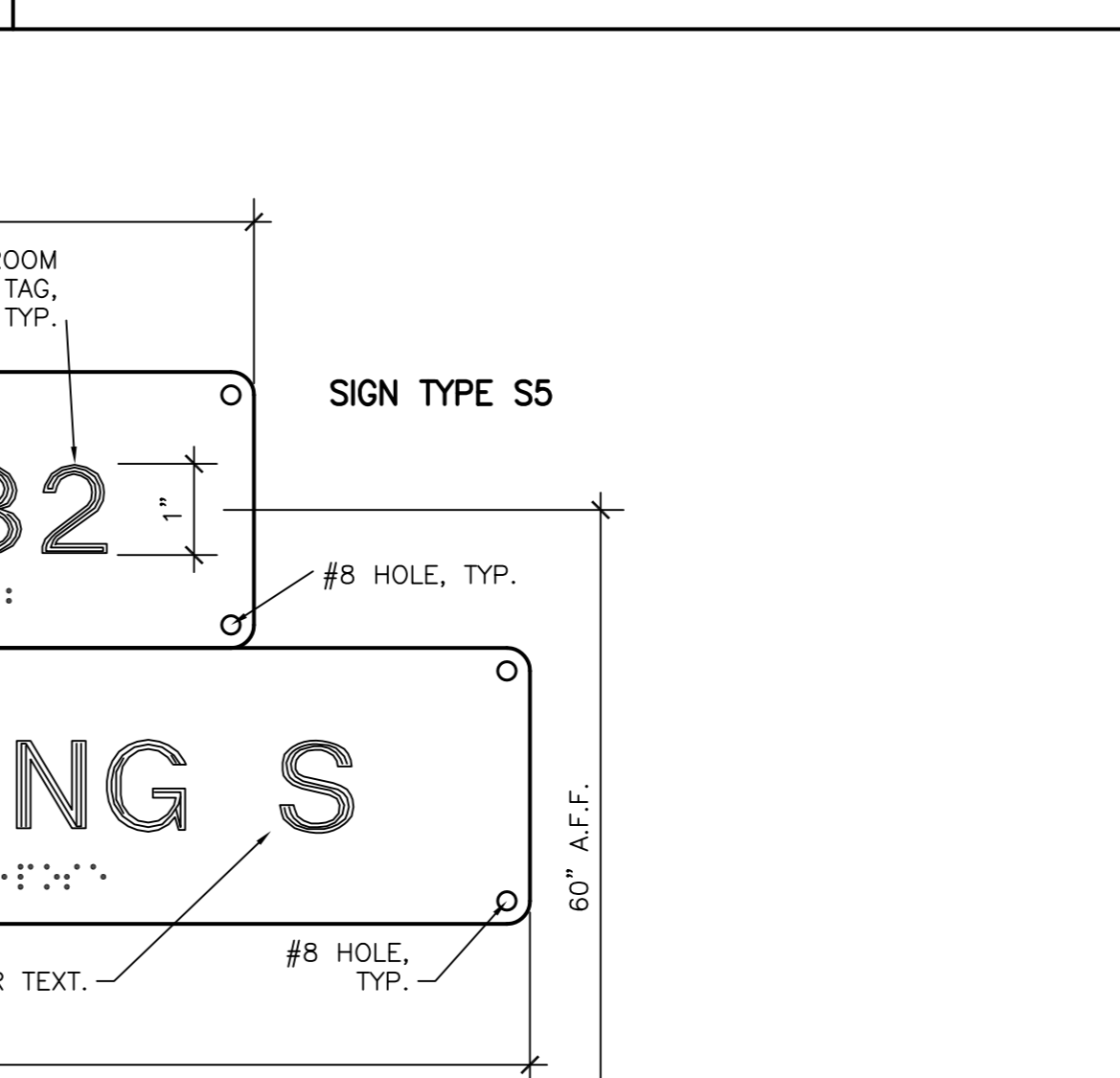
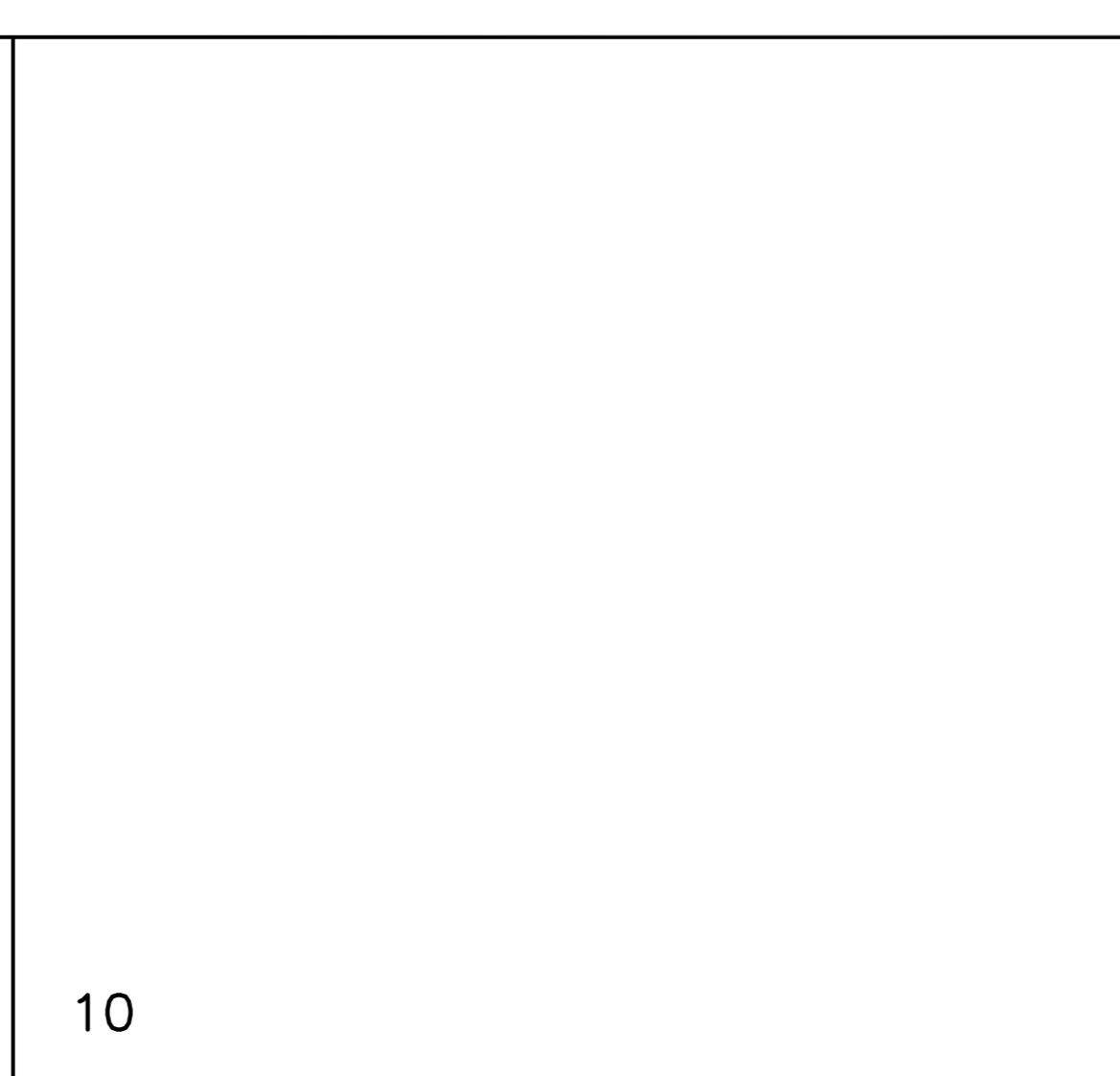
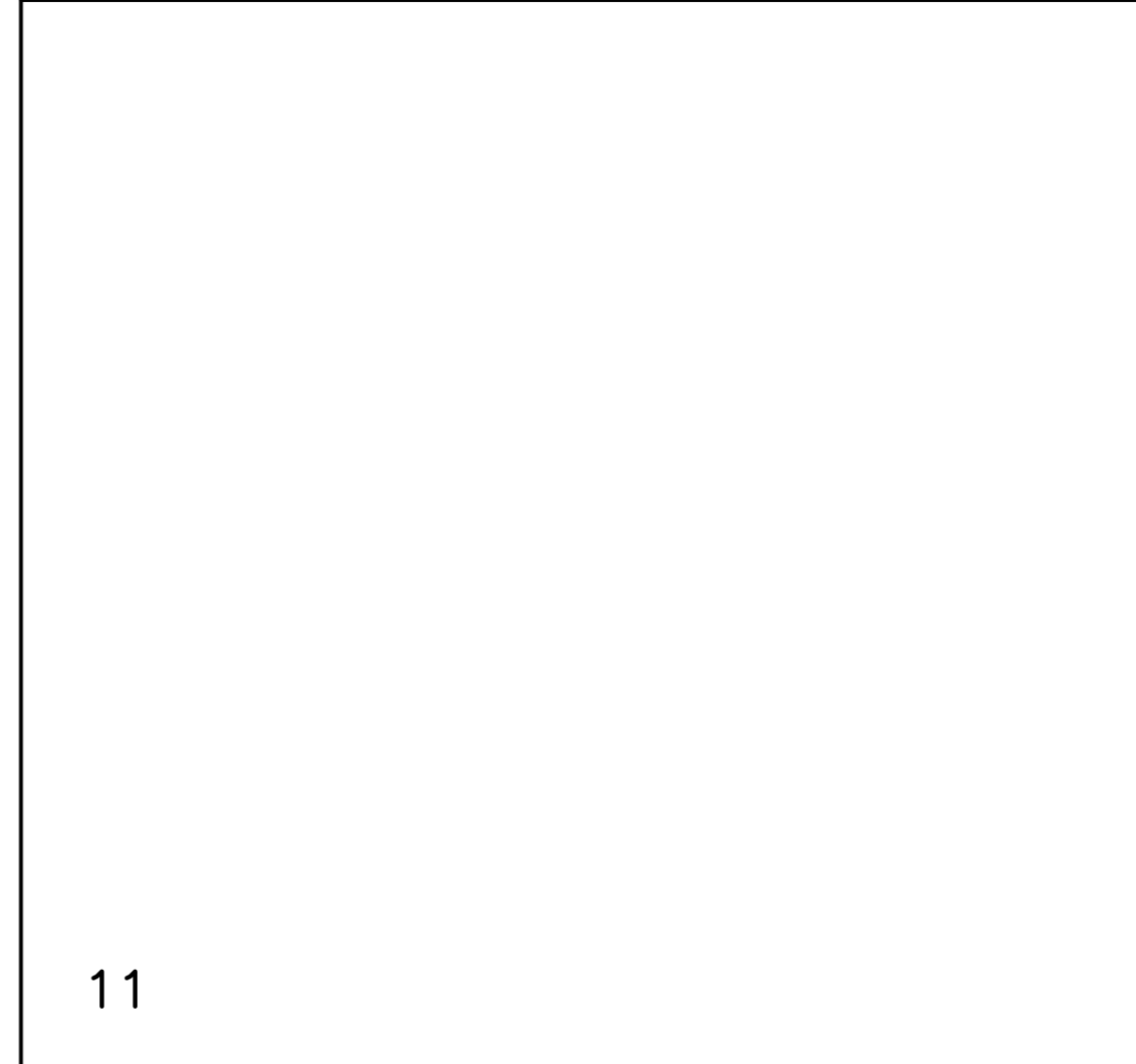
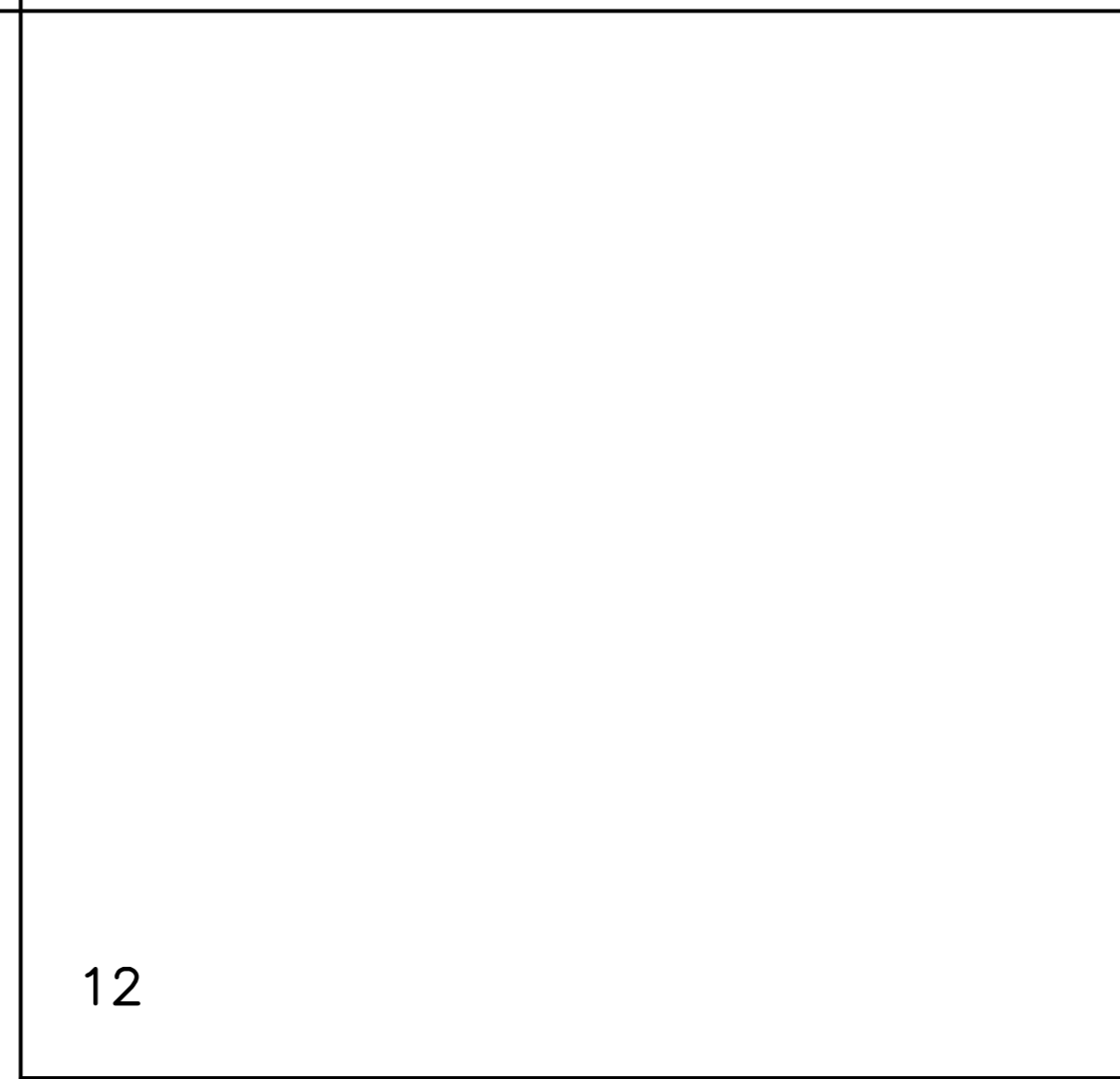
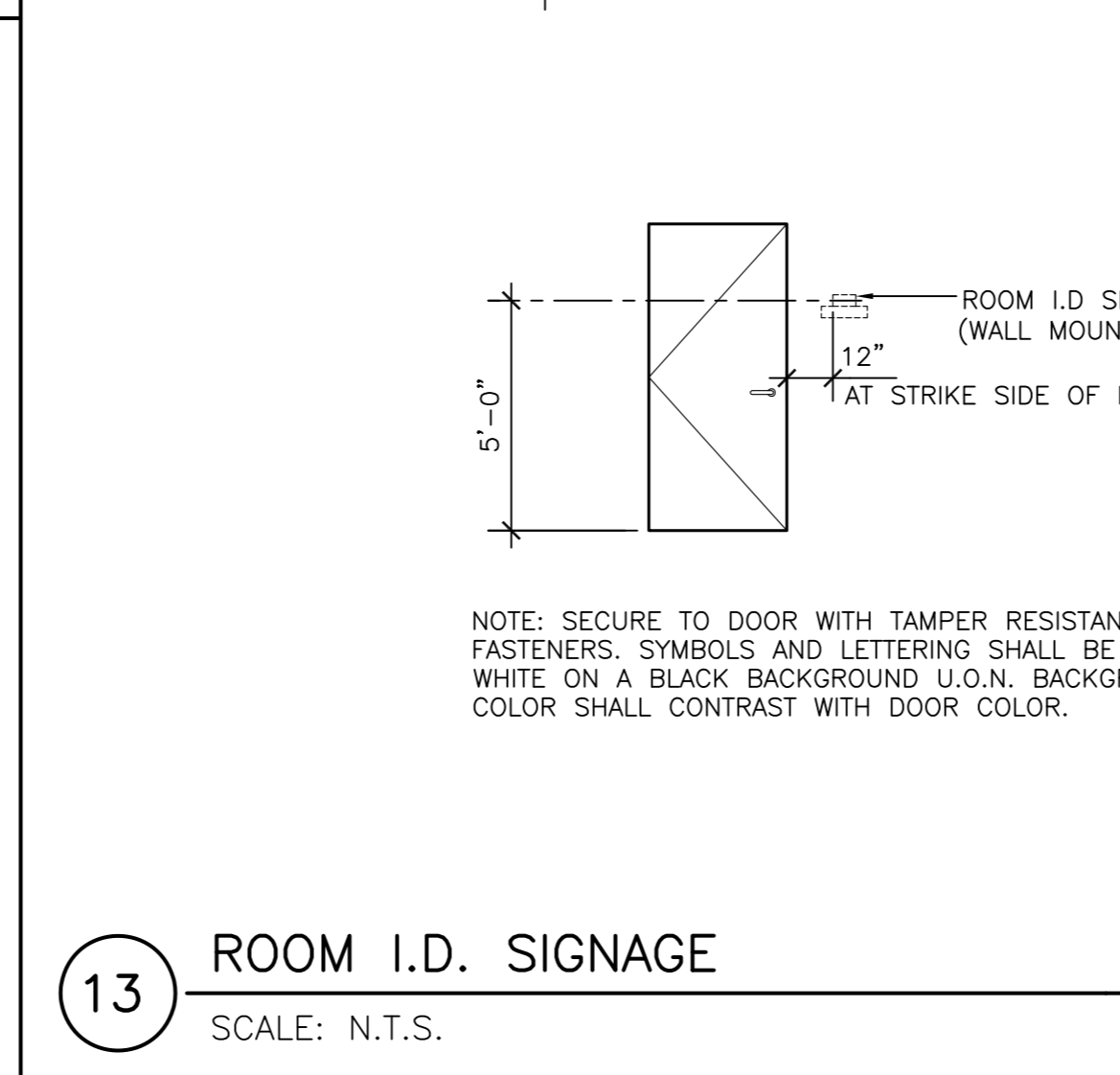
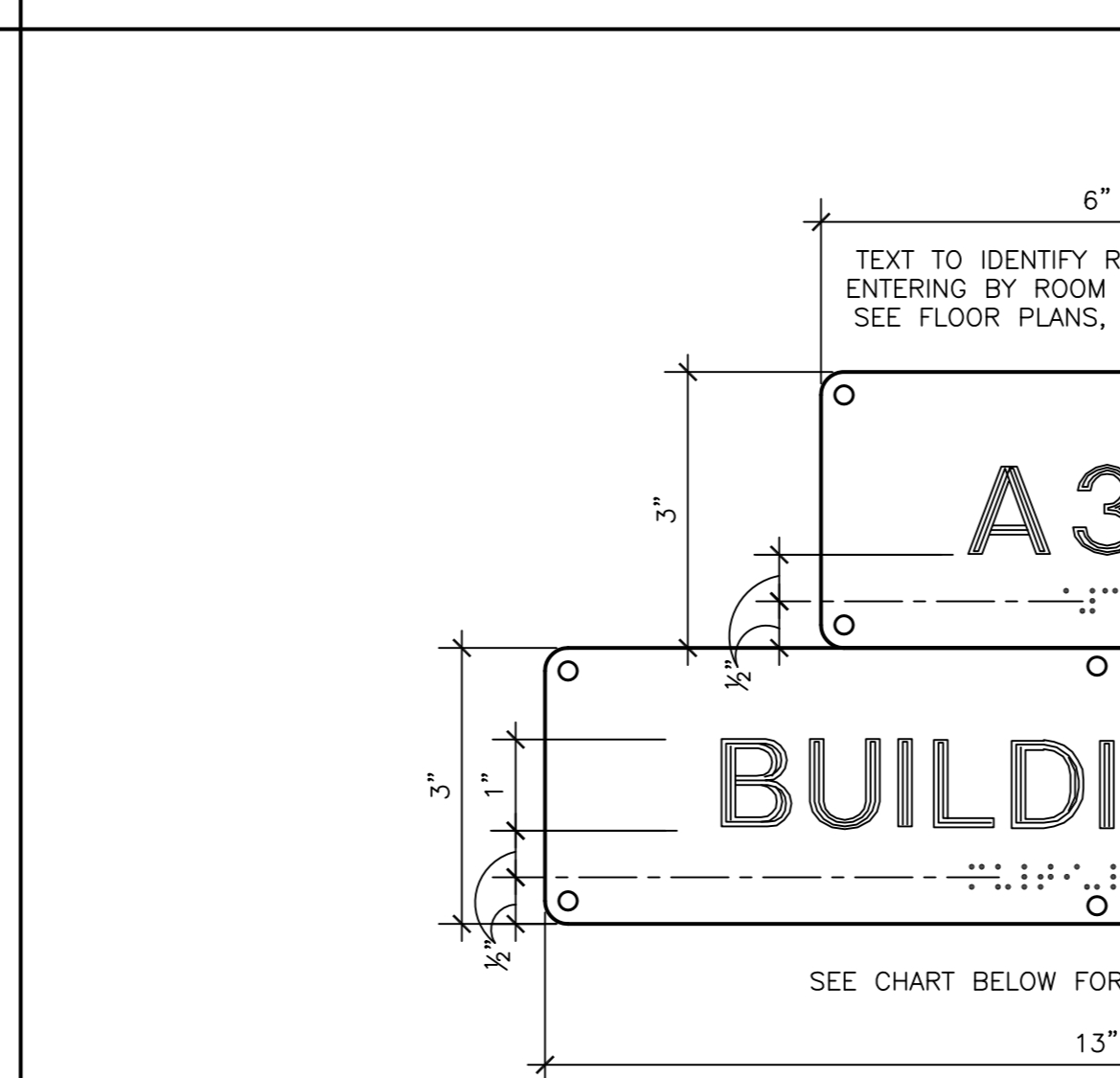
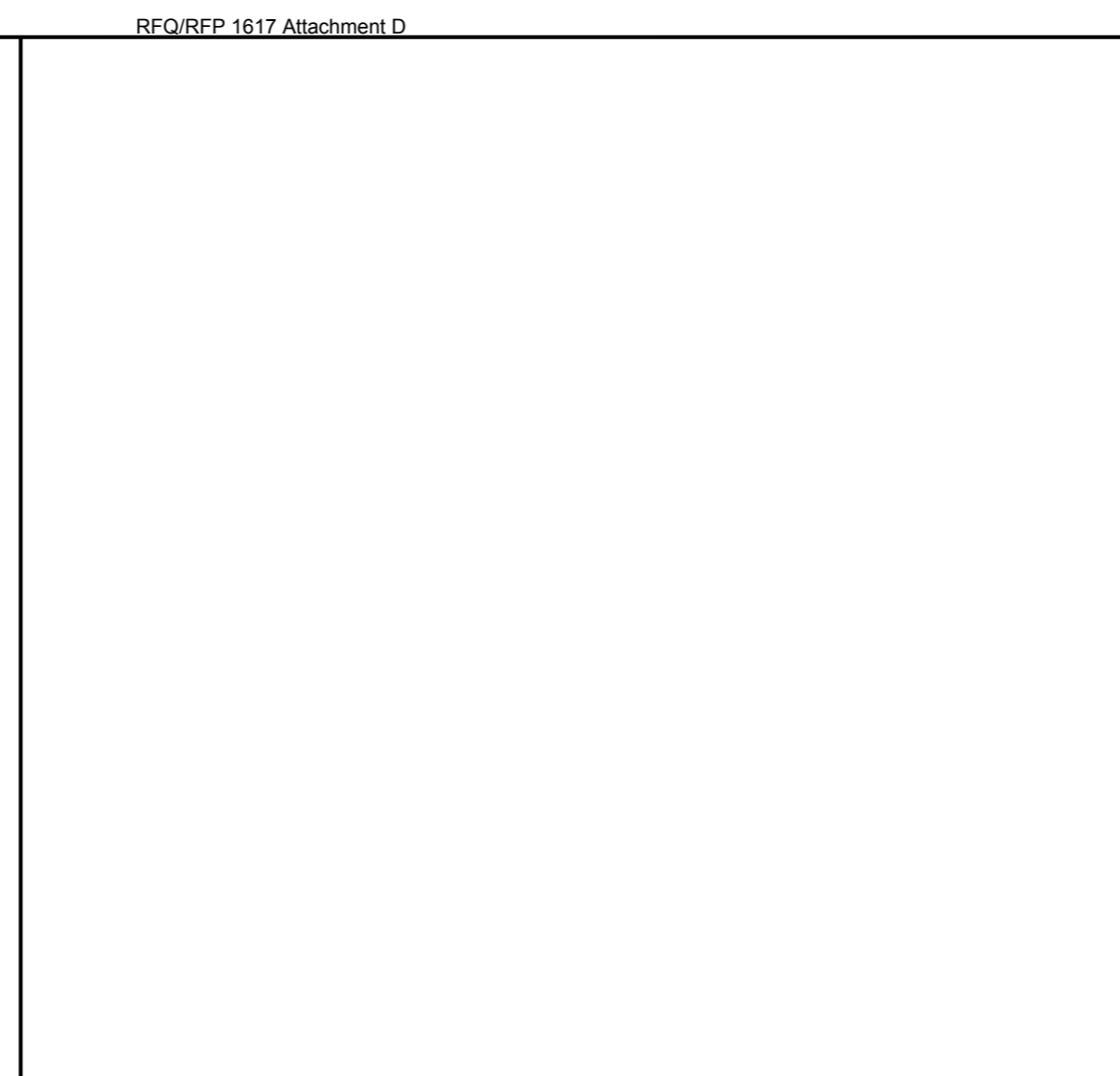
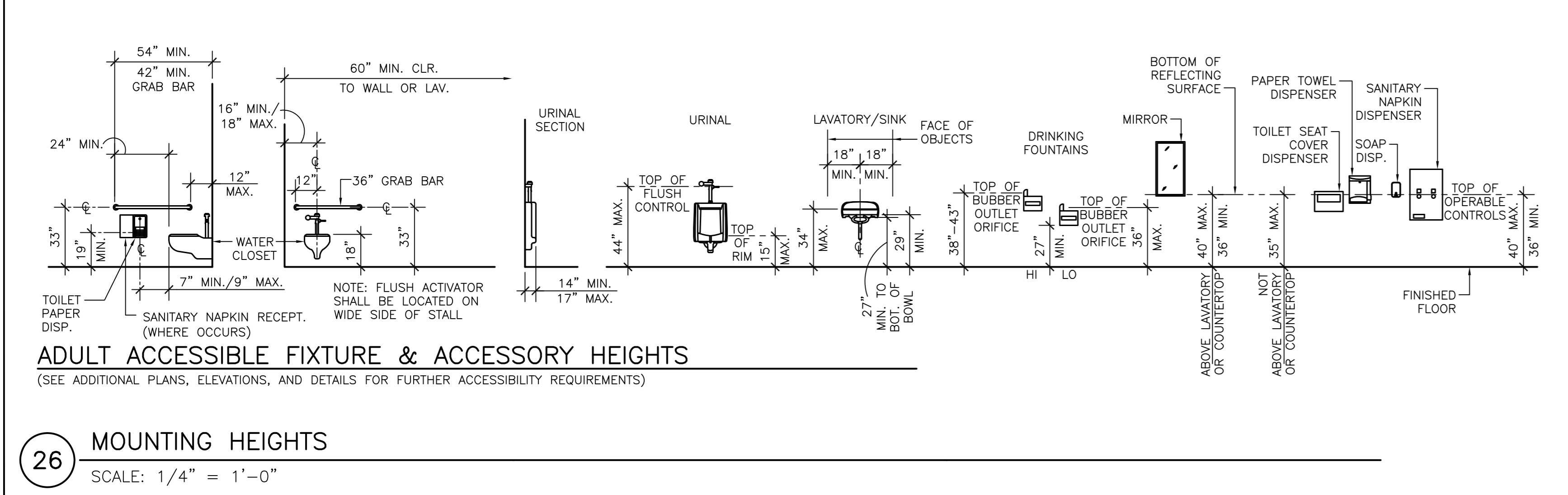
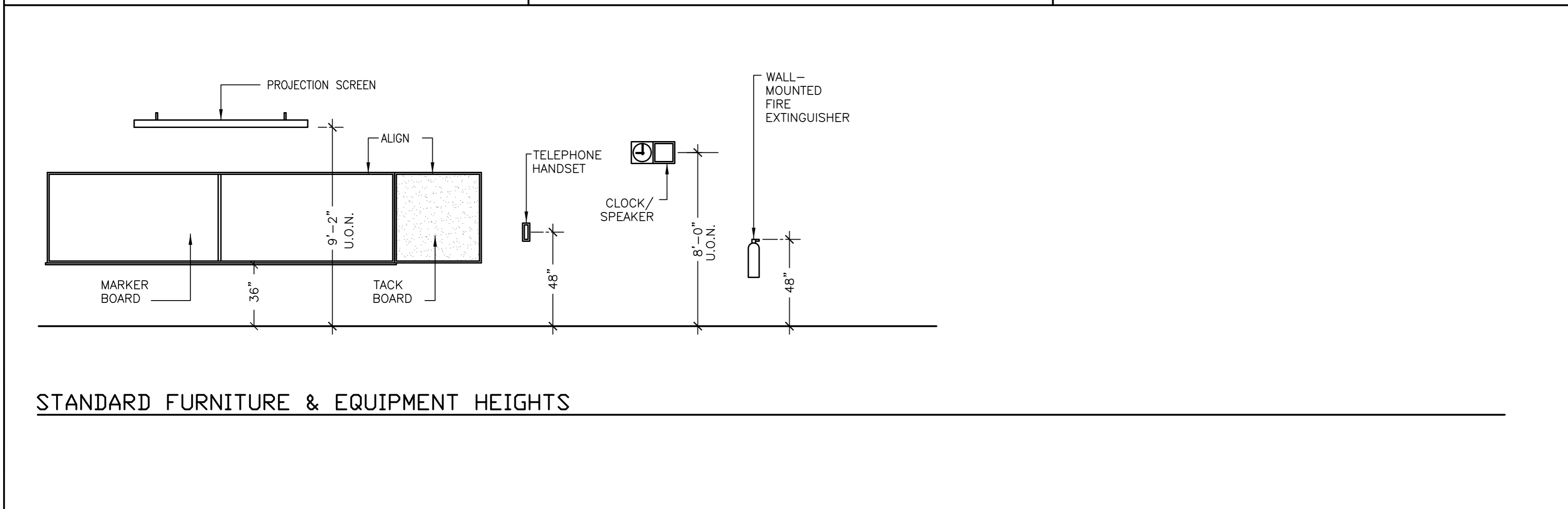

13 ROOM I.D. SIGNAGE
 SCALE: N.T.S.

12

11

5 EXIT ROUTE SIGN
 SCALE: N.T.S. (TACTILE WITH BRAILLE)

4 EXIT SIGN
 SCALE: N.T.S. (TACTILE WITH BRAILLE)

3 ACCESSIBLE ENTRANCE SIGN
 SCALE: N.T.S.

6 TOILET ROOM SIGNAGE
 SCALE: N.T.S.

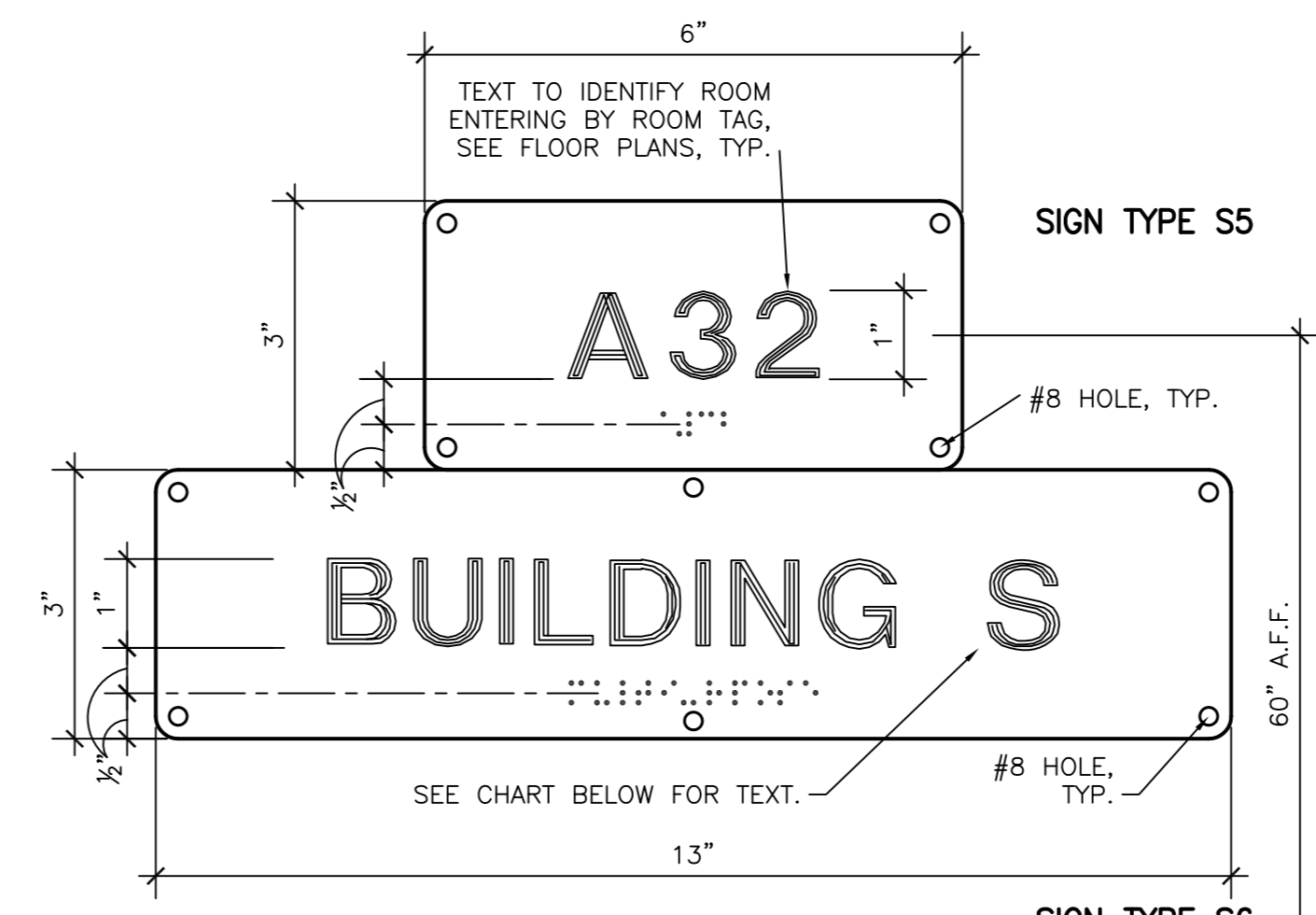

SIGN TYPE S6 TEXT	
DOOR NO.	TEXT TO READ
1	BUILDING S
5	BUILDING S
31	BUILDING S

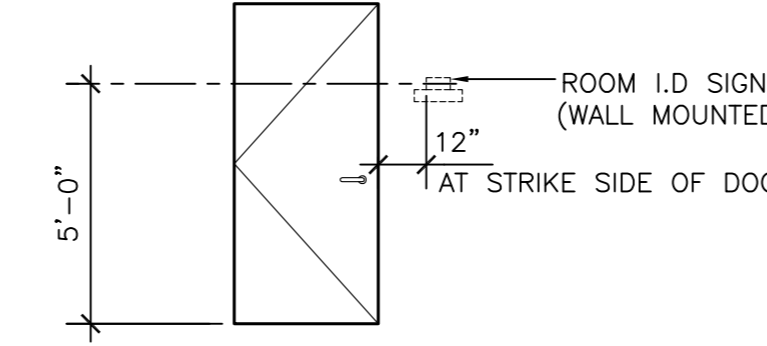

NOTE: SECURE TO DOOR WITH TAMPER RESISTANT FASTENERS. SYMBOLS AND LETTERING SHALL BE WHITE ON A BLACK BACKGROUND U.O.N. BACKGROUND COLOR SHALL CONTRAST WITH DOOR COLOR.

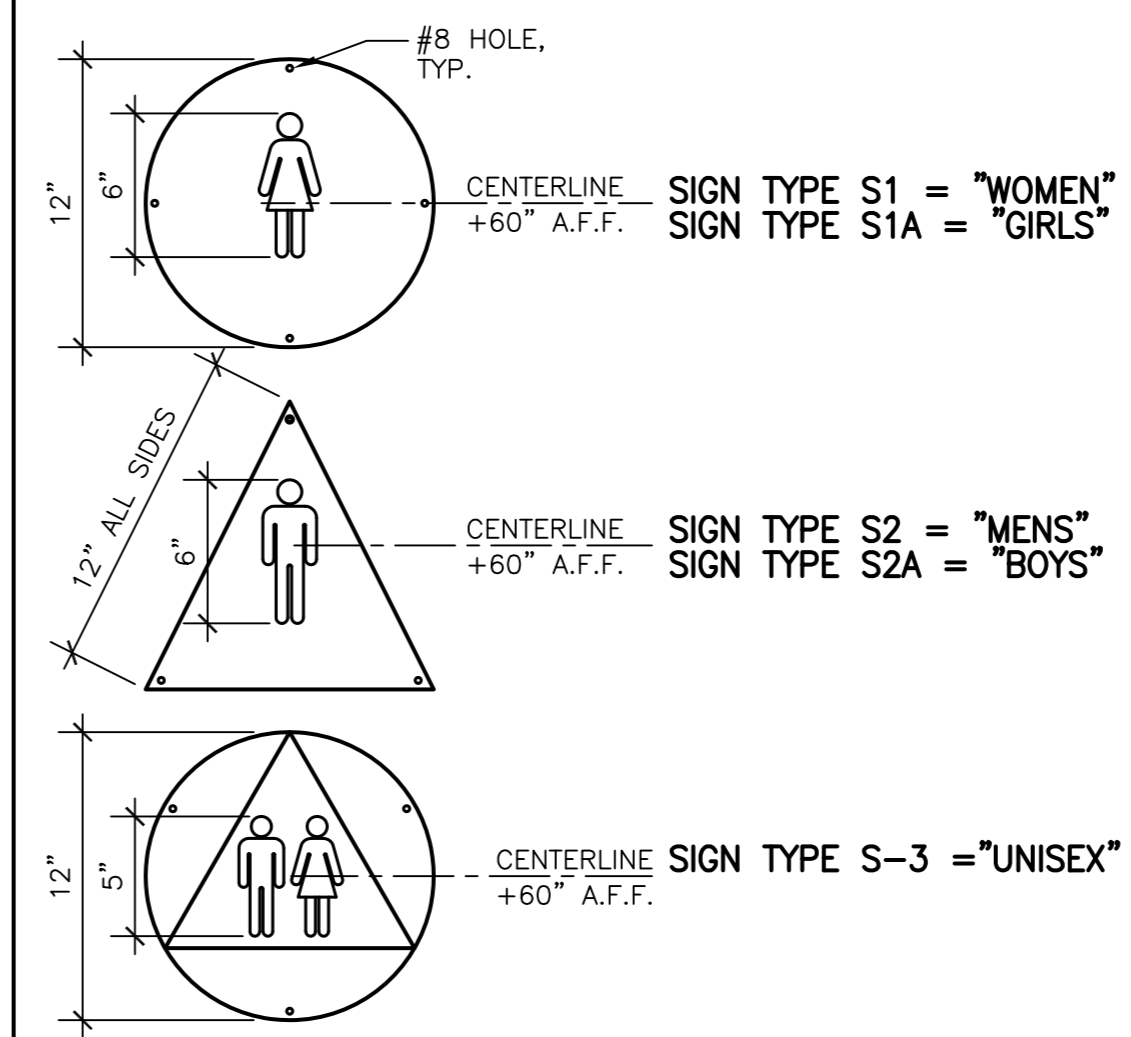

ACCESSIBLE RESTROOM PLAQUES - GROUP A

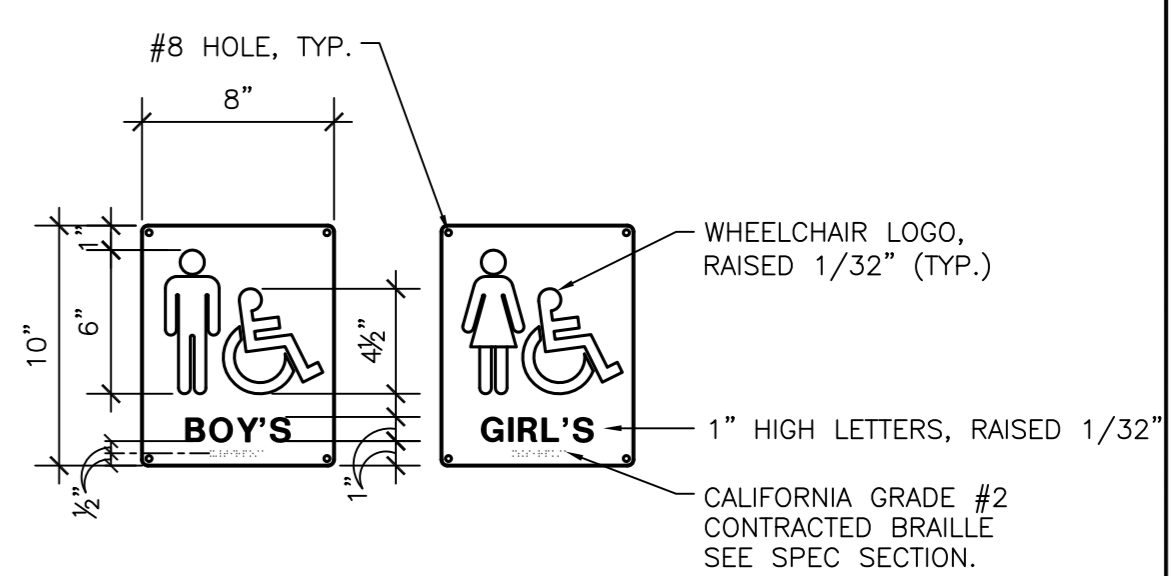

ACCESSIBLE RESTROOM PLAQUE - GROUP B

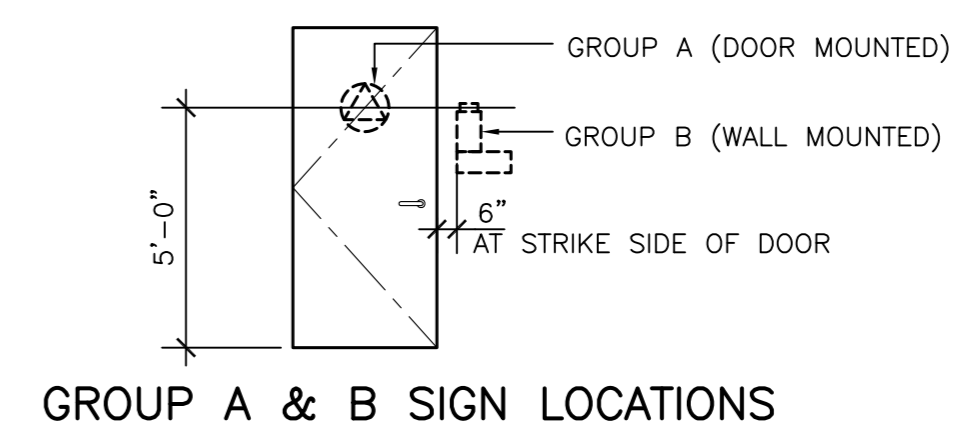

GROUP A & B SIGN LOCATIONS

STANDARD FURNITURE & EQUIPMENT HEIGHTS

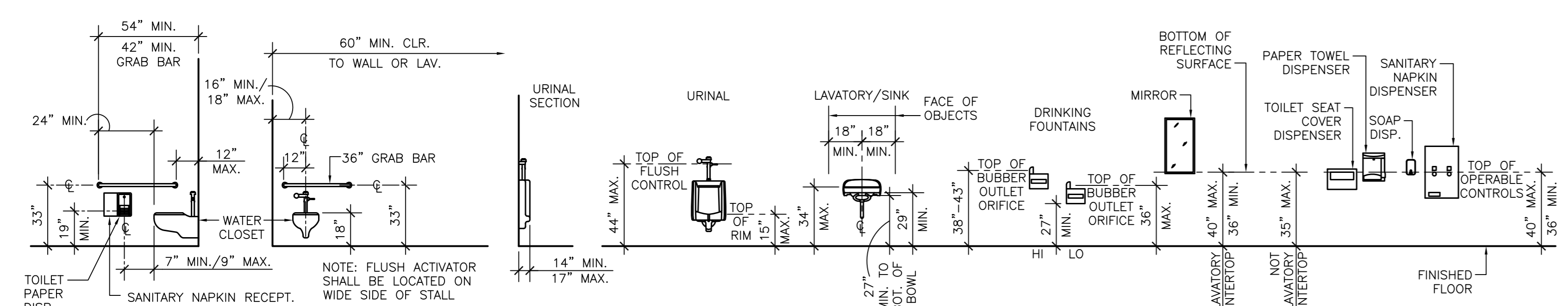

ADULT ACCESSIBLE FIXTURE & ACCESSORY HEIGHTS
 (SEE ADDITIONAL PLANS, ELEVATIONS, AND DETAILS FOR FURTHER ACCESSIBILITY REQUIREMENTS)

26 MOUNTING HEIGHTS
 SCALE: 1/4" = 1'-0"

Mt. Diablo High School
Building S - Science Lab Modernization

2450 Grant Street
 Concord, California 94520

Mt. Diablo Unified School District

MDUSD

IDENTIFICATION STAMP
 DIV. OF THE STATE ARCHITECT
 OFFICE OF REGULATION SERVICES

APPLICATION NO.
 01-
 AC. FLS. SS

DATE _____

DIVISION OF THE STATE ARCHITECT
 revision date: _____ by: _____

CONSULTANT

nacht&lewis

600 O Street, Suite 100
 Sacramento, CA 95811
 www.nachtlewis.com
 916.329.4000

ARCHITECT

REVISIONS

NO.	DESCRIPTION	DATE	REV'D

DATE February 19, 2012
 JOB NO. Y1211.00
 SHEET TITLE

SIGNAGE DETAILS

SHEET NO.
A6.3

SHEET ___ OF ___ TOTAL
 DSA SUBMITTAL SET

ONE AND ONE-HALF INCH = ONE FOOT
ONE INCH = ONE FOOT
THREE-QUARTERS INCH = ONE FOOT
ONE-HALF INCH = ONE FOOT
ONE-QUARTER INCH = ONE FOOT
ONE-EIGHTH INCH = ONE FOOT
ONE-SIXTEENTH INCH = ONE FOOT
ONE INCH = TWENTY FEET

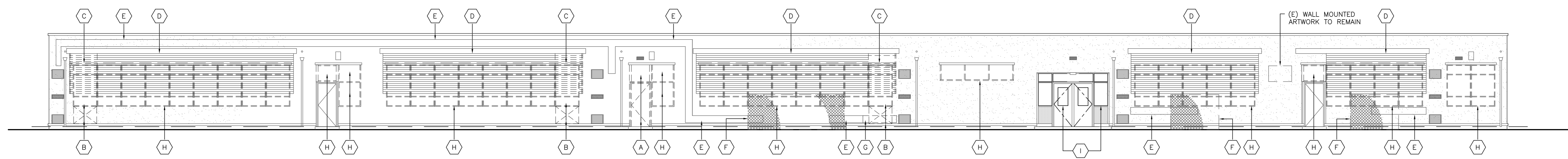

1 EXTERIOR ELEVATION - SOUTH
SCALE: 1/8"=1'-0"

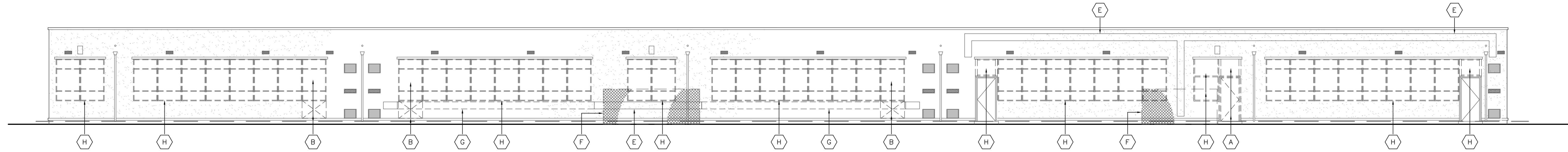

2 EXTERIOR ELEVATION - NORTH
SCALE: 1/8"=1'-0"

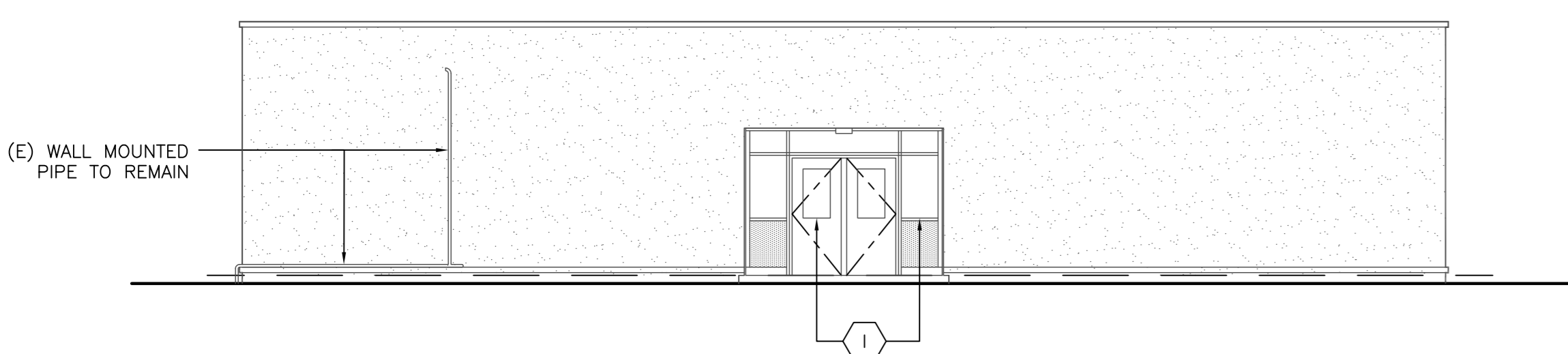

3 EXTERIOR ELEVATION - EAST
SCALE: 1/8"=1'-0"

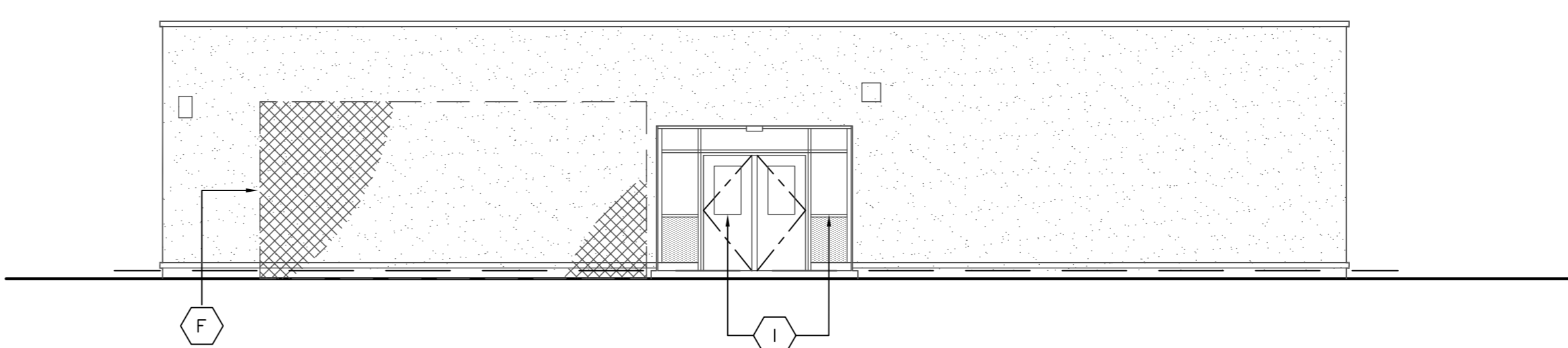

4 EXTERIOR ELEVATION - WEST
SCALE: 1/8"=1'-0"

DEMOLITION KEYNOTES

- THESE DEMOLITION KEYNOTES APPLY TO THIS SHEET ONLY
- (A) DEMO (E) DOOR, FRAME AND WINDOW ABOVE.
 - (B) DEMO PORTION OF (E) WINDOW SYSTEM, WALL AND CONCRETE CURB BELOW, TO ACCOMMODATE INSTALLATION OF NEW DOOR & DOOR FRAME.
 - (C) DEMO PORTION OF (E) EXTERIOR ALUMINUM WINDOW SHADE SYSTEM TO ALLOW ACCESS TO NEW DOOR.
 - (D) REMOVE (E) EXTERIOR ALUMINUM WINDOW SHADE SYSTEM TO ALLOW FOR REPLACEMENT OF NEW WINDOWS.
 - (E) (E) WALL MOUNTED SHROUD - TO REMAIN, UNLESS NOTED OTHERWISE.
 - (F) (E) CHAIN LINK ENCLOSURE FOR MECHANICAL/ELECTRICAL EQUIPMENT TO REMAIN, UON.
 - (G) DEMO PORTION OF (E) SHROUD TO ALLOW REFRIGERANT LINES TO BE REROUTED AS INDICATED ON MECHANICAL PLANS
 - (H) DEMO (E) WINDOW SYSTEM, SEE A8.1
 - (I) REMOVE (E) GLASS ONLY, PREP (E) FRAMES FOR INSTALLATION OF NEW GLAZING.

GENERAL SHEET NOTES

1. SEE MECHANICAL, PLUMBING, ELECTRICAL AND OTHER SHEETS FOR DEMOLITION WORK NOT SHOWN HERE.

Mt. Diablo High School
Building S - Science Lab Modernization

2480 Grant Street
 Concord, California 94520

Mt. Diablo Unified School District



FILE NO. XX-XX
 IDENTIFICATION STAMP
 DIV. OF THE STATE ARCHITECT
 OFFICE OF REGULATION SERVICES

APPLICATION NO.
 01-

AC. FLS. SS.

DATE

DIVISION OF THE STATE ARCHITECT
 revision date: by:

CONSULTANT

nacht&lewis
 600 Q Street, Suite 100
 Sacramento, CA 95811
 www.nachtlewis.com
 916.329.4000

ARCHITECT

REVISIONS

NO.	DESCRIPTION	DATE	REV'D

DATE February 19, 2012

JOB NO. Y1211.00

SHEET TITLE

Exterior Elevations - Demo Work

SHEET NO.

A7.0

SHEET ___ OF TOTAL
 DSA SUBMITTAL SET

ONE AND ONE-HALF INCH = ONE FOOT
ONE INCH = ONE FOOT
THREE-QUARTERS INCH = ONE FOOT
ONE-HALF INCH = ONE FOOT
ONE-QUARTER INCH = ONE FOOT
ONE-EIGHTH INCH = ONE FOOT
ONE-SIXTEENTH INCH = ONE FOOT
ONE INCH = TWENTY FEET

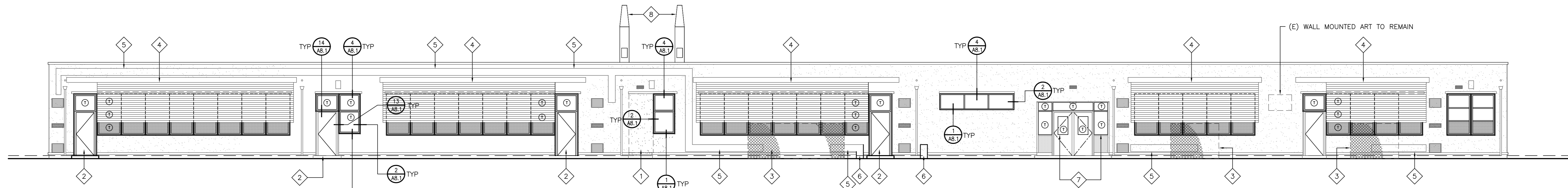

1 EXTERIOR ELEVATION - SOUTH
SCALE: 1/8"=1'-0"

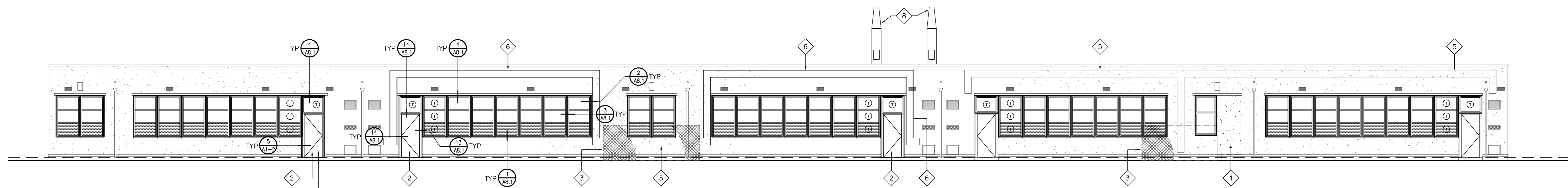

2 EXTERIOR ELEVATION - NORTH
SCALE: 1/8"=1'-0"

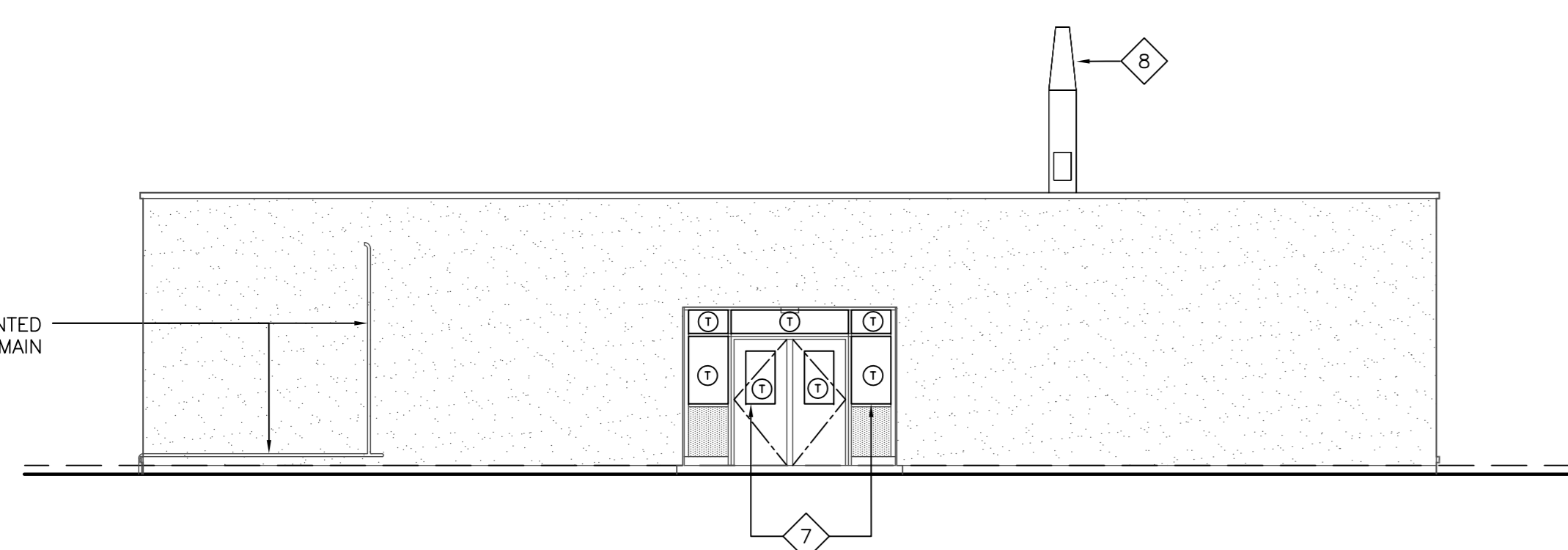

3 EXTERIOR ELEVATION - EAST
SCALE: 1/8"=1'-0"

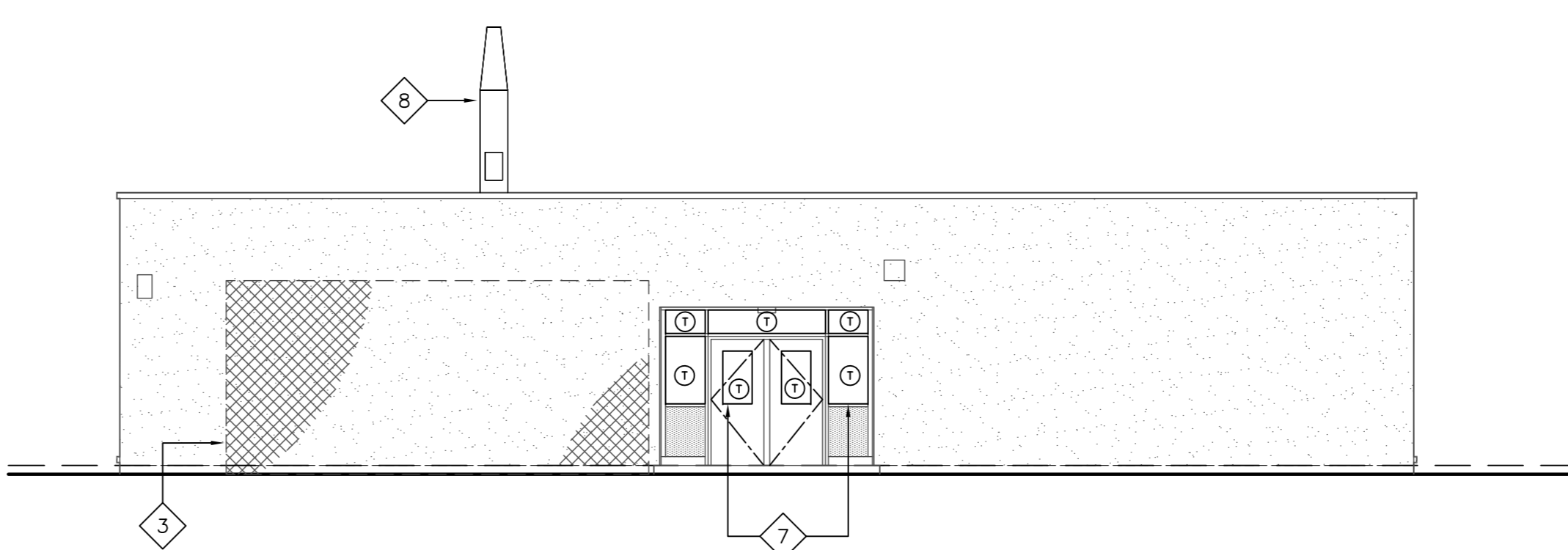

4 EXTERIOR ELEVATION - WEST
SCALE: 1/8"=1'-0"

NEW WORK KEYNOTES

THESE NEW WORK KEYNOTES APPLY TO THIS SHEET ONLY

- 1 INFILL OPENING WITH WOOD FRAMING AND CEMENT PLASTER FINISH TO MATCH EXISTING.
- 2 PROVIDE NEW DOOR AND WINDOW.
- 3 EXISTING CHAIN LINK ENCLOSURE FOR MECHANICAL/ELECTRICAL EQUIPMENT TO REMAIN.
- 4 REPLACE EXISTING EXTERIOR ALUMINUM WINDOW SHADE SYSTEM AFTER INSTALLATION OF NEW WINDOWS.
- 5 EXISTING CHASE/RACEWAY FOR HVAC REFRIGERANT LINES - TO REMAIN.
- 6 NEW CHASE/RACEWAY ROUTING FOR HVAC REFRIGERANT LINES PER MECHANICAL.
- 7 INSTALL NEW GLAZING IN FRAMES AND DOORS.
- 8 NEW EXHAUST FANS - SEE MECHANICAL DRAWINGS FOR INFORMATION NOT SHOWN HERE

GENERAL SHEET NOTES

1. SEE MECHANICAL, PLUMBING, ELECTRICAL AND OTHER SHEETS FOR NEW WORK NOT SHOWN HERE.
2. (O) INDICATES TEMPERED GLASS PANEL WHERE SHOWN
3. PAINT ALL EXISTING AND NEW WOOD WINDOW AND DOOR TRIM

Mt. Diablo High School
Building S - Science Lab Modernization

2480 Grant Street
Concord, California 94520

Mt. Diablo Unified School District

MDUSD



FILE NO. XX-XX
 IDENTIFICATION STAMP
 DIV. OF THE STATE ARCHITECT
 OFFICE OF REGULATION SERVICES
 APPLICATION NO. 01-
 AC. FLS. SS
 DATE

DIVISION OF THE STATE ARCHITECT
revision date: by:

CONSULTANT

nacht&lewis
 600 Q Street, Suite 100
 Sacramento, CA 95811
 www.nachtlewis.com
 916.329.4000

ARCHITECT

REVISIONS

NO.	DESCRIPTION	DATE	REV'D

DATE February 19, 2012

JOB NO. Y1211.00

SHEET TITLE
Exterior Elevations - New Work

SHEET NO.

A7.1

SHEET ___ OF TOTAL
DSA SUBMITTAL SET

ONE AND ONE-HALF INCH = ONE FOOT
 ONE INCH = ONE FOOT
 THREE-QUARTERS INCH = ONE FOOT
 ONE-HALF INCH = ONE FOOT
 ONE-QUARTER INCH = ONE FOOT
 ONE-EIGHTH INCH = ONE FOOT
 ONE-SIXTEENTH INCH = ONE FOOT
 ONE INCH = TWENTY FEET

30 GENERAL SHEET NOTES
SCALE: N.T.S.

1. CASEWORK MANUFACTURER SHALL NOTE ATTACHMENT DETAIL AND MAKE ACCOMMODATIONS FOR WALL LEDGERS AND SUB-TOP IN CASEWORK FABRICATION.

2. AT ALL FREE-STANDING VERTICAL CASEWORK LEGS, PROVIDE (1) ANGLE CLIP SIMILAR TO DETAIL 3/AB.0 AT FRONT AND REAR OF LEG WITH 1/4" X 2" EXPANSION BOLT INTO CONCRETE FLOORING.

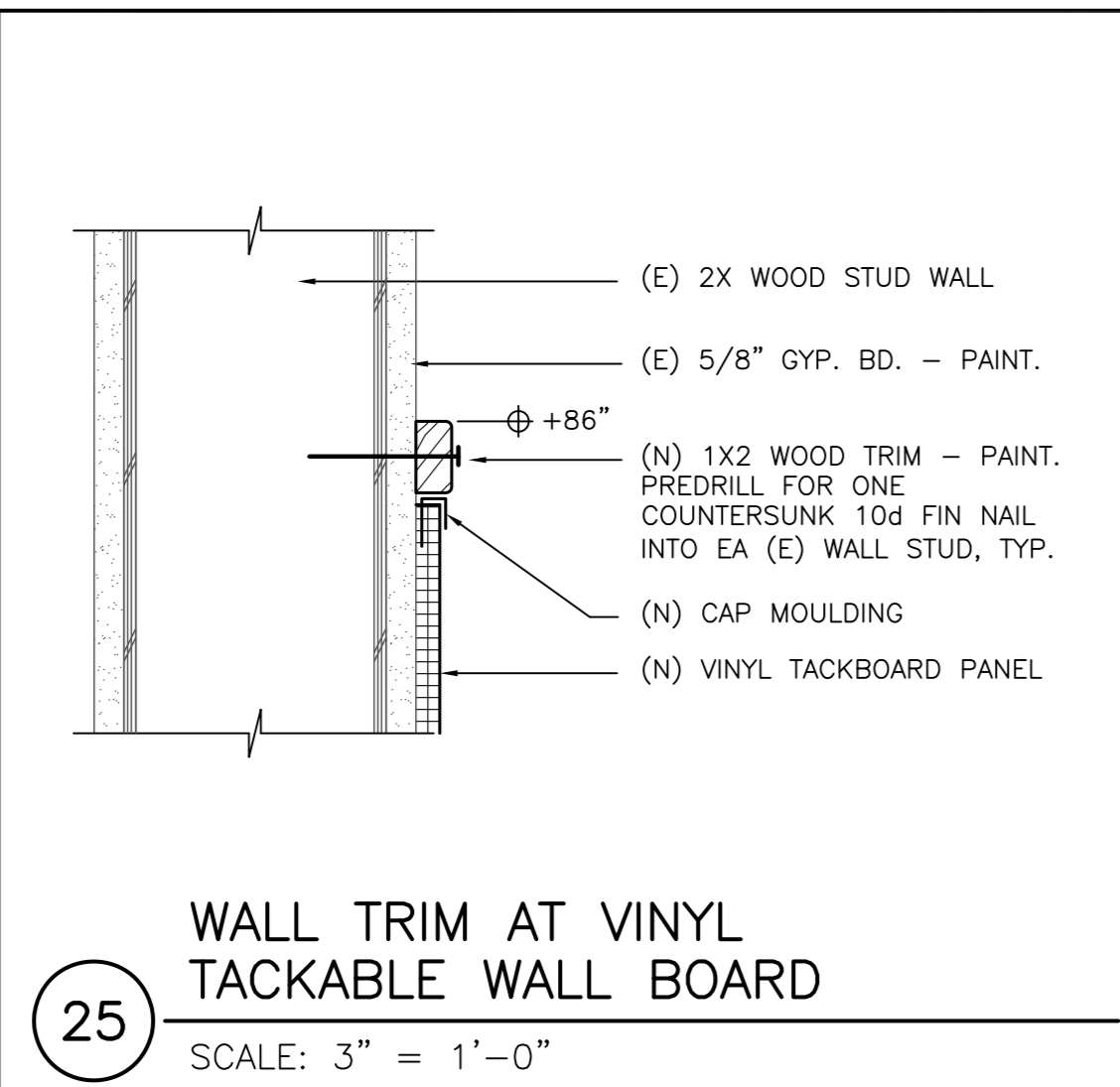

25 WALL TRIM AT VINYL TACKABLE WALL BOARD
SCALE: 3" = 1'-0"

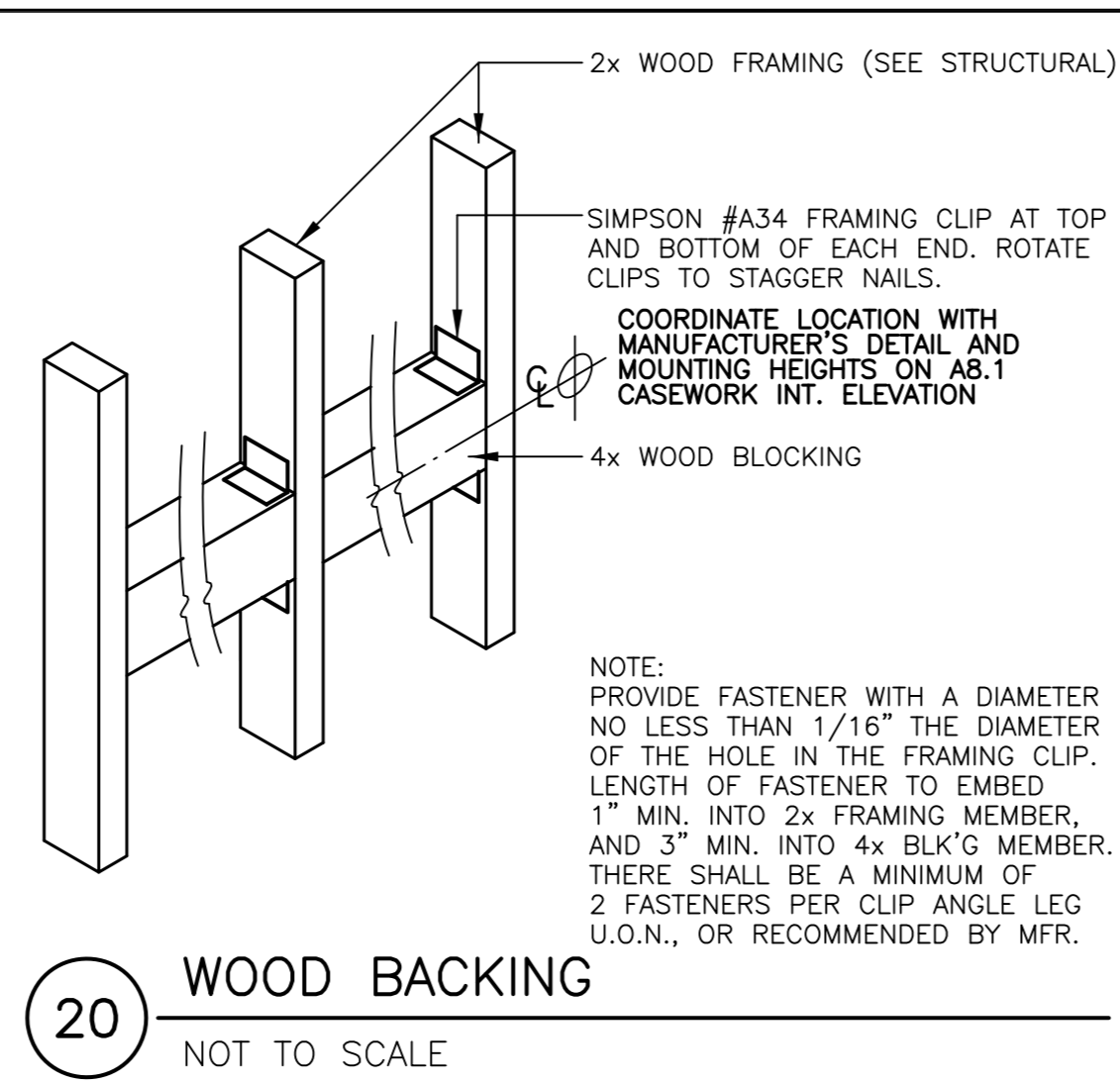

20 WOOD BACKING
NOT TO SCALE

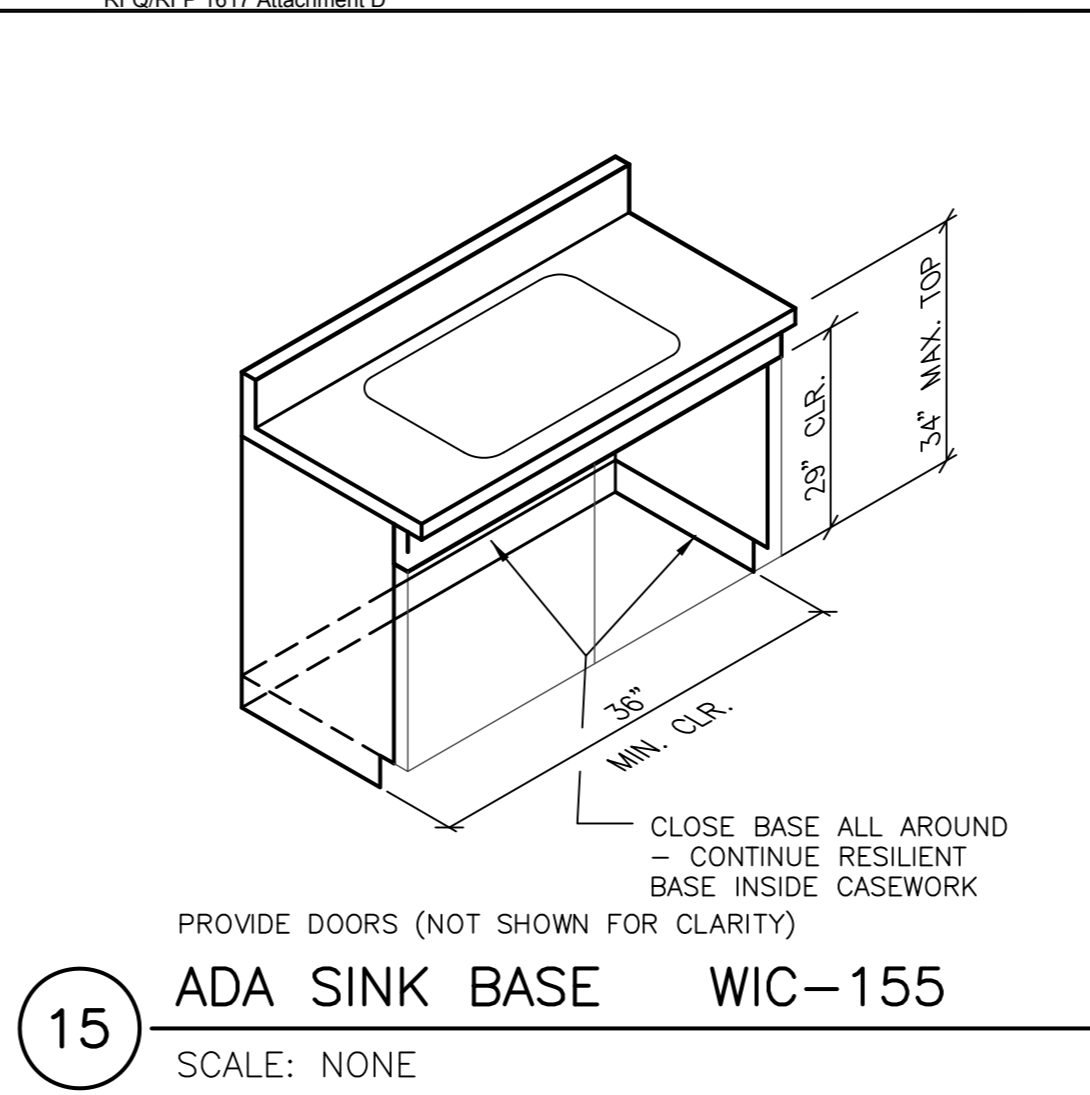

15 ADA SINK BASE WIC-155
SCALE: NONE

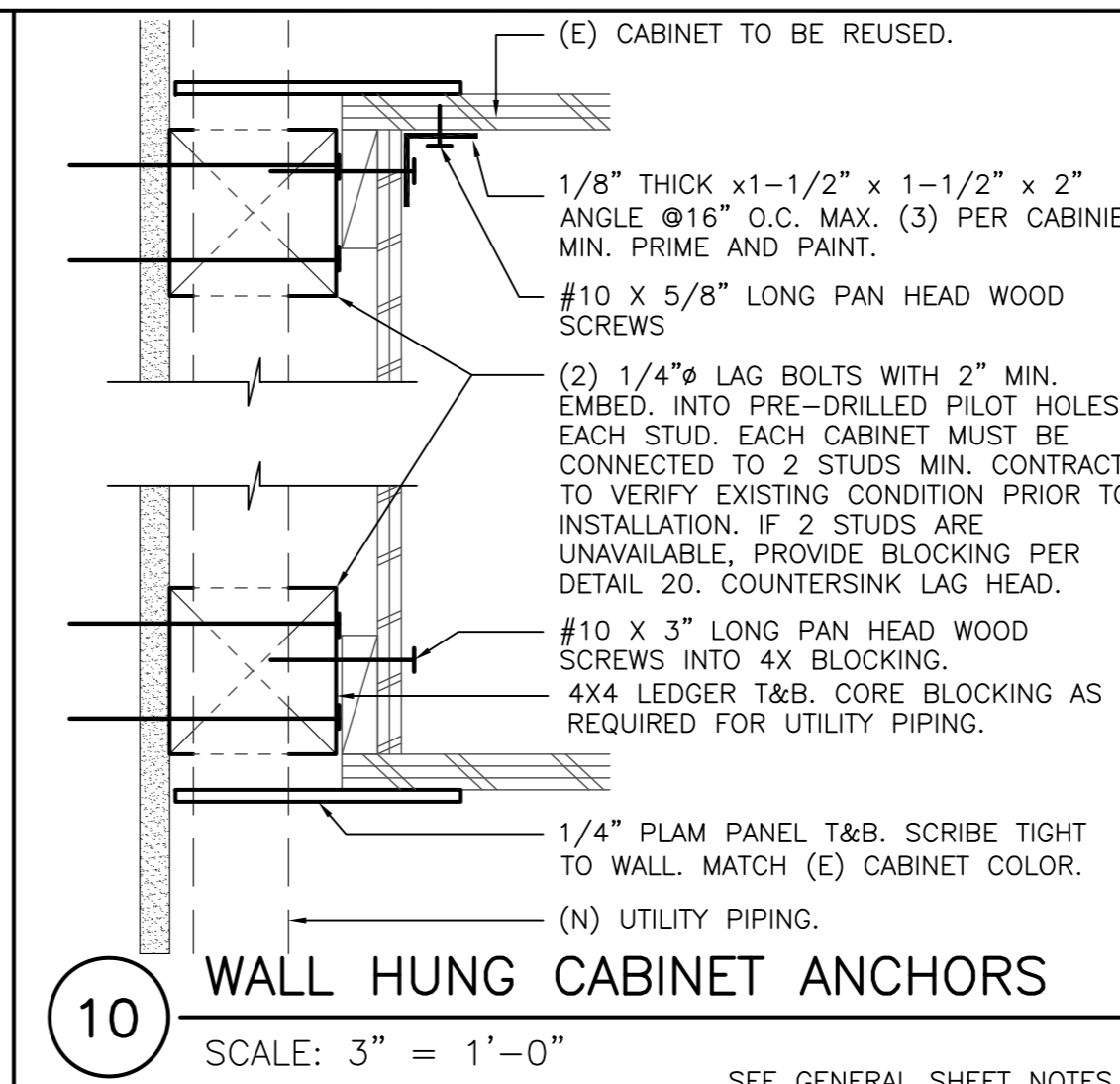

10 WALL HUNG CABINET ANCHORS
SCALE: 3" = 1'-0" SEE GENERAL SHEET NOTES

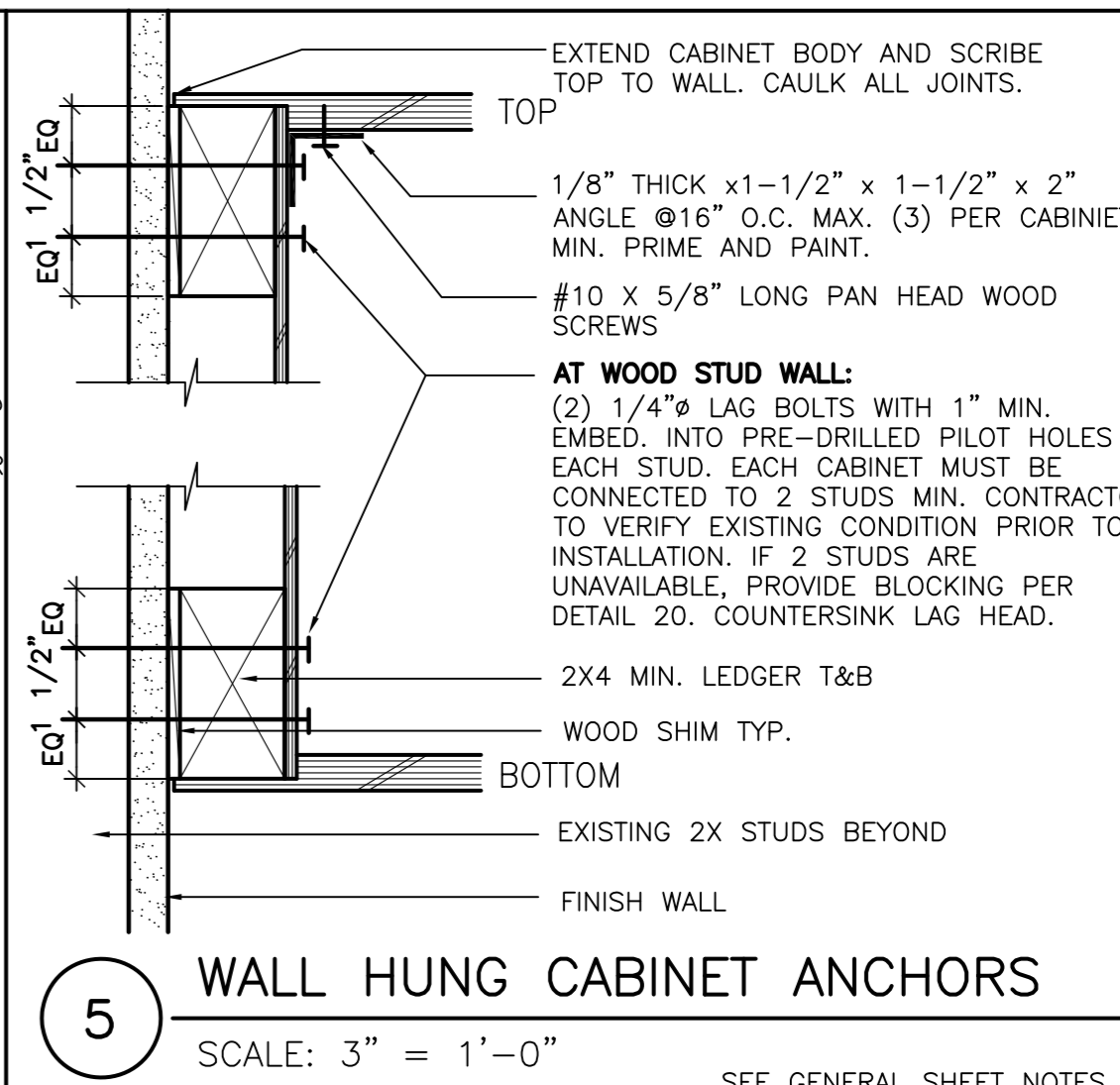

5 WALL HUNG CABINET ANCHORS
SCALE: 3" = 1'-0" SEE GENERAL SHEET NOTES

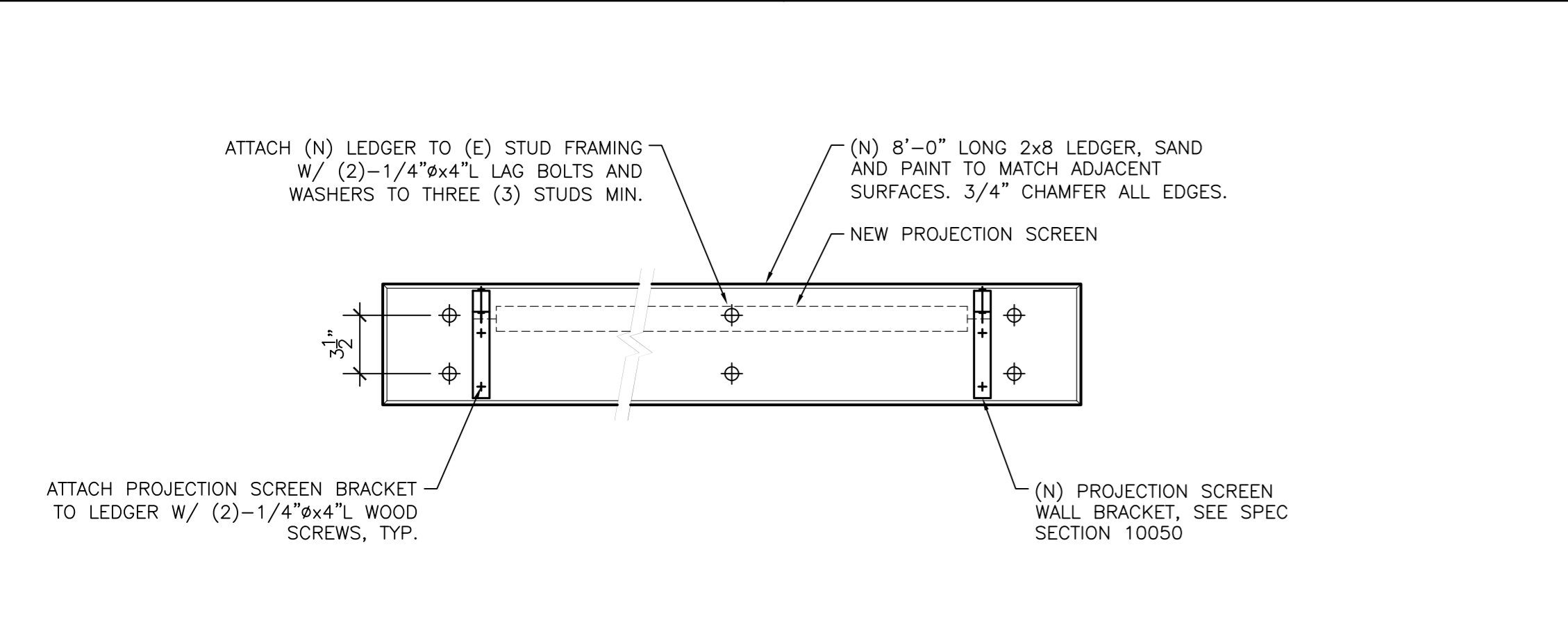

29 NEW PROJECTION SCREEN BRACKET
SCALE: 1 1/2" = 1'-0"

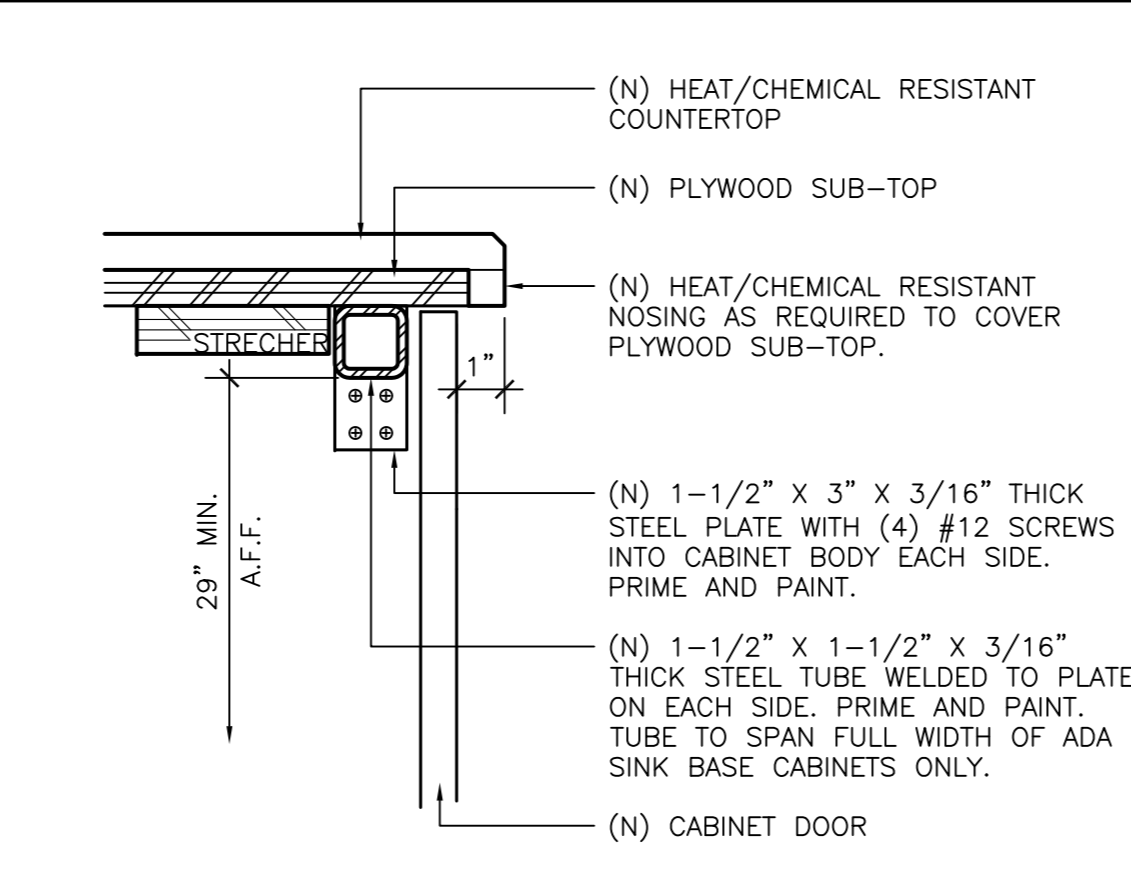

19 BASE CABINET FRONT EDGE AT ACCESSIBLE SINK
SCALE: 3" = 1'-0"

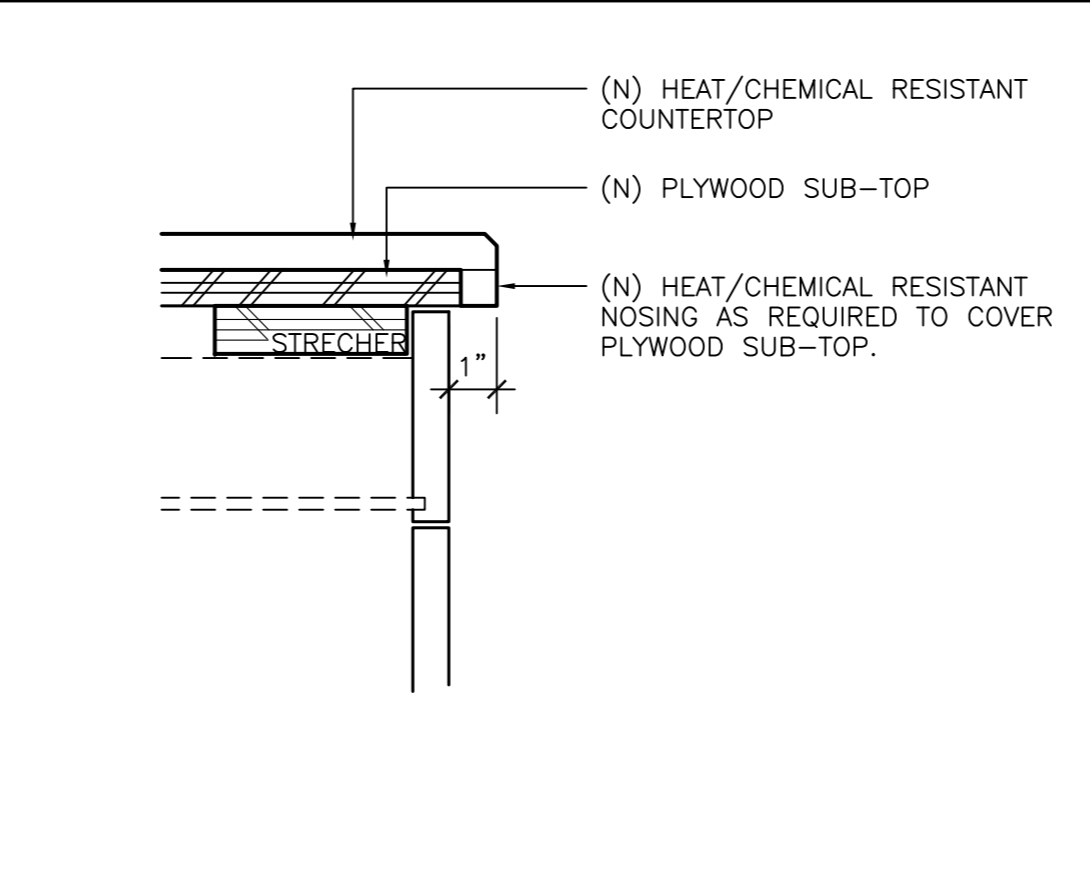

14 BASE CABINET FRONT EDGE
SCALE: 3" = 1'-0"



9 NOT USED
SCALE: 3" = 1'-0"

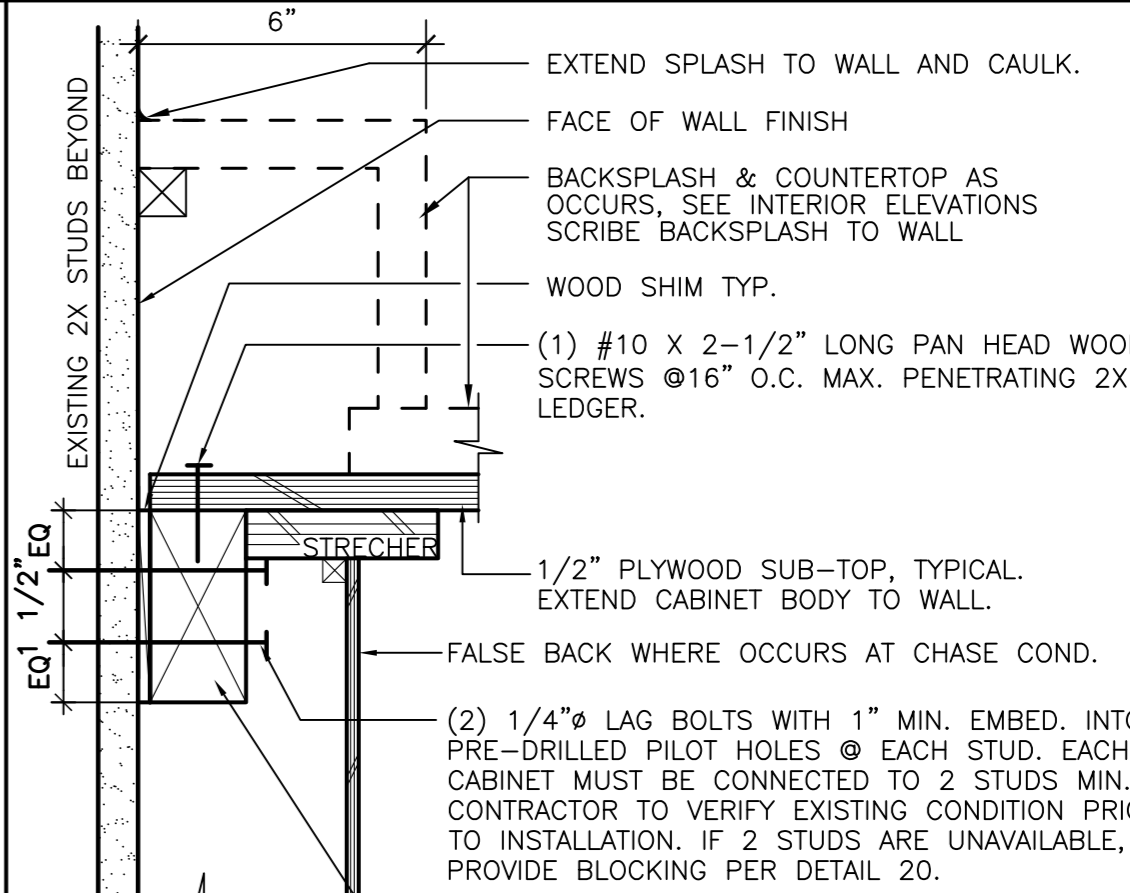

4 BASE CABINET ANCHOR W/ CHASE
SCALE: 3" = 1'-0" SEE GENERAL SHEET NOTES

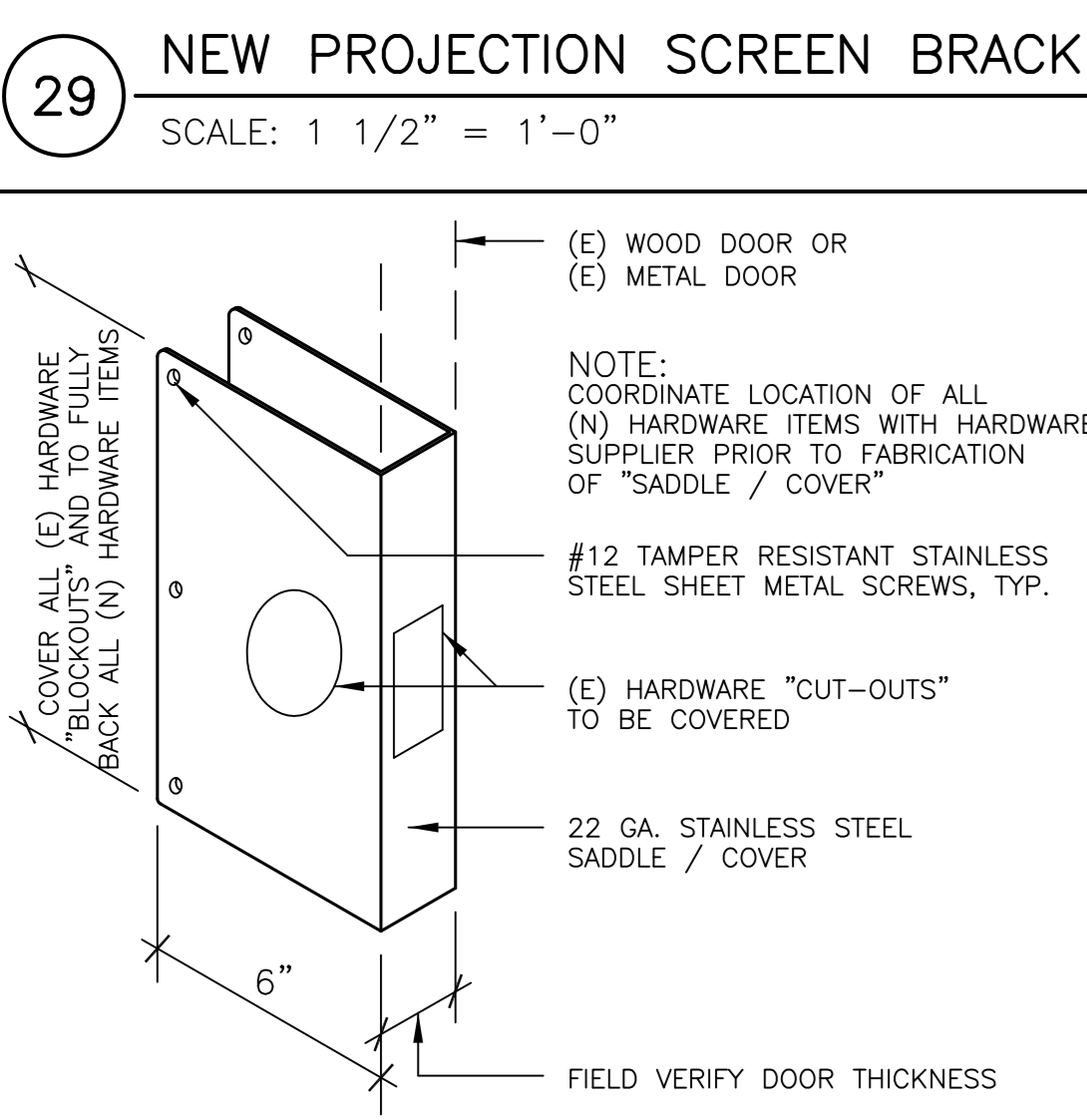

28 DOOR SADDLE / COVER
SCALE: N.T.S.

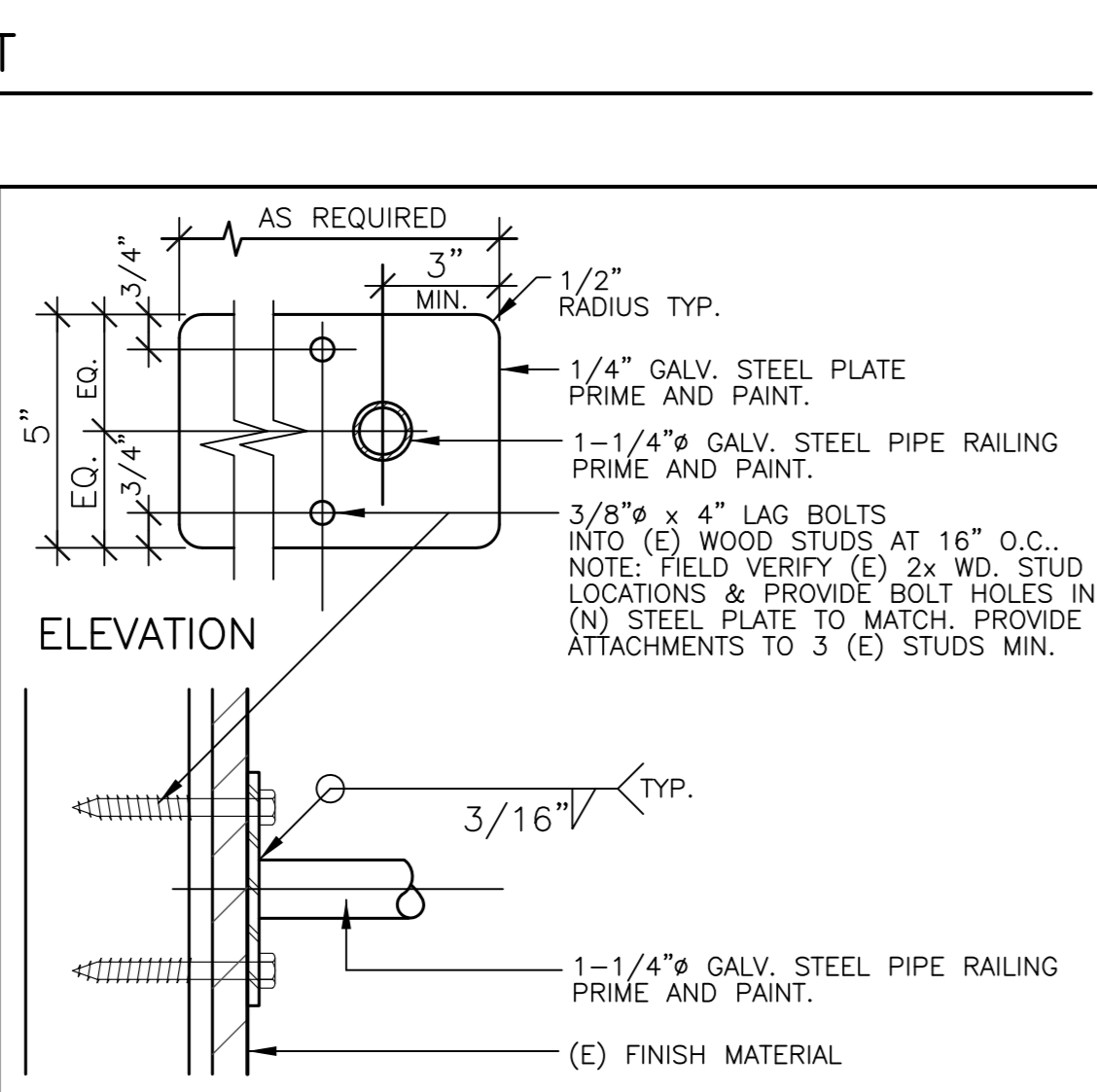

23 PIPE ANCHOR AT NON-MASONRY WALL
SCALE: 3" = 1'-0"

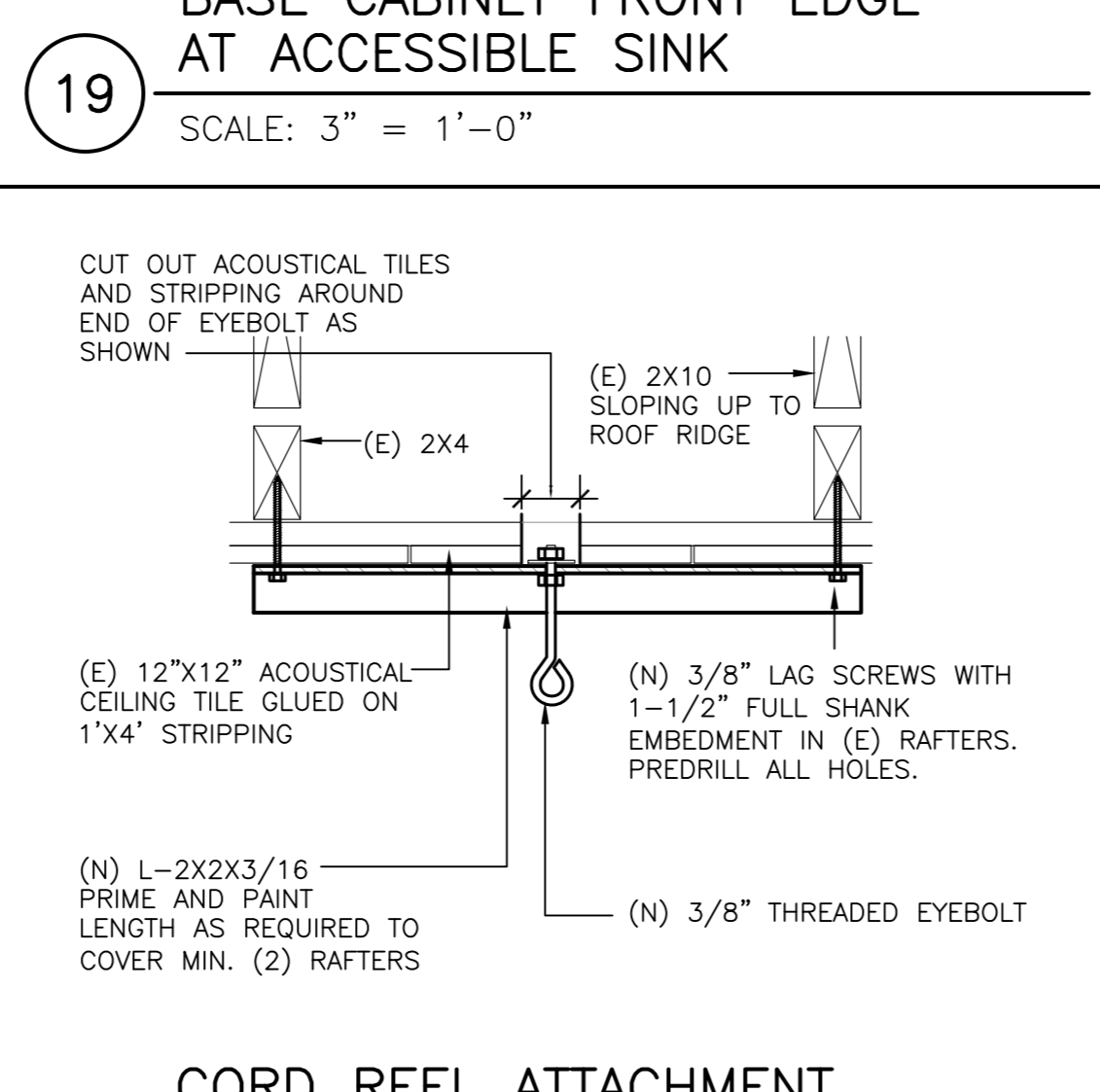

18 CORD REEL ATTACHMENT - WOOD JOIST
SCALE: 1 1/2" = 1'-0"

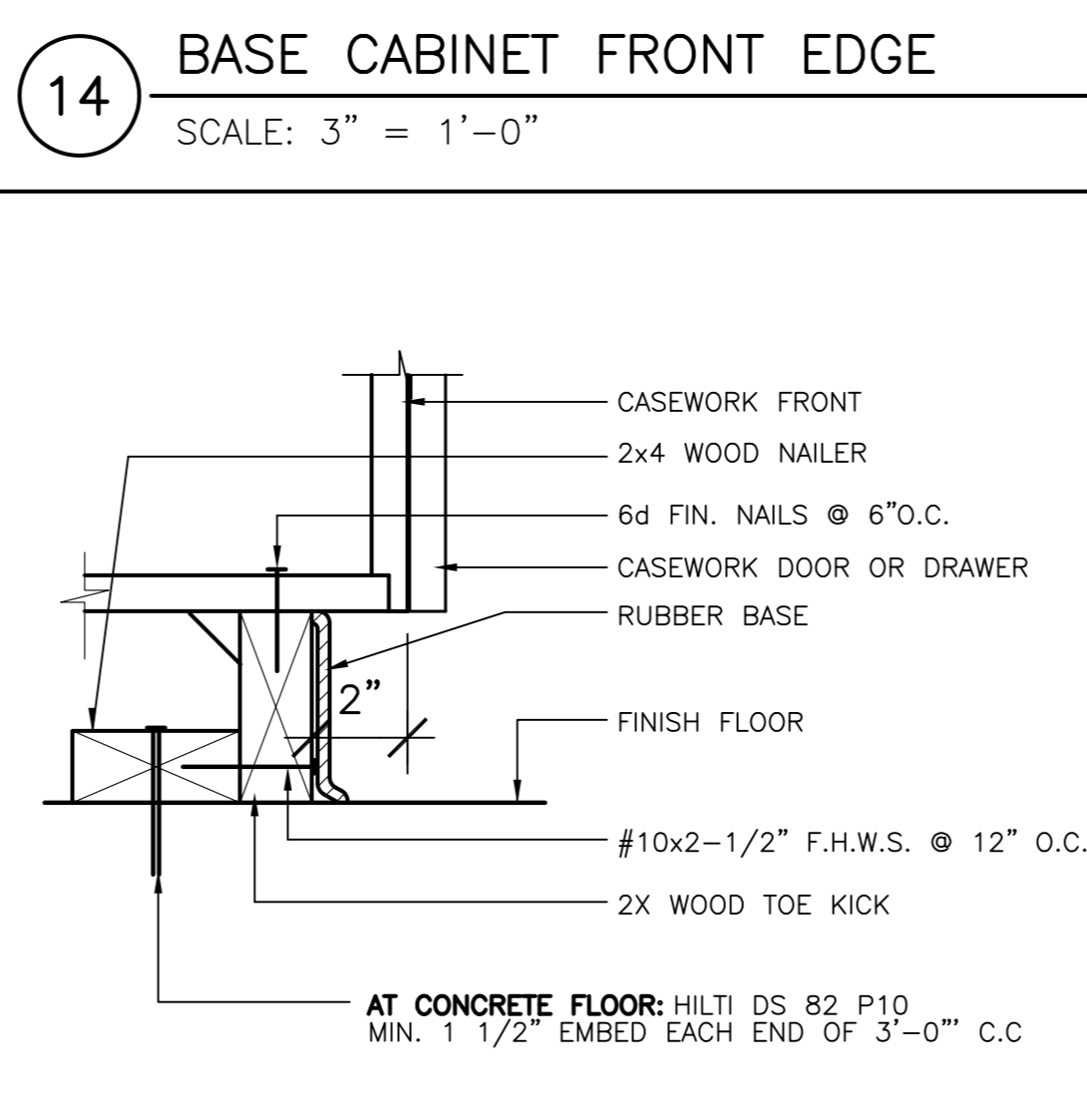

13 BASE CABINET ANCHOR
SCALE: 3" = 1'-0"

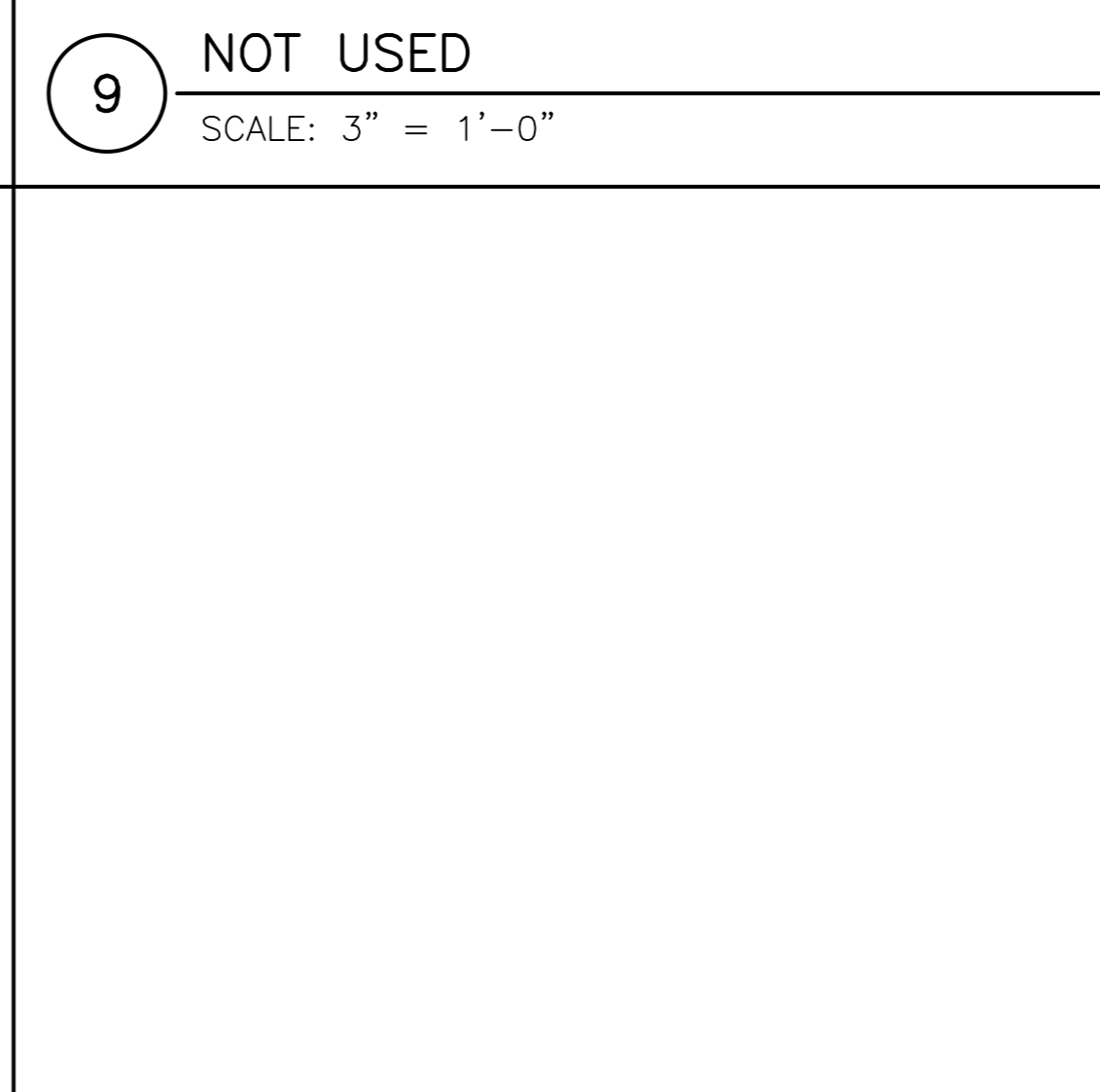

8 NOT USED
SCALE: 3" = 1'-0"

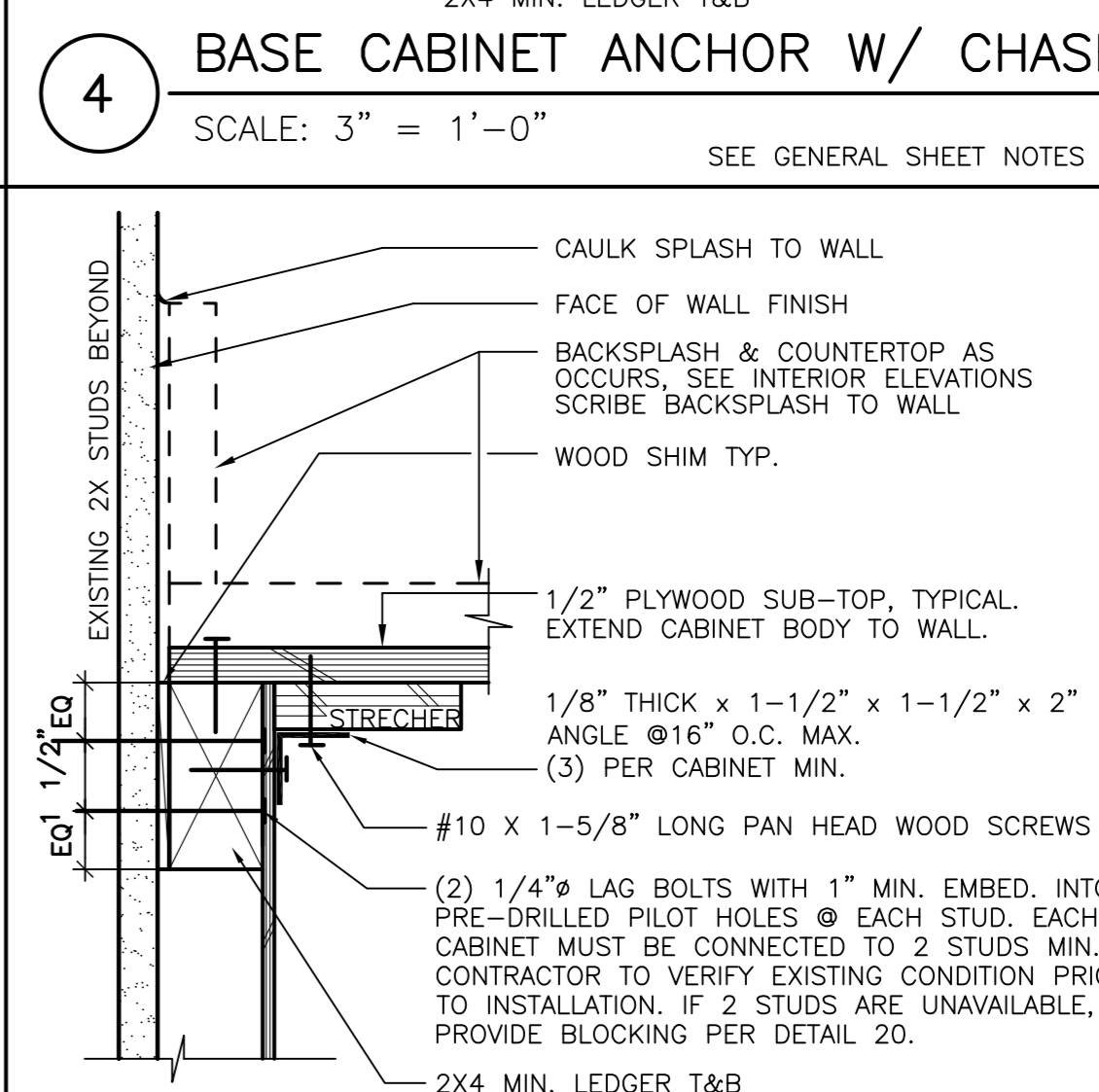

3 BASE CABINET ANCHOR W/O CHASE
SCALE: 3" = 1'-0" SEE GENERAL SHEET NOTES

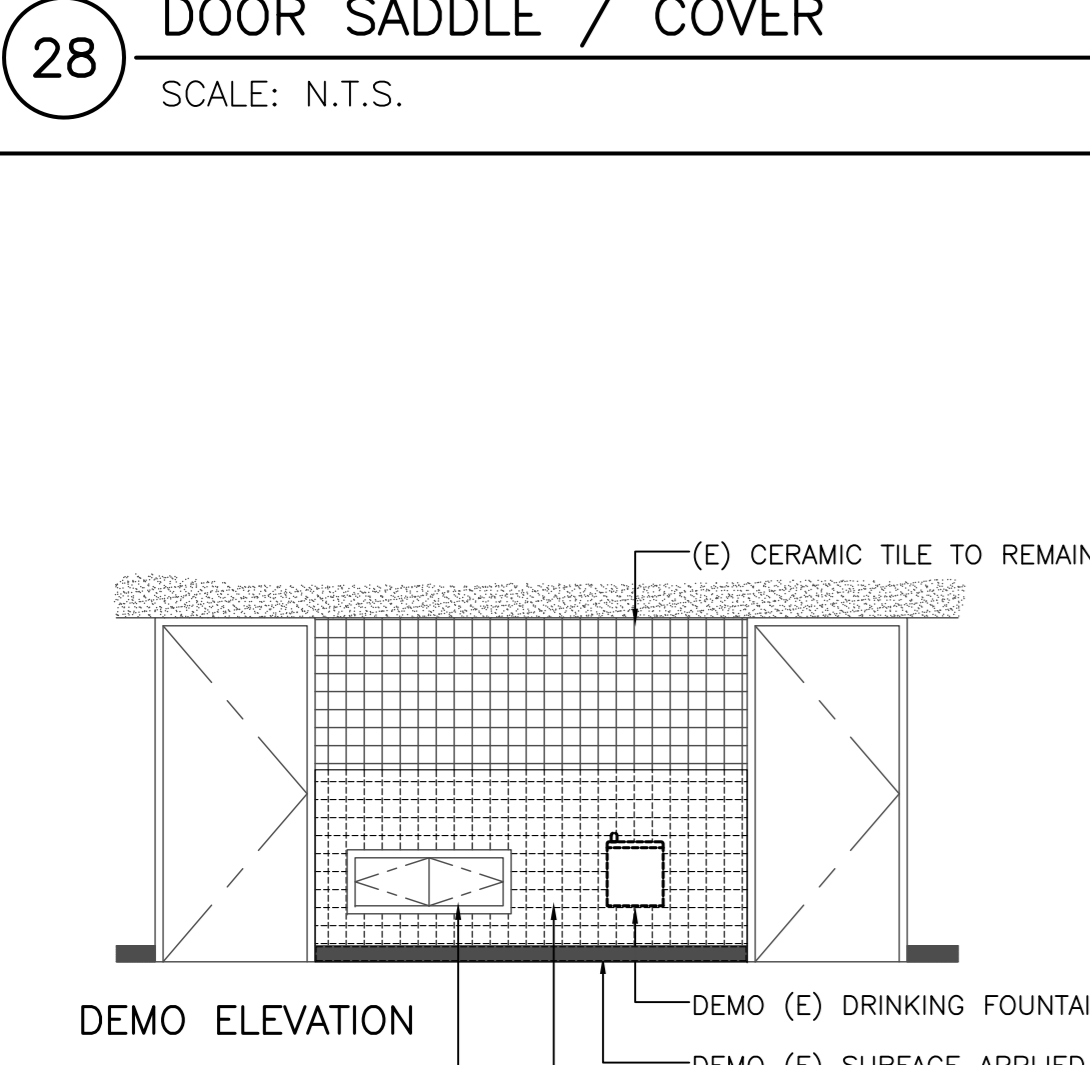

26 DRINKING FOUNTAIN REPLACEMENT
SCALE: N.T.S.

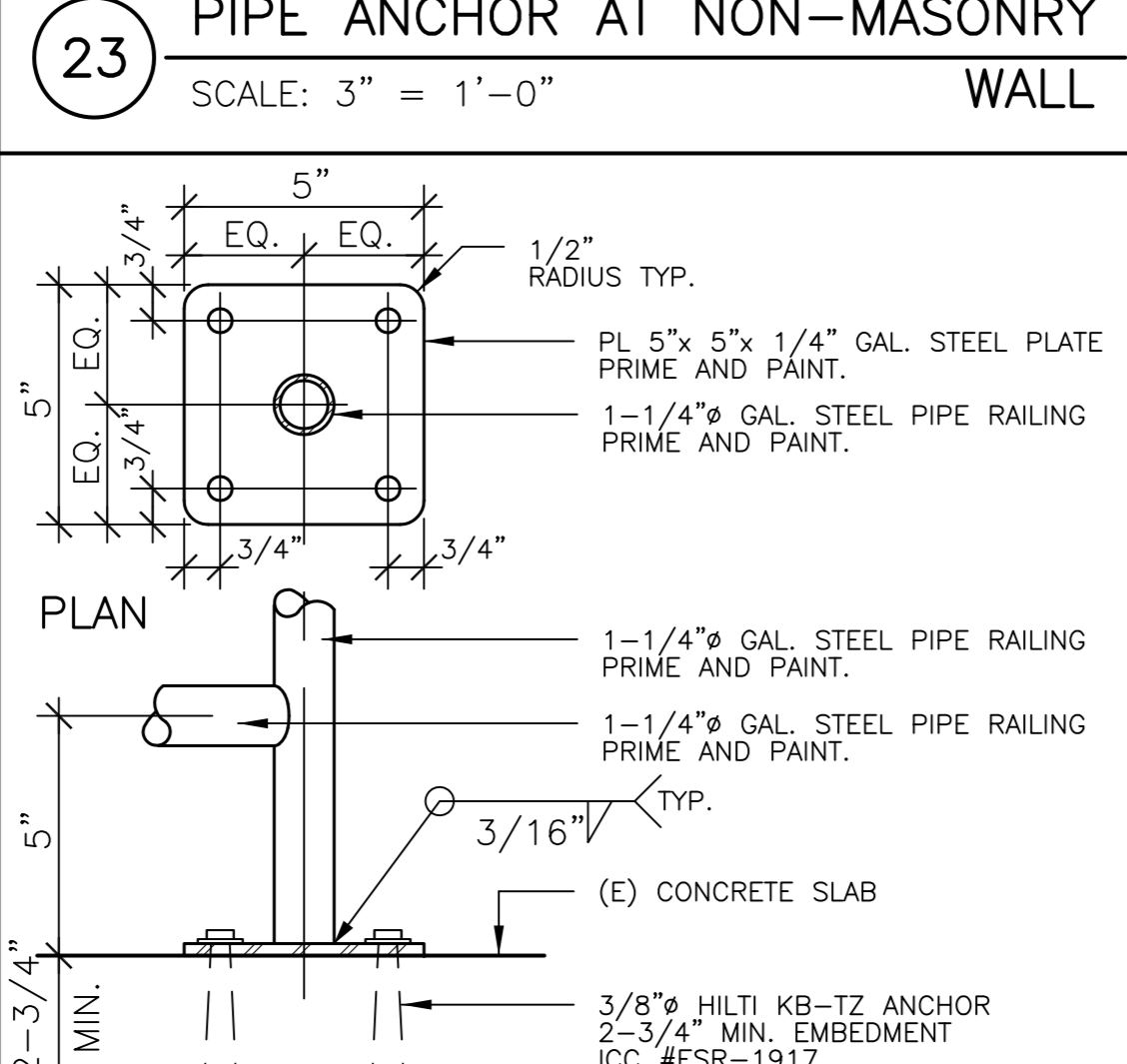

22 PIPE ANCHOR AT SLAB
SCALE: 3" = 1'-0"

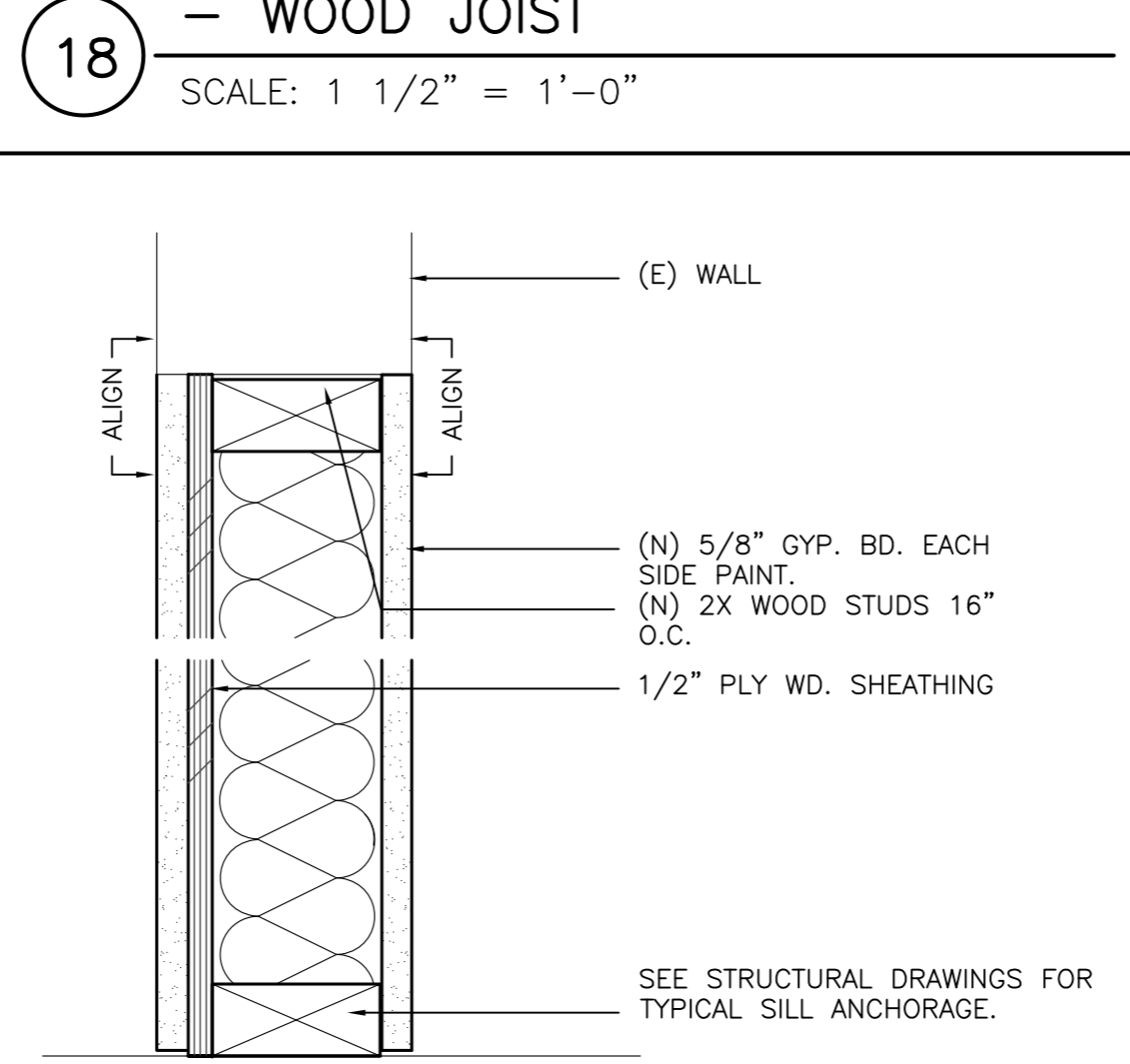

17 INTERIOR DOOR INFILL
SCALE: 3" = 1'-0"

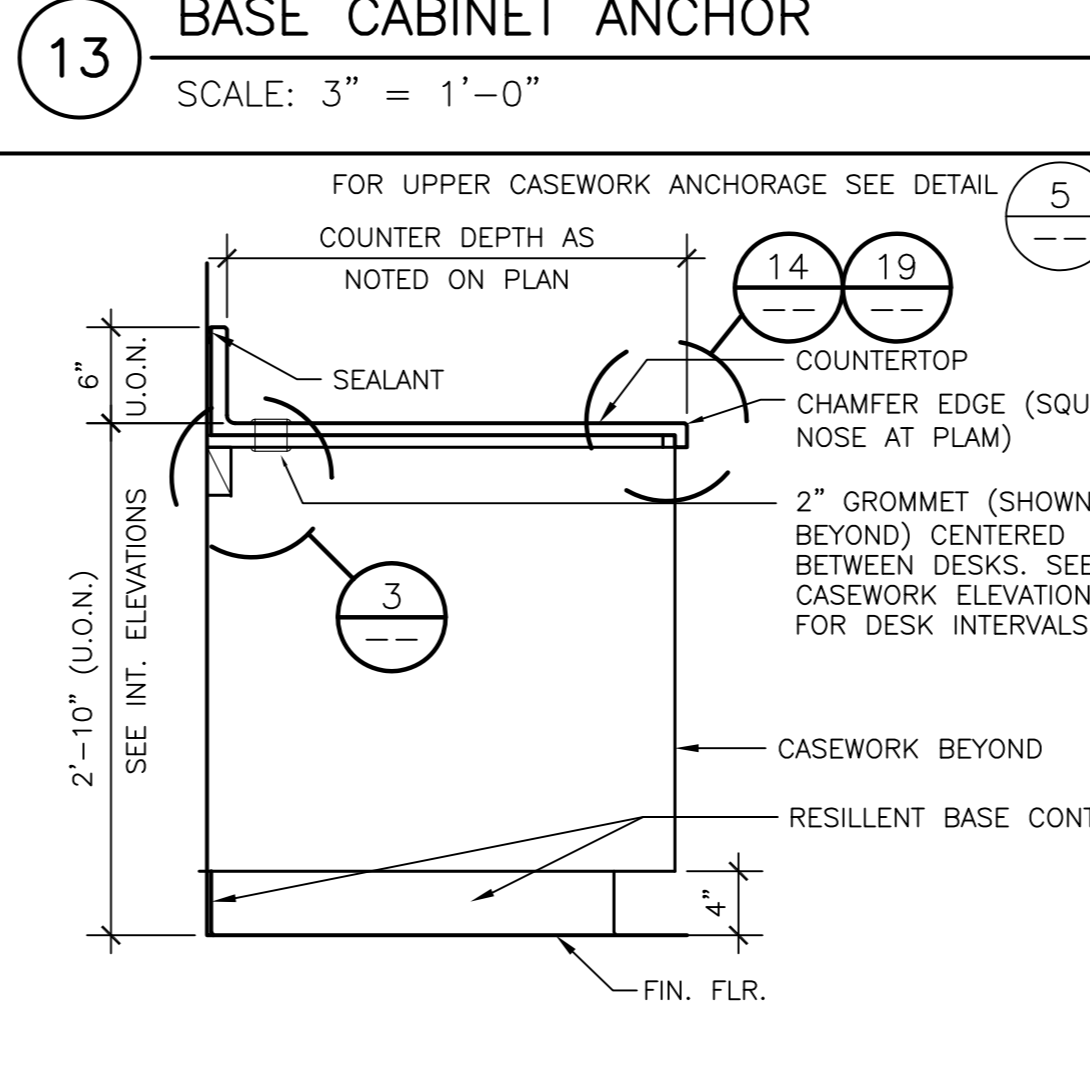

12 COMPUTER COUNTER TOP
SCALE: 1" = 1'-0"

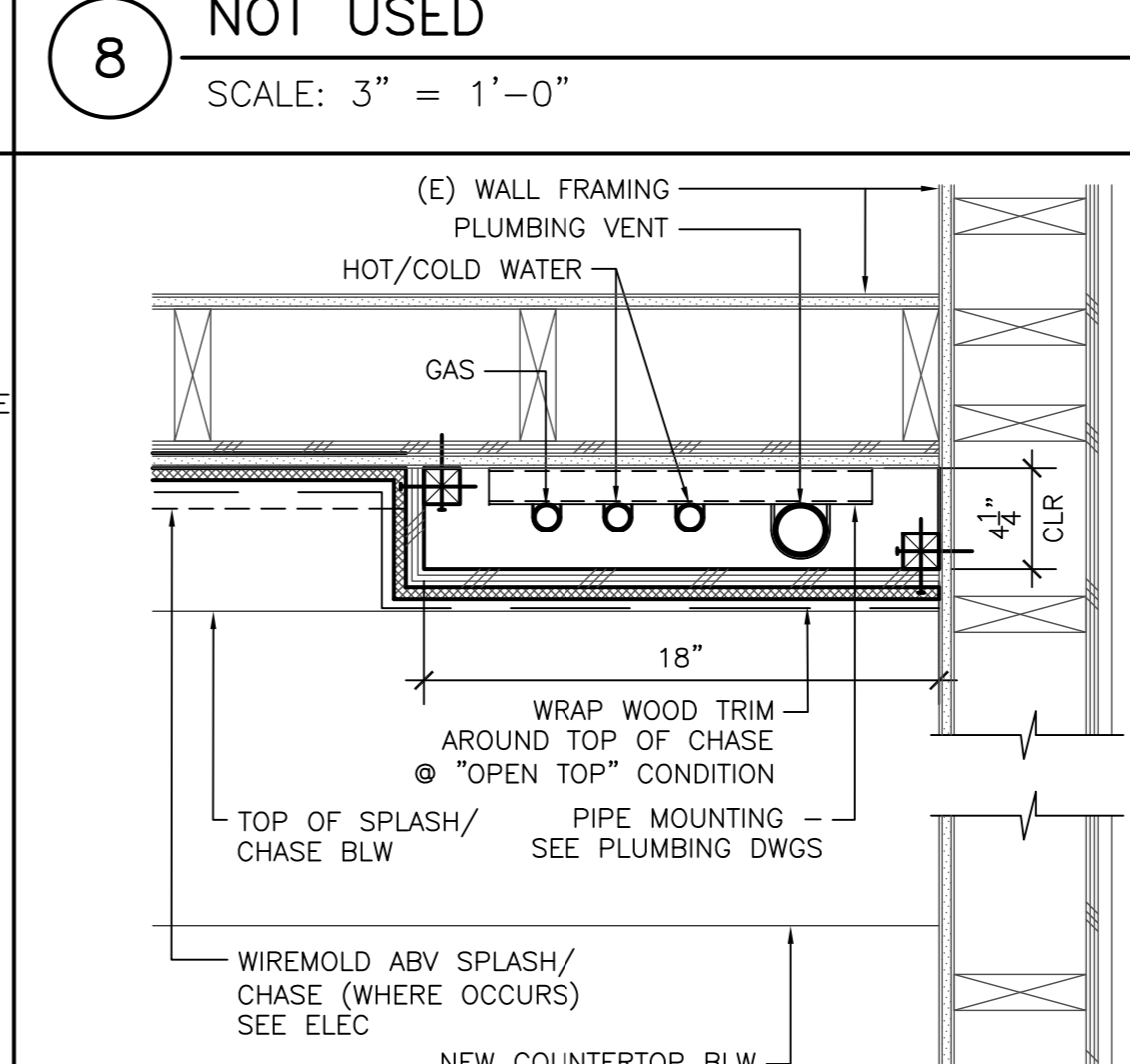

7 UTIL. CHASE TYPE 'B'
SCALE: 1 1/2" = 1'-0"

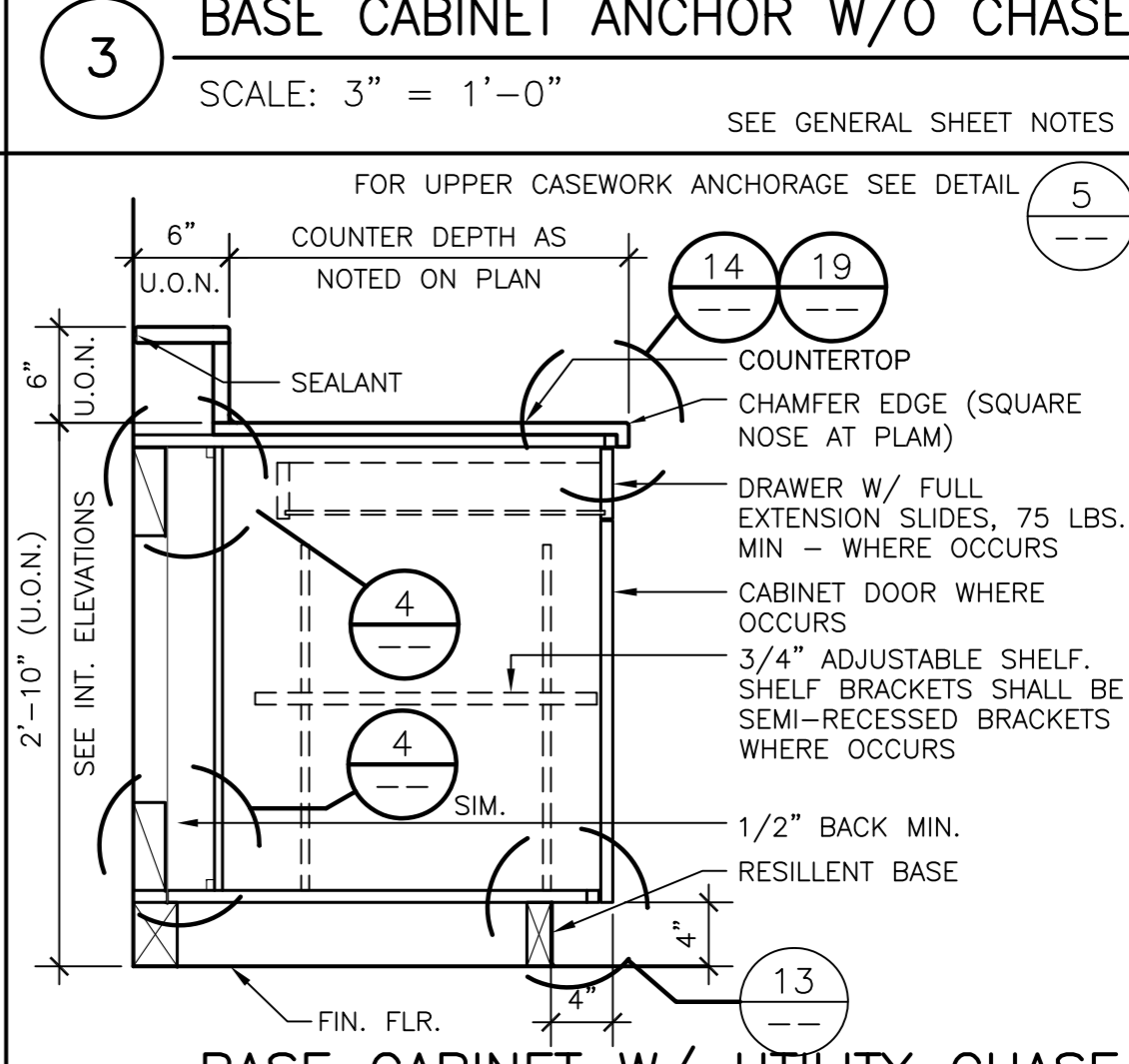

2 BASE CABINET W/ UTILITY CHASE A PART OF COUNTER TOP
SCALE: 1" = 1'-0" @ (E) WALL

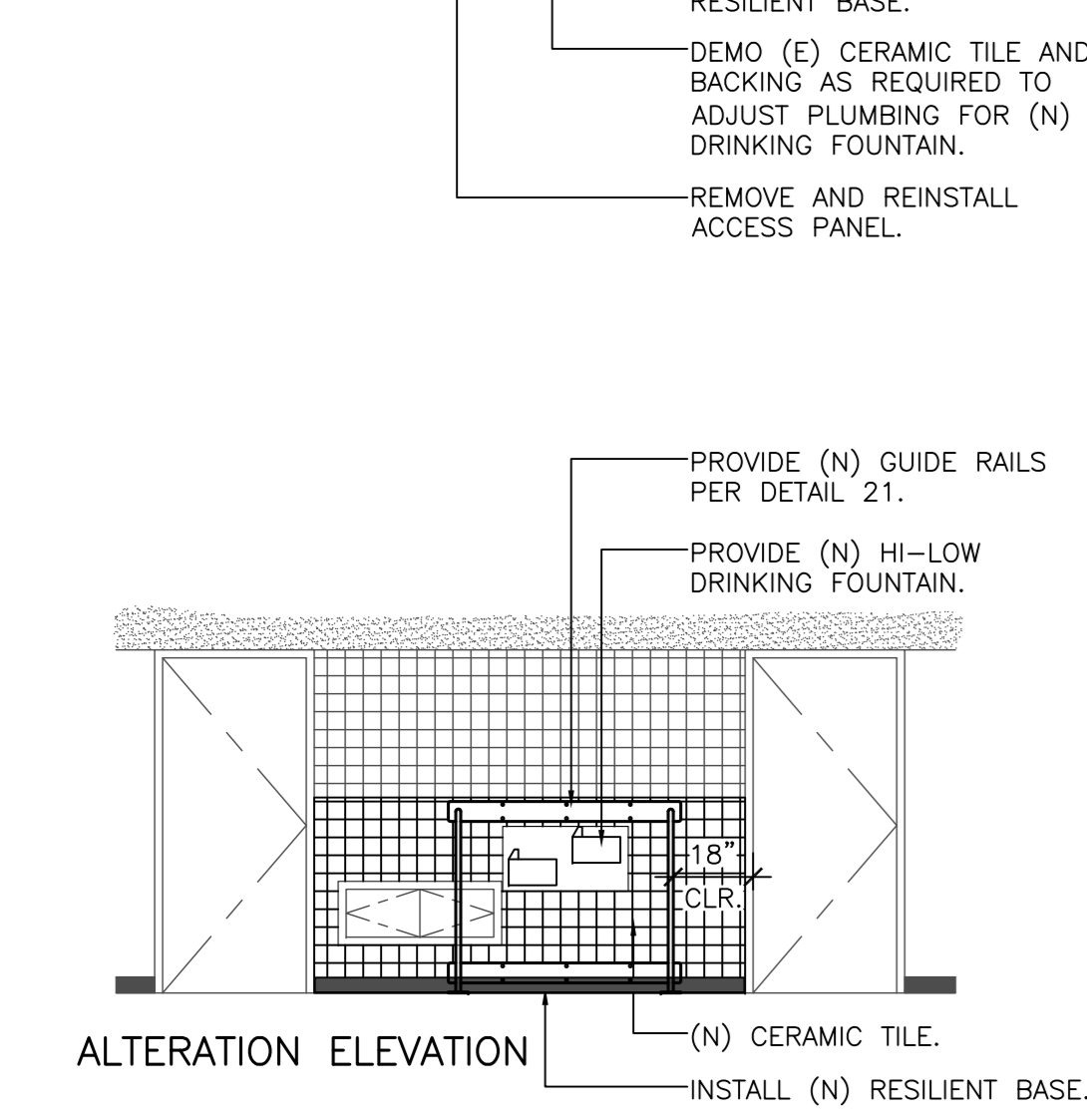

21 PIPE BARRIER AT D.F.
SCALE: N.T.S.

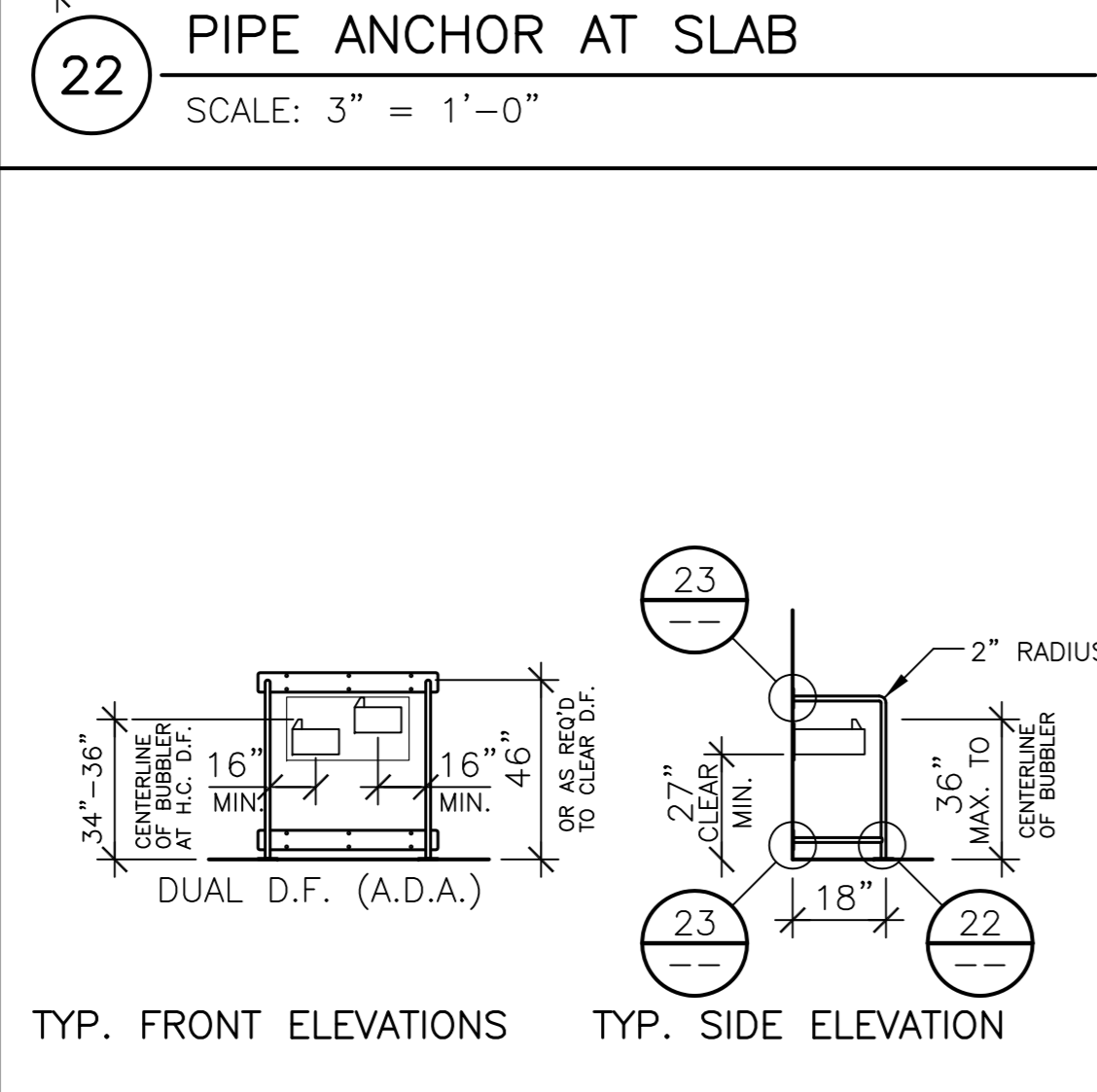

16 SINK FILLER PANEL
SCALE: N.T.S.

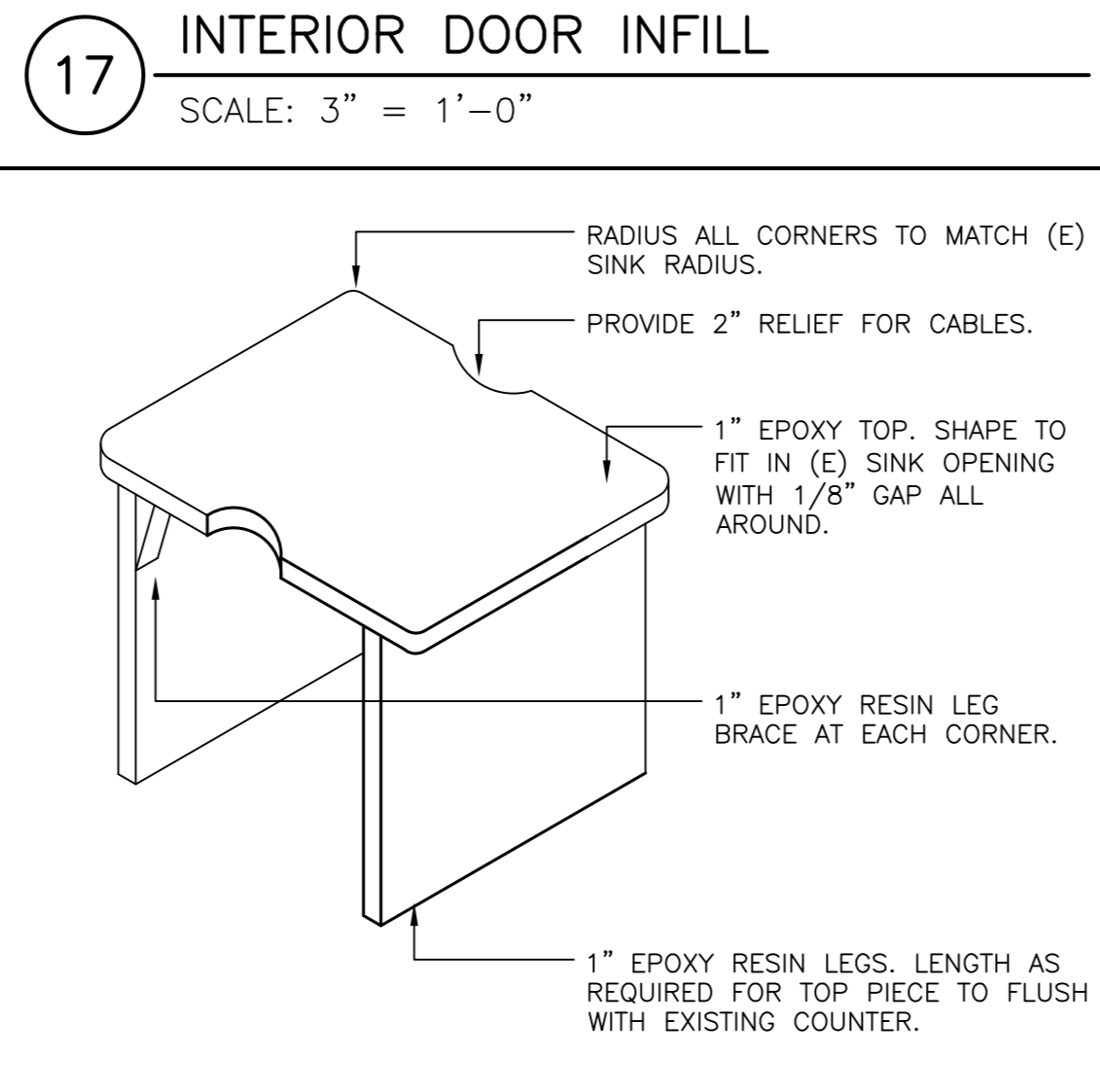

11 SHELF SAFETY LIP
SCALE: 6" = 1'-0"

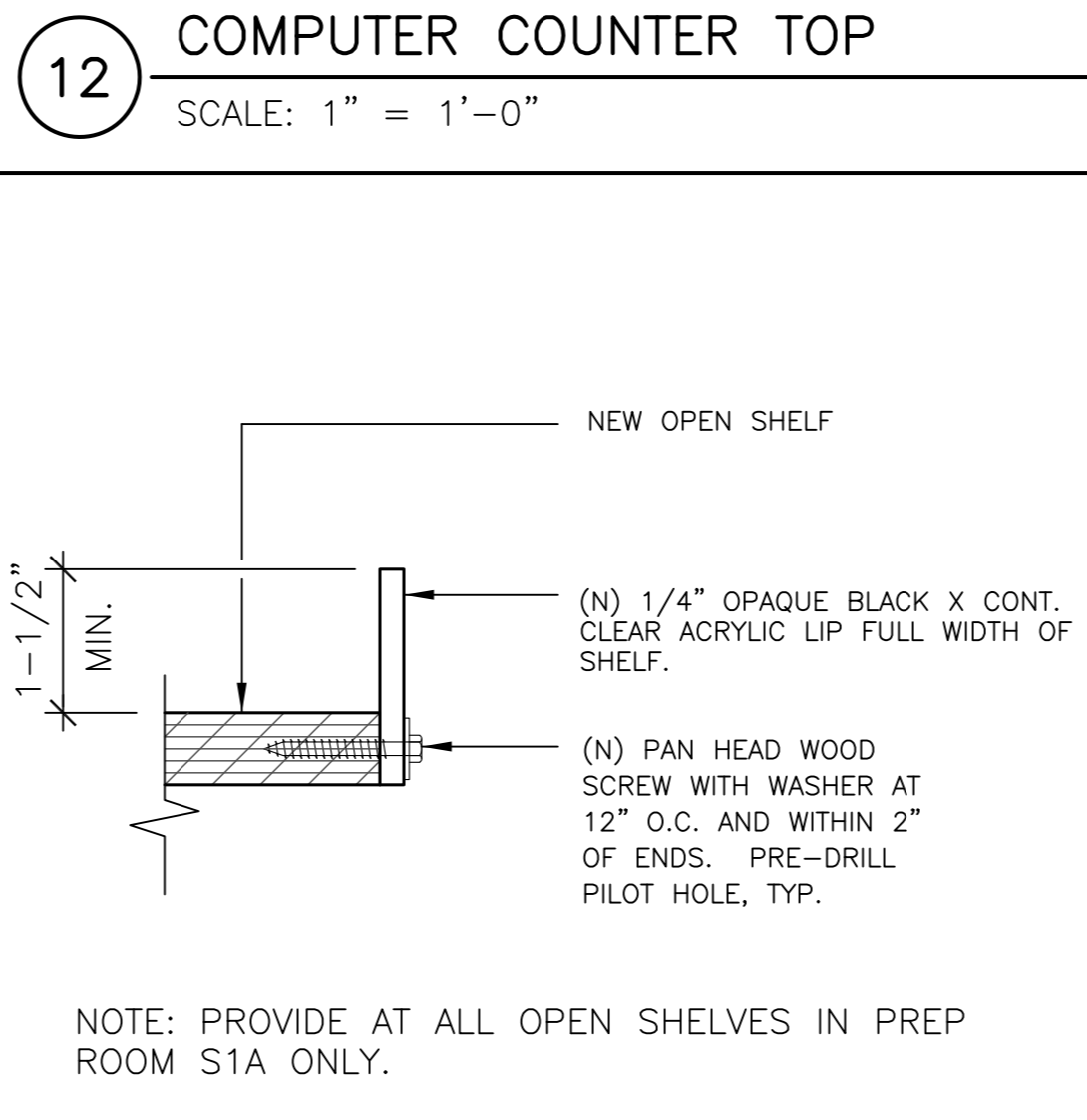

6 UTIL. CHASE TYPE 'A'
SCALE: 1 1/2" = 1'-0"

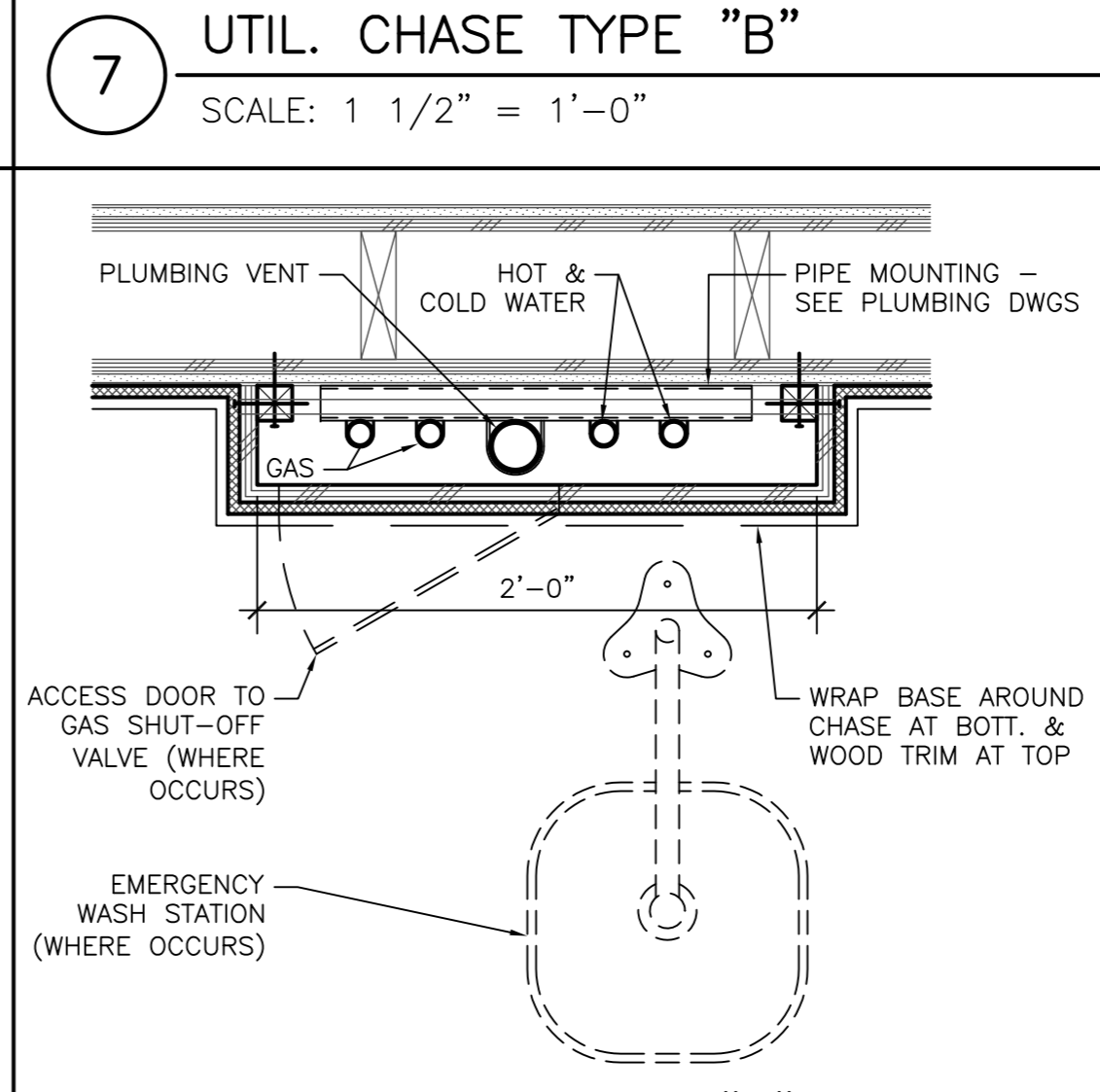

1 BASE CABINET W/O UTILITY CHASE
SCALE: 1" = 1'-0" @ (E) WALL

Mt. Diablo High School
Building S - Science Lab Modernization
 2460 Grant Street
 Concord, California 94520
Mt. Diablo Unified School District

MDUSD
 MOUNTAIN DIABLO UNIFIED SCHOOL DISTRICT

FILE NO. XX-XX
 IDENTIFICATION STAMP
 DIV. OF THE STATE ARCHITECT
 OFFICE OF REGULATION SERVICES
 APPLICATION NO. 01-
 AC. FLS. SS
 DATE _____

DIVISION OF THE STATE ARCHITECT
 revision date: _____ by: _____

CONSULTANT
nacht&lewis
 600 Q Street, Suite 100
 Sacramento, CA 95811
 www.nachtlewis.com
 916.329.4000

ARCHITECT
REVISIONS

NO.	DESCRIPTION	DATE	REV'D

DATE February 19, 2012
 JOB NO. Y1211.00
SHEET TITLE
Details
SHEET NO.
A8.0
 SHEET ___ OF ___ TOTAL
DSA SUBMITTAL SET

ONE AND ONE-HALF INCH = ONE FOOT
 ONE INCH = ONE FOOT
 THREE-QUARTERS INCH = ONE FOOT
 ONE-HALF INCH = ONE FOOT
 ONE-QUARTER INCH = ONE FOOT
 ONE-EIGHTH INCH = ONE FOOT
 ONE-SIXTEENTH INCH = ONE FOOT
 ONE INCH = TWENTY FEET

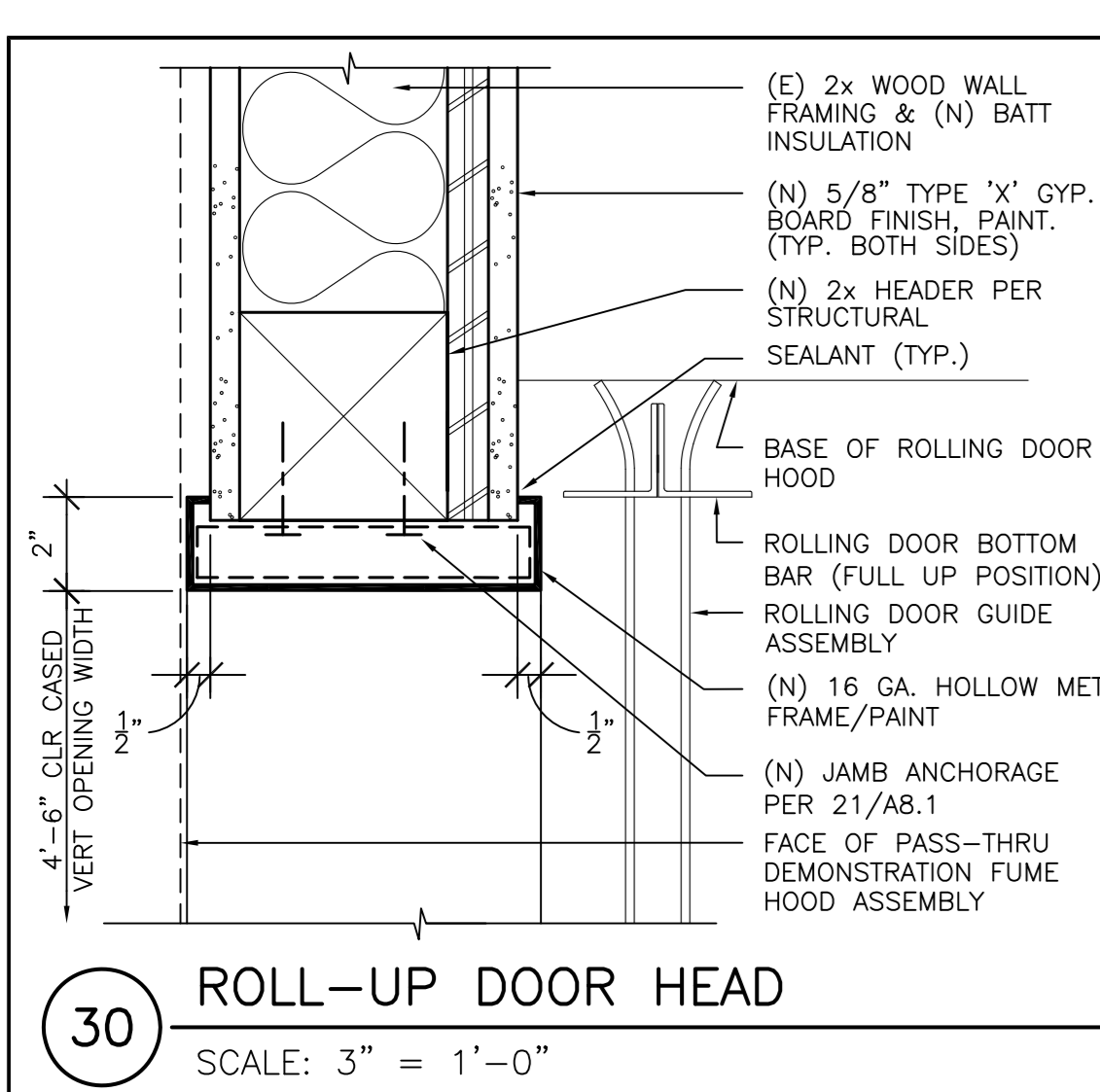

30 ROLL-UP DOOR HEAD
 SCALE: 3" = 1'-0"

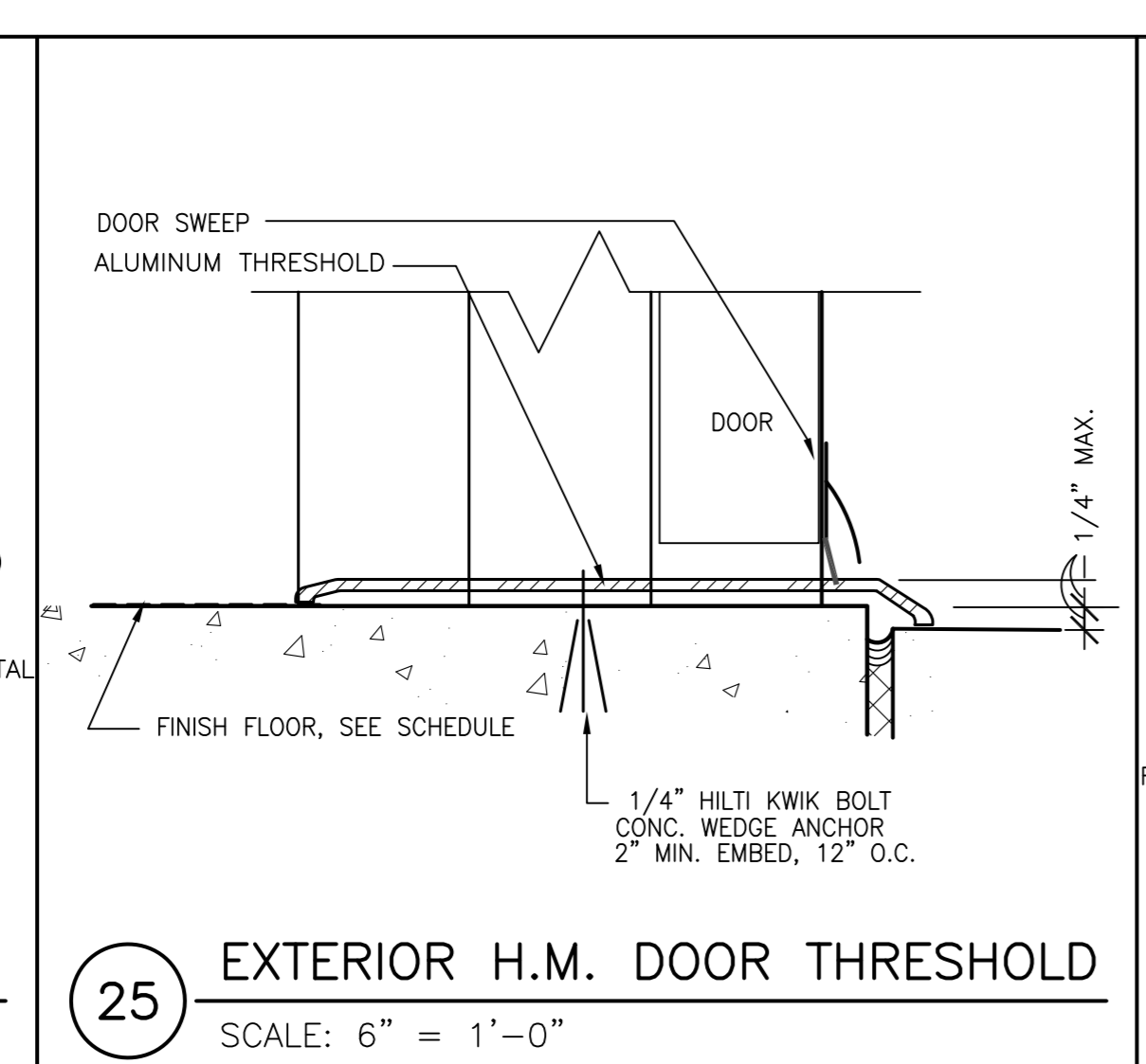

25 EXTERIOR H.M. DOOR THRESHOLD
 SCALE: 6" = 1'-0"

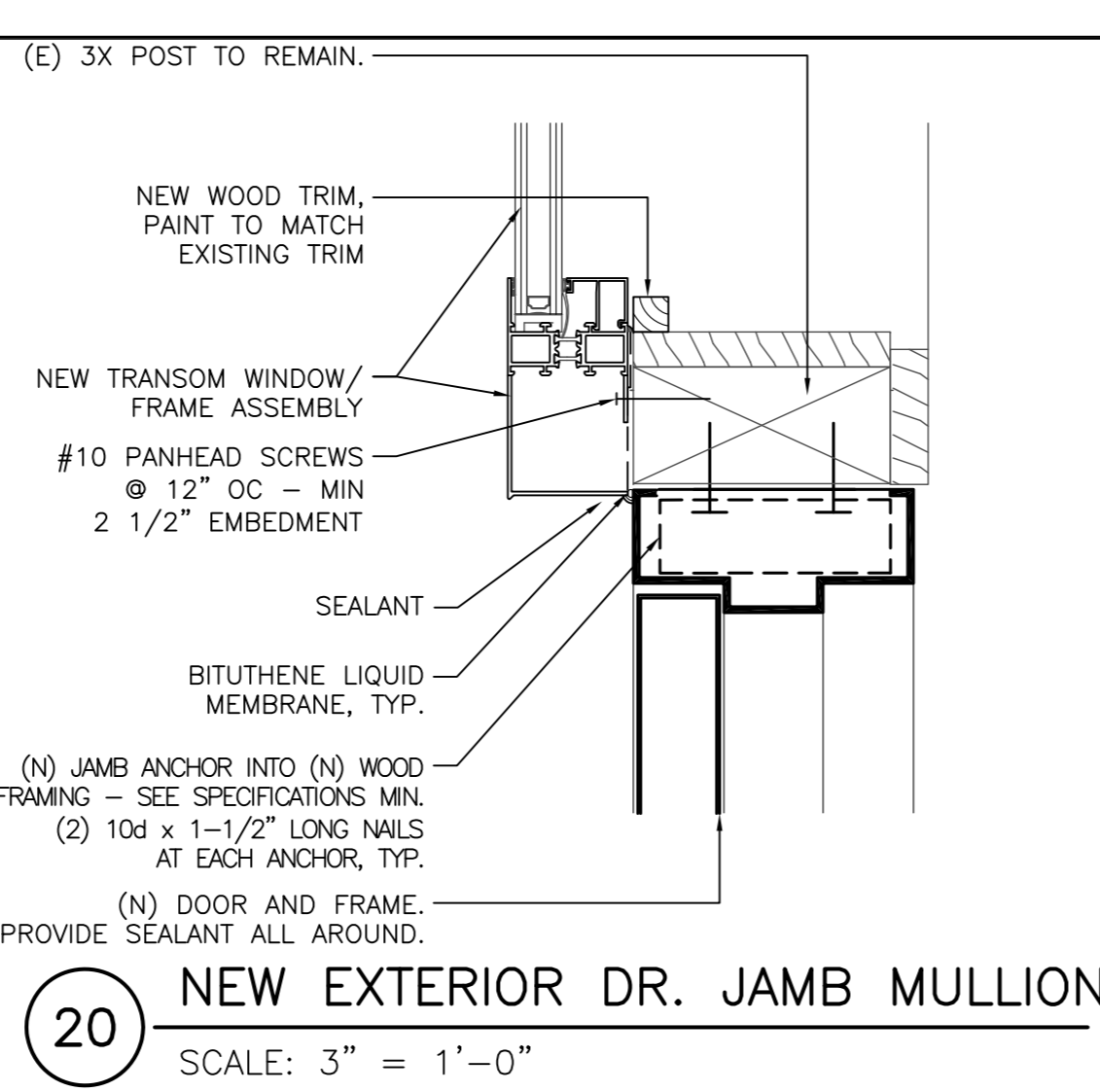

20 NEW EXTERIOR DR. JAMB MULLION
 SCALE: 3" = 1'-0"

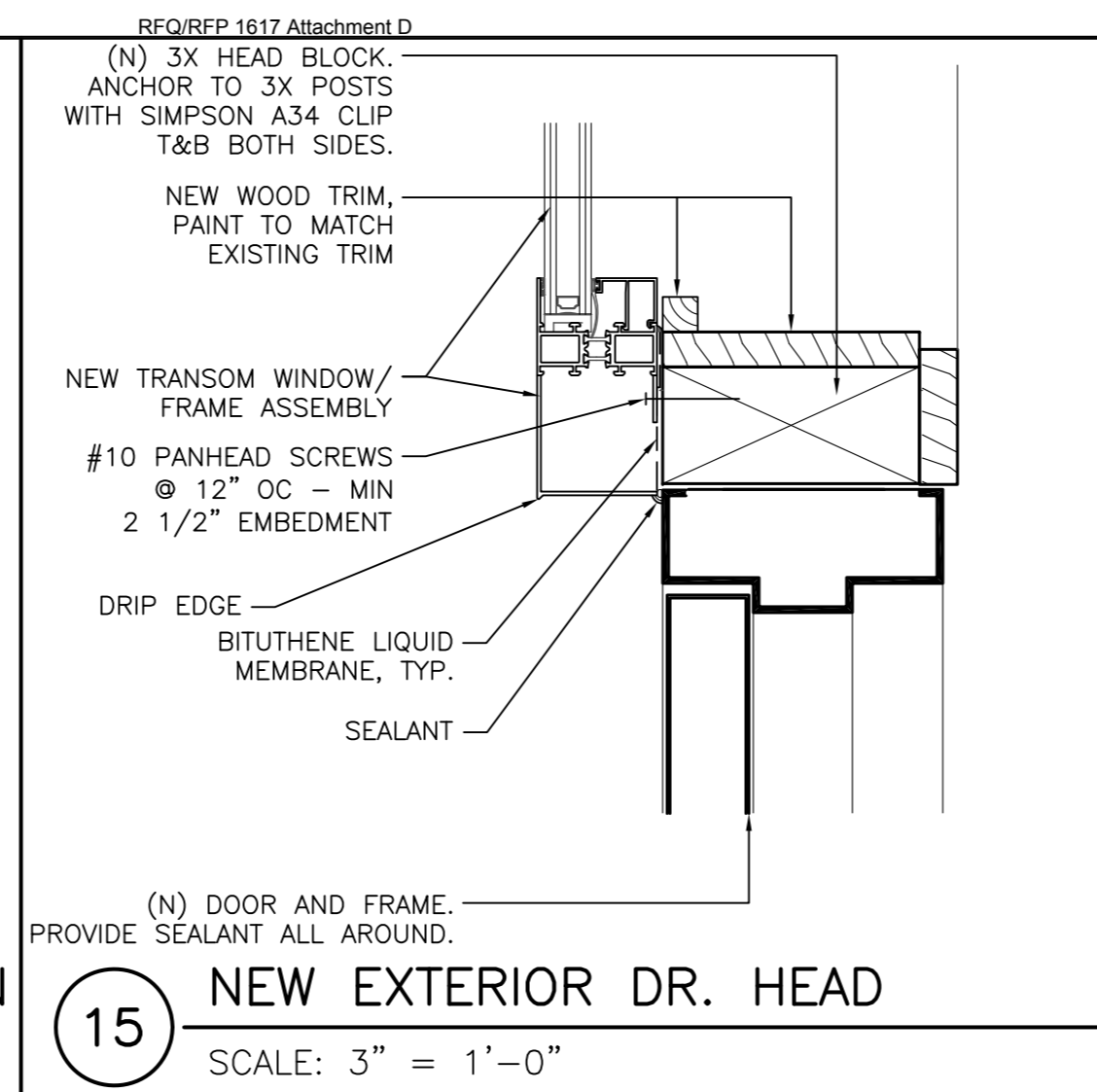

15 NEW EXTERIOR DR. HEAD
 SCALE: 3" = 1'-0"

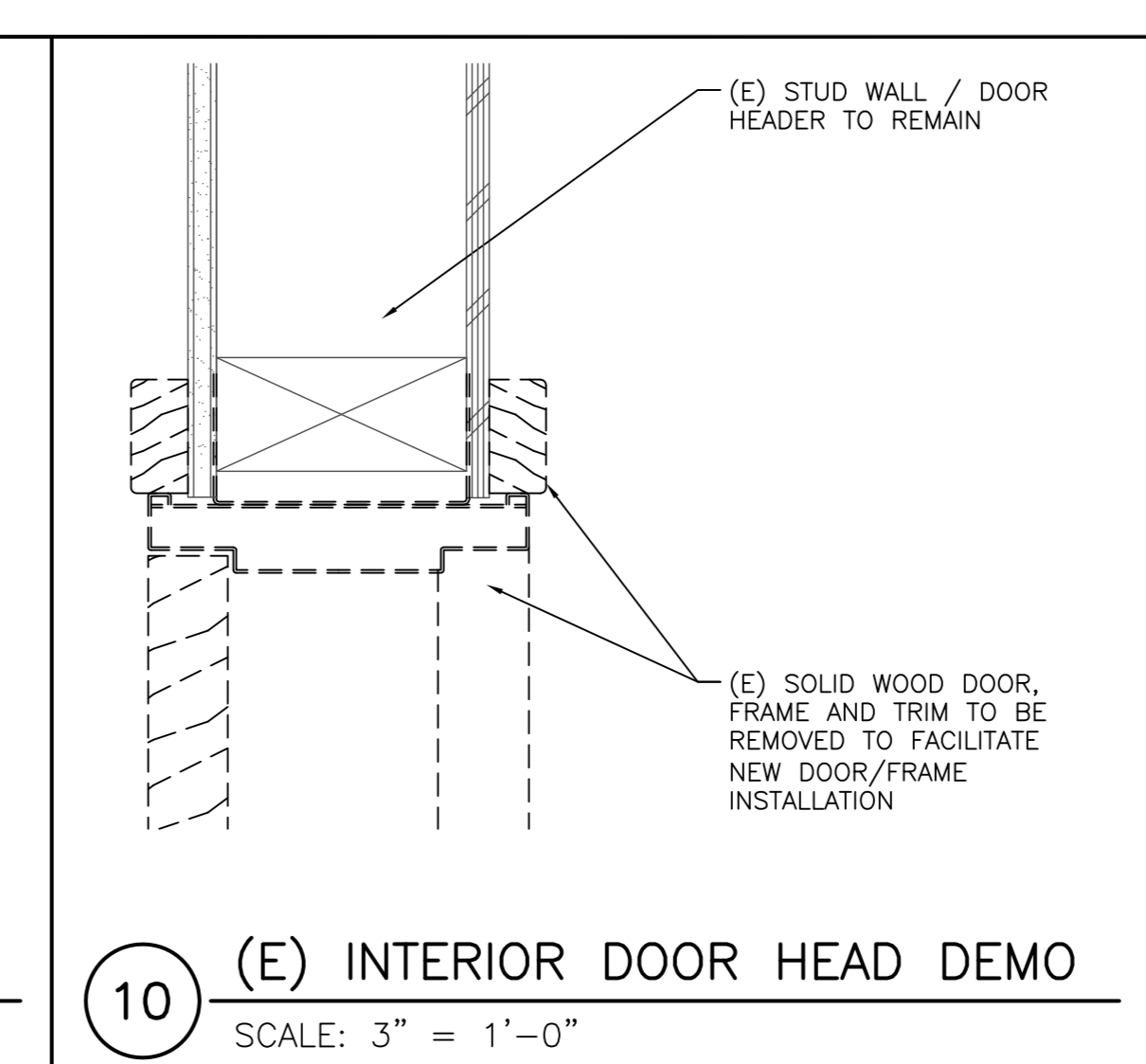

10 (E) INTERIOR DOOR HEAD DEMO
 SCALE: 3" = 1'-0"

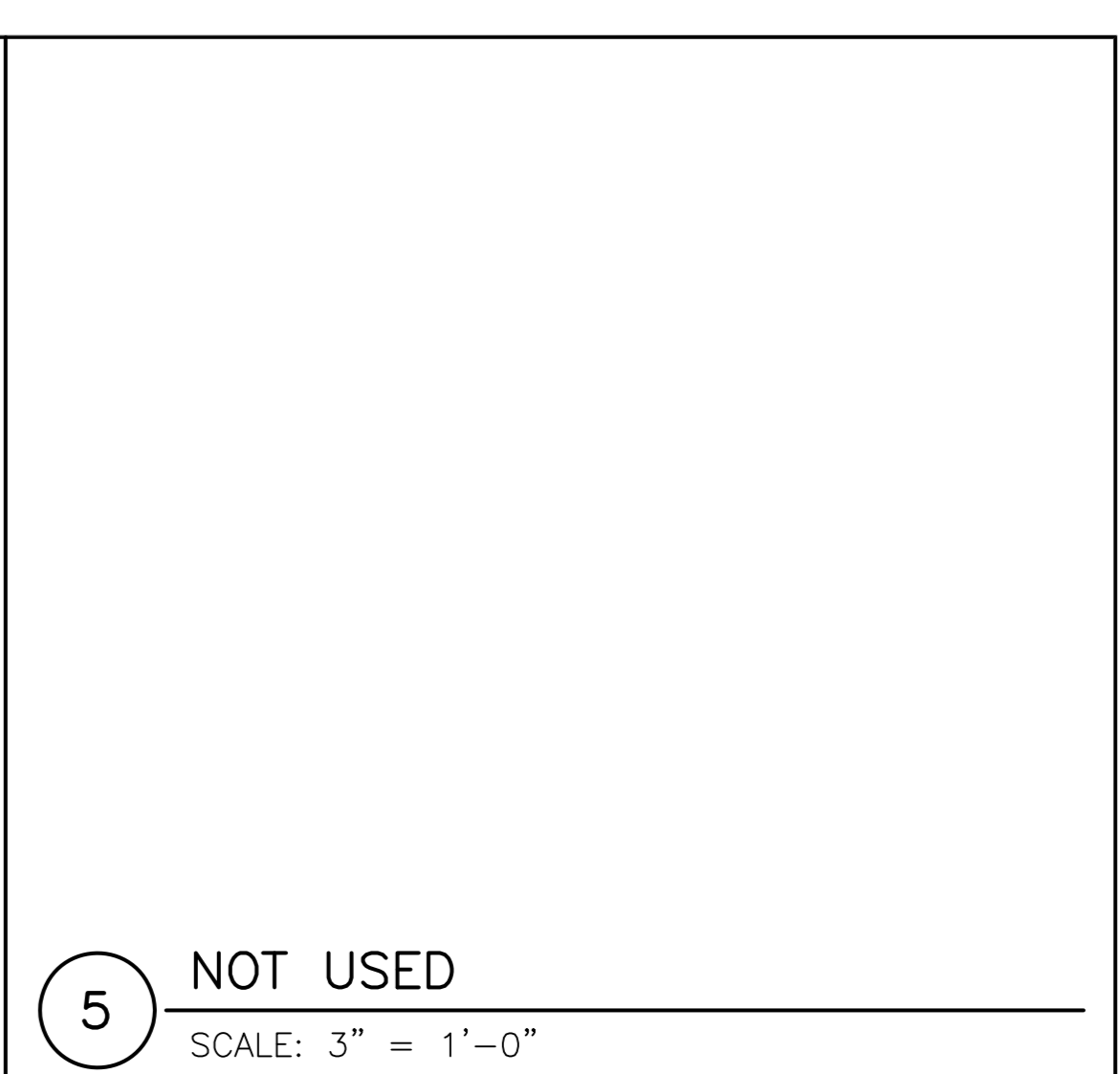

5 NOT USED
 SCALE: 3" = 1'-0"

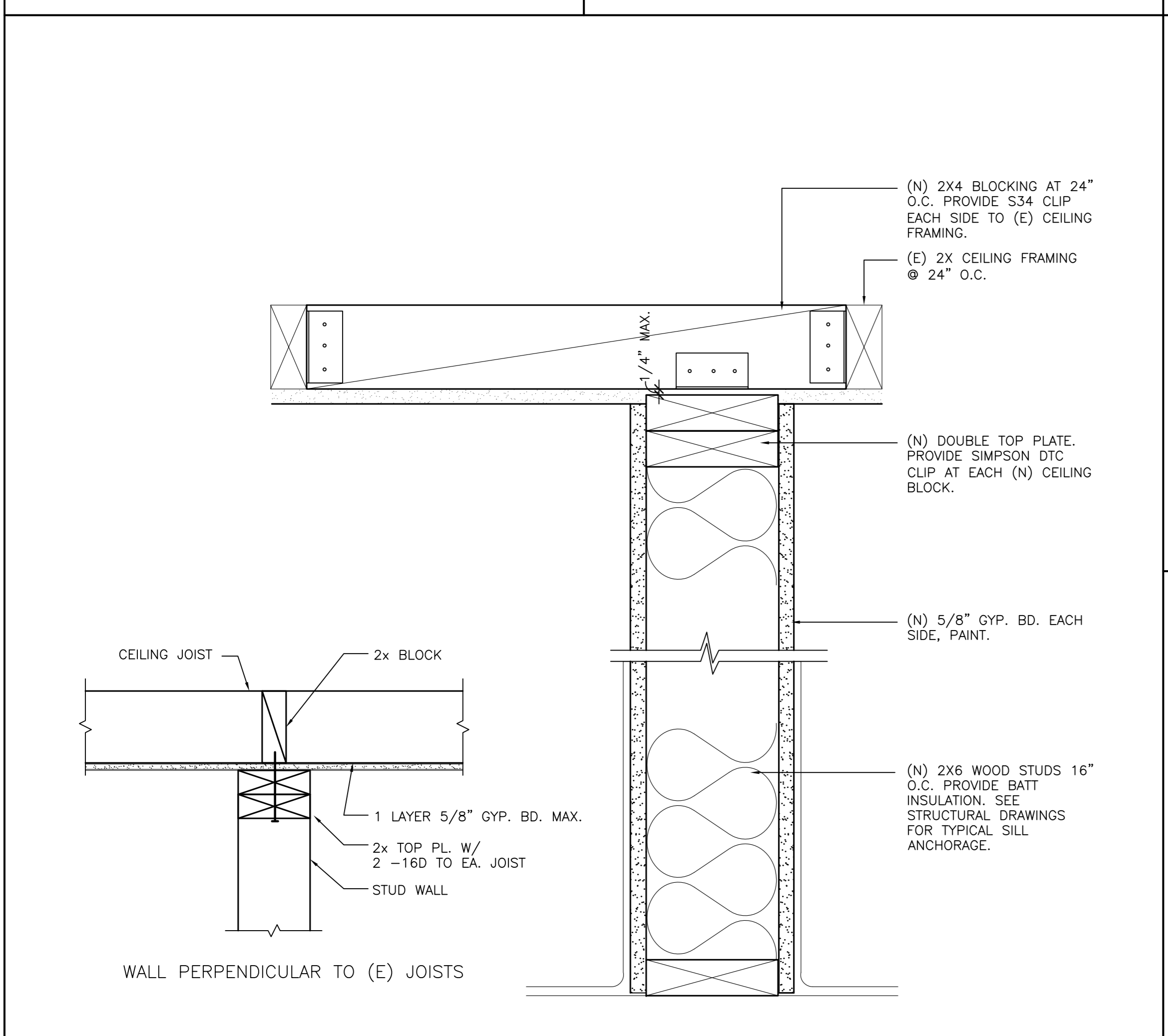

28 INTERIOR NON-BEARING WALL
 SCALE: 3" = 1'-0"



19 (E) DOOR HEAD DEMO
 SCALE: 3" = 1'-0"

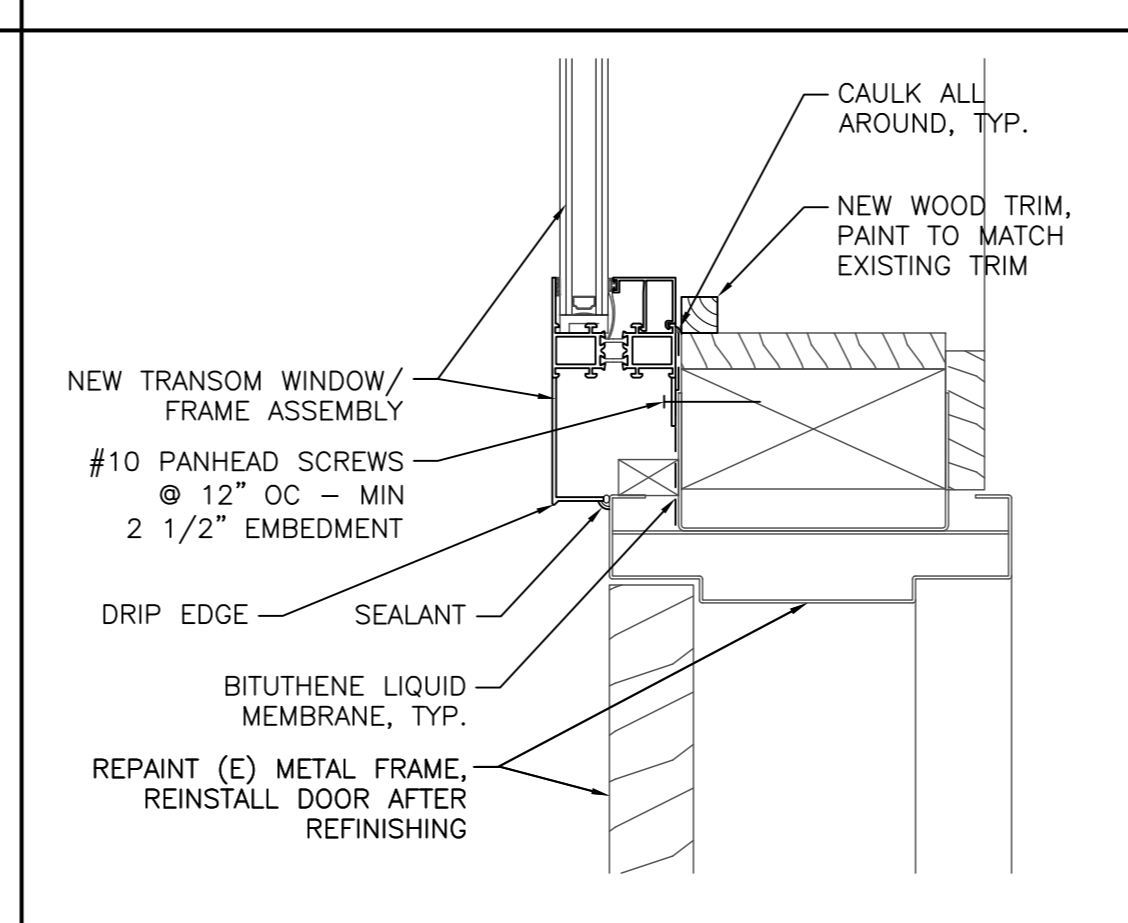

14 (E) DOOR HEAD ALTERATION
 SCALE: 3" = 1'-0"

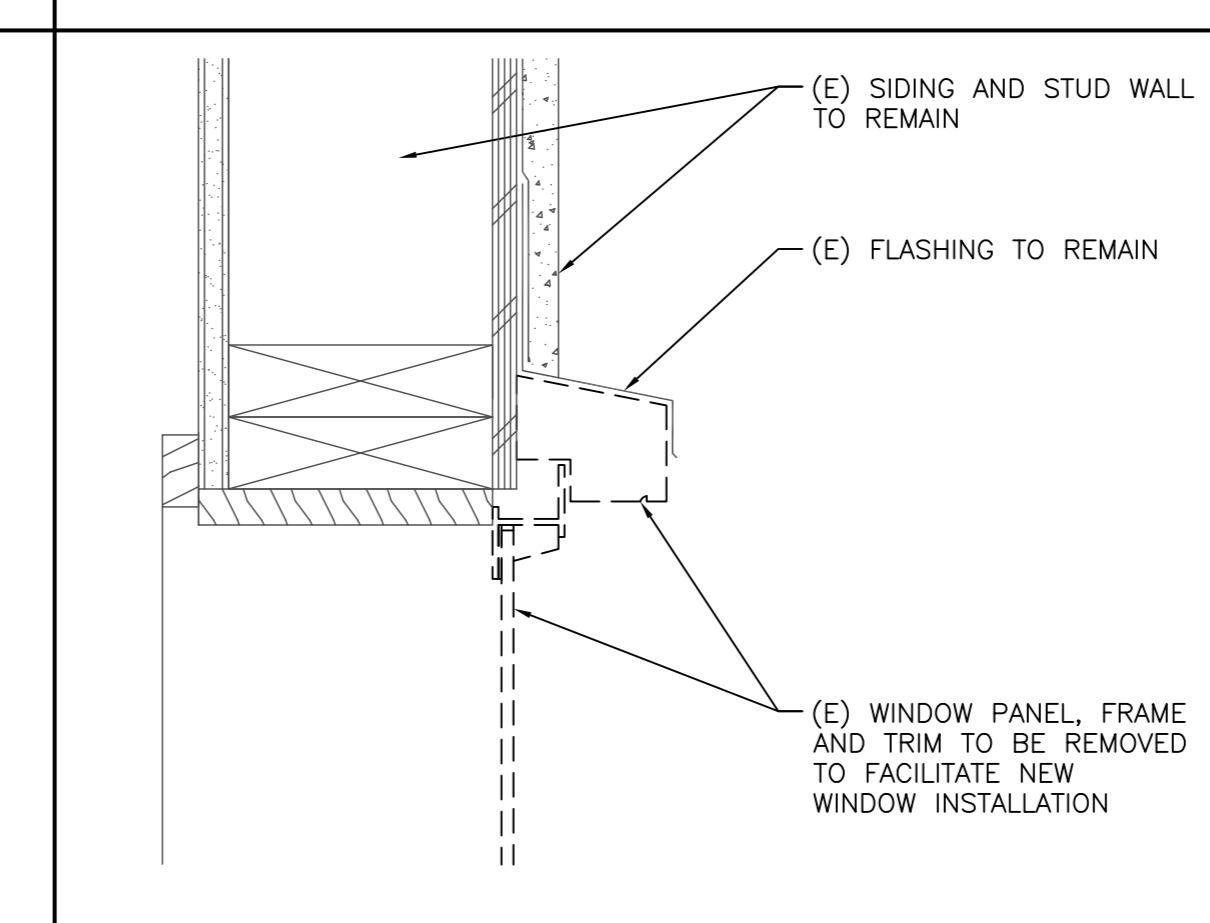

9 (E) WINDOW HEAD
 SCALE: 3" = 1'-0"

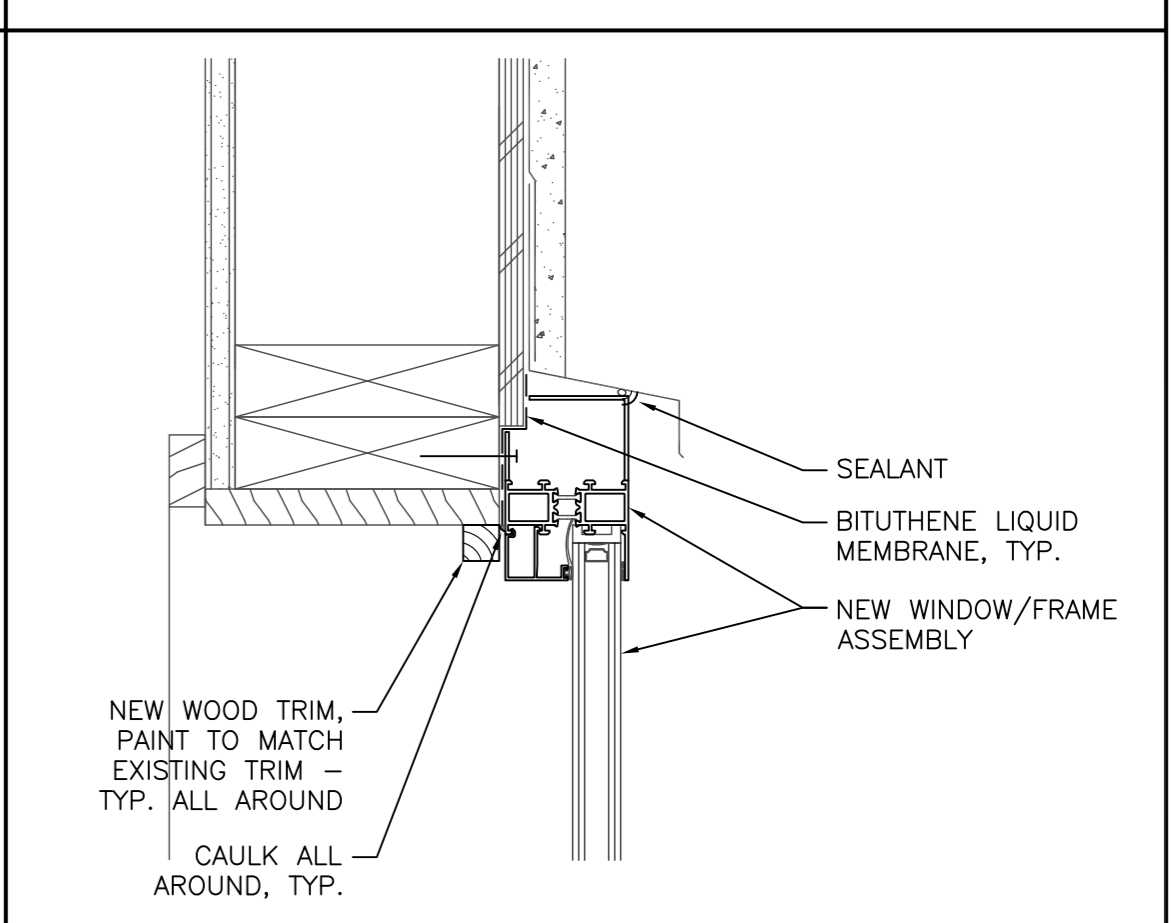

4 NEW WINDOW HEAD
 SCALE: 3" = 1'-0"

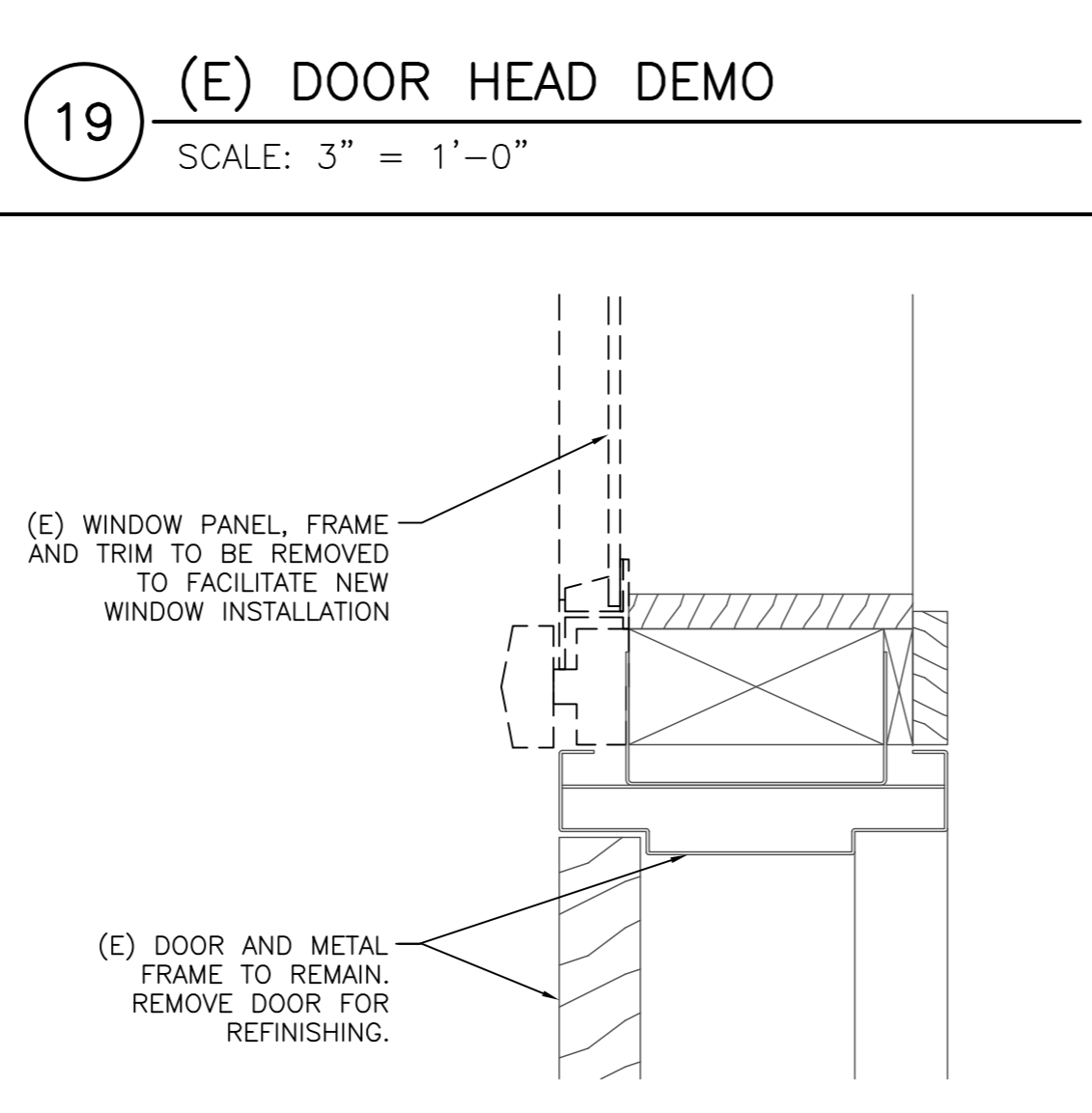

18 (E) DOOR JAMB DEMO
 SCALE: 3" = 1'-0"

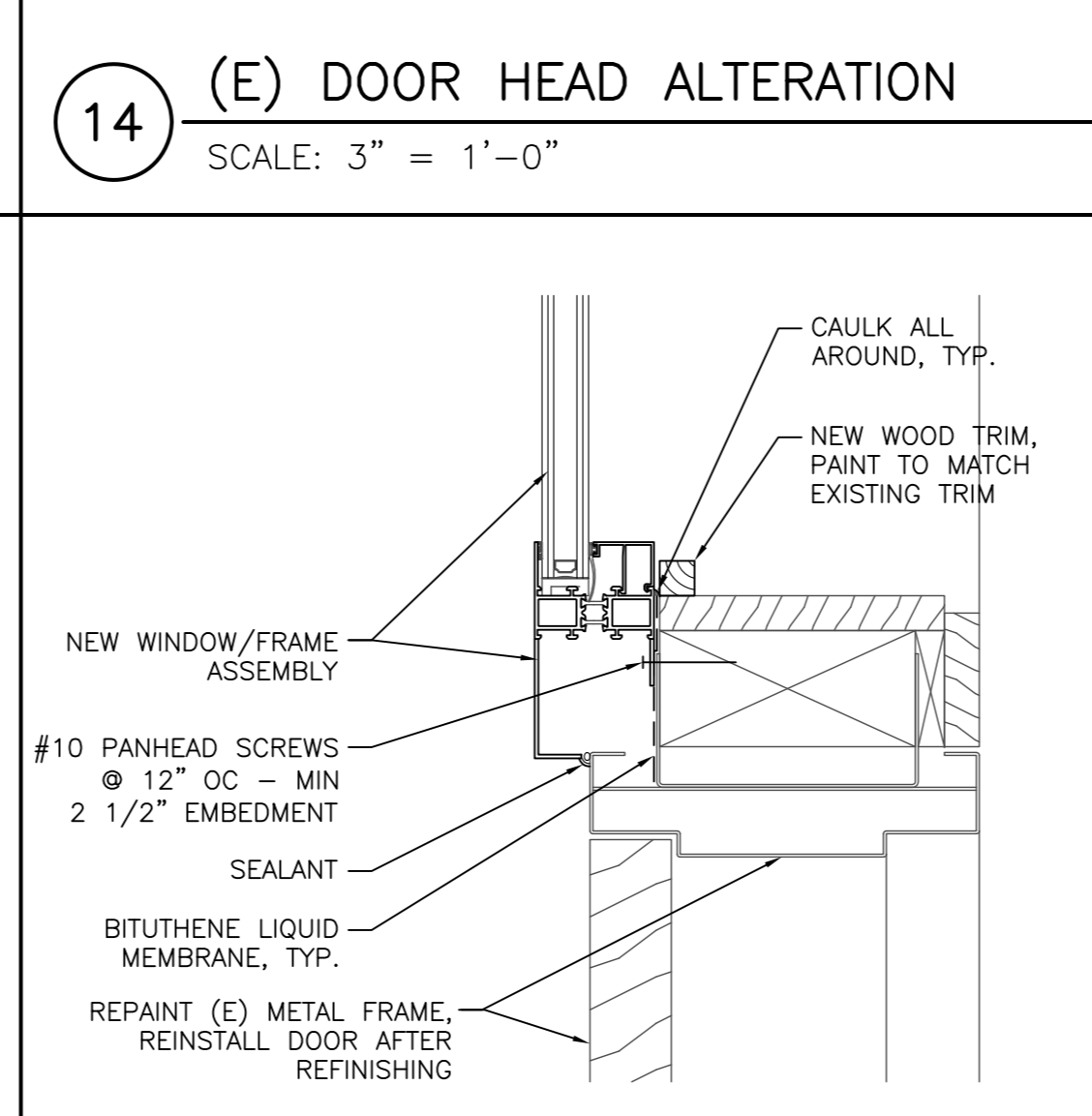

13 NEW DOOR JAMB
 SCALE: 3" = 1'-0"

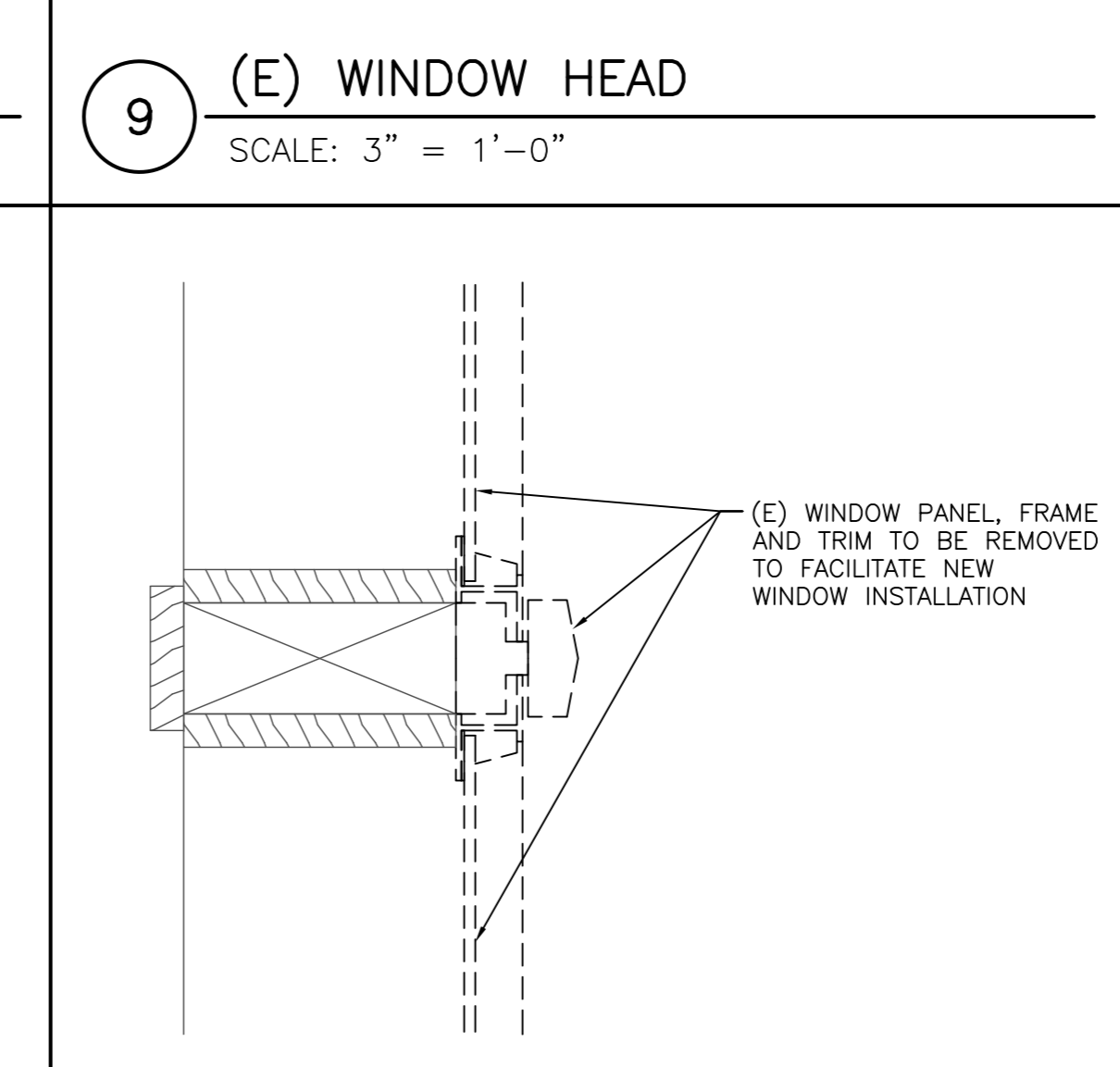

8 (E) WINDOW MULLION DEMO
 SCALE: 3" = 1'-0"

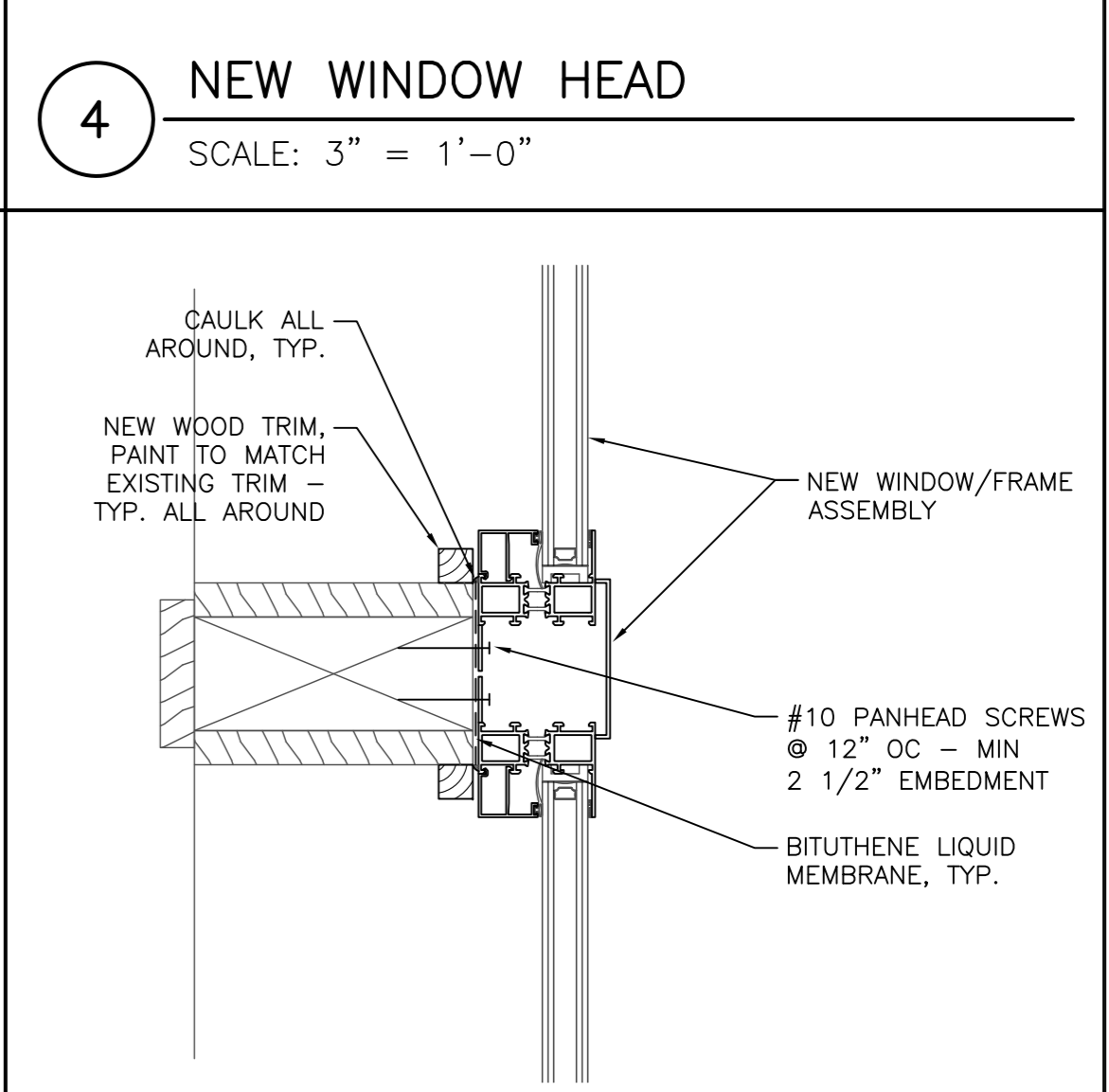

3 NEW WINDOW MULLION
 SCALE: 3" = 1'-0"

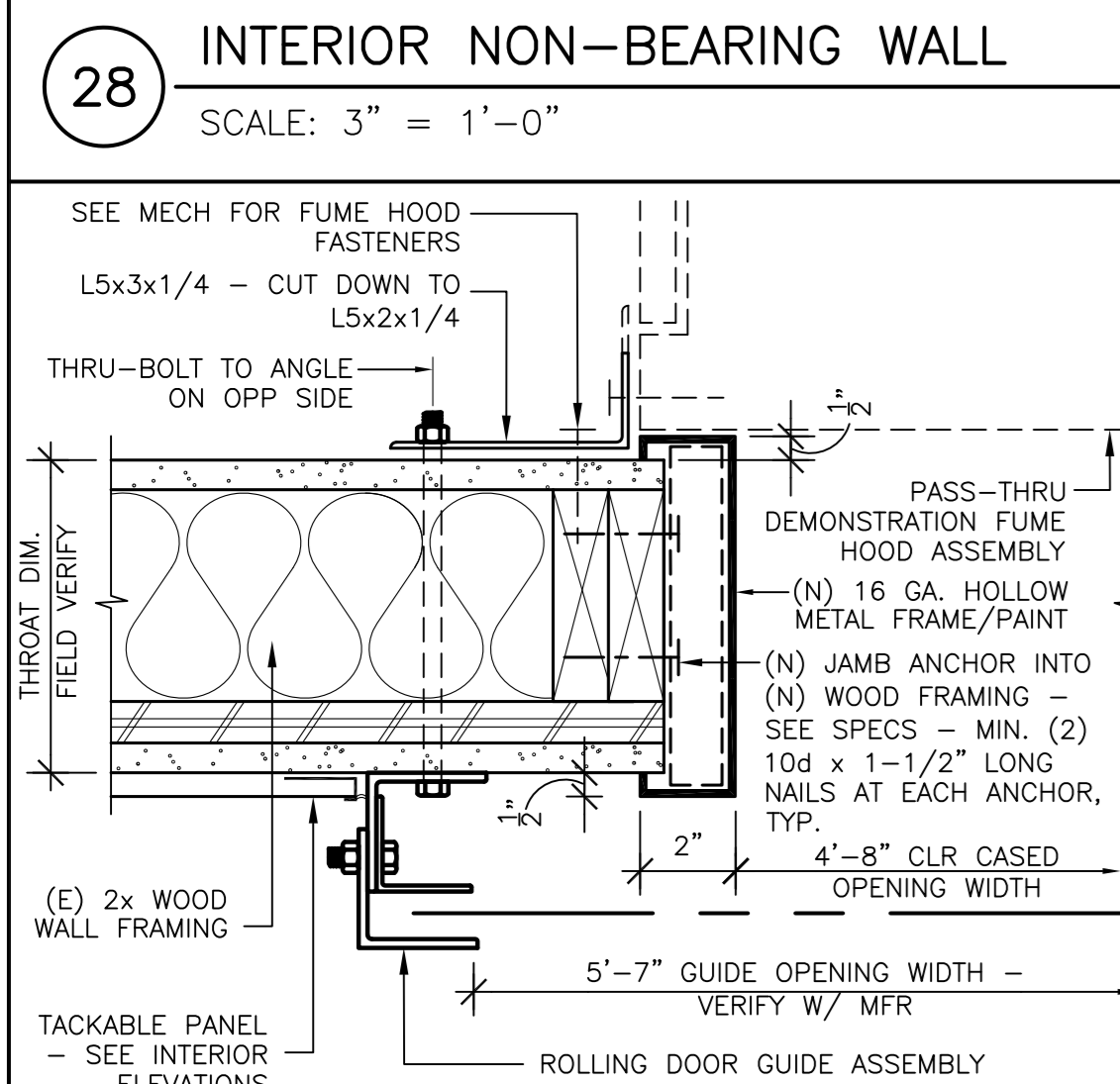

27 ROLL-UP DOOR JAMB
 SCALE: 3" = 1'-0"

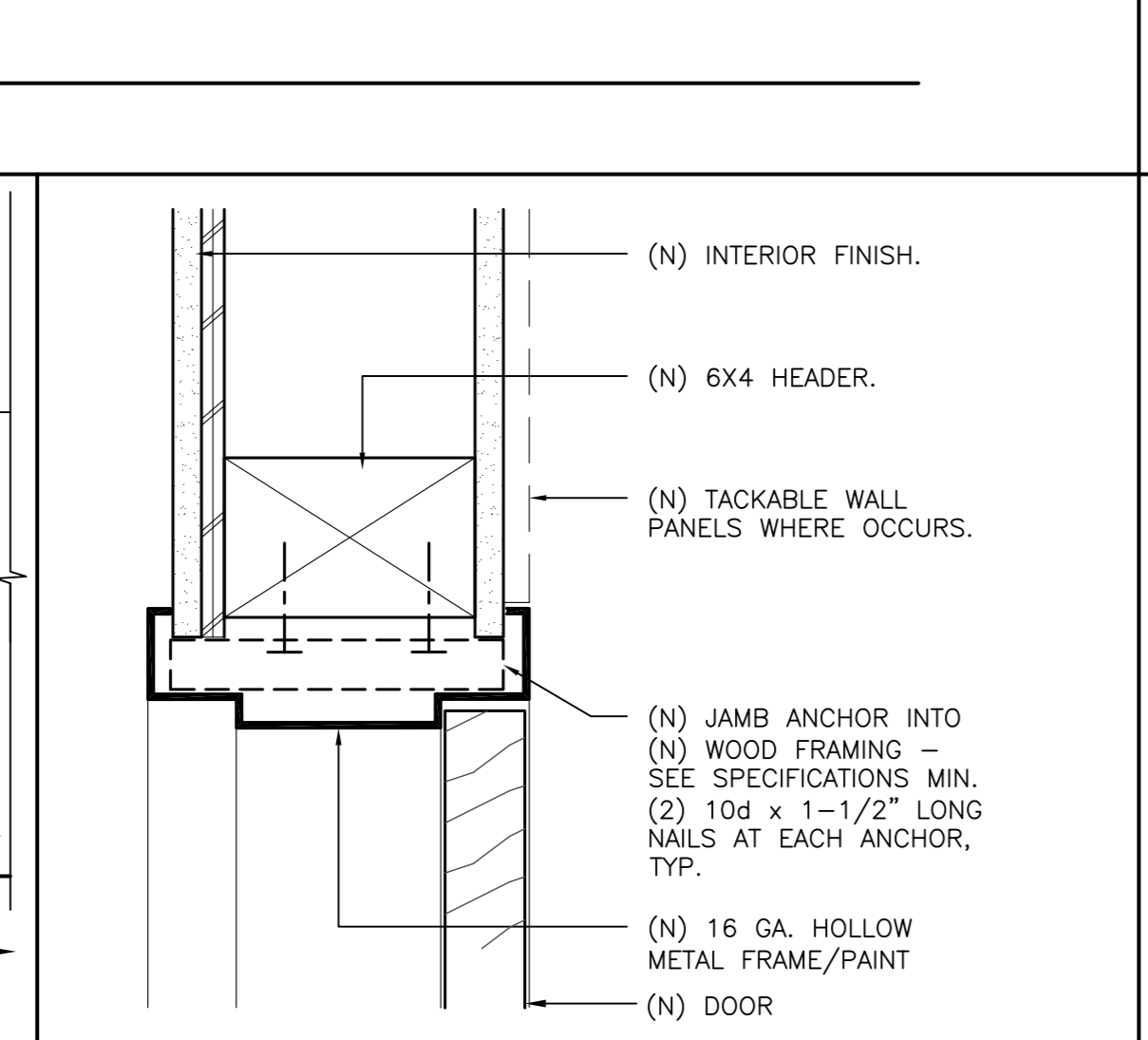

22 INTERIOR DOOR HEAD
 SCALE: 3" = 1'-0"

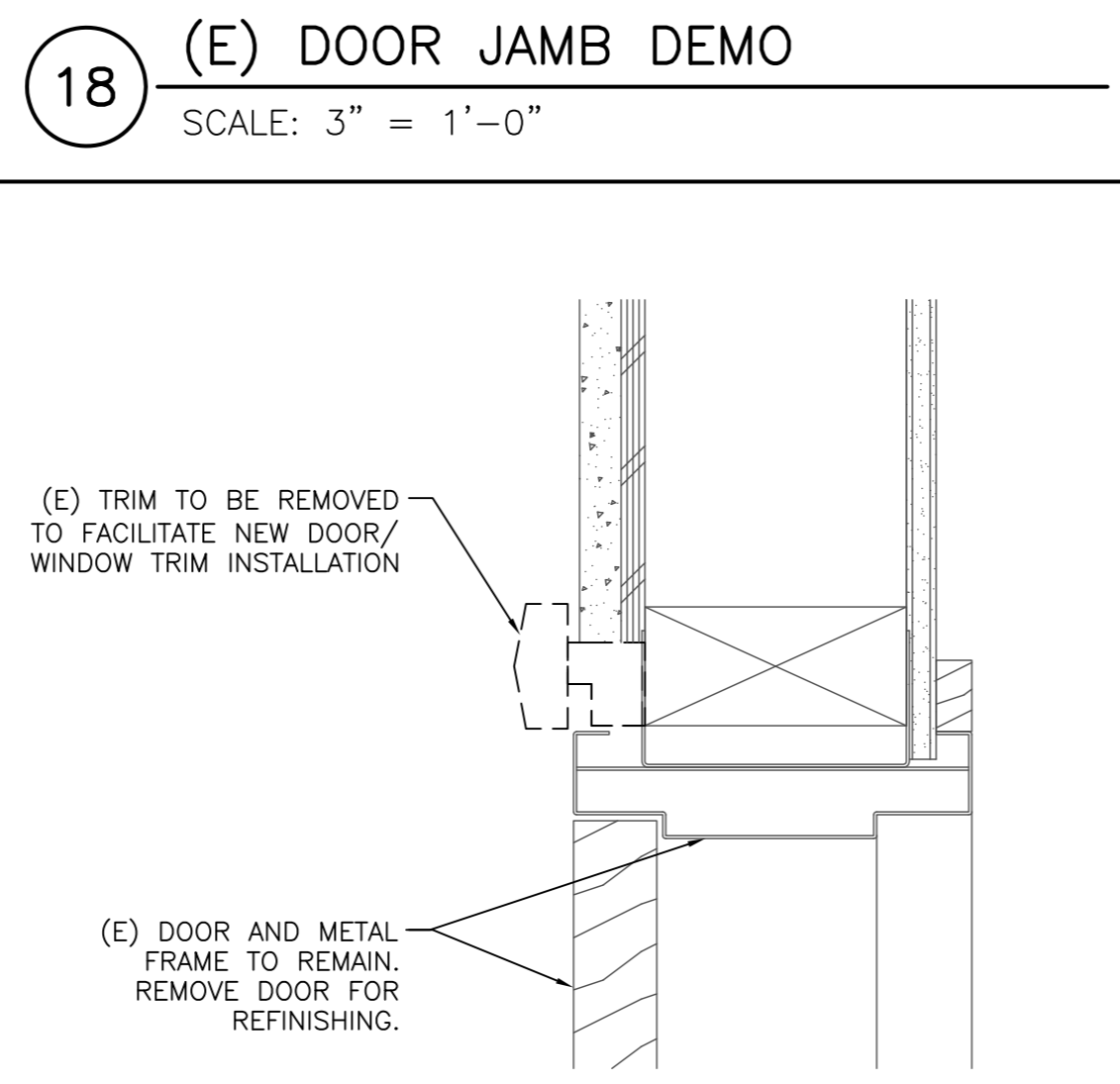

17 (E) DOOR JAMB DEMO
 SCALE: 3" = 1'-0"

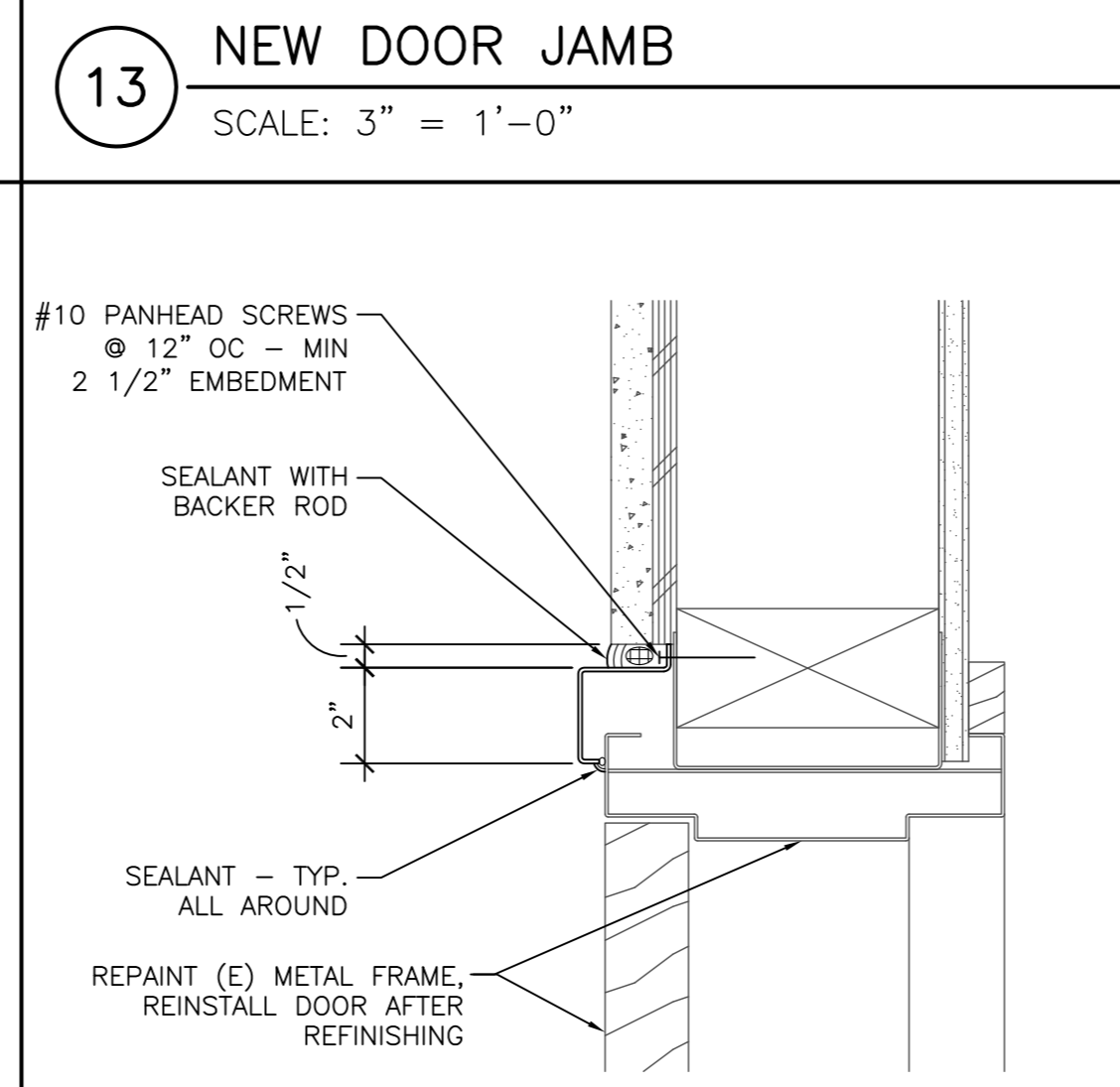

12 NEW DOOR JAMB
 SCALE: 3" = 1'-0"

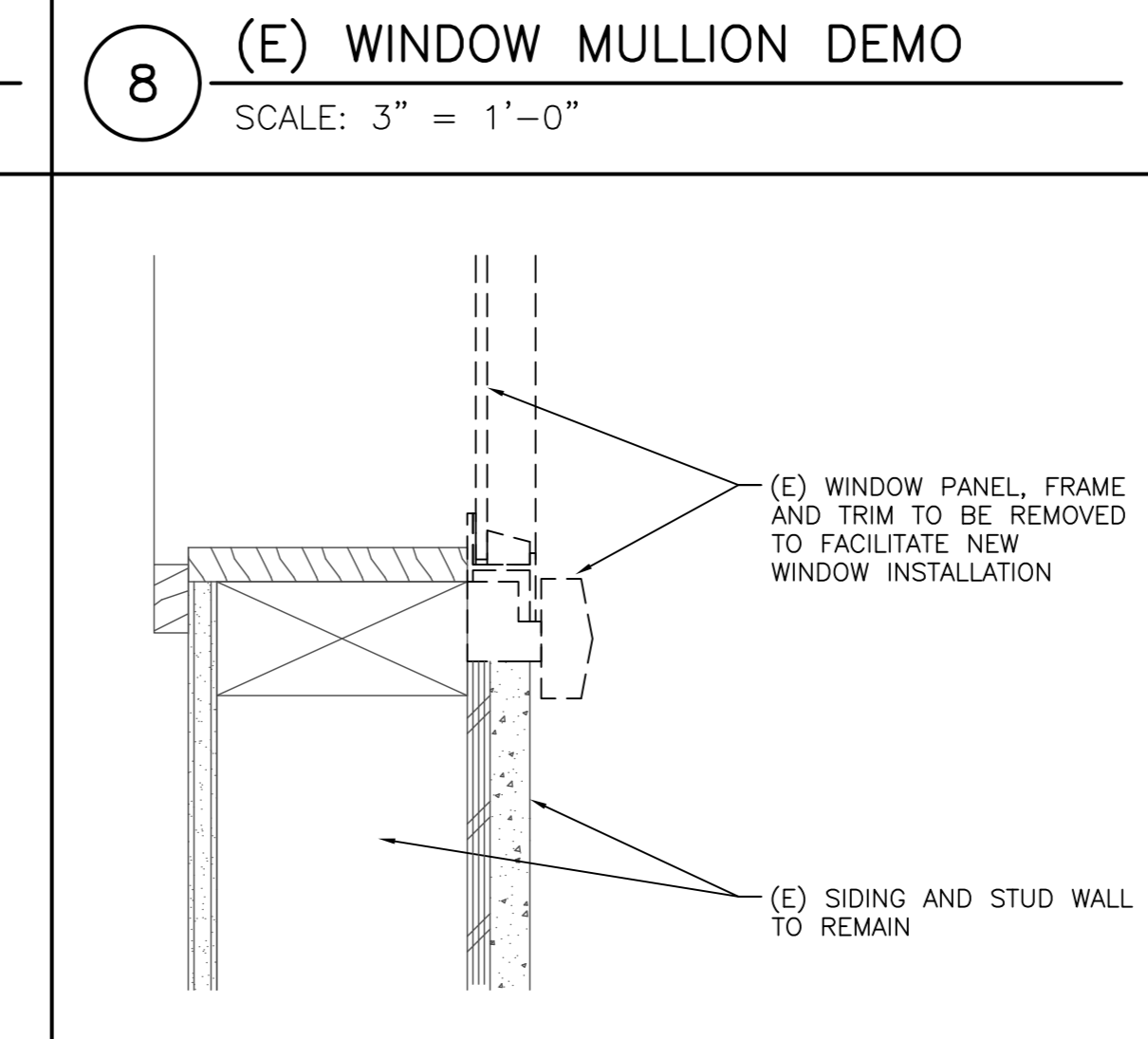

7 (E) WINDOW JAMB DEMO
 SCALE: 3" = 1'-0"

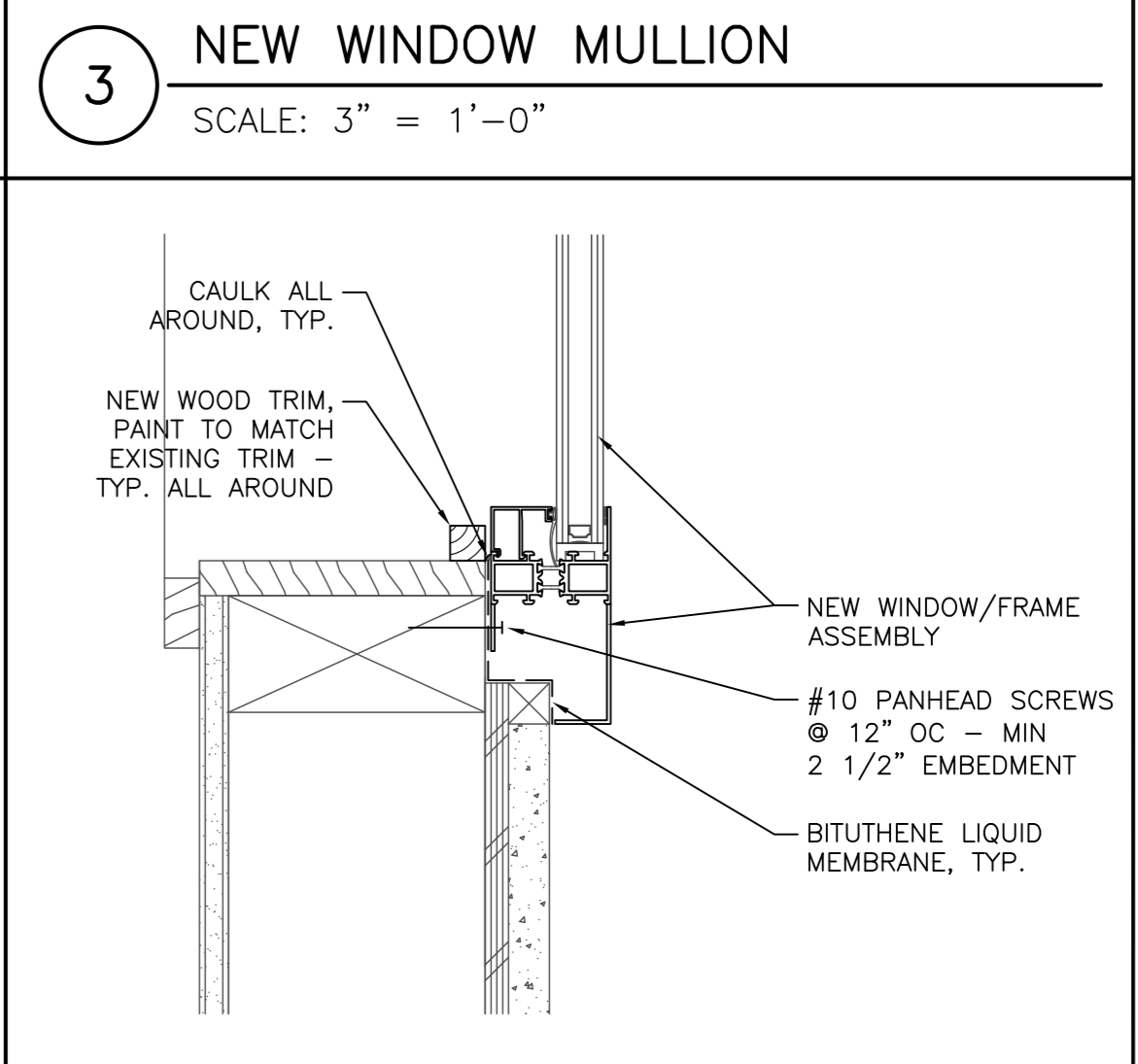

2 NEW WINDOW JAMB
 SCALE: 3" = 1'-0"

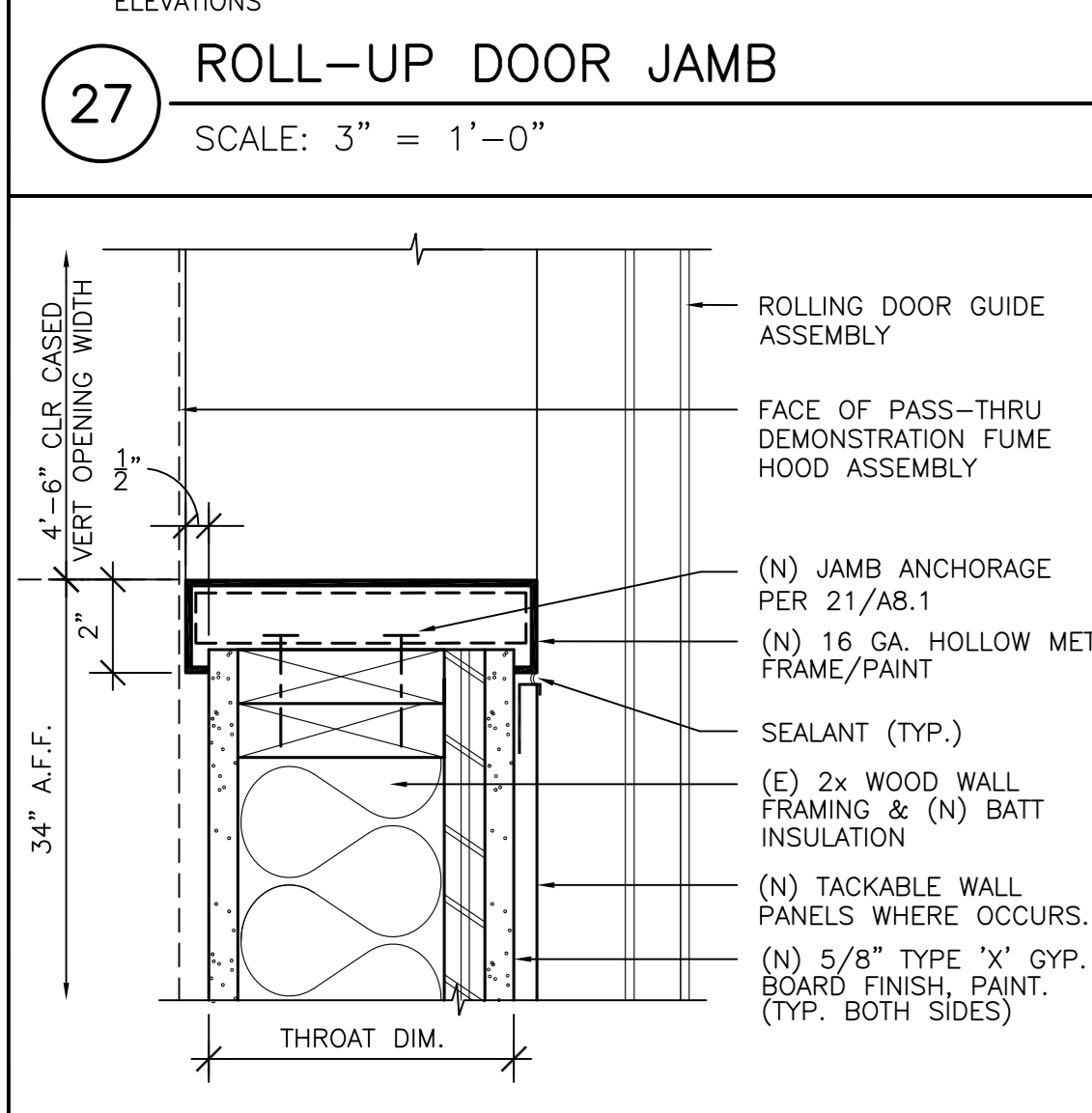

26 ROLL-UP DOOR SILL
 SCALE: 3" = 1'-0"

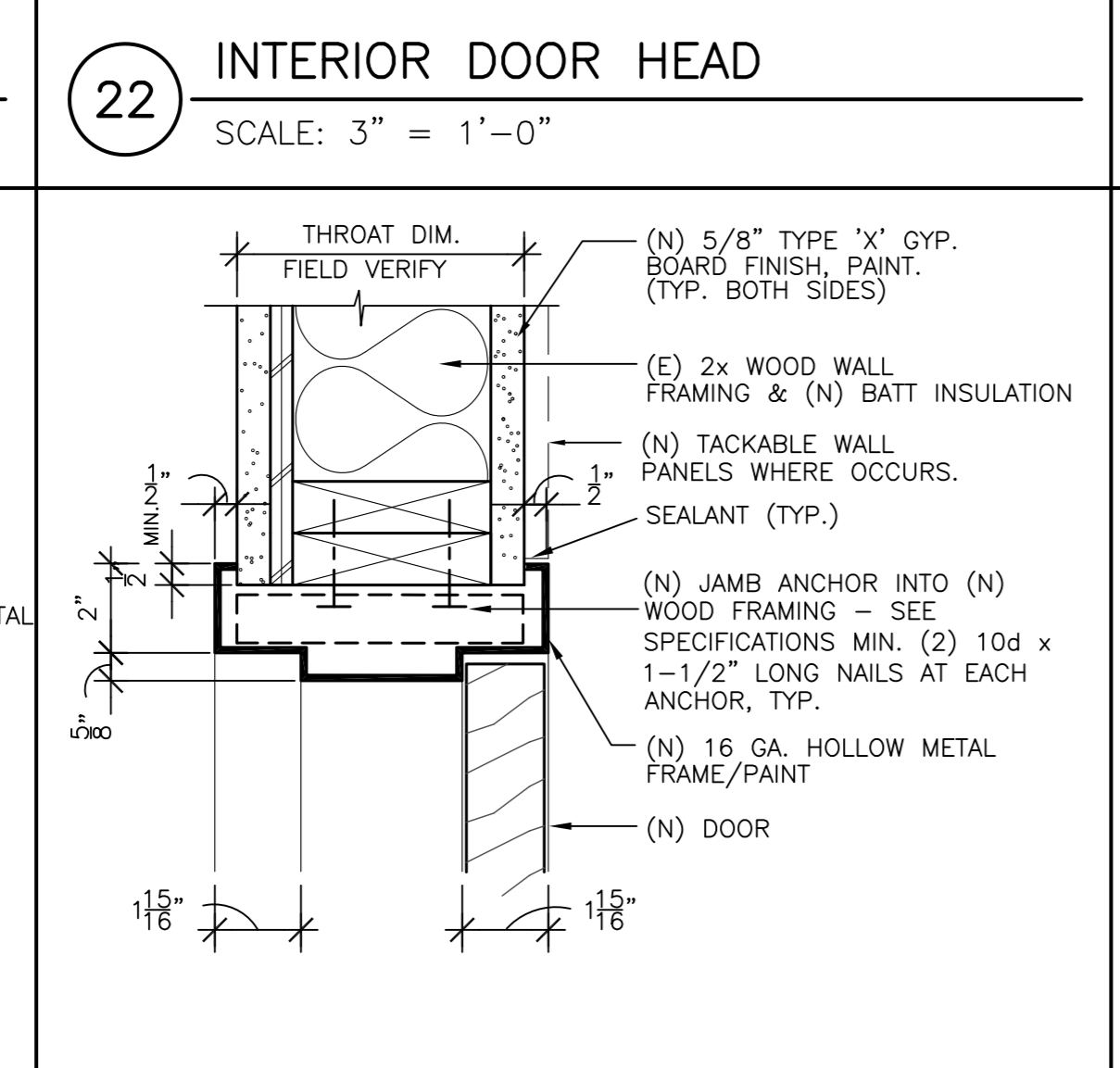

21 INTERIOR JAMB
 SCALE: 3" = 1'-0"

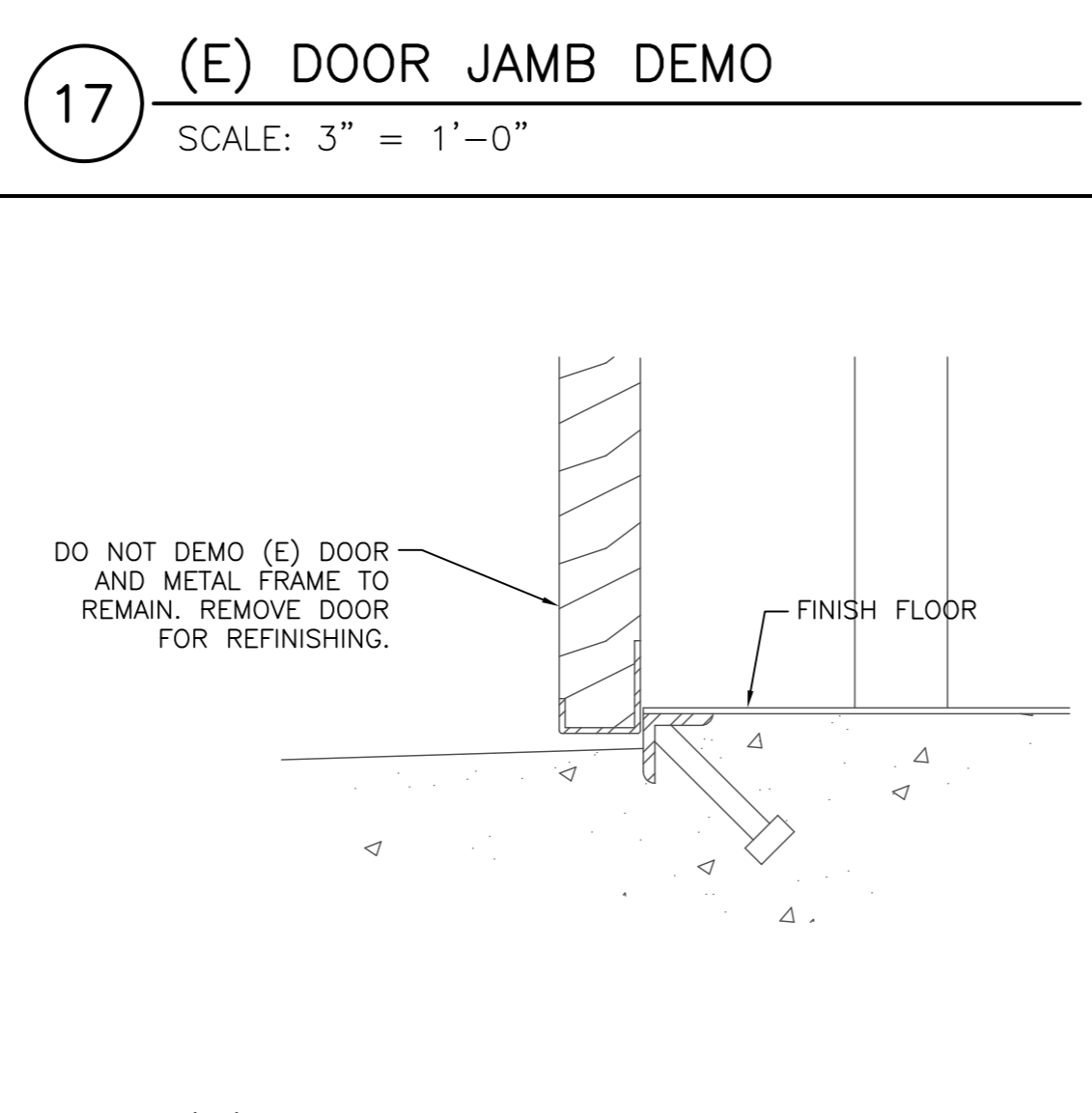

16 (E) DOOR THRESHOLD DETAIL
 SCALE: 3" = 1'-0"

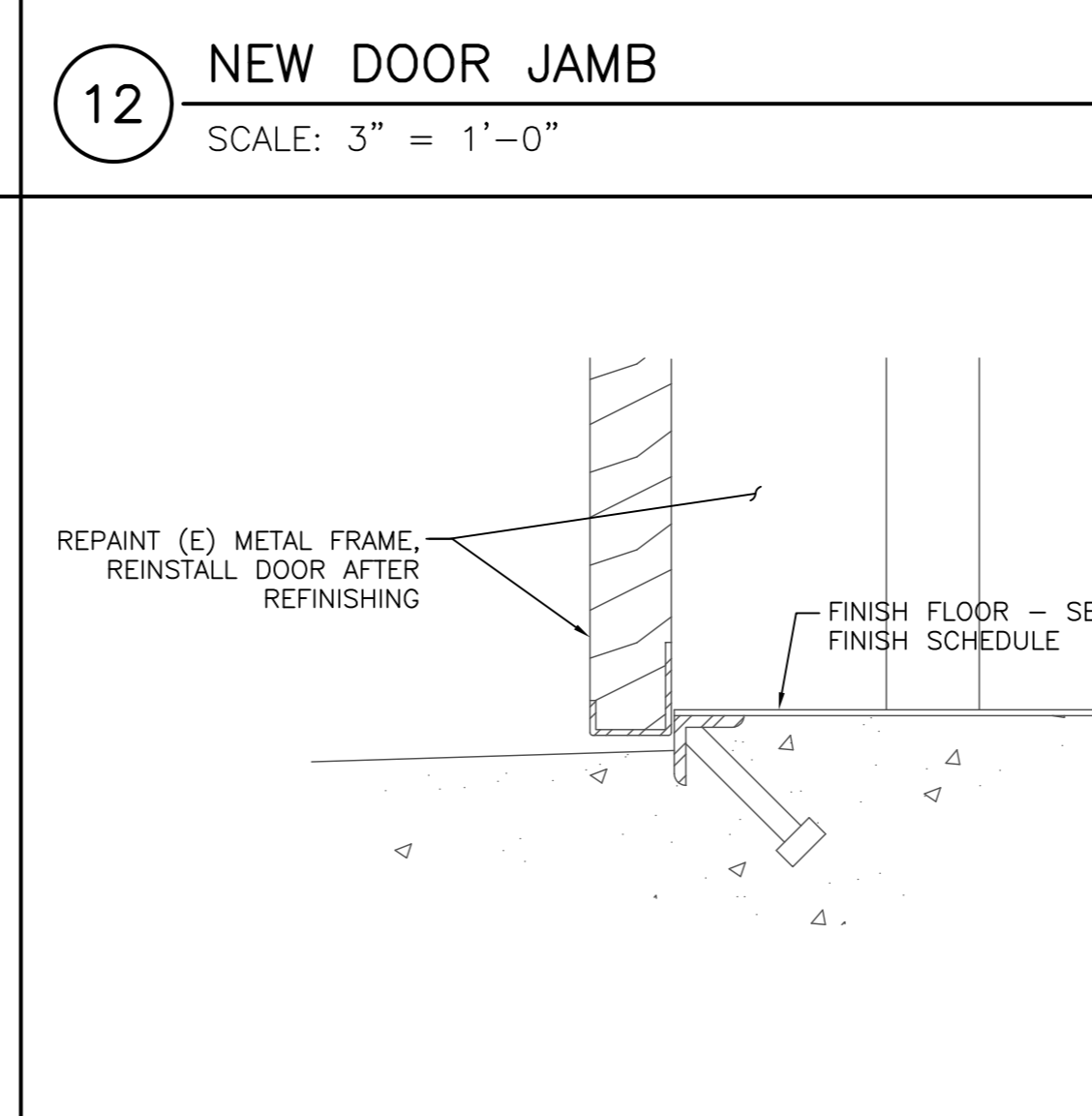

11 NEW DOOR THRESHOLD DETAIL
 SCALE: 3" = 1'-0"

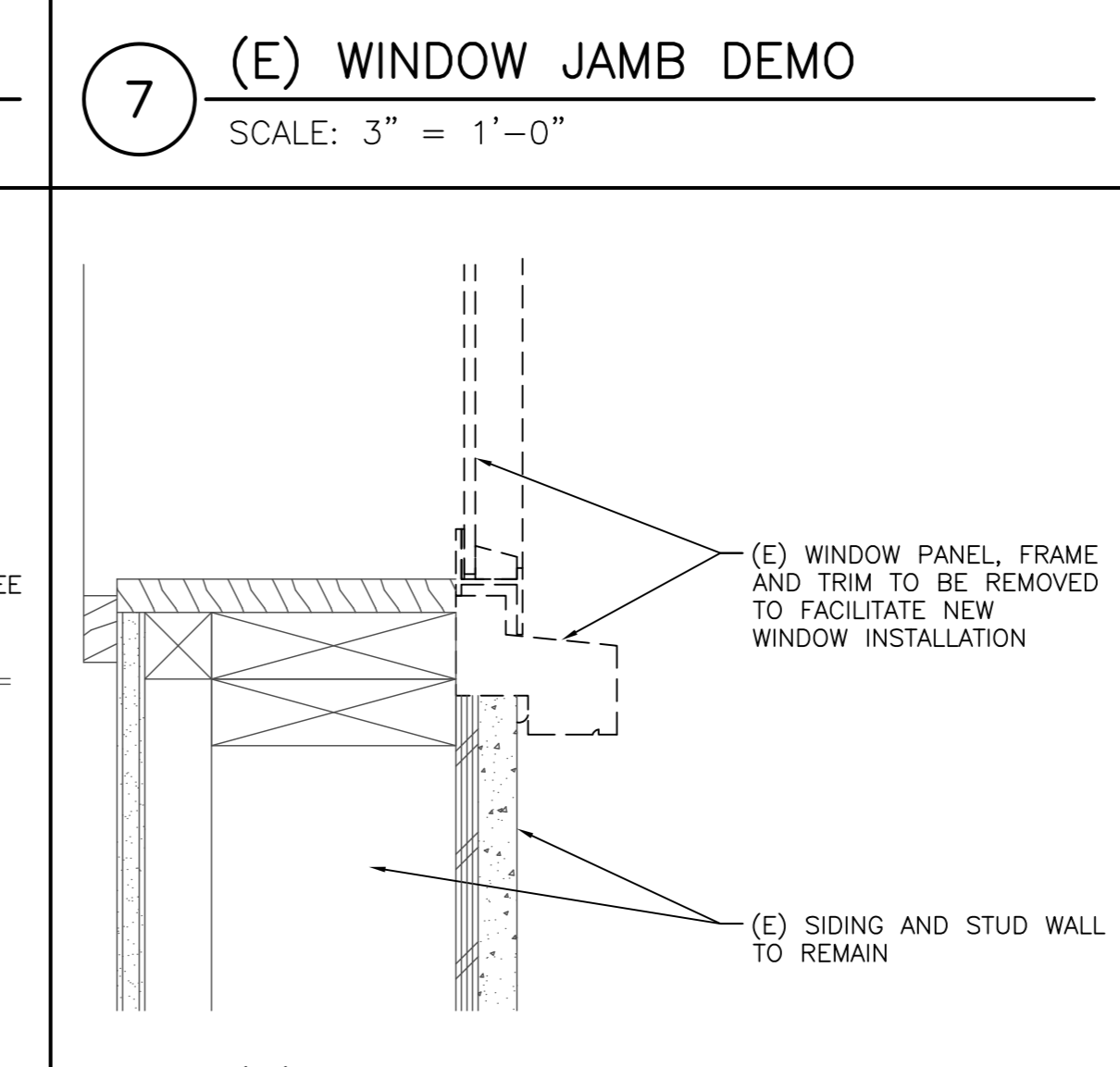

6 (E) WINDOW SILL DEMO
 SCALE: 3" = 1'-0"

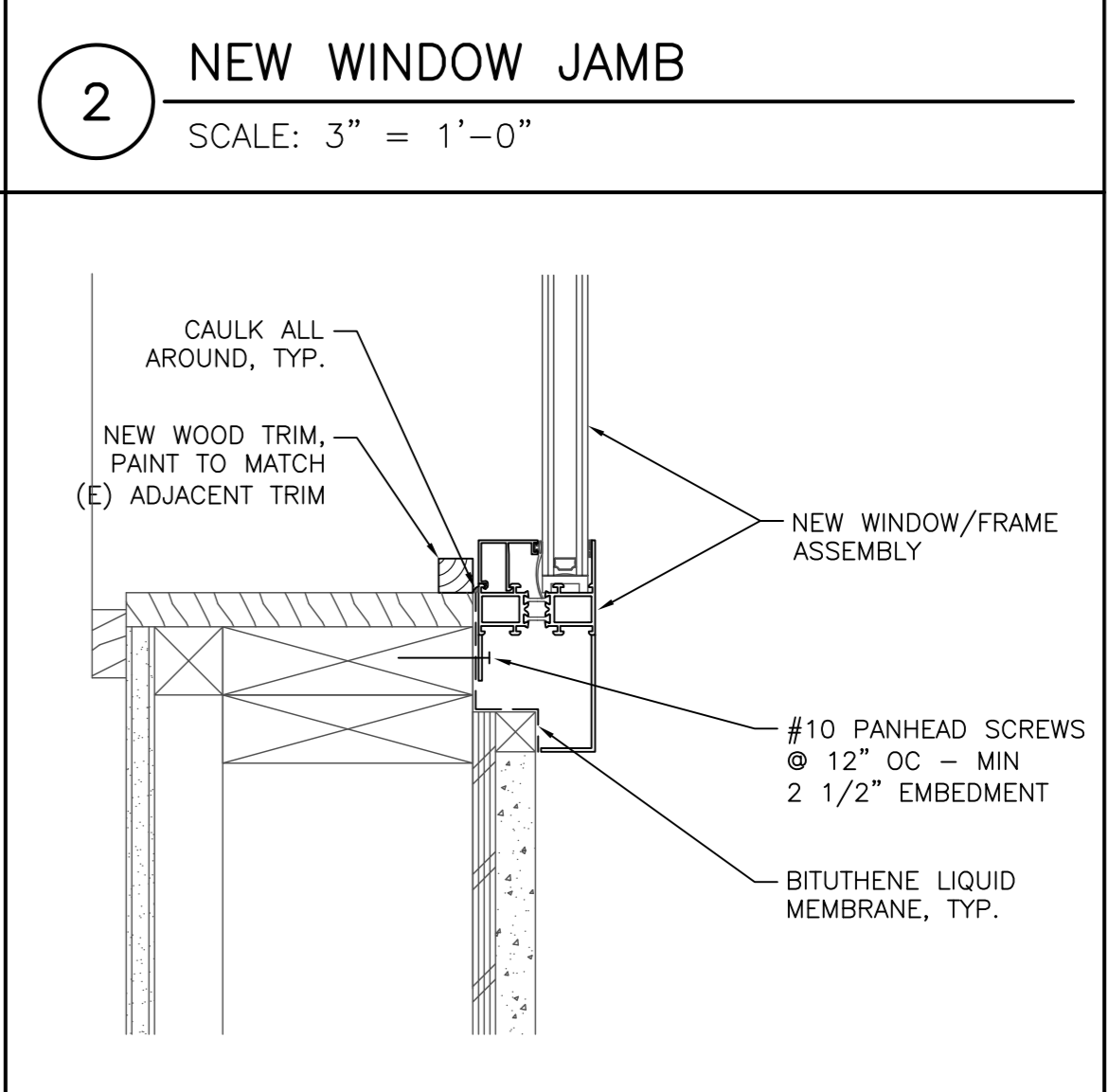

1 NEW WINDOW SILL
 SCALE: 3" = 1'-0"

FILE NO. XX-XX
 IDENTIFICATION STAMP
 DIV. OF THE STATE ARCHITECT
 OFFICE OF REGULATION SERVICES
 APPLICATION NO. 01-
 AC. FLS. SS
 DATE
 DIVISION OF THE STATE ARCHITECT
 revision date: by:

CONSULTANT
 nacht & lewis
 600 Q Street, Suite 100
 Sacramento, CA 95811
 www.nachtlewis.com
 916.329.4000

ARCHITECT

REVISIONS		
NO.	DESCRIPTION	DATE

ONE AND ONE-HALF INCH = ONE FOOT
ONE INCH = ONE FOOT
THREE-QUARTERS INCH = ONE FOOT
ONE-HALF INCH = ONE FOOT
ONE-QUARTER INCH = ONE FOOT
ONE-EIGHTH INCH = ONE FOOT
ONE-SIXTEENTH INCH = ONE FOOT
ONE INCH = TWENTY FEET

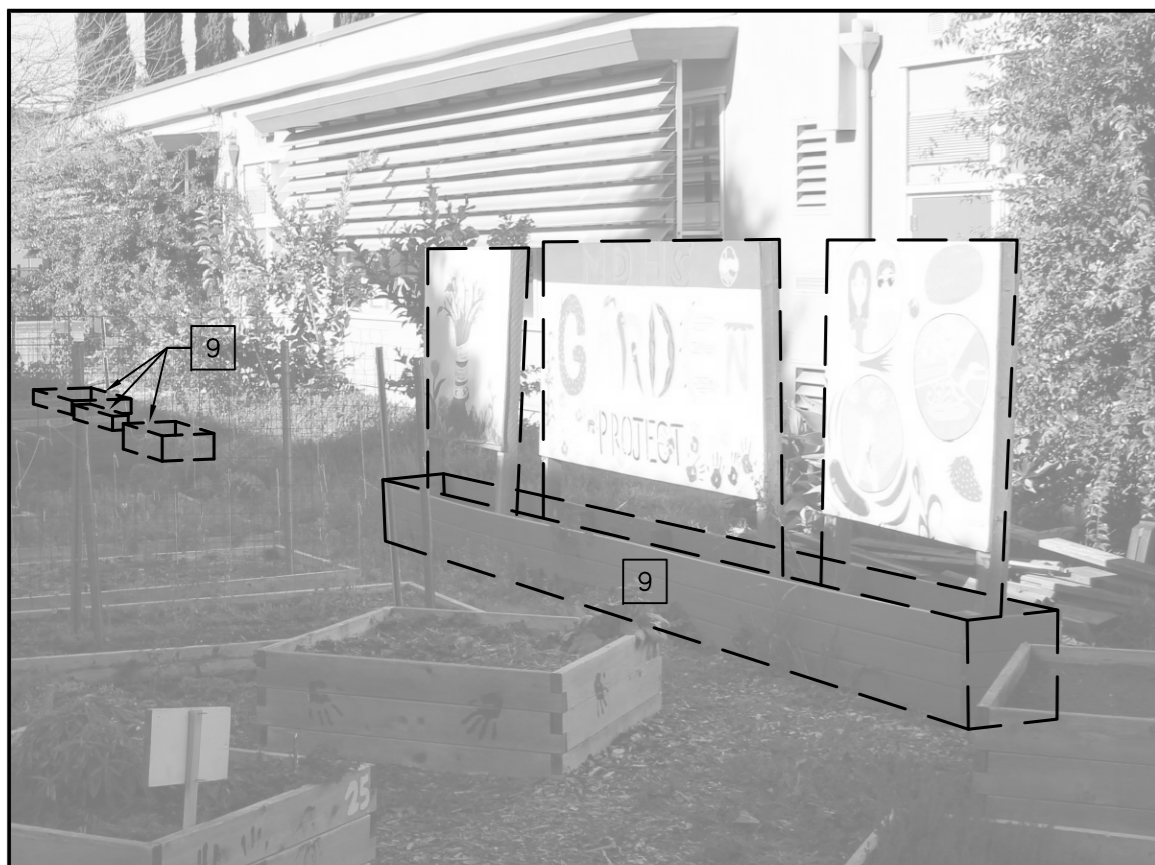

25 GARDEN AREA PLANTERS/SIGNS
NO SCALE

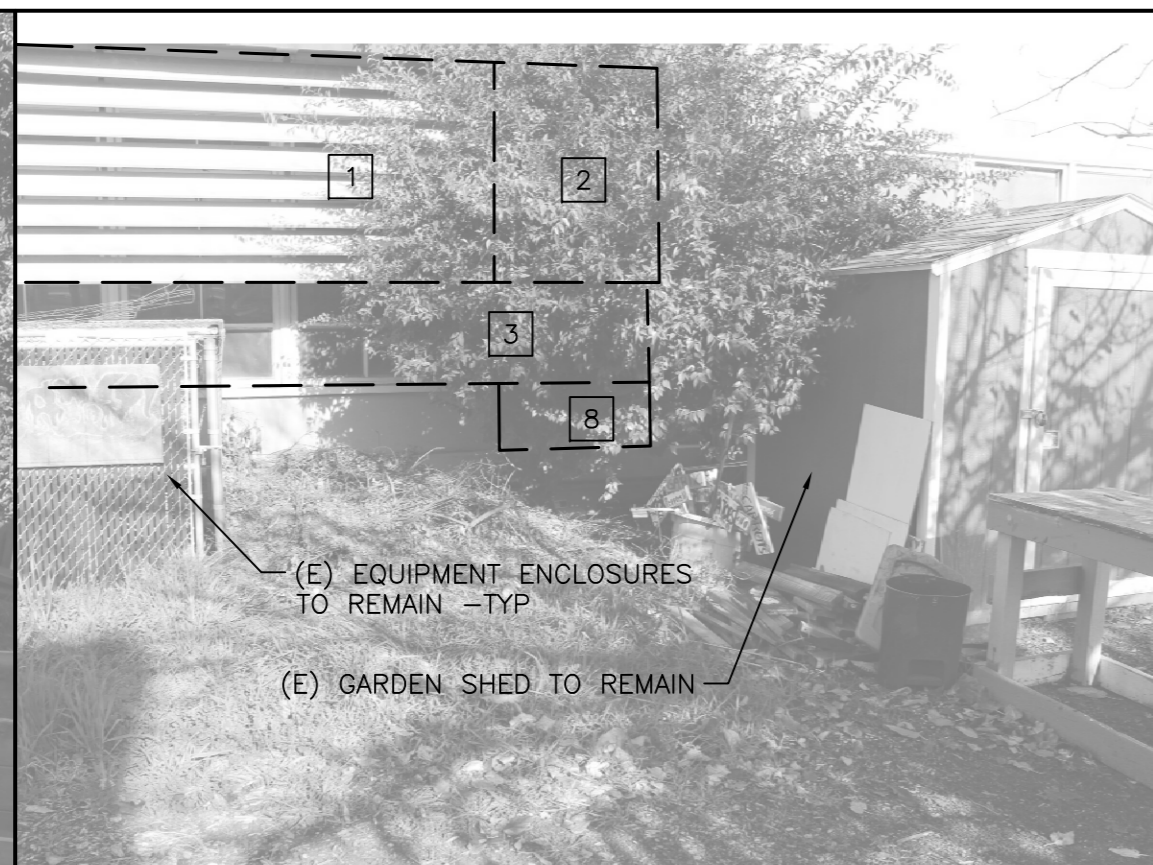

24 WINDOW & SHADE DEMO
NO SCALE

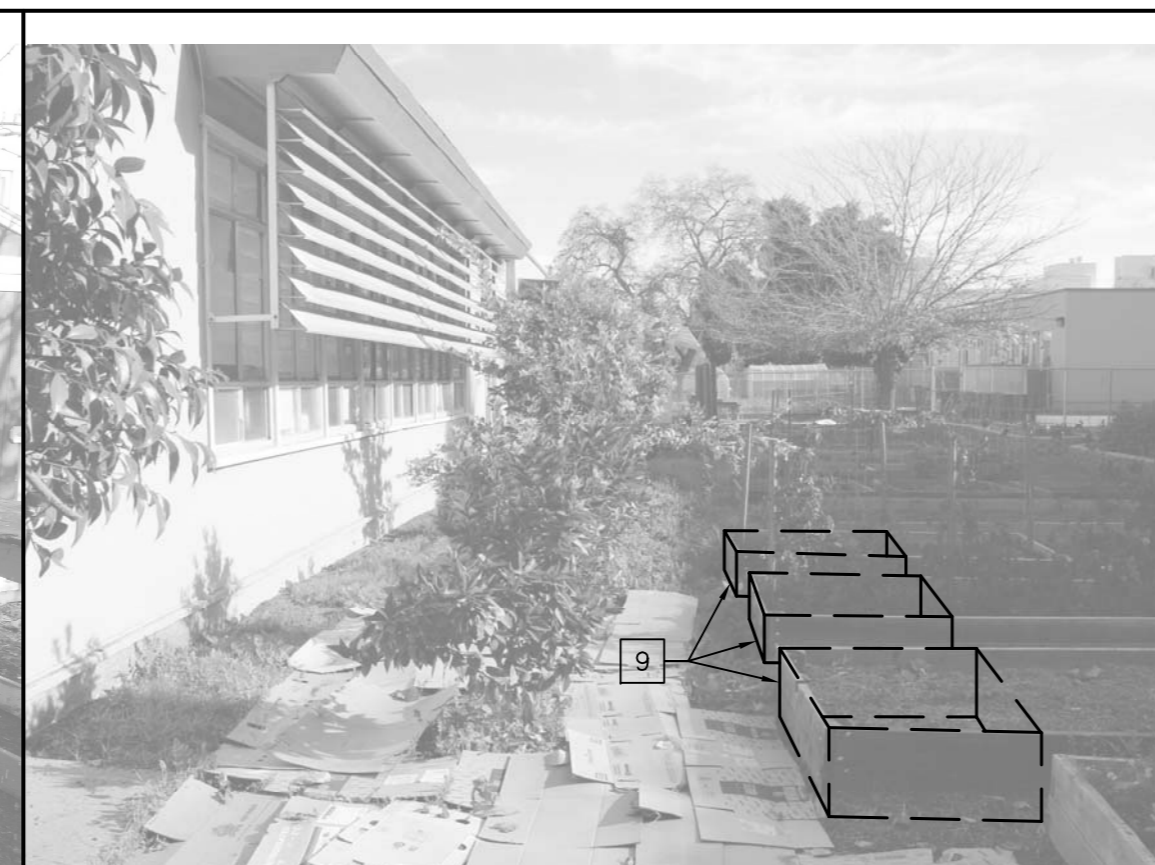

23 GARDEN AREA PLANTERS
NO SCALE



22 DOOR/WINDOW & SHADE DEMO
SOUTH WALL



21 DOOR/WINDOW & SHADE DEMO
SOUTH WALL

GENERAL NOTES

- PICTURES/NOTES PROVIDED FOR REFERENCE ONLY.
- SEE PLANS FOR SPECIFIC INFORMATION NOT PROVIDED HERE.
- SEE FLOOR PLANS AND FINISH SCHEDULE FOR ITEMS NOT NOTED ON ELEVATIONS.
- COORDINATE ALL WORK SHOWN WITH OTHER TRADES.
- WALKS IN LANDSCAPED/GARDEN AREAS: REMOVE EXISTING LANDSCAPING AND PLANTERS ONLY TO THE EXTENT REQUIRED TO INSTALL THE NEW WORK. COORDINATE WITH THE CONSTRUCTION MANAGER PRIOR TO REMOVAL OF SHRUBS/PLANTERS TO DETERMINE IF THE DISTRICT WISHES TO HAVE PLANTS/MATERIAL SALVAGED BACK TO THE DISTRICT FOR RELOCATION BY DISTRICT GROUNDS CREW. NOTIFY THE CONSTRUCTION MANAGER IN THE EVENT THAT TREES PROHIBIT INSTALLATION OF THE WALKS IN THE LOCATION DENOTED ON THE DRAWINGS FOR FURTHER DIRECTION ON HOW TO PROCEED. REPAIR ANY PLANTERS, LANDSCAPE IRRIGATION LINES OR SPRINKLERS THAT ARE DAMAGED BY THE INSTALLATION OF THE NEW WORK. RELOCATE ANY PLANTERS, LANDSCAPE IRRIGATION LINES OR SPRINKLERS THAT OCCUR WITHIN THE EXTENTS OF THE NEW WALKS. UPON COMPLETION OF THE WORK, RESTORE THE LANDSCAPING PLANTERS IN THE IMMEDIATE VICINITY OF THE YARD TO MATCH THE ADJACENT PLANTING/GARDENS (I.E. RESTORE LAWN AREAS, GROUND COVERS, ETC.). LAWN AREAS SHALL BE RESTORED WITH SOG.

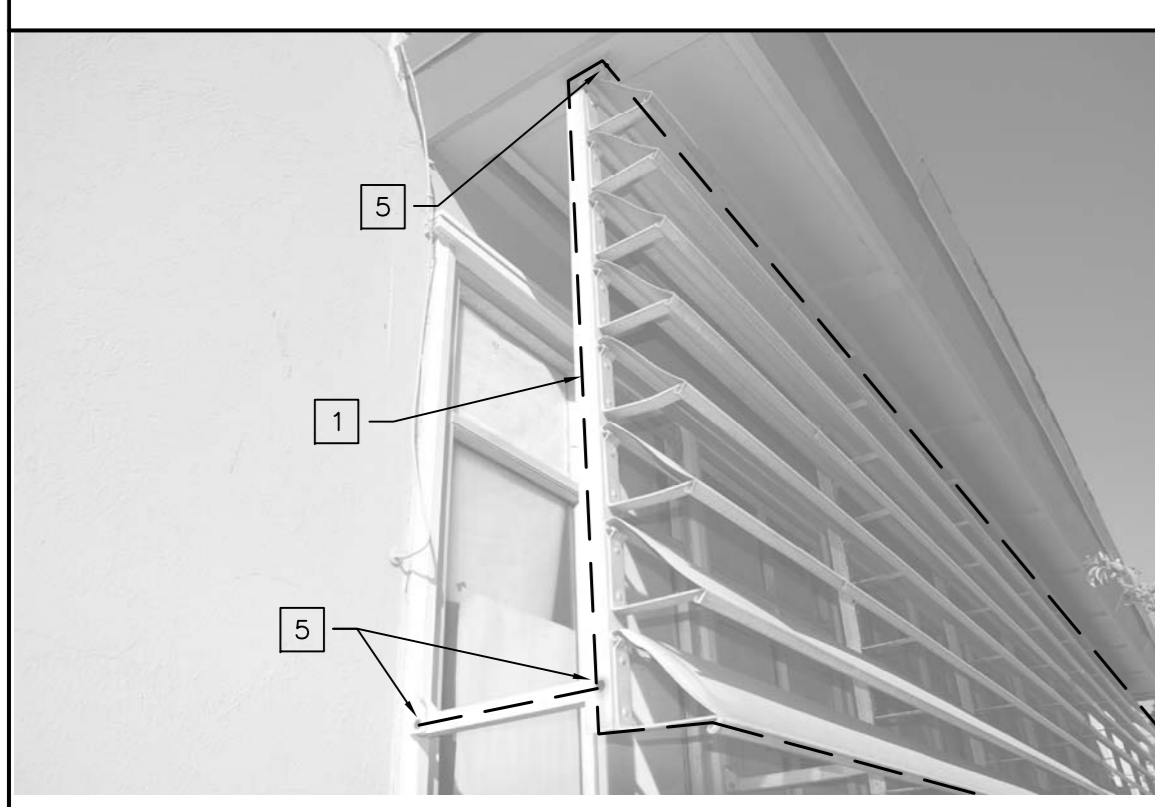

20 TYP. WINDOW SHADE ATTACHMENT
SOUTH WALL



19 WALL, WINDOW & SHADE DEMO
SOUTH WALL

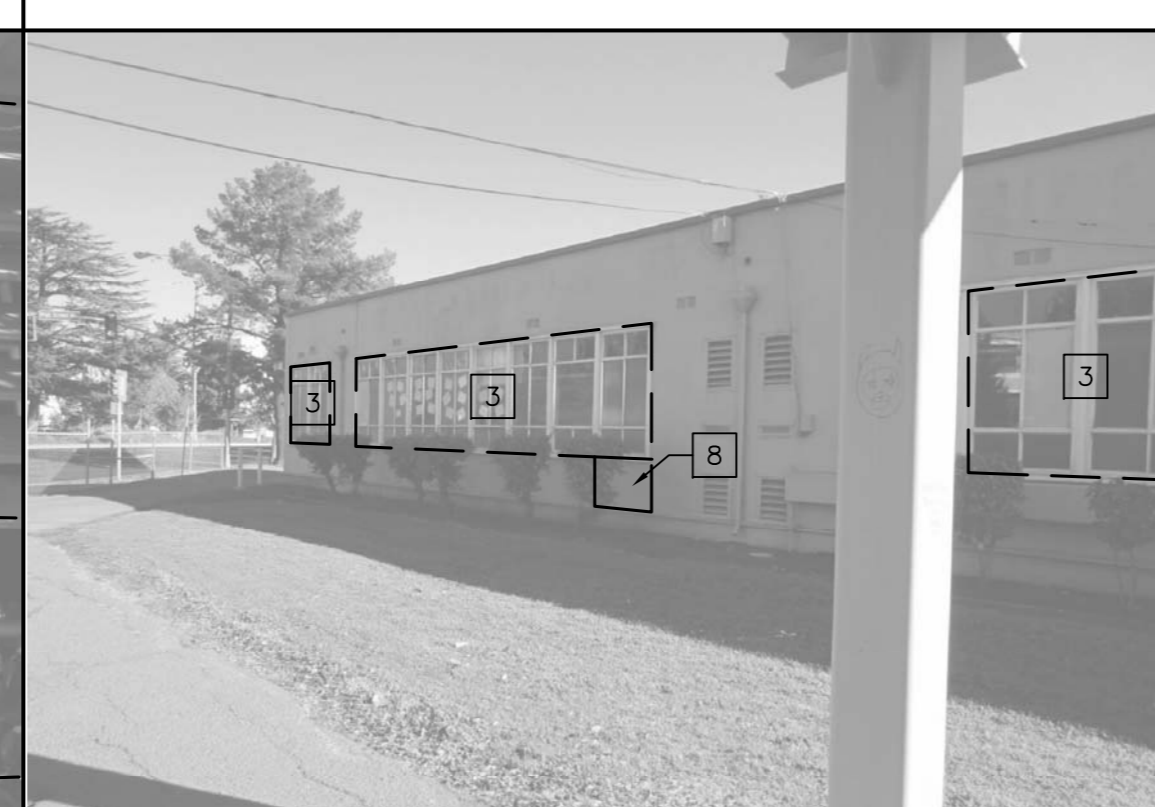

18 CLASSROOM/PREP WINDOWS
NORTH WALL

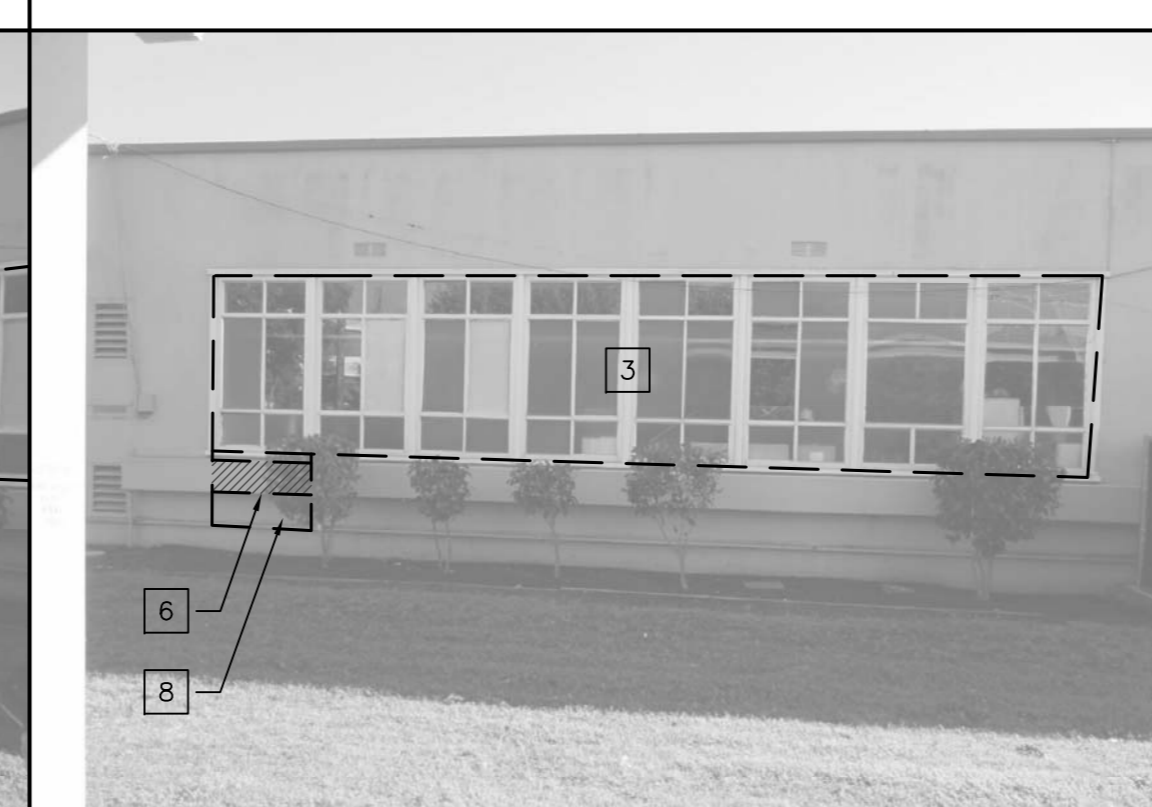

17 CLASSROOM WINDOW/MECH CHASE
NORTH WALL



16 PREP ROOM DOOR/WINDOWS
NORTH WALL

EXTERIOR KEYNOTES:
THESE NEW WORK KEYNOTES APPLY TO THIS SHEET ONLY

- REMOVE SHADES AND BRACKETS TO PERMIT WINDOW REPLACEMENT
- CUT BACK PORTION OF SHADE AS REQUIRED FOR ACCESS TO NEW DOOR
- REMOVE AND REPLACE (E) WINDOWS
- REMOVE AND REPLACE (E) DOOR (AND TRANSOM WHERE OCCURS)
- TYPICAL ATTACHMENT POINTS FOR WINDOW SHADES - REMOVE AND REINSTALL IN-KIND
- CUT PORTION OF (E) EXTERIOR SURFACE MOUNTED RACEWAY AND REROUTE RACEWAY AND REFRIGERANT LINES PER MECHANICAL
- REMOVE (E) DOOR, FRAME AND TRANSOM. INFILL WITH NEW STUDS TO MATCH (E) WALLS.
- CUT WALL AS REQUIRED FOR NEW DOOR/FRAME INSTALLATION
- CUT BACK PLANTER AS REQUIRED FOR NEW SIDEWALK INSTALLATION
- DEMOLISH OR RELOCATE SIGNAGE AND BASE PER DISTRICTS PREFERENCE



15 HVAC AT EXTERIOR DOOR
PREP ROOM

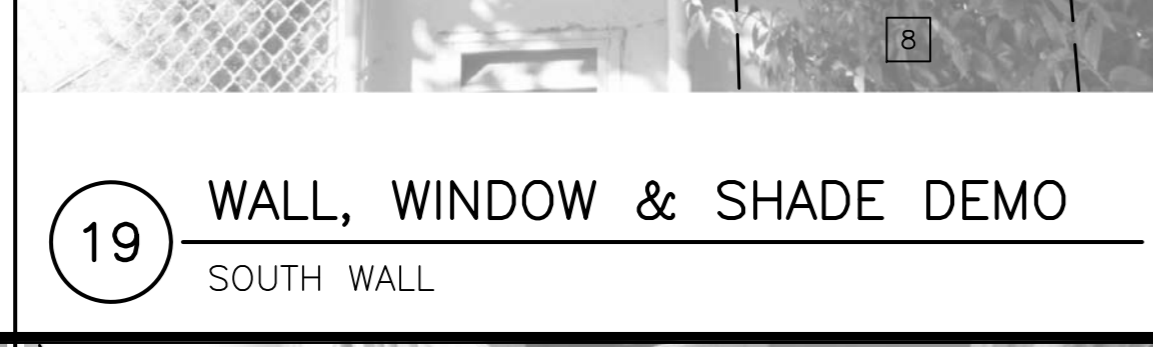

14 FLOOR TRANSITION
PREP ROOM



13 PARTITION WALL/DOOR
PREP ROOM

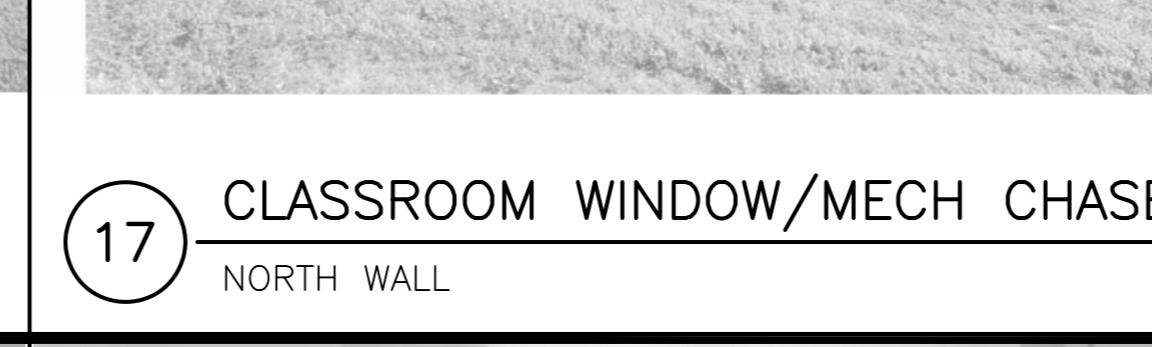

12 CORRIDOR WALL
PREP ROOM

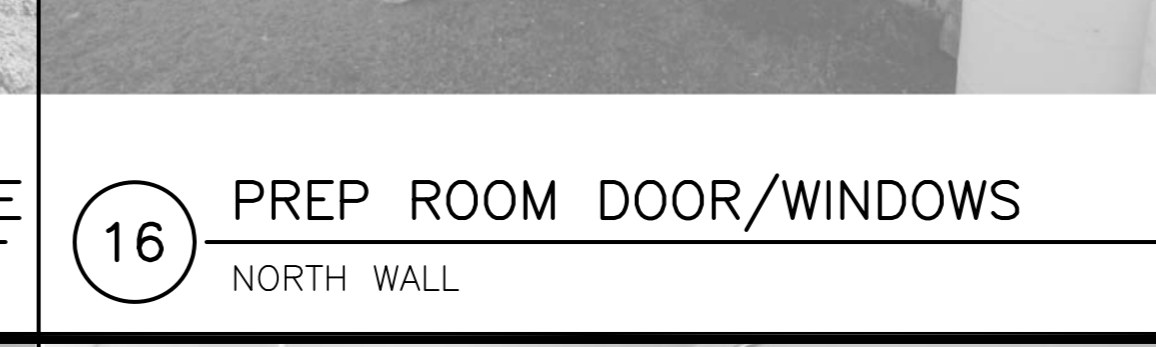

11 CASEWORK/COUNTER/WAINSCOT
PREP ROOM

INTERIOR KEYNOTES:
THESE NEW WORK KEYNOTES APPLY TO THIS SHEET ONLY

- REMOVE AND REFINISH UPPER CABINETS, REINSTALL AT NEW LOCATIONS INDICATED ON INTERIOR ELEVATIONS
- DEMOLISH (E) CASEWORK/COUNTERS
- REMOVE (E) DOOR AND FRAME. REPLACE WITH NEW DOOR AND FRAME WHERE INDICATED ON PLANS
- REMOVE (E) MARKERBOARDS, TACKBOARD, TRIM AND WAINSCOT. REFINISH WALL PER FINISH SCHEDULE
- DEMOLISH ENTIRE WALL, DOOR AND FRAME.
- REMOVE (E) AC UNIT AND INFILL AND FINISH OPENING TO MATCH ADJACENT WALLS.
- REMOVE AND REPLACE ALL CEILING TILES, TYPICAL
- (E) HVAC/DUCTING TO REMAIN, UNLESS NOTED OTHERWISE
- SEE EXTERIOR KEYNOTE 3
- (E) CURTAINS AND RAIL TO BE REMOVED - TYP.



10 CLASSROOM FRONT ENTRY AREA
CLASSROOM



9 FRONT ISLAND/TEACHER'S STATION
CLASSROOM



8 WINDOW WALL/TEACHER'S STATION
CLASSROOM



7 WINDOW WALL/CASEWORK
CLASSROOM



6 HVAC AND DUCTING
CLASSROOM

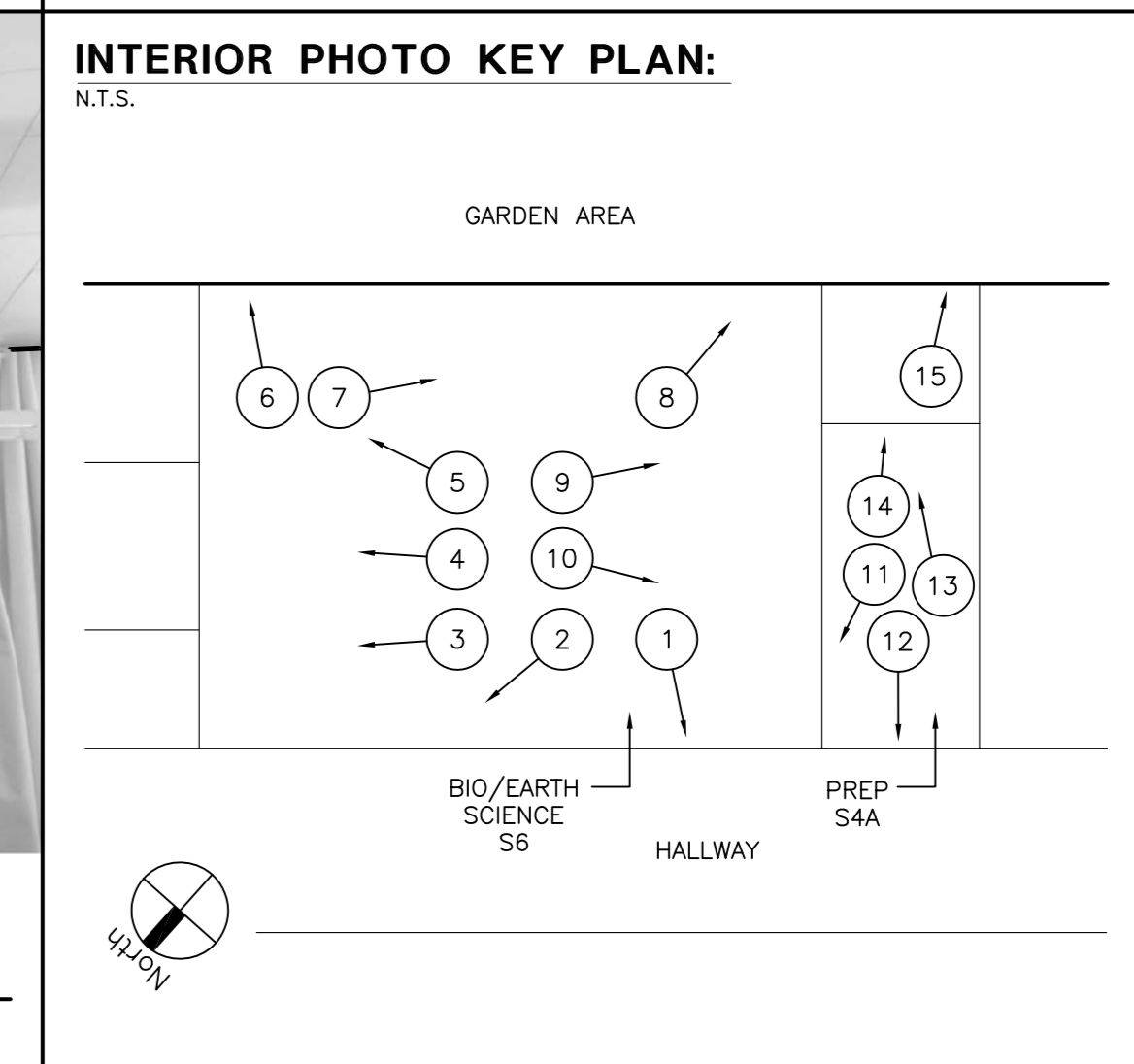

5 WINDOW WALL/CASEWORK
CLASSROOM



4 OVERALL VIEW
CLASSROOM



3 OVERALL END WALL VIEW
CLASSROOM

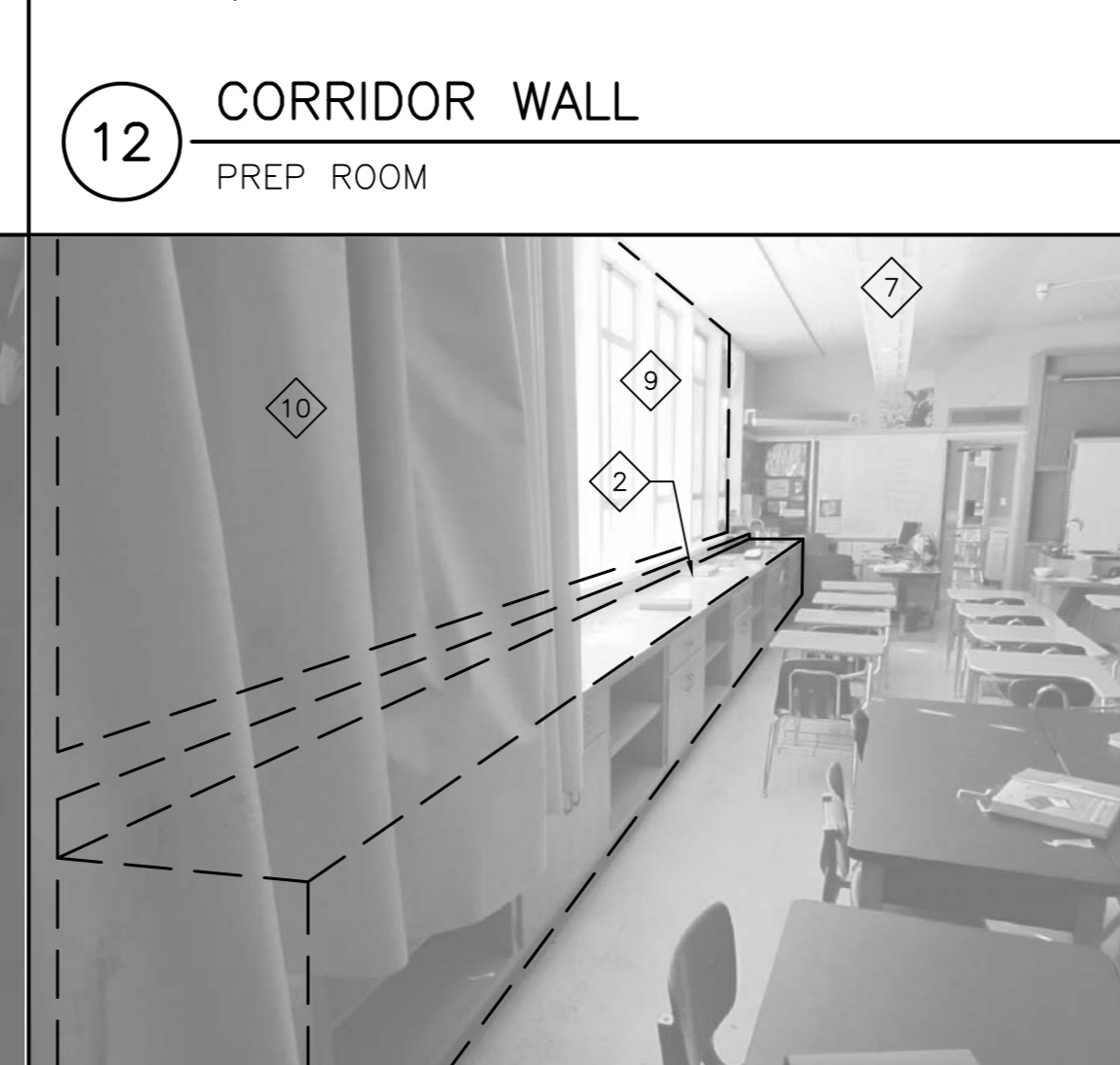

2 CASEWORK/COUNTERTOP
CLASSROOM

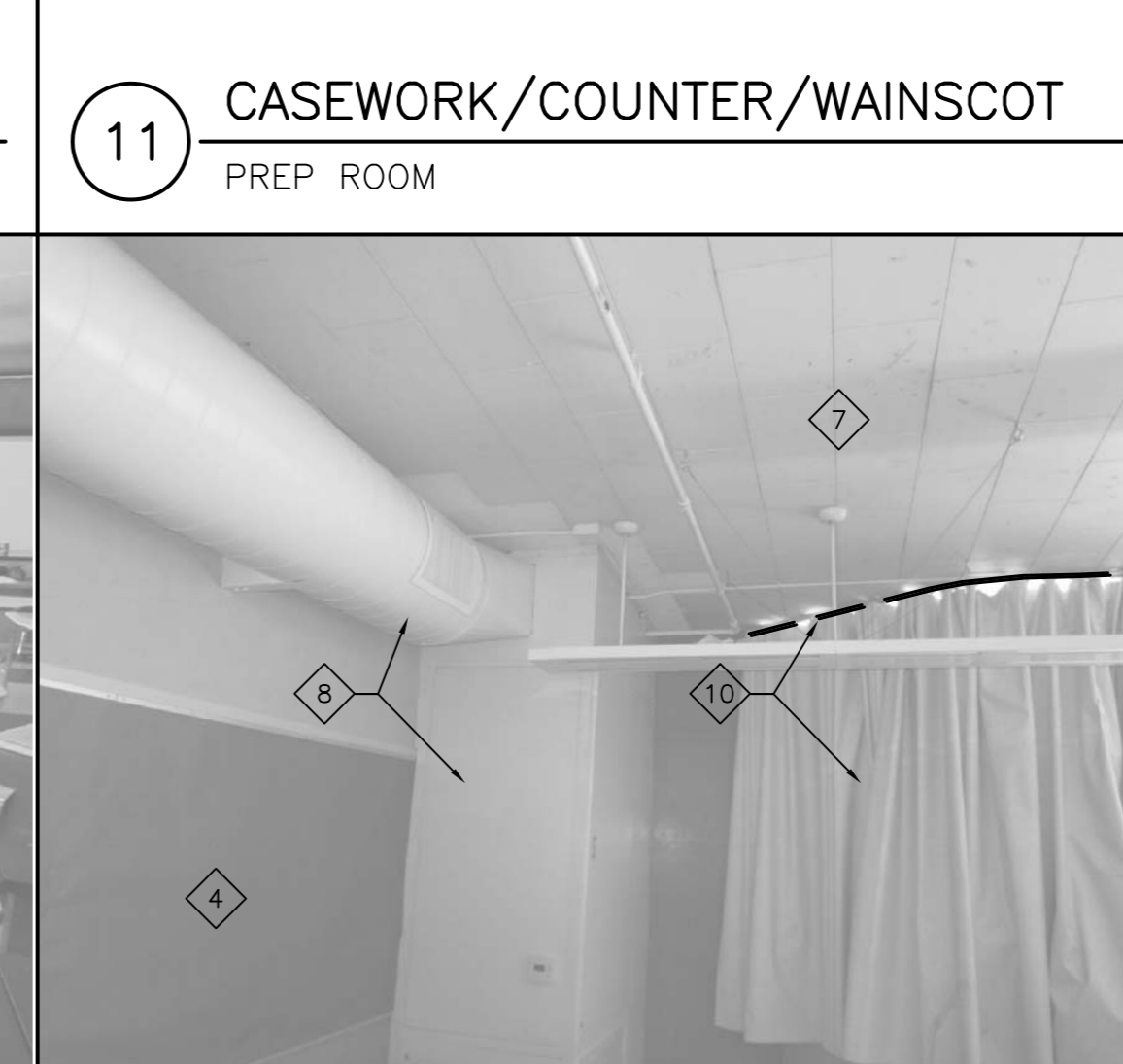

1 SMART BOARD, ISLAND & DOOR
CLASSROOM

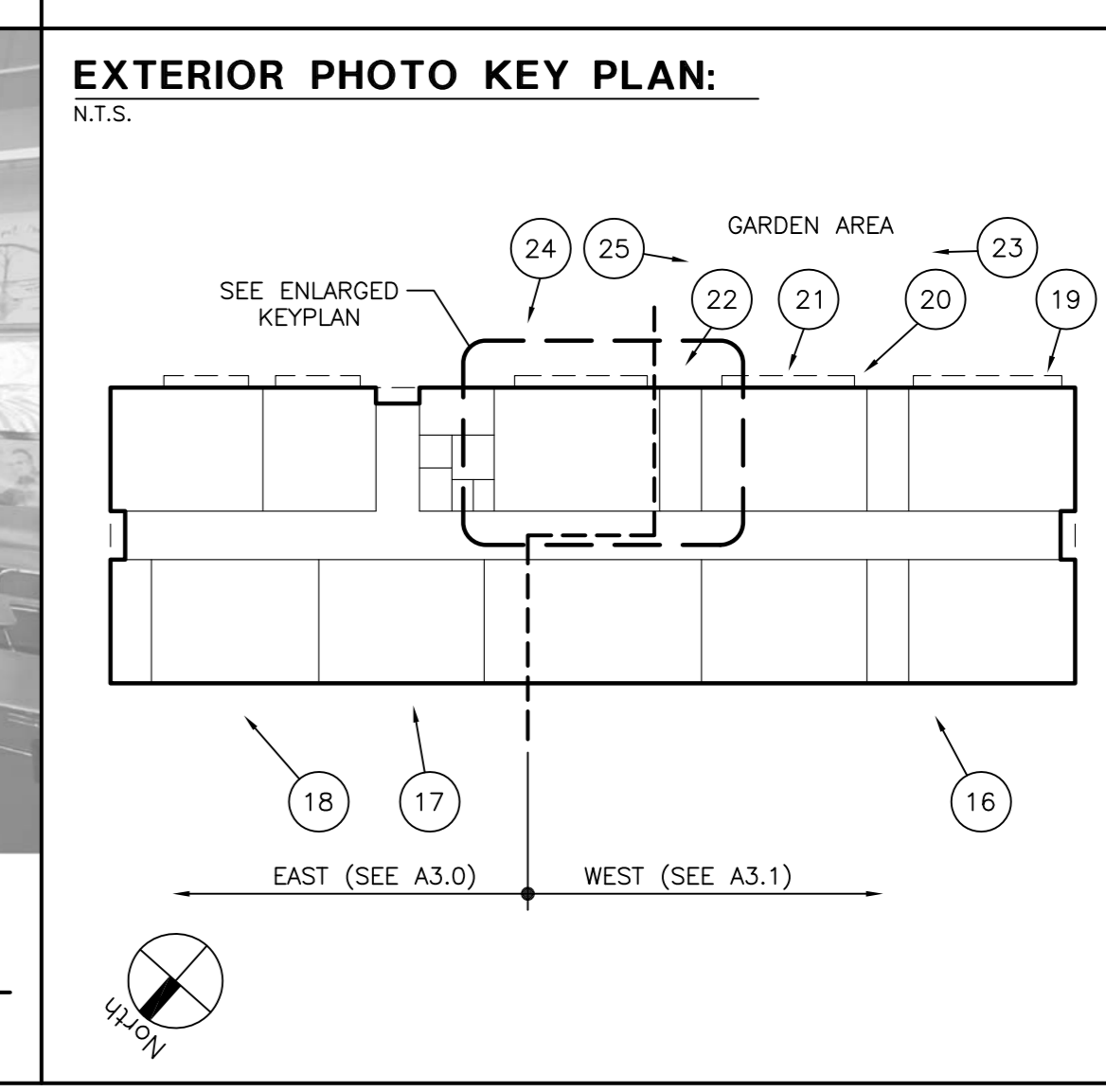

Mt. Diablo High School
Building S - Science Lab Modernization

2460 Grant Street
Concord, California 94520

Mt. Diablo Unified School District

MDUSD
MOUNT DIABLO UNIFIED SCHOOL DISTRICT

IDENTIFICATION STAMP
DIV. OF THE STATE ARCHITECT
OFFICE OF REGULATION SERVICES

APPLICATION NO. 01-
AC. FLS. SS.
DATE

DIVISION OF THE STATE ARCHITECT
revision date: by:

CONSULTANT

nacht&lewis
600 Q Street, Suite 100
Sacramento, CA 95811
www.nachtlewis.com
916.329.4000

ARCHITECT

REVISIONS

NO.	DESCRIPTION	DATE	REV'D

DATE February 19, 2012
JOB NO. Y1211.00
SHEET TITLE
Reference Photos

SHEET NO.
A8.2

SHEET ___ OF ___ TOTAL
DSA SUBMITTAL SET

ONE AND ONE-HALF INCH = ONE FOOT
 ONE INCH = ONE FOOT
 THREE-QUARTERS INCH = ONE FOOT
 ONE-HALF INCH = ONE FOOT
 ONE-QUARTER INCH = ONE FOOT
 ONE-EIGHTH INCH = ONE FOOT
 ONE-SIXTEENTH INCH = ONE FOOT
 ONE INCH = TWENTY FEET

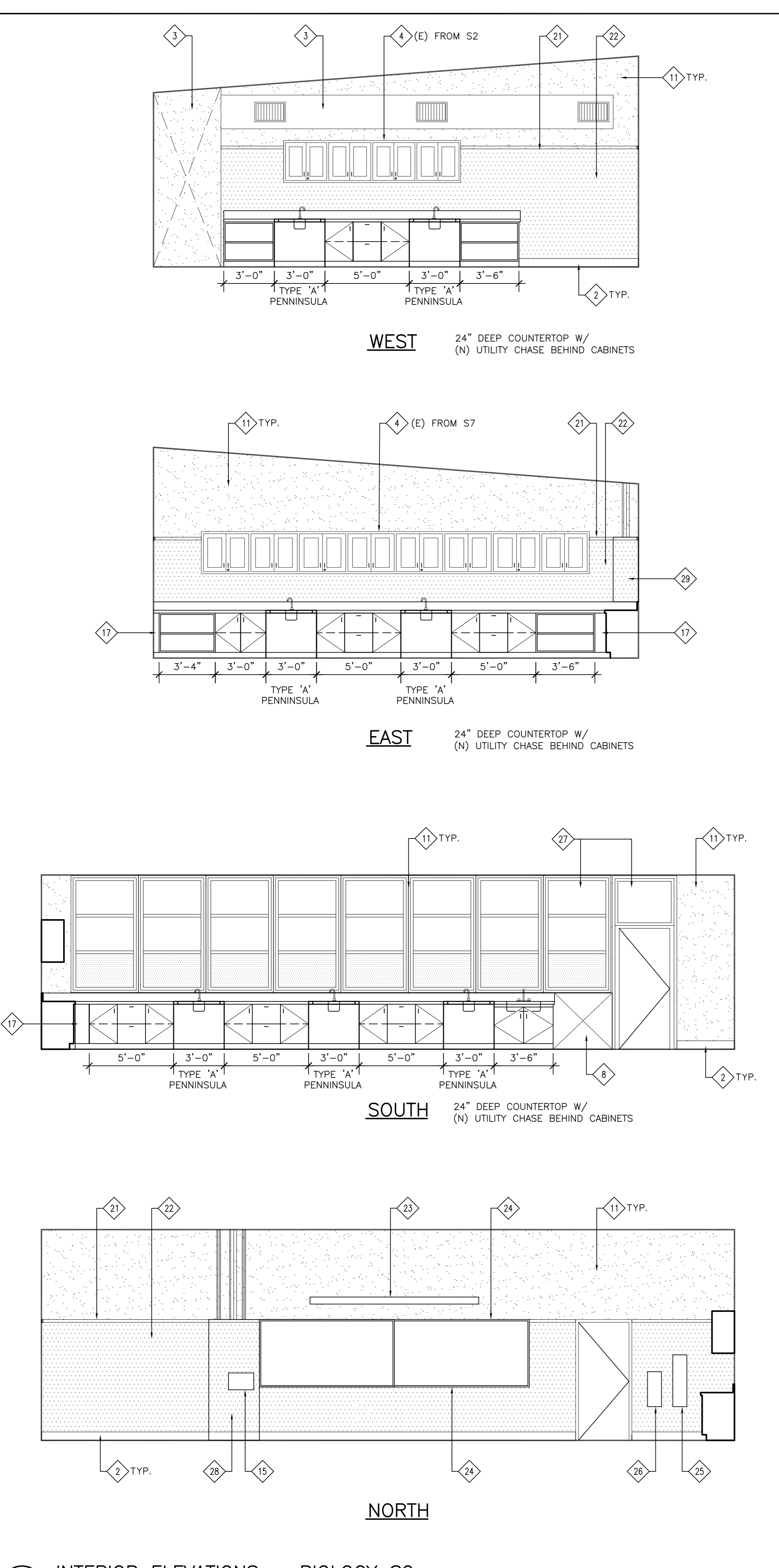

3 INTERIOR ELEVATIONS - BIOLOGY S2
SCALE: N.T.S.

- NEW WORK KEYNOTES:**
THESE NEW WORK NOTES APPLY TO THIS SHEET ONLY
- 1 EXISTING RELIEF AIR HOOD TO REMAIN
 - 2 RESILIENT BASE
 - 3 EXISTING HVAC SYSTEM TO REMAIN, U.O.N.
 - 4 REHANG (E) REFINISHED CABINETS AT LOCATIONS NOTED. NOTE INDICATES ORIGINAL ROOM NUMBER OF (E) CABINET TO BE REHUNG.
 - 5 NOT USED
 - 6 REFRIGERATOR (NIC)
 - 7 (E) HEATER TO BE REMOVED - PATCH AND REPAIR REMAINING WALL PENETRATIONS
 - 8 REMOVE (E) 1/4" AC PLYWOOD WALL PANEL AT EXPOSED WALL AREA AND REPLACE IN KIND WITH NEW PAINT
 - 9 INFILL OPENING(S) IN (E) WALL - TAPE AND TEXTURE TO MATCH (E). PAINT PER FINISH SCHEDULE
 - 10 REMOVE (E) TRANSFER GRILL - PATCH AND REPAIR OPENING
 - 11 PREP AND PAINT (E) WALL SURFACES AND WOOD WINDOW TRIM (WHERE OCCURS)
 - 12 REMOVE (E) TRANSFER GRILL - PATCH AND REPAIR OPENING
 - 13 BASE CABINET CONFIGURATION:
- PROVIDE NEW RESILIENT BASE.
 - 14 DOOR/OPENING WALL INFILL
 - 15 GAS SHUT-OFF VALVE WITH SURFACE MOUNTED GAS PIPING. SCRIBE VINYL TACK BOARD TIGHT TO PIPE AND VALVE BOX.
 - 16 PROVIDE SIDE SPLASH
 - 17 FILLER PANEL
 - 18 PLASTIC LAMINATE APRON - 27" MIN. CLR. TYP.
 - 19 PEG RACK - SEE SPEC SECTION 10 00 00.
 - 20 FUME HOOD BASE TOP CONFIGURATION:
- PROVIDE DISHED WORK SURFACE WITH LEFT FRONT CUP SINK, MODEL No. 20L17300 BY THERMO SCIENTIFIC HAMILTON OR EQUAL.
- PROVIDE POLYOLEFIN CUPSINK MODEL No. 34113700 BY THERMO SCIENTIFIC HAMILTON OR EQUAL.
- PROVIDE NEW RESILIENT BASE.
 - 21 NEW PAINTED WOOD TRIM - SEE DETAIL 25/AB.0
 - 22 NEW VINYL WRAPPED TACK PANEL
 - 23 NEW PROJECTION SCREEN - SEE 29/AB.0 FOR MOUNTING DETAIL, TYP
 - 24 NEW MARKER BOARD - SEE SPEC SECTION 10 11 00
 - 25 FIRE BLANKET
 - 26 FIRE EXTINGUISHER
 - 27 NEW EXTERIOR WINDOW SYSTEM
 - 28 FIRE EXTINGUISHER
 - 29 NEW EXTERIOR WINDOW SYSTEM
 - 30 NEW UTILITY CHASE TYPE "A" - SEE DETAIL 6/AB.0
 - 31 NEW UTILITY CHASE TYPE "B" - SEE DETAIL 7/AB.0

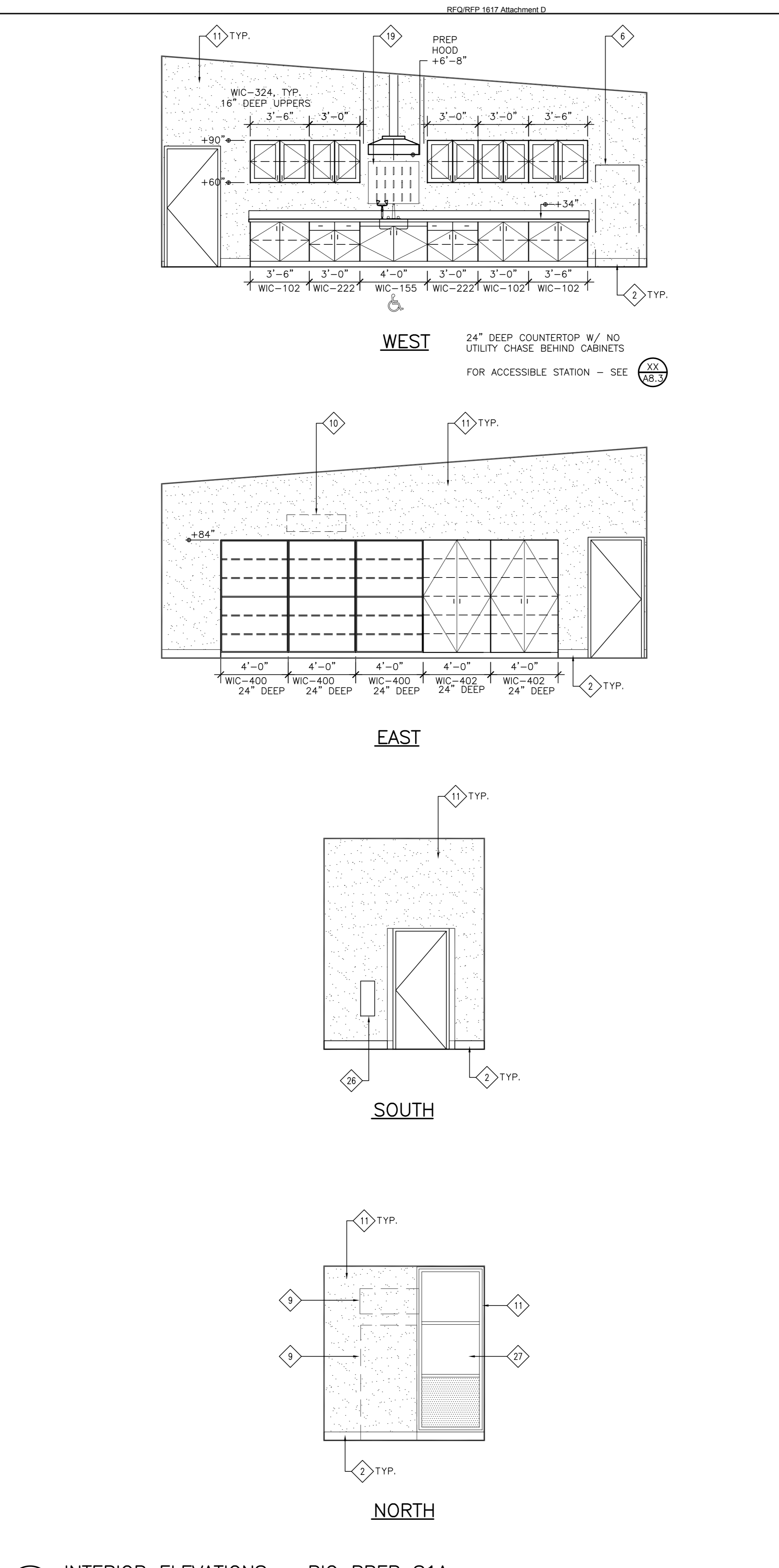

2 INTERIOR ELEVATIONS - BIO PREP S1A
SCALE: N.T.S.

- 10 REMOVE (E) TRANSFER GRILL - PATCH AND REPAIR OPENING
- 11 PREP AND PAINT (E) WALL SURFACES AND WOOD WINDOW TRIM (WHERE OCCURS)
- 12 REMOVE (E) TRANSFER GRILL - PATCH AND REPAIR OPENING
- 13 BASE CABINET CONFIGURATION:
- PROVIDE NEW RESILIENT BASE.
- 14 DOOR/OPENING WALL INFILL
- 15 GAS SHUT-OFF VALVE WITH SURFACE MOUNTED GAS PIPING. SCRIBE VINYL TACK BOARD TIGHT TO PIPE AND VALVE BOX.
- 16 PROVIDE SIDE SPLASH
- 17 FILLER PANEL
- 18 PLASTIC LAMINATE APRON - 27" MIN. CLR. TYP.
- 19 PEG RACK - SEE SPEC SECTION 10 00 00.
- 20 FUME HOOD BASE TOP CONFIGURATION:
- PROVIDE DISHED WORK SURFACE WITH LEFT FRONT CUP SINK, MODEL No. 20L17300 BY THERMO SCIENTIFIC HAMILTON OR EQUAL.
- PROVIDE POLYOLEFIN CUPSINK MODEL No. 34113700 BY THERMO SCIENTIFIC HAMILTON OR EQUAL.
- PROVIDE NEW RESILIENT BASE.
- 21 NEW PAINTED WOOD TRIM - SEE DETAIL 25/AB.0
- 22 NEW VINYL WRAPPED TACK PANEL
- 23 NEW PROJECTION SCREEN - SEE 29/AB.0 FOR MOUNTING DETAIL, TYP
- 24 NEW MARKER BOARD - SEE SPEC SECTION 10 11 00
- 25 FIRE BLANKET
- 26 FIRE EXTINGUISHER
- 27 NEW EXTERIOR WINDOW SYSTEM
- 28 FIRE EXTINGUISHER
- 29 NEW EXTERIOR WINDOW SYSTEM
- 30 NEW UTILITY CHASE TYPE "A" - SEE DETAIL 6/AB.0
- 31 NEW UTILITY CHASE TYPE "B" - SEE DETAIL 7/AB.0

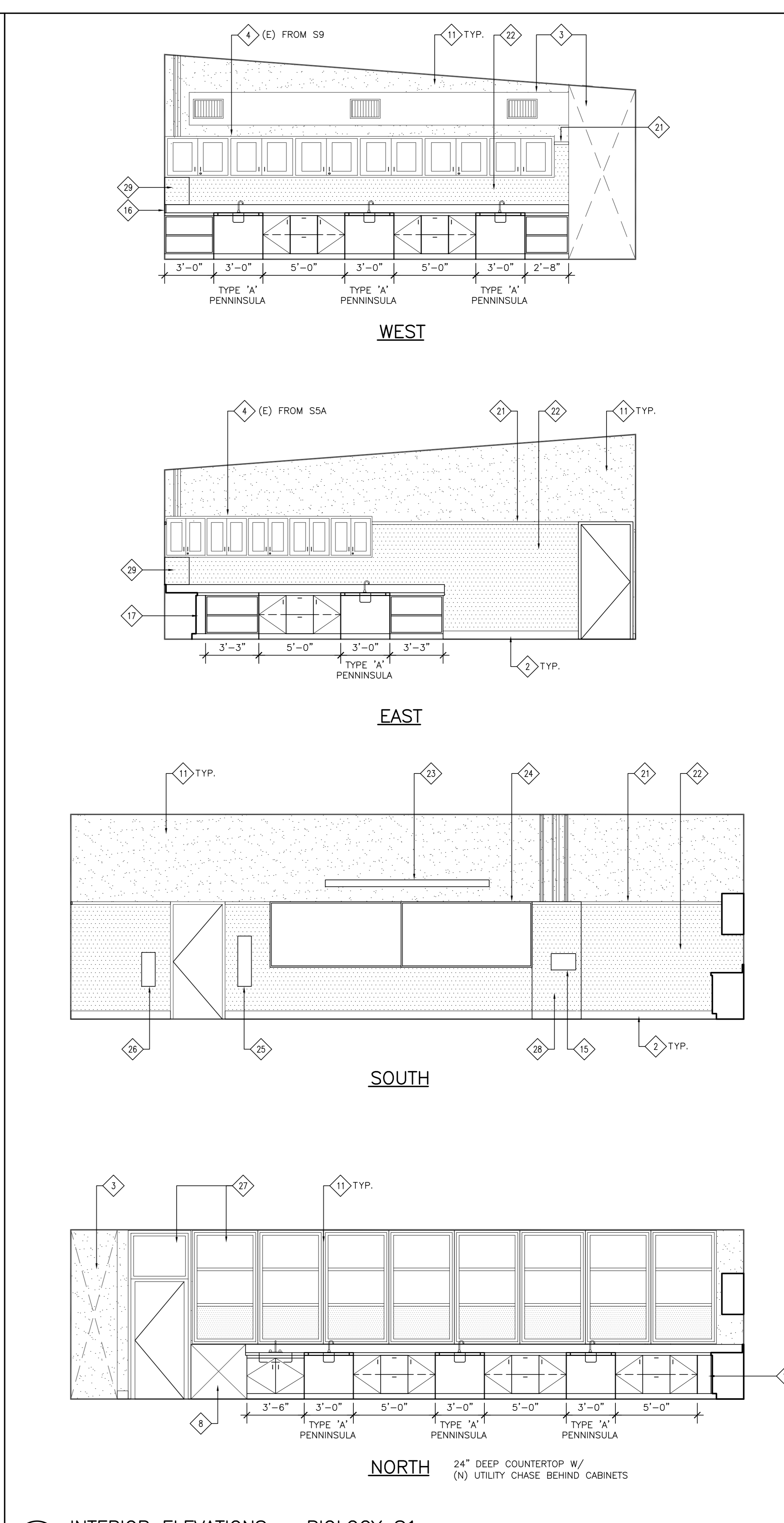

1 INTERIOR ELEVATIONS - BIOLOGY S1
SCALE: N.T.S.

- GENERAL NOTES**
1. CASEWORK MANUFACTURER SHALL NOTE ATTACHMENT DETAIL AND MAKE ACCOMMODATIONS FOR WALL LEDGERS AND SUB-TOP IN CASEWORK FABRICATION.
 2. AT ALL FREE-STANDING VERTICAL CASEWORK LEGS, PROVIDE (1) ANGLE CLIP SIMILAR TO DETAIL 3/AB.0 AT FRONT AND REAR OF LEG WITH 1/4" X 2" EXPANSION BOLT INTO CONCRETE FLOORING.
 3. AT ALL LOCATIONS WHERE NEW CABINET COUNTERTOPS DO NOT ALIGN WITH EXISTING COUNTERTOPS, PROVIDE VERTICAL TRANSITION COUNTERTOP PIECE.
 4. SEE FLOOR PLANS AND FINISH SCHEDULE FOR ITEMS NOT SHOWN ON ELEVATIONS.
 5. SEE DETAIL 26 FOR EQUIPMENT MOUNTING HEIGHTS. SEE FLOOR AB.3 PLANS FOR LOCATIONS.
 6. SEE SHEET AB.0 FOR CASEWORK DETAILS.
 7. PAINT ALL EXPOSED INTERIOR WALL AND WINDOW TRIM SURFACES THROUGHOUT ALL LABS AND WORKROOMS. PATCH AND REPAIR SURFACES PRIOR TO PAINT.
 8. ALL FINISH KEYNOTES INDICATED HERE SHALL BE CONSIDERED TYPICAL THROUGHOUT FOR SIMILAR CONDITIONS IF SHOWN OR NOT OTHERWISE NOTED. SEE FINISH SCHEDULE FOR ADDITIONAL FINISH INFORMATION THAT MAY NOT BE SHOWN HERE.
 9. WHERE NEW VINYL WRAPPED TACK PANELS OCCUR, ALL NEW EQUIPMENT ITEMS SHALL BE SURFACE MOUNTED OVER NEW PANELS.
 10. AT ALL EXISTING UPPER CABINETS SHOWN TO BE REINSTALLED: CLEAN ALL SURFACES WITH MILD SOLUTION OF TSP. SAND/SCUFF ALL SURFACES OF EXTERIOR BODY OF CABINETS AND PROVIDE A CLEAR SATIN SEALER. INTERIOR OF CABINET SHALL REMAIN AS IS.
 11. AT ALL EXISTING UPPER CABINETS SHOWN TO BE REINSTALLED: REPLACE ALL EXTERIOR PULLS WITH SAME TYPE BEING USED ON NEW CASEWORK.
 12. AT ALL EXISTING UPPER CABINETS SHOWN TO BE REINSTALLED: REPLACE ALL CYLINDER LOCKS WITH NEW TO MATCH NEW CASEWORK LOCKS.
 13. ALL NEW CASEWORK DRAWERS AND DOORS SHALL HAVE PULLS & LOCKS PER SPECIFICATION SECTION 06 41 16.

MDUSD
 Mt. Diablo High School
 Building S - Science Lab Modernization
 2460 Grant Street
 Concord, California 94520
MDUSD
 DIVISION OF THE STATE ARCHITECT
 OFFICE OF REGULATION SERVICES
 APPLICATION NO. 01-
 AC. FLS. SS
 DATE
 DIVISION OF THE STATE ARCHITECT
 revision date: by:
 CONSULTANT
nacht&lewis
 600 Q Street, Suite 100
 Sacramento, CA 95811
 www.nachtlewis.com
 916.329.4000
ARCHITECT
REVISIONS

NO.	DESCRIPTION	DATE	REV'D

 DATE February 19, 2012
 JOB NO. Y1211.00
 SHEET TITLE
**Interior Elevations/
 Casework
 Details**
 SHEET NO.
A9.1
 SHEET ___ OF ___ TOTAL
DSA SUBMITTAL SET

ONE AND ONE-HALF INCH = ONE FOOT
 ONE INCH = ONE FOOT
 THREE-QUARTERS INCH = ONE FOOT
 ONE-HALF INCH = ONE FOOT
 ONE-QUARTER INCH = ONE FOOT
 ONE-EIGHTH INCH = ONE FOOT
 ONE-SIXTEENTH INCH = ONE FOOT
 ONE INCH = TWENTY FEET

REF: REP. 1617 Attachment D

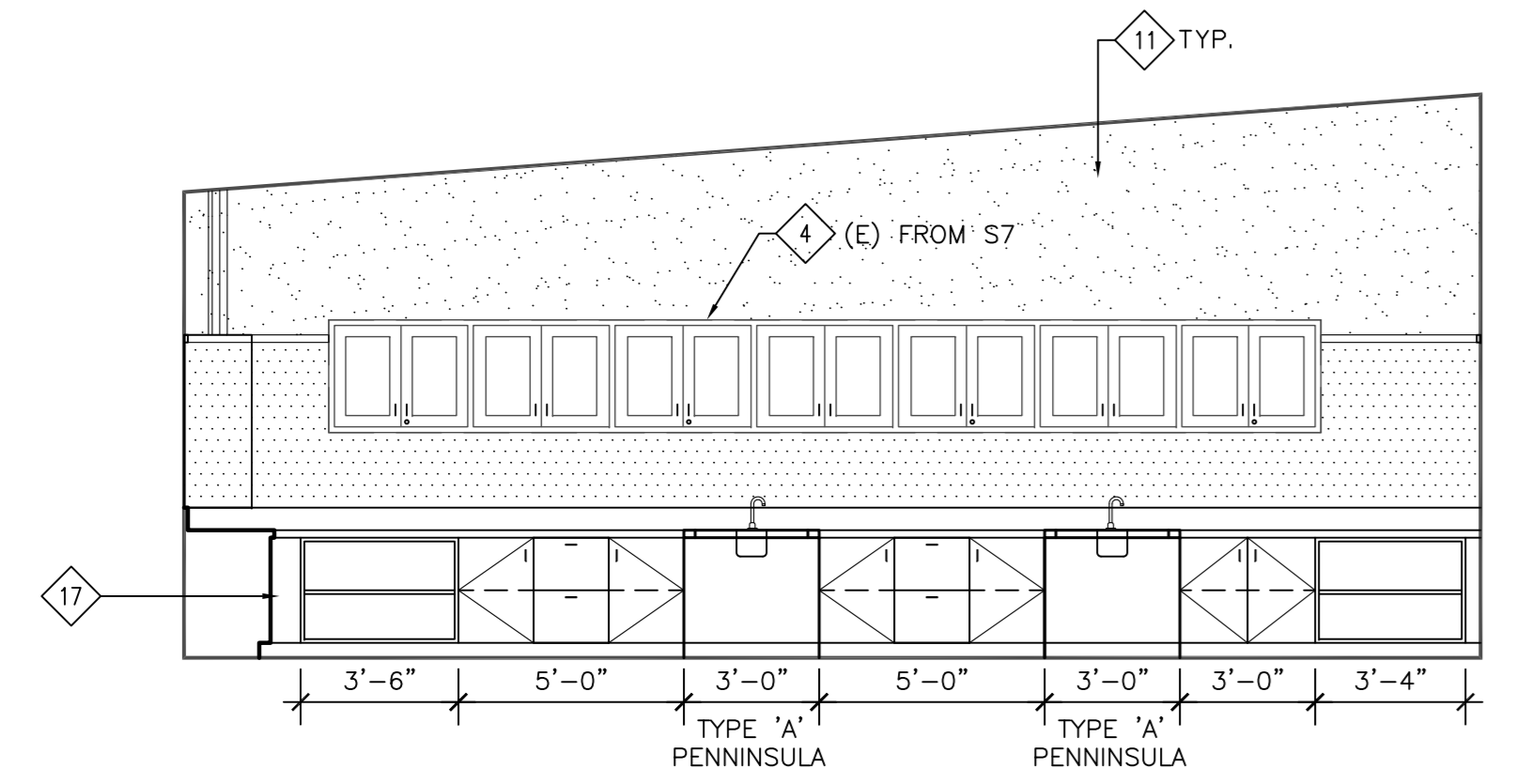

WEST 24" DEEP COUNTERTOP W/
(N) UTILITY CHASE BEHIND CABINETS

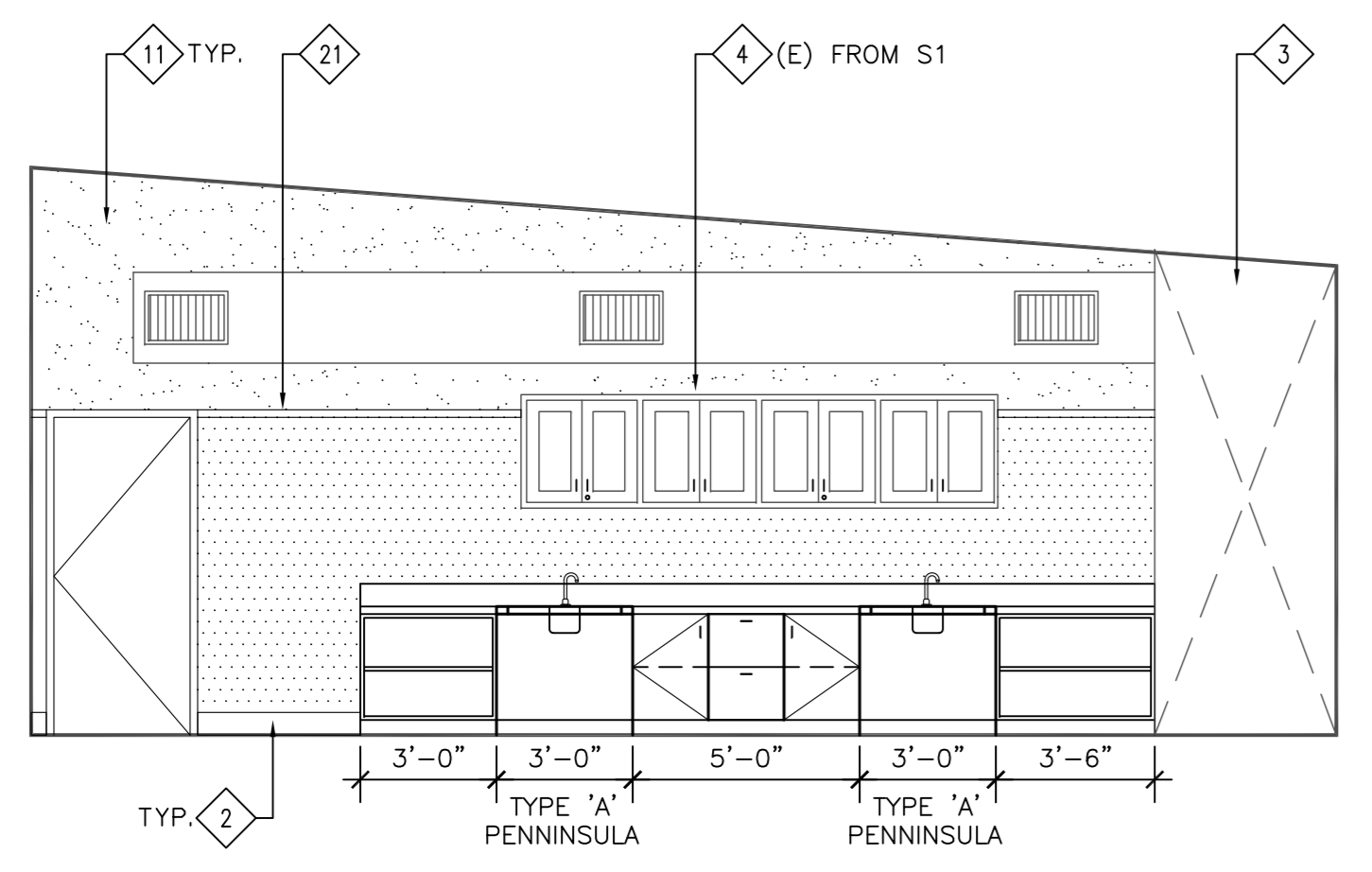

EAST 24" DEEP COUNTERTOP W/
(N) UTILITY CHASE BEHIND CABINETS

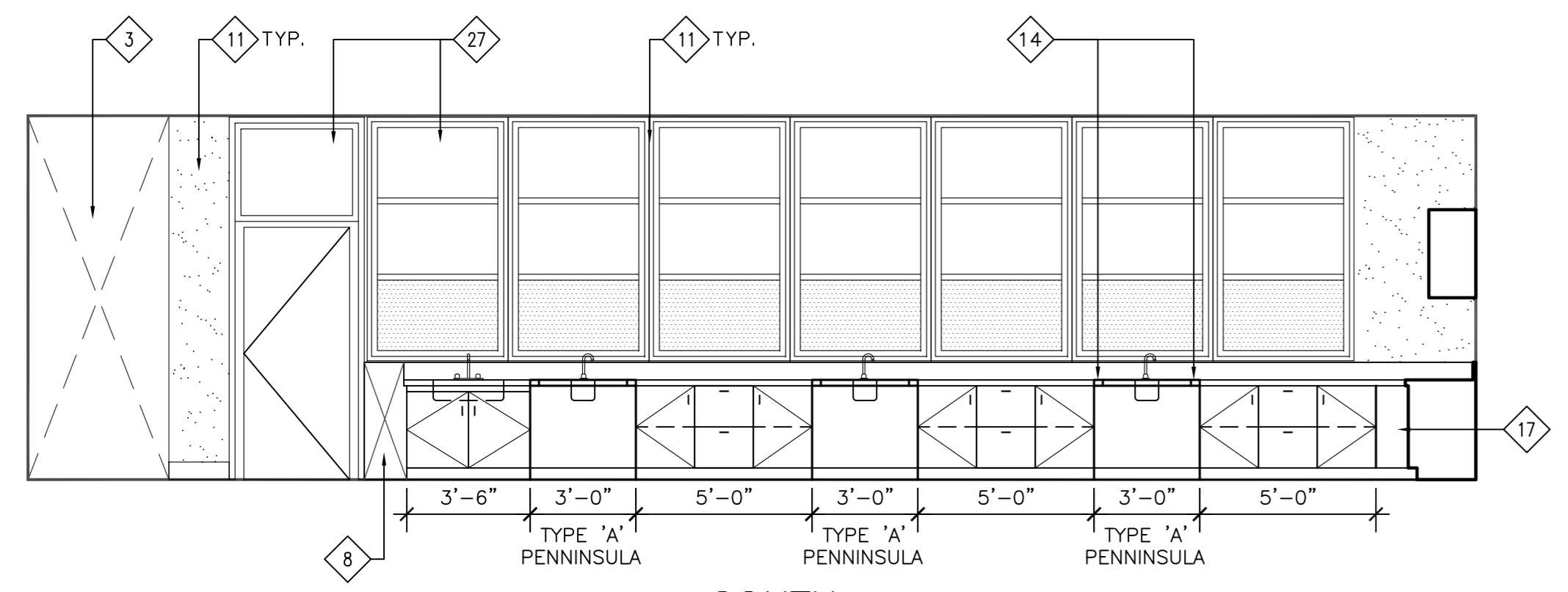

SOUTH

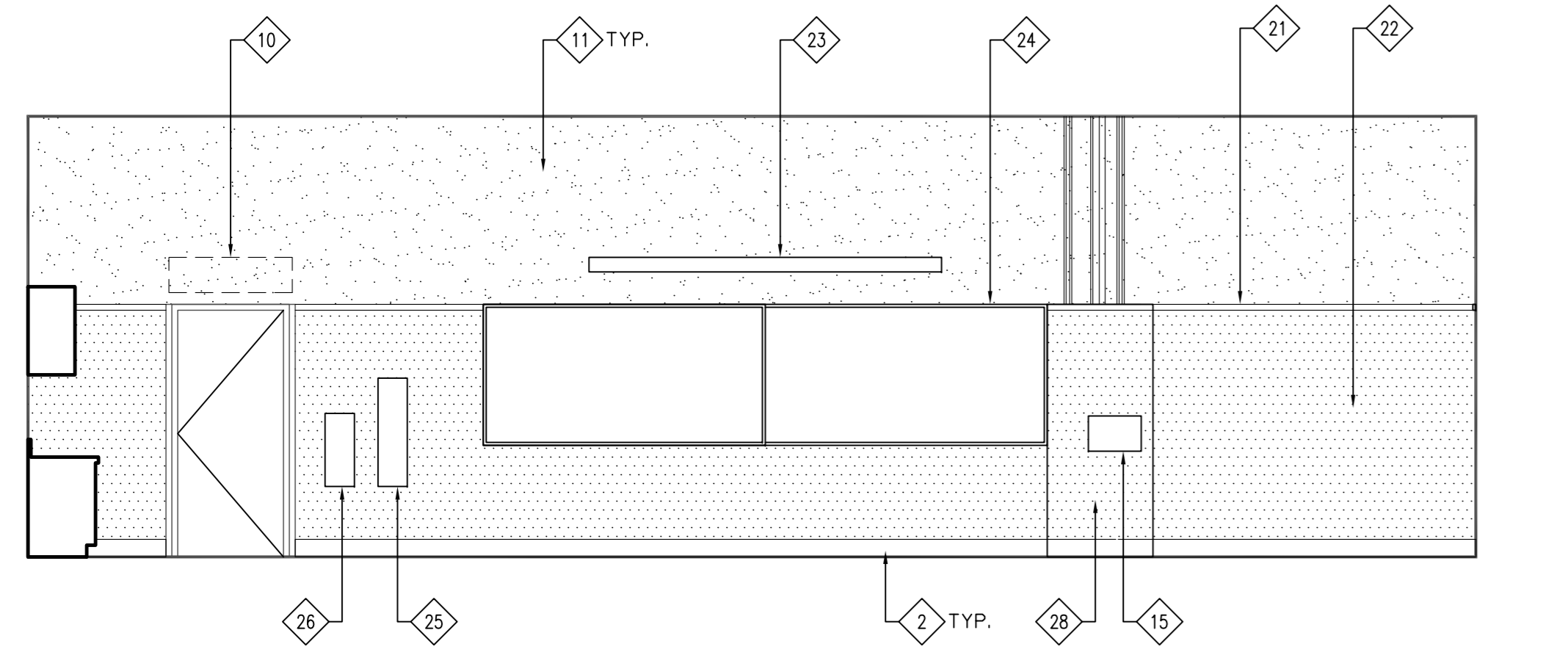

NORTH

3 INTERIOR ELEVATION - EARTH SCIENCE S4
SCALE: N.T.S.

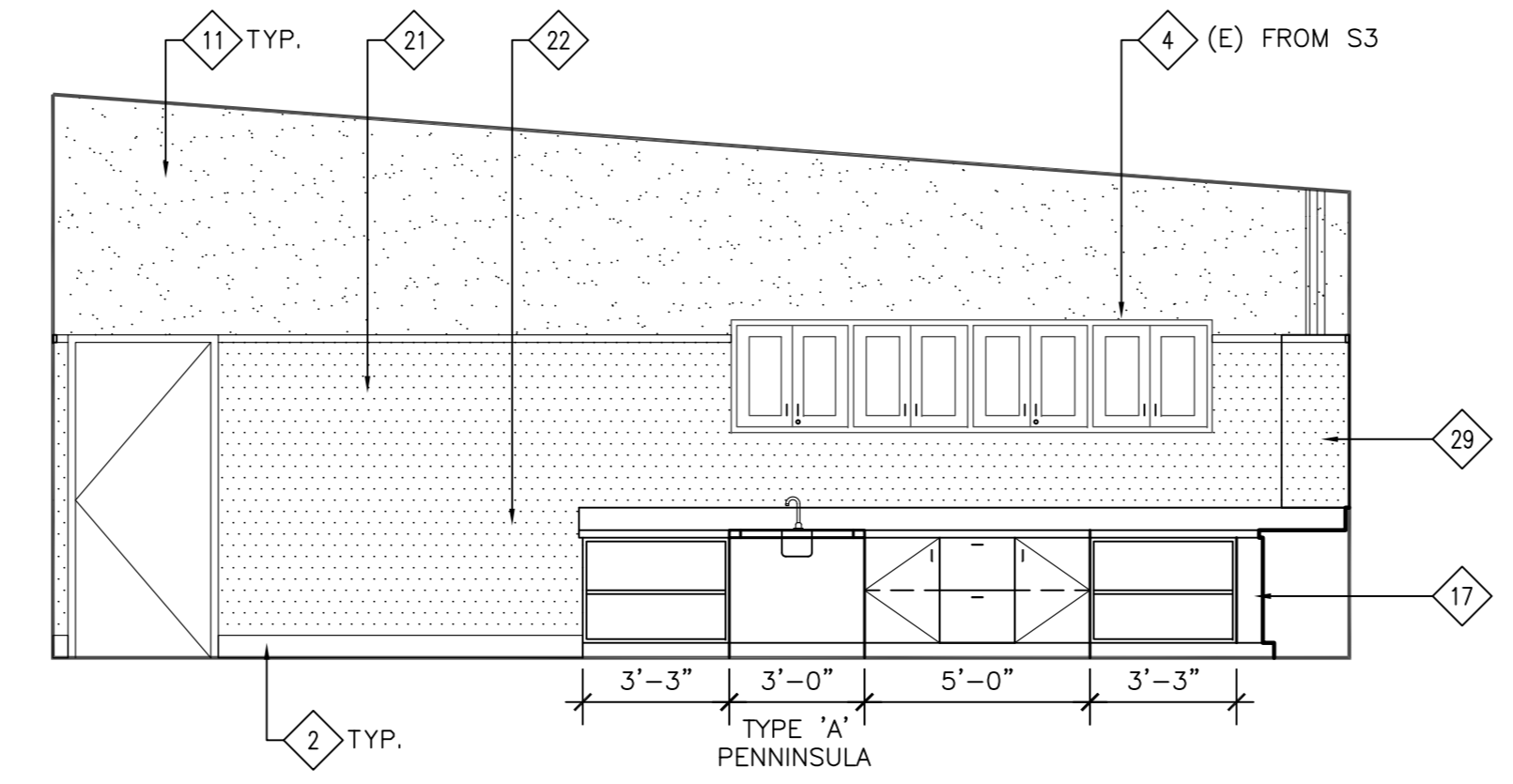

WEST 24" DEEP COUNTERTOP W/
(N) UTILITY CHASE BEHIND CABINETS

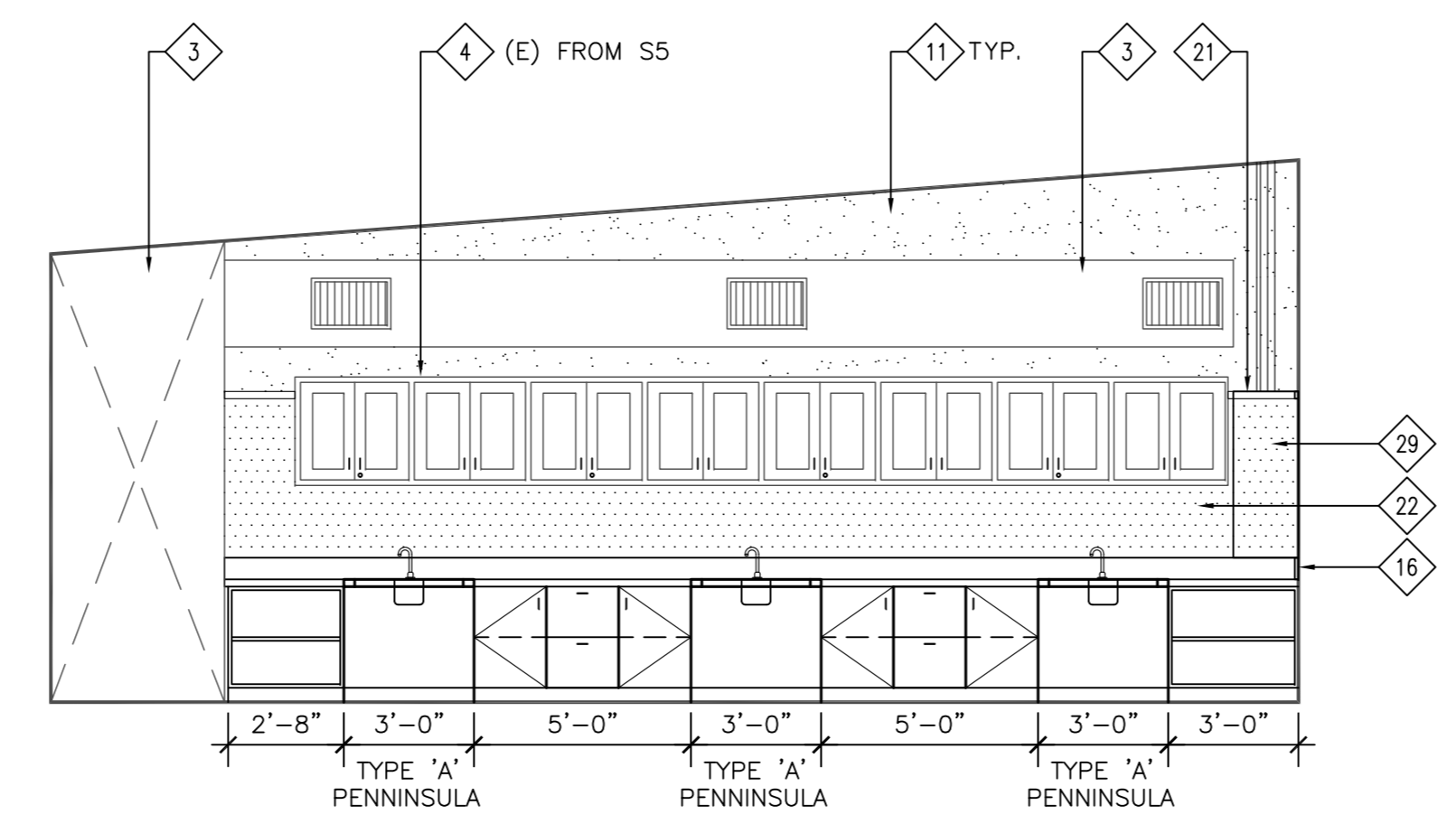

EAST 24" DEEP COUNTERTOP W/
(N) UTILITY CHASE BEHIND CABINETS

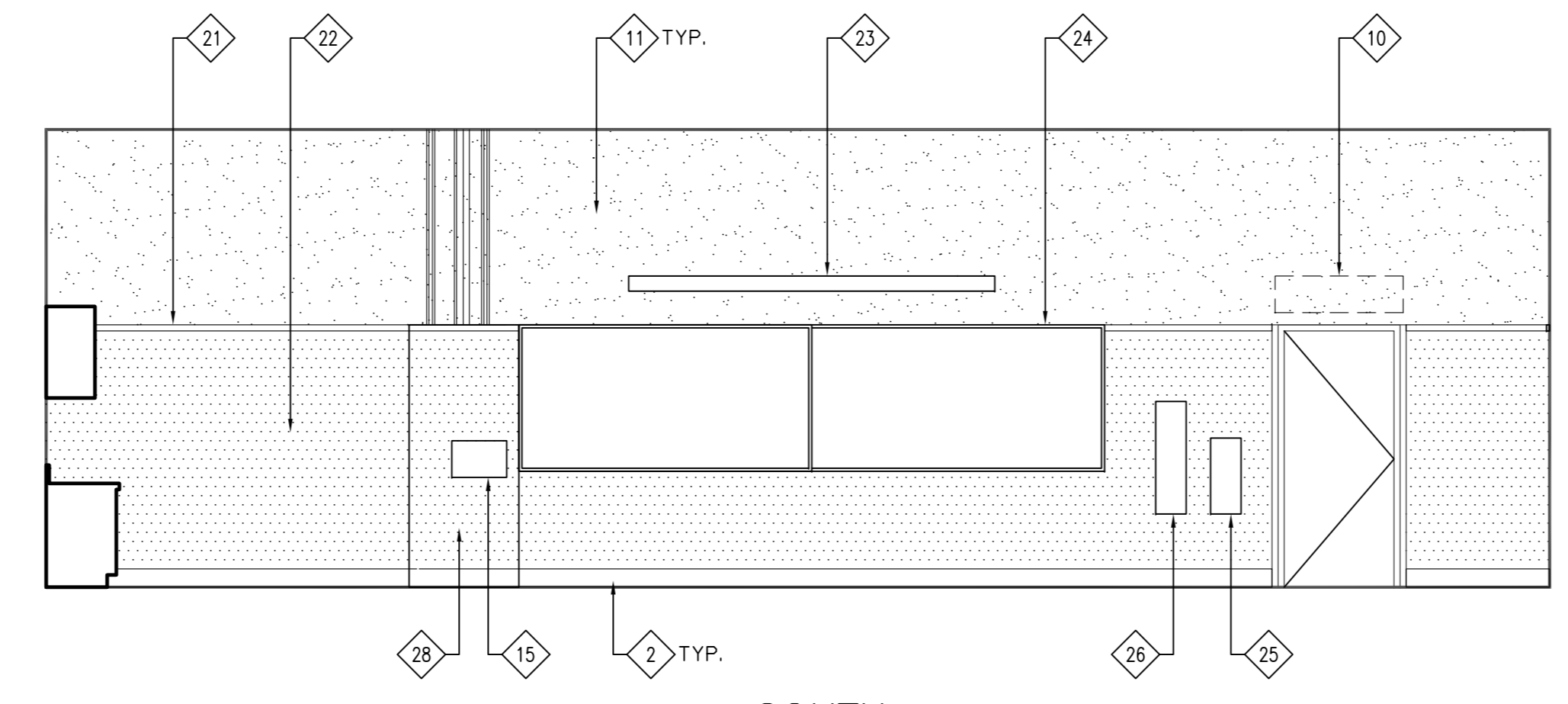

SOUTH

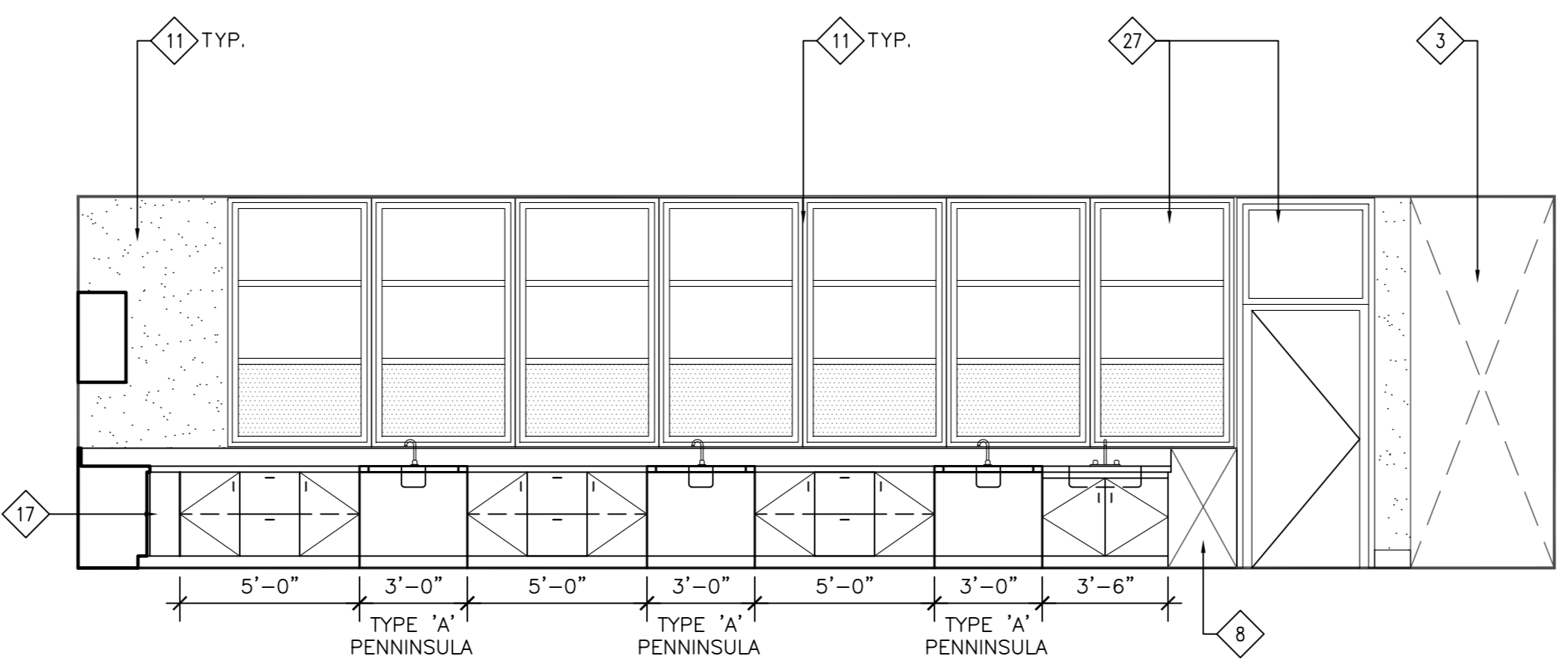

NORTH 24" DEEP COUNTERTOP W/
(N) UTILITY CHASE BEHIND CABINETS

2 INTERIOR ELEVATION - BIOLOGY S3
SCALE: N.T.S.

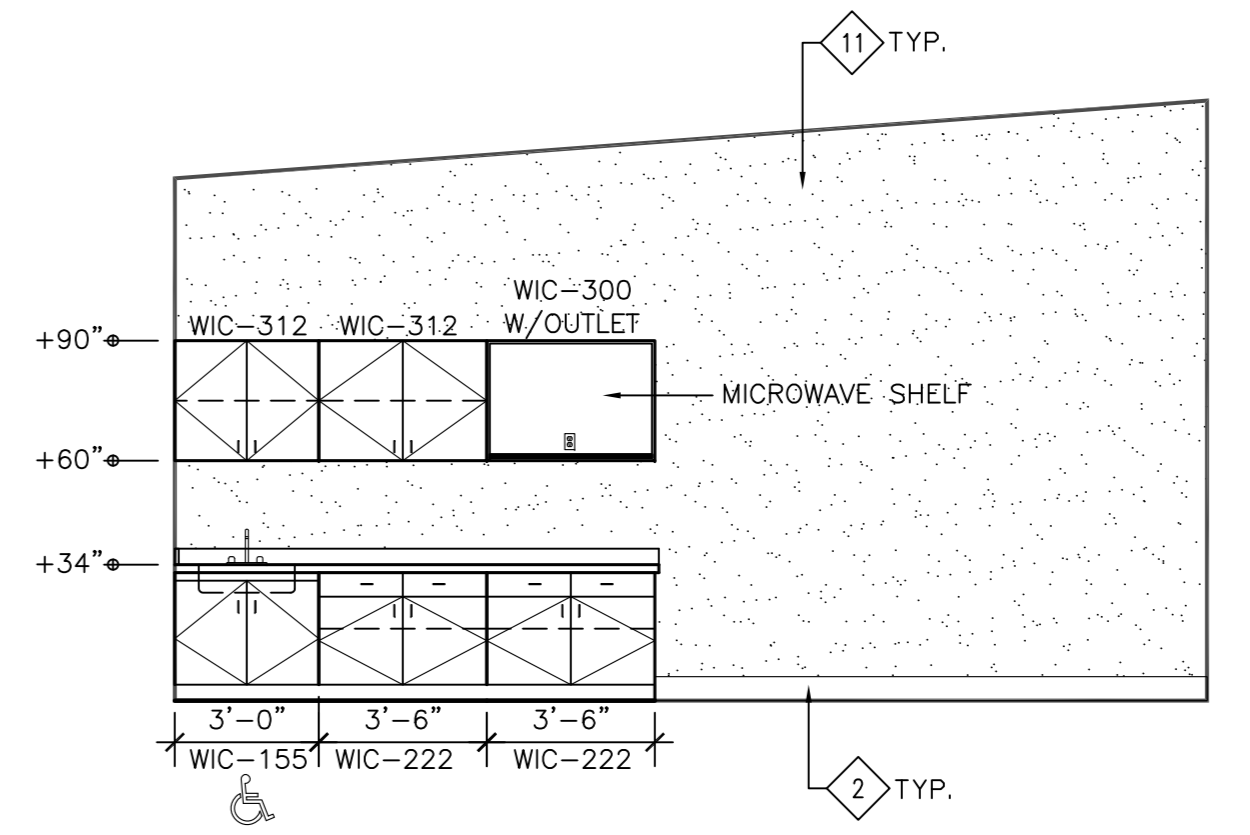

WEST FOR ACCESSIBLE STATION - SEE XX
XX

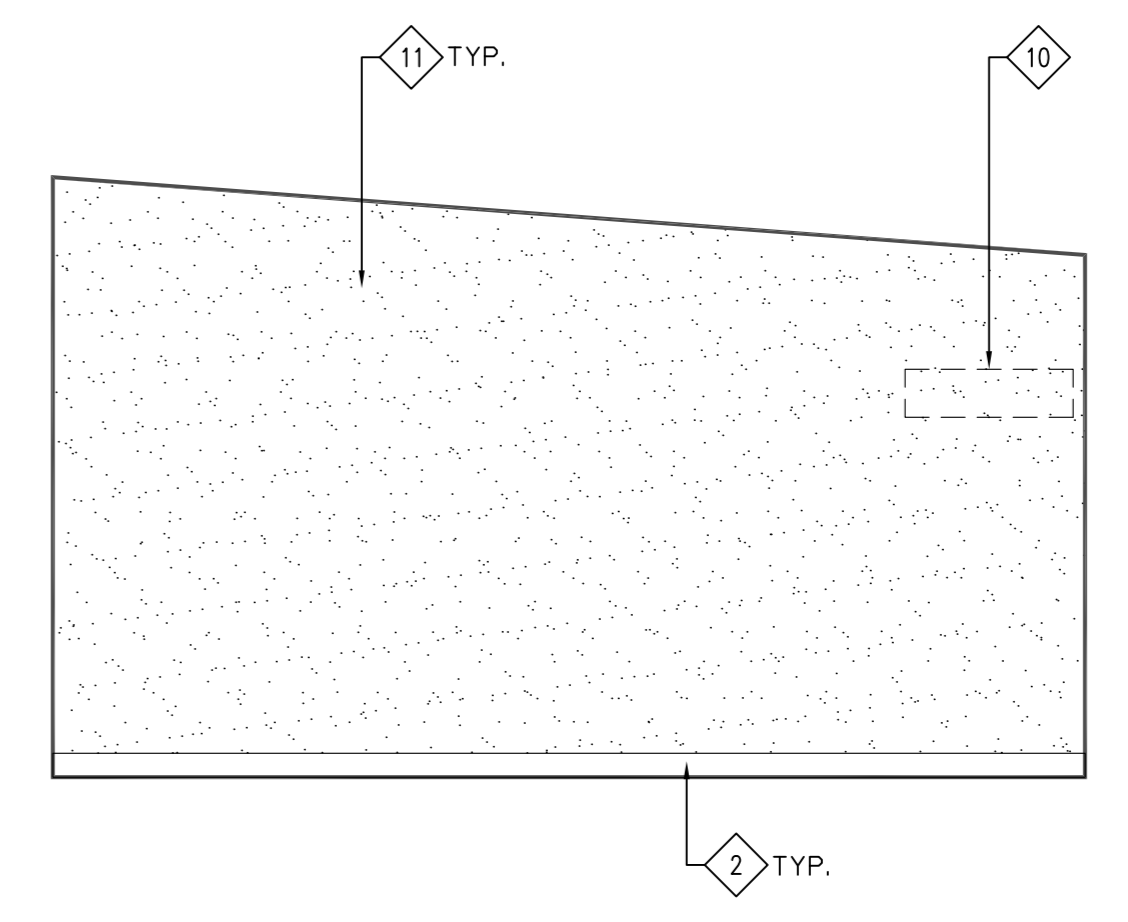

EAST

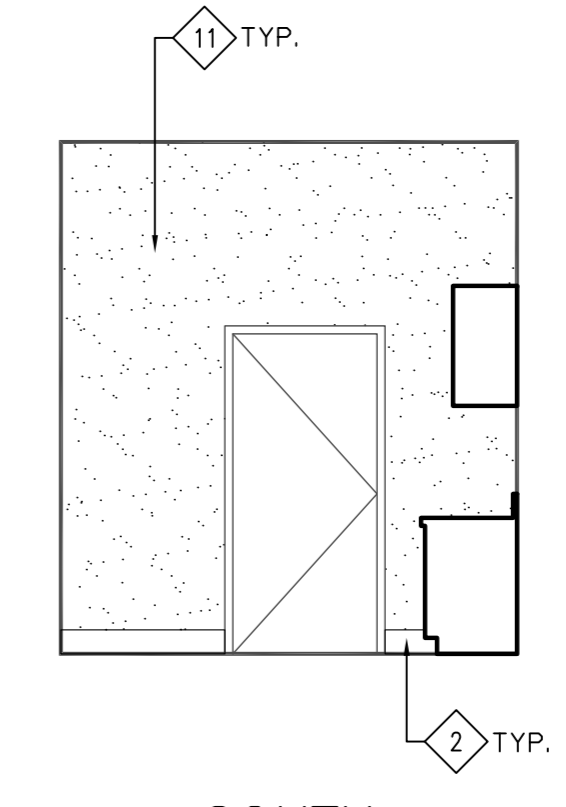

SOUTH

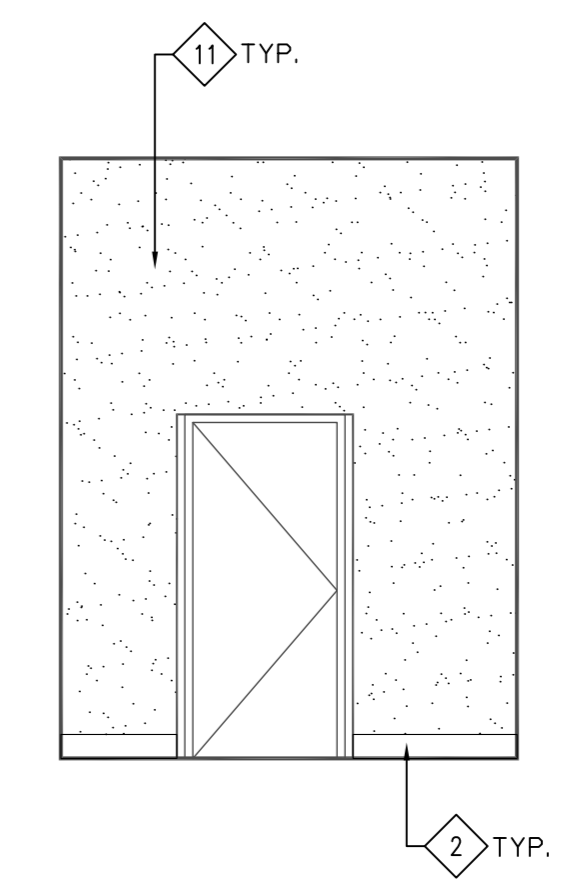

NORTH

1 INTERIOR ELEVATION - WORKROOM S2A
SCALE: N.T.S.

NEW WORK KEYNOTES:

THESE NEW WORK NOTES APPLY TO THIS SHEET ONLY

- 1 EXISTING RELIEF AIR HOOD TO REMAIN
- 2 RESILIENT BASE
- 3 EXISTING HVAC SYSTEM TO REMAIN, U.O.N.
- 4 REHANG (E) REFINISHED CABINETS AT LOCATIONS NOTED. NOTE INDICATES ORIGINAL ROOM NUMBER OF (E) CABINET TO BE REHUNG.
- 5 NOT USED
- 6 REFRIGERATOR (NIC)
- 7 (E) HEATER TO BE REMOVED - PATCH AND REPAIR REMAINING WALL PENETRATIONS
- 8 REMOVE (E) 1/4" AC PLYWOOD WALL PANEL AT EXPOSED WALL AREA AND REPLACE IN KIND WITH NEW PAINT
- 9 INFILL OPENING(S) IN (E) WALL - TAPE AND TEXTURE TO MATCH (E). PAINT PER FINISH SCHEDULE
- 10 REMOVE (E) TRANSFER GRILL - PATCH AND REPAIR OPENING
- 11 PREP AND PAINT (E) WALL SURFACES AND WOOD WINDOW TRIM (WHERE OCCURS)
- 12 REMOVE (E) TRANSFER GRILL - PATCH AND REPAIR OPENING
- 13 BASE CABINET CONFIGURATION - PROVIDE NEW RESILIENT BASE.
- 14 DOOR/OPENING WALL INFILL
- 15 GAS SHUT-OFF VALVE WITH SURFACE MOUNTED GAS PIPING. SCRIBE VINYL TACK BOARD TIGHT TO PIPE AND VALVE BOX.
- 16 PROVIDE SIDE SPLASH

- 17 FILLER PANEL
- 18 PLASTIC LAMINATE APRON - 27" MIN. CLR. TYP.
- 19 PEG RACK - SEE SPEC SECTION 10 00 00.
- 20 FUME HOOD BASE TOP CONFIGURATION: - PROVIDE DISHED WORK SURFACE WITH LEFT FRONT CLIP SINK, MODEL No. 20L17300 BY THERMO SCIENTIFIC HAMILTON OR EQUAL. - PROVIDE POLYOLEFIN CUPSINK MODEL No. 34113700 BY THERMO SCIENTIFIC HAMILTON OR EQUAL. - PROVIDE NEW RESILIENT BASE.
- 21 NEW PAINTED WOOD TRIM - SEE DETAIL 25/28.0
- 22 NEW VINYL WRAPPED TACK PANEL
- 23 NEW PROJECTION SCREEN - SEE 29/28.0 FOR MOUNTING DETAIL, TYP
- 24 NEW MARKER BOARD - SEE SPEC SECTION 10 11 00

- 25 FIRE BLANKET
- 26 FIRE EXTINGUISHER
- 27 NEW EXTERIOR WINDOW SYSTEM
- 28 FIRE EXTINGUISHER
- 27 NEW EXTERIOR WINDOW SYSTEM
- 28 NEW UTILITY CHASE TYPE "A" - SEE DETAIL 6/28.0
- 29 NEW UTILITY CHASE TYPE "B" - SEE DETAIL 7/28.0

GENERAL NOTES

1. CASEWORK MANUFACTURER SHALL NOTE ATTACHMENT DETAIL AND MAKE ACCOMMODATIONS FOR WALL LEDGERS AND SUB-TOP IN CASEWORK FABRICATION.
2. AT ALL FREE-STANDING VERTICAL CASEWORK LEGS, PROVIDE (1) ANGLE CLIP SIMILAR TO DETAIL 3/28.0 AT FRONT AND REAR OF LEG WITH 1/4" X 2" EXPANSION BOLT INTO CONCRETE FLOORING.
3. AT ALL LOCATIONS WHERE NEW CABINET COUNTERTOPS DO NOT ALIGN WITH EXISTING COUNTERTOPS, PROVIDE VERTICAL TRANSITION COUNTERTOP PIECE.
4. SEE FLOOR PLANS AND FINISH SCHEDULE FOR ITEMS NOT NOTED ON ELEVATIONS.
5. SEE DETAIL 26 FOR EQUIPMENT MOUNTING HEIGHTS. SEE FLOOR 26.3 PLANS FOR LOCATIONS.
6. SEE SHEET 28.0 FOR CASEWORK DETAILS.
7. PAINT ALL EXPOSED INTERIOR WALL AND WINDOW TRIM SURFACES THROUGHOUT ALL LABS AND WORKROOMS. PATCH AND REPAIR SURFACES PRIOR TO PAINT.
8. ALL FINISH KEYNOTES INDICATED HERE SHALL BE CONSIDERED TYPICAL THROUGHOUT FOR SIMILAR CONDITIONS IF SHOWN OR NOT OTHERWISE NOTED. SEE FINISH SCHEDULE FOR ADDITIONAL FINISH INFORMATION THAT MAY NOT BE SHOWN HERE.
9. WHERE NEW VINYL WRAPPED TACK PANELS OCCUR, ALL NEW EQUIPMENT ITEMS SHALL BE SURFACE MOUNTED OVER NEW PANELS.
10. AT ALL EXISTING UPPER CABINETS SHOWN TO BE REINSTALLED: CLEAN ALL SURFACES WITH MILD SOLUTION OF TSP. SAND/SCUFF ALL SURFACES OF EXTERIOR BODY OF CABINETS AND PROVIDE A CLEAR SATIN SEALER. INTERIOR OF CABINET SHALL REMAIN AS IS.
11. AT ALL EXISTING UPPER CABINETS SHOWN TO BE REINSTALLED: REPLACE ALL CYLINDER LOCKS WITH SAME TYPE BEING USED ON NEW CASEWORK.
12. AT ALL EXISTING UPPER CABINETS SHOWN TO BE REINSTALLED: REPLACE ALL CYLINDER LOCKS WITH NEW TO MATCH NEW CASEWORK LOCKS.
13. ALL NEW CASEWORK DRAWERS AND DOORS SHALL HAVE PULLS & LOCKS PER SPECIFICATION SECTION 06 41 16.

Mt. Diablo High School
Building S - Science Lab Modernization
 2460 Grant Street
 Concord, California 94520
Mt. Diablo Unified School District



FILE NO. XX-XX
 IDENTIFICATION STAMP
 DIV. OF THE STATE ARCHITECT
 OFFICE OF REGULATION SERVICES
 APPLICATION NO. 01-
 AC. FLS. SS.
 DATE

DIVISION OF THE STATE ARCHITECT
 revision date: by:

CONSULTANT
nacht&lewis
 600 O Street, Suite 100
 Sacramento, CA 95811
 www.nachtlewis.com
 916.329.4000

ARCHITECT

REVISIONS		
NO.	DESCRIPTION	DATE / REV

DATE February 19, 2012
 JOB NO. Y1211.00
 SHEET TITLE
**Interior Elevations/
 Casework
 Details**
 SHEET NO.
A9.2
 SHEET ___ OF ___ TOTAL
 DSA SUBMITTAL SET

ONE AND ONE-HALF INCH = ONE FOOT
 ONE INCH = ONE FOOT
 THREE-QUARTERS INCH = ONE FOOT
 ONE-HALF INCH = ONE FOOT
 ONE-QUARTER INCH = ONE FOOT
 ONE-EIGHTH INCH = ONE FOOT
 ONE-SIXTEENTH INCH = ONE FOOT
 ONE INCH = TWENTY FEET

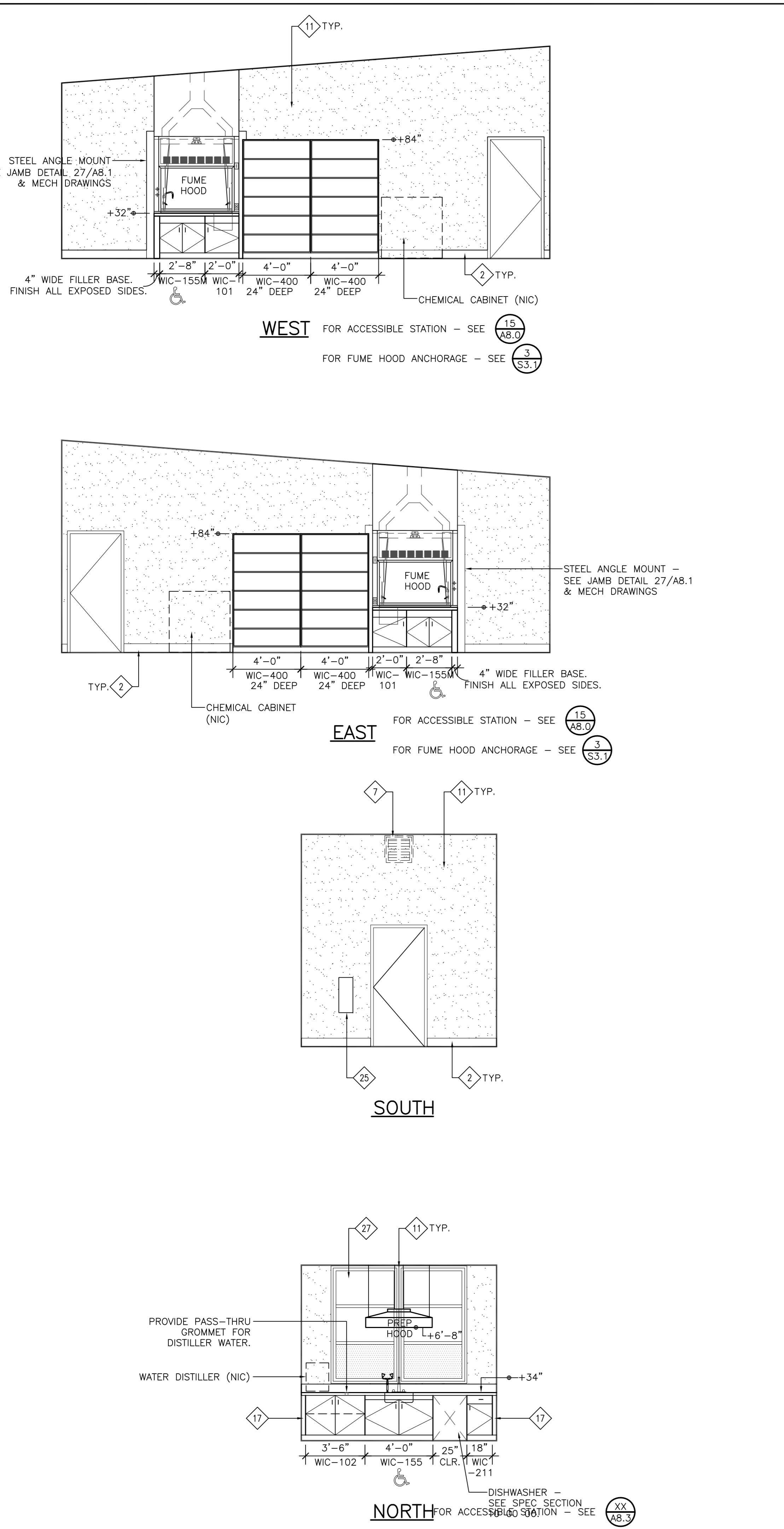

3 INTERIOR ELEVATION - CHEM/BIO PREP S5A
SCALE: N.T.S.

- NEW WORK KEYNOTES:**
THESE NEW WORK NOTES APPLY TO THIS SHEET ONLY
- 1 EXISTING RELIEF AIR HOOD TO REMAIN
 - 2 RESILIENT BASE
 - 3 EXISTING HVAC SYSTEM TO REMAIN, U.O.N.
 - 4 REHANG (E) REFINISHED CABINETS AT LOCATIONS NOTED. NOTE INDICATES ORIGINAL ROOM NUMBER OF (E) CABINET TO BE REHUNG.
 - 5 NOT USED
 - 6 REFRIGERATOR (NIC)
 - 7 (E) HEATER TO BE REMOVED - PATCH AND REPAIR REMAINING WALL PENETRATIONS
 - 8 REMOVE (E) 1/4" AC PLYWOOD WALL PANEL AT EXPOSED WALL AREA AND REPLACE IN KIND WITH NEW PAINT
 - 9 INFILL OPENING(S) IN (E) WALL - TAPE AND TEXTURE TO MATCH (E). PAINT PER FINISH SCHEDULE
 - 10 REMOVE (E) TRANSFER GRILL - PATCH AND REPAIR OPENING
 - 11 PREP AND PAINT (E) WALL SURFACES AND WOOD WINDOW TRIM (WHERE OCCURS)
 - 12 REMOVE (E) TRANSFER GRILL - PATCH AND REPAIR OPENING
 - 13 BASE CABINET CONFIGURATION: - PROVIDE NEW RESILIENT BASE.
 - 14 DOOR/OPENING WALL INFILL
 - 15 GAS SHUT-OFF VALVE WITH SURFACE MOUNTED GAS PIPING. SCRIBE VINYL TACK BOARD TIGHT TO PIPE AND VALVE BOX.
 - 16 PROVIDE SIDE SPLASH
 - 17 FILLER PANEL
 - 18 PLASTIC LAMINATE APRON - 27" MIN. CLR. TYP.
 - 19 PEG RACK - SEE SPEC SECTION 10 00 00.
 - 20 FUME HOOD BASE TOP CONFIGURATION: - PROVIDE DISHED WORK SURFACE WITH LEFT FRONT CLIP SINK, MODEL No. 20L17300 BY THERMO SCIENTIFIC HAMILTON OR EQUAL. - PROVIDE POLYOLEFIN CUPSINK MODEL No. 34113700 BY THERMO SCIENTIFIC HAMILTON OR EQUAL. - PROVIDE NEW RESILIENT BASE.
 - 21 NEW PAINTED WOOD TRIM - SEE DETAIL 25/AB.0
 - 22 NEW VINYL WRAPPED TACK PANEL
 - 23 NEW PROJECTION SCREEN - SEE 29/AB.0 FOR MOUNTING DETAIL, TYP
 - 24 NEW MARKER BOARD - SEE SPEC SECTION 10 11 00
 - 25 FIRE BLANKET
 - 26 FIRE EXTINGUISHER
 - 27 NEW EXTERIOR WINDOW SYSTEM
 - 28 FIRE EXTINGUISHER
 - 27 NEW EXTERIOR WINDOW SYSTEM
 - 28 NEW UTILITY CHASE TYPE "A" - SEE DETAIL 6/AB.0
 - 29 NEW UTILITY CHASE TYPE "B" - SEE DETAIL 7/AB.0

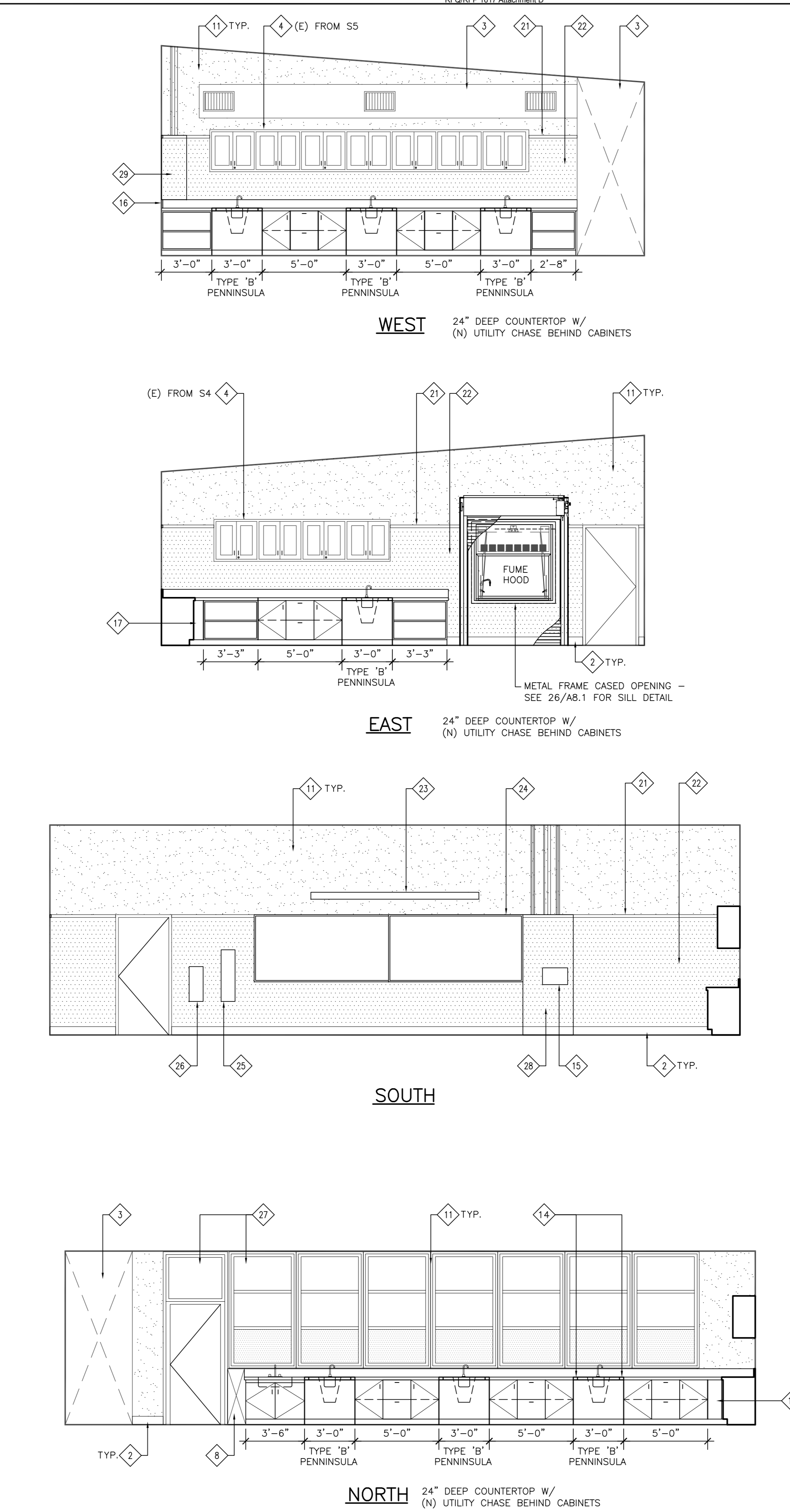

2 INTERIOR ELEVATION - BIOLOGY S5
SCALE: N.T.S.

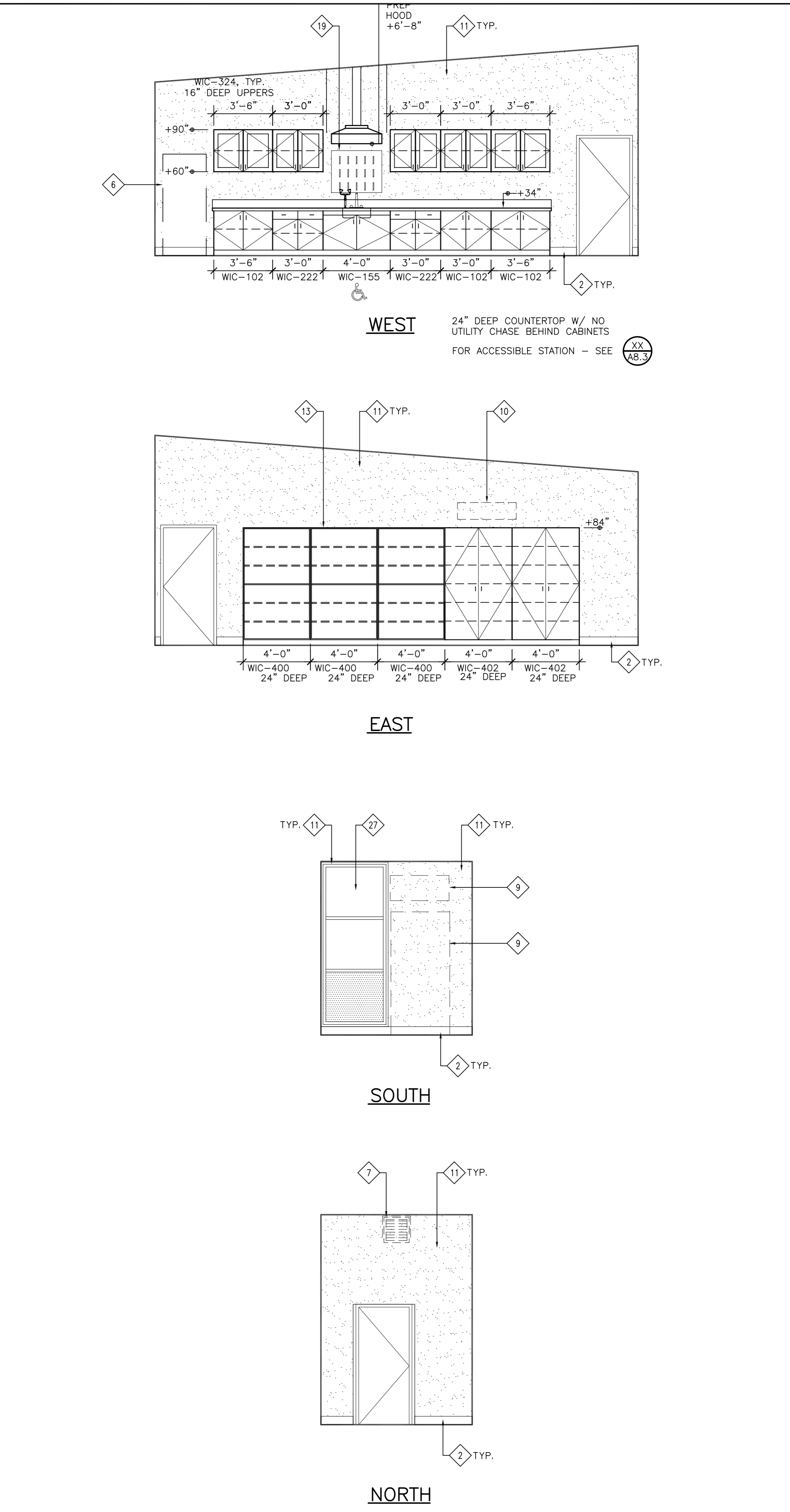

1 INTERIOR ELEVATION - CHEM/BIO PREP S4A
SCALE: N.T.S.

- GENERAL NOTES**
1. CASEWORK MANUFACTURER SHALL NOTE ATTACHMENT DETAIL AND MAKE ACCOMMODATIONS FOR WALL LEDGERS AND SUB-TOP IN CASEWORK FABRICATION.
 2. AT ALL FREE-STANDING VERTICAL CASEWORK LEGS, PROVIDE (1) ANGLE CLIP SIMILAR TO DETAIL 3/AB.0 AT FRONT AND REAR OF LEG WITH 1/4" X 2" EXPANSION BOLT INTO CONCRETE FLOORING.
 3. AT ALL LOCATIONS WHERE NEW CABINET COUNTERTOPS DO NOT ALIGN WITH EXISTING COUNTERTOPS, PROVIDE VERTICAL TRANSITION COUNTERTOP PIECE.
 4. SEE FLOOR PLANS AND FINISH SCHEDULE FOR ITEMS NOT NOTED ON ELEVATIONS.
 5. SEE DETAIL 26 FOR EQUIPMENT MOUNTING HEIGHTS. SEE FLOOR 26/AB.0 FOR LOCATIONS.
 6. SEE SHEET AB.0 FOR CASEWORK DETAILS.
 7. PAINT ALL EXPOSED INTERIOR WALL AND WINDOW TRIM SURFACES THROUGHOUT ALL LABS AND WORKROOMS. PATCH AND REPAIR SURFACES PRIOR TO PAINT.
 8. ALL FINISH KEYNOTES INDICATED HERE SHALL BE CONSIDERED TYPICAL THROUGHOUT FOR SIMILAR CONDITIONS IF SHOWN OR NOT OTHERWISE NOTED. SEE FINISH SCHEDULE FOR ADDITIONAL FINISH INFORMATION THAT MAY NOT BE SHOWN HERE.
 9. WHERE NEW VINYL WRAPPED TACK PANELS OCCUR, ALL NEW EQUIPMENT ITEMS SHALL BE SURFACE MOUNTED OVER NEW PANELS.
 10. AT ALL EXISTING UPPER CABINETS SHOWN TO BE REINSTALLED: CLEAN ALL SURFACES WITH MILD SOLUTION OF TSP. SAND/SCUFF ALL SURFACES OF EXTERIOR BODY OF CABINETS AND PROVIDE A CLEAR SATIN SEALER. INTERIOR OF CABINET SHALL REMAIN AS IS.
 11. AT ALL EXISTING UPPER CABINETS SHOWN TO BE REINSTALLED: REPLACE ALL EXTERIOR PULLS WITH SAME TYPE BEING USED ON NEW CASEWORK.
 12. AT ALL EXISTING UPPER CABINETS SHOWN TO BE REINSTALLED: REPLACE ALL CYLINDER LOCKS WITH NEW TO MATCH NEW CASEWORK LOCKS.
 13. ALL NEW CASEWORK DRAWERS AND DOORS SHALL HAVE PULLS & LOCKS PER SPECIFICATION SECTION 06 41 16.

Mt. Diablo High School
Building S - Science Lab Modernization
 2460 Grant Street
 Concord, California 94520
Mt. Diablo Unified School District

MDUSD

 DIVISION OF THE STATE ARCHITECT
 revision date: _____ by: _____

FILE NO. XX-XX
 IDENTIFICATION STAMP
 DIV. OF THE STATE ARCHITECT
 OFFICE OF REGULATION SERVICES
 APPLICATION NO. 01-
 AC. FLS. SS
 DATE _____

CONSULTANT
nacht&lewis
 600 Q Street, Suite 100
 Sacramento, CA 95811
 www.nachtlewis.com
 916.329.4000

ARCHITECT
REVISIONS

NO.	DESCRIPTION	DATE	REV'D

DATE February 19, 2012
 JOB NO. Y1211.00
SHEET TITLE
Interior Elevations/ Casework Details
 SHEET NO. **A9.3**
 SHEET ___ OF ___ TOTAL
DSA SUBMITTAL SET

ONE AND ONE-HALF INCH = ONE FOOT
 ONE INCH = ONE FOOT
 THREE-QUARTERS INCH = ONE FOOT
 ONE-HALF INCH = ONE FOOT
 ONE-QUARTER INCH = ONE FOOT
 ONE-EIGHTH INCH = ONE FOOT
 ONE-SIXTEENTH INCH = ONE FOOT
 ONE INCH = TWENTY FEET

REQ: REP 1617 Attachment D

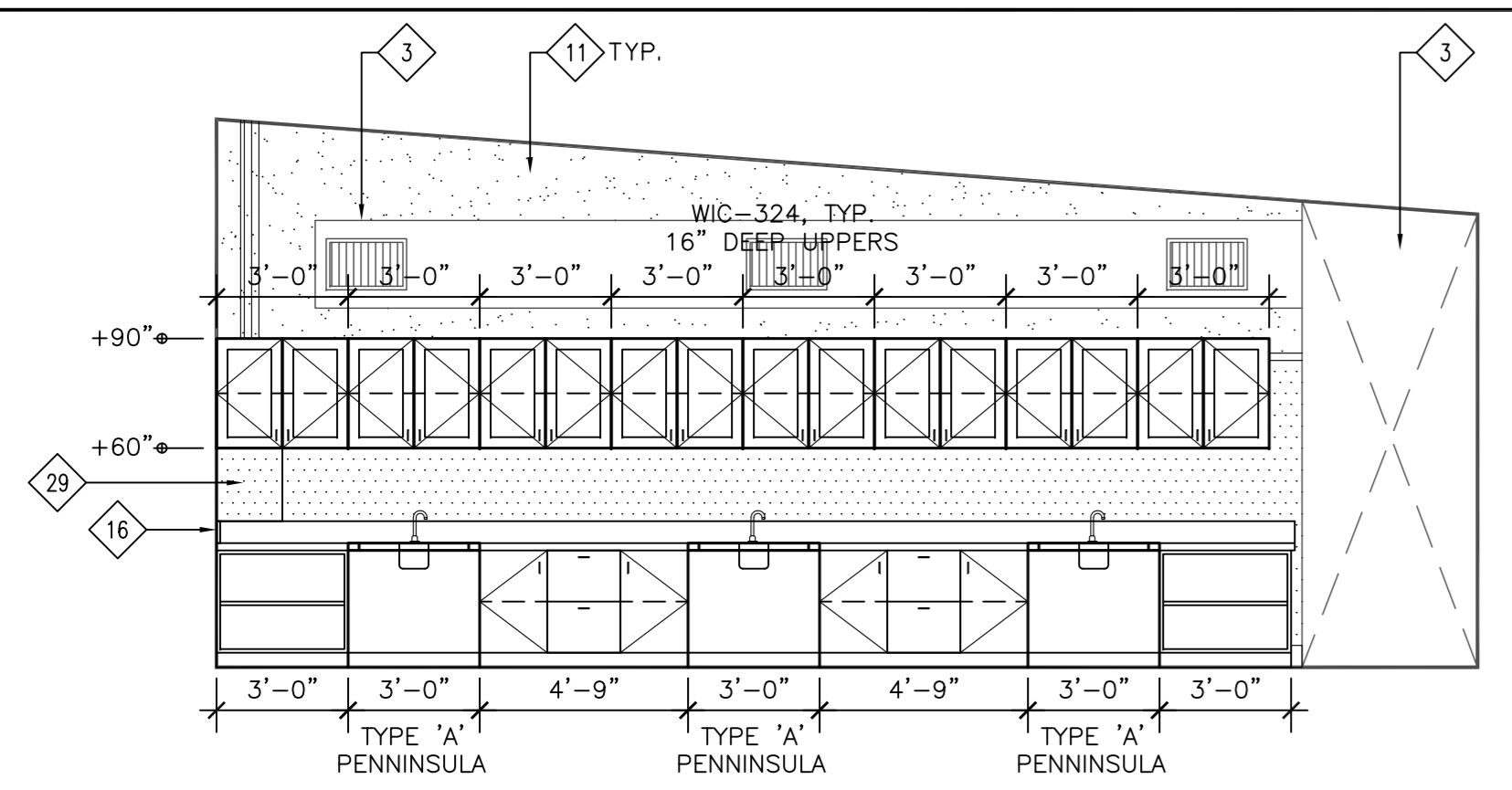

WEST 24" DEEP COUNTERTOP W/
(N) UTILITY CHASE BEHIND CABINETS

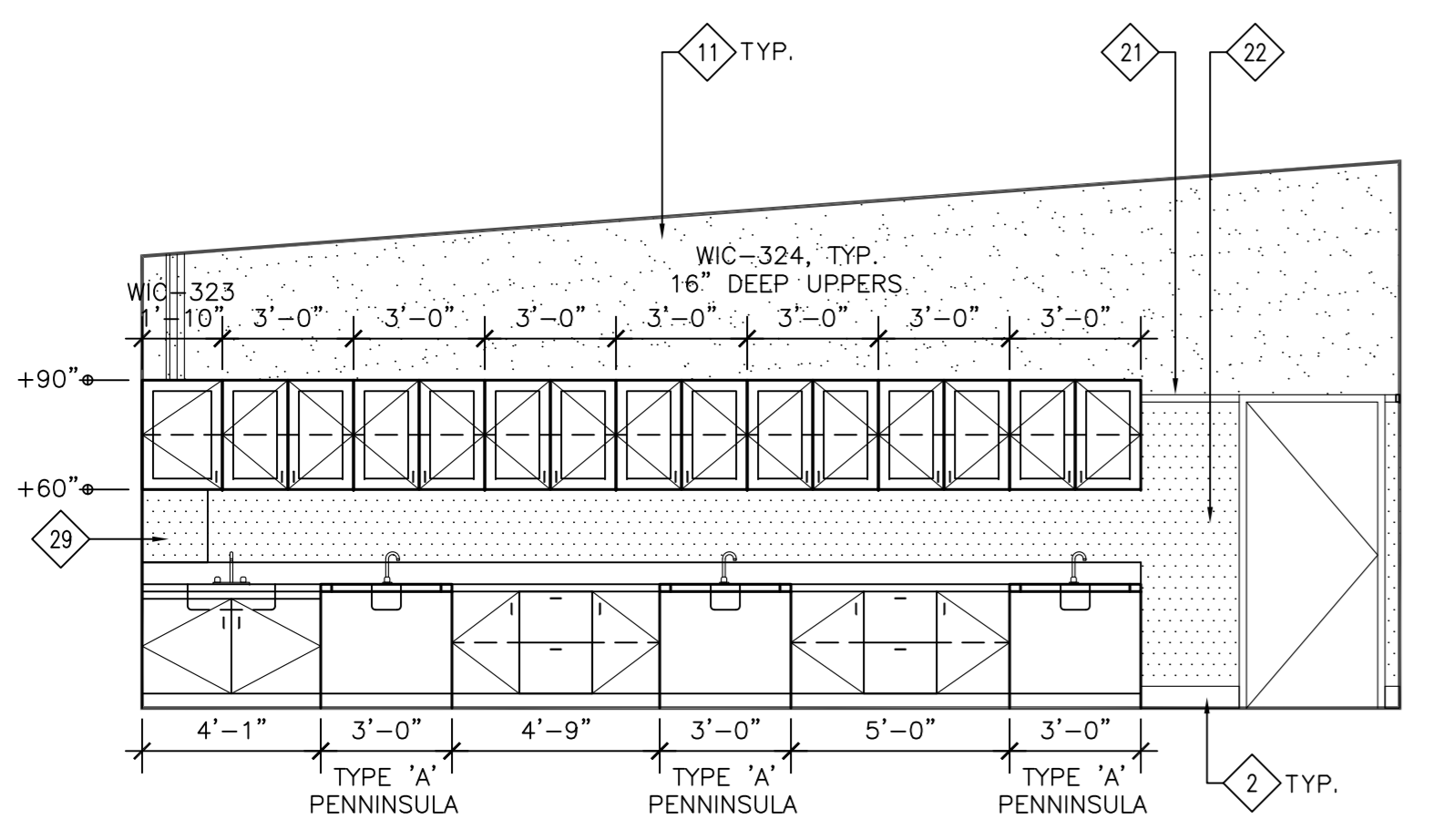

EAST 24" DEEP COUNTERTOP W/
(N) UTILITY CHASE BEHIND CABINETS

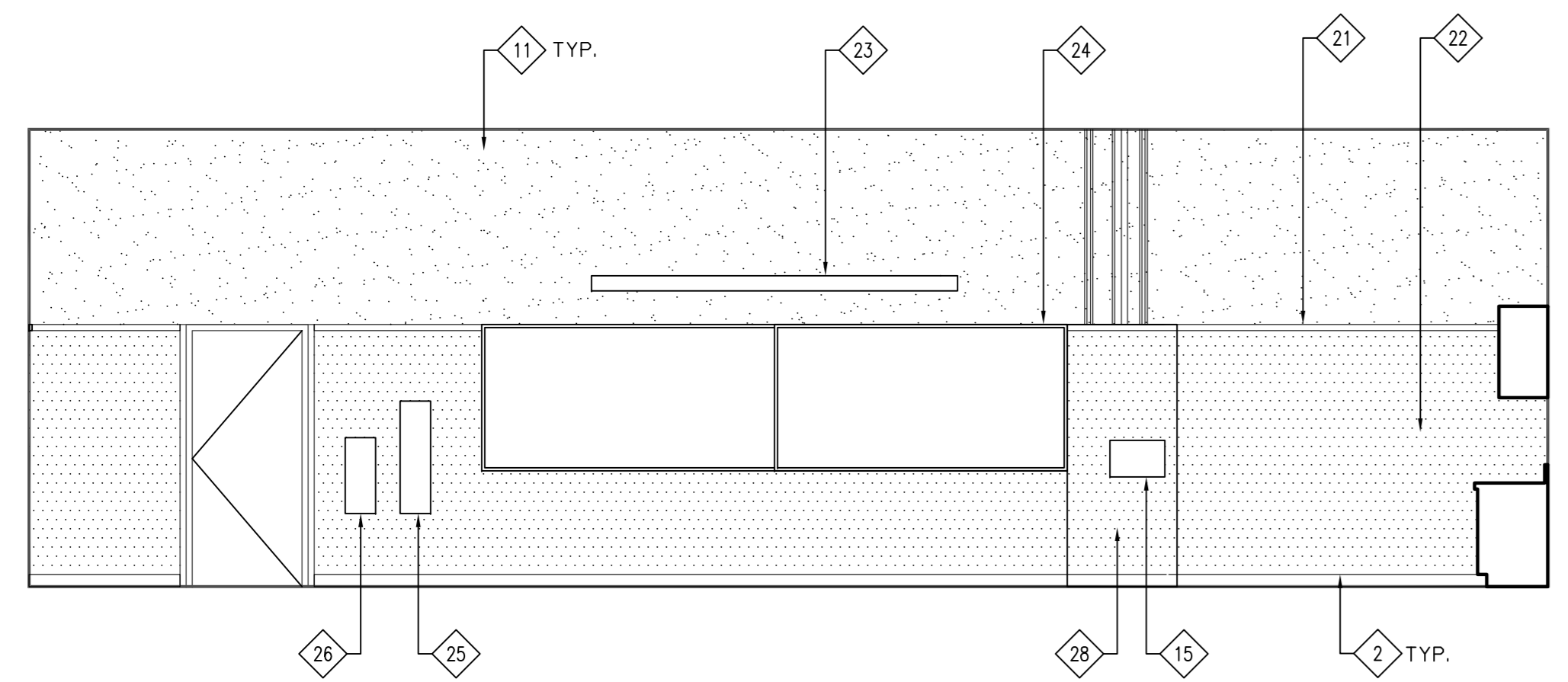

SOUTH

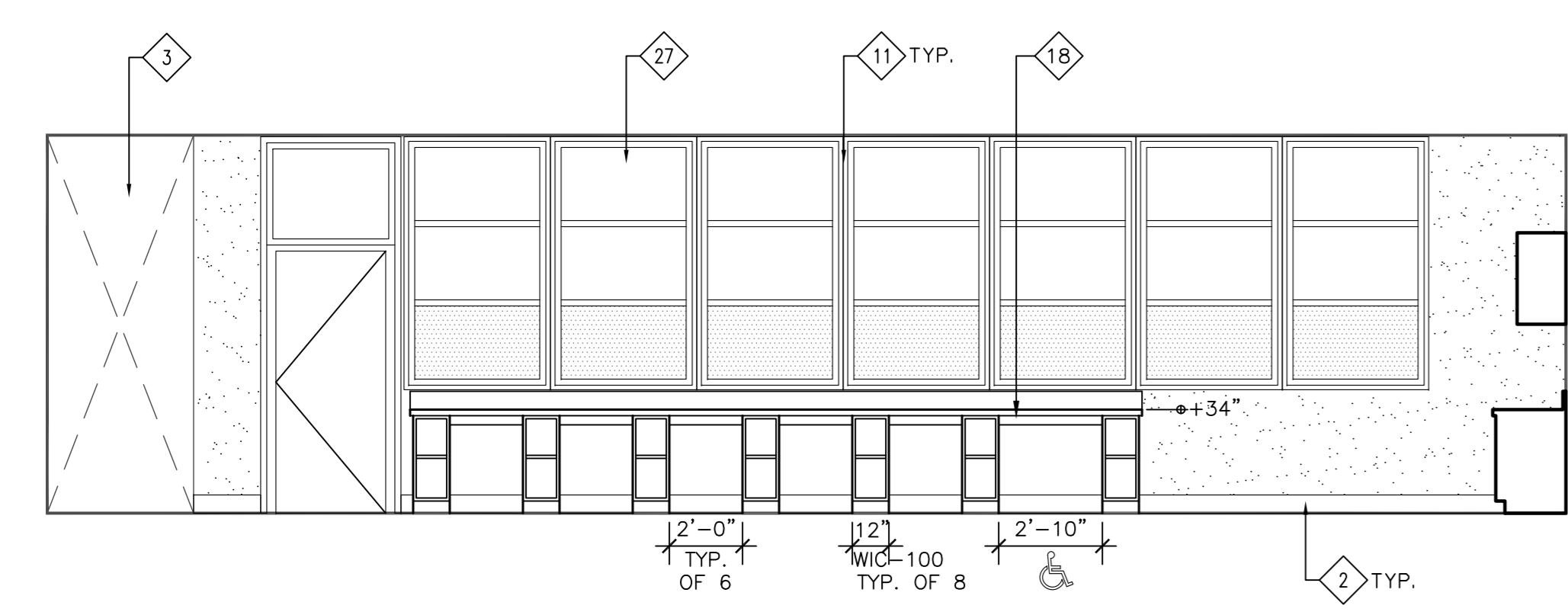

NORTH 24" DEEP COUNTERTOP W/ NO
UTILITY CHASE BEHIND CABINETS
FOR ACCESSIBLE STATION - SEE AK
AB.3

3 INTERIOR ELEVATION - PHYSICS S9
SCALE: N.T.S.

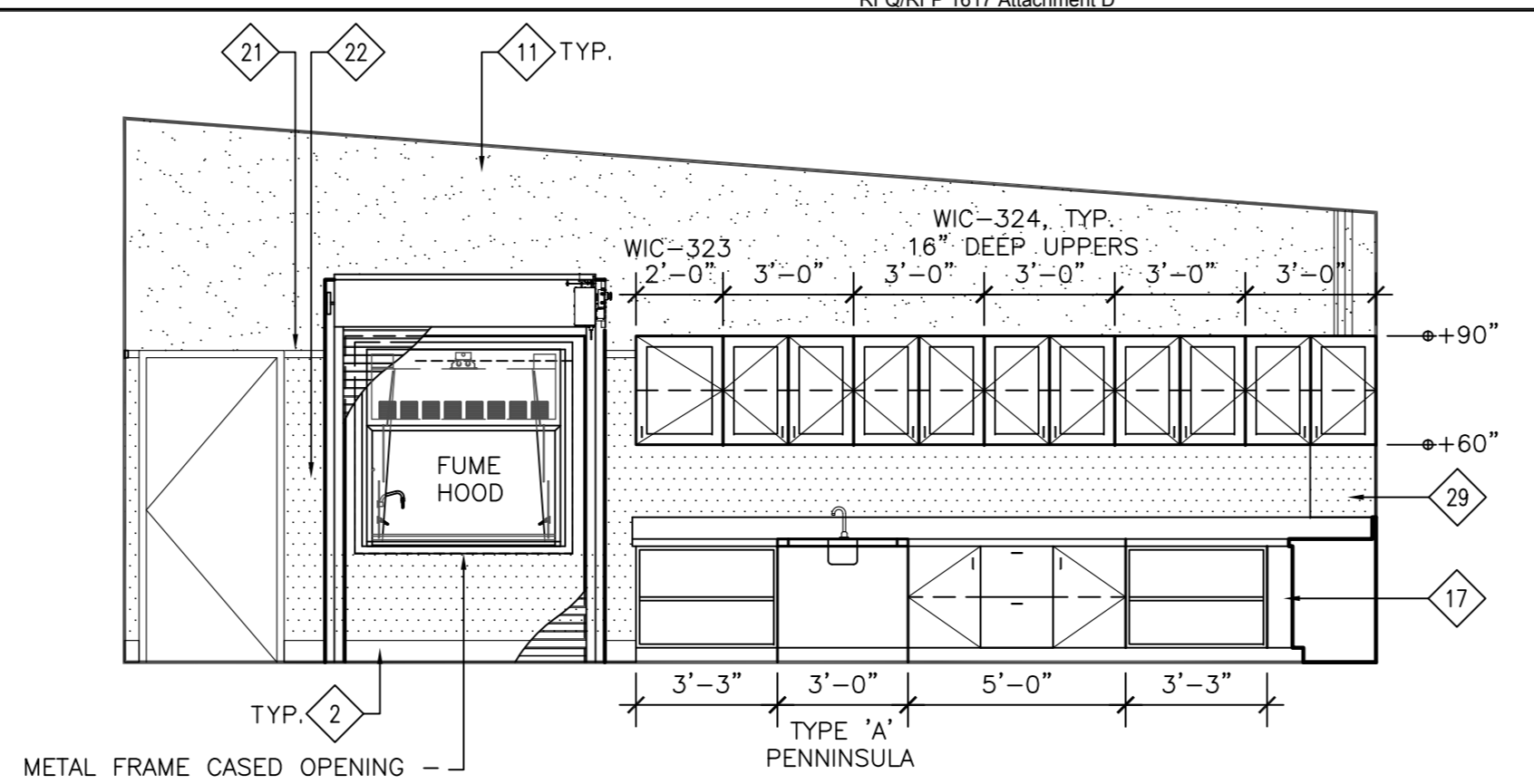

WEST 24" DEEP COUNTERTOP W/
(N) UTILITY CHASE BEHIND CABINETS

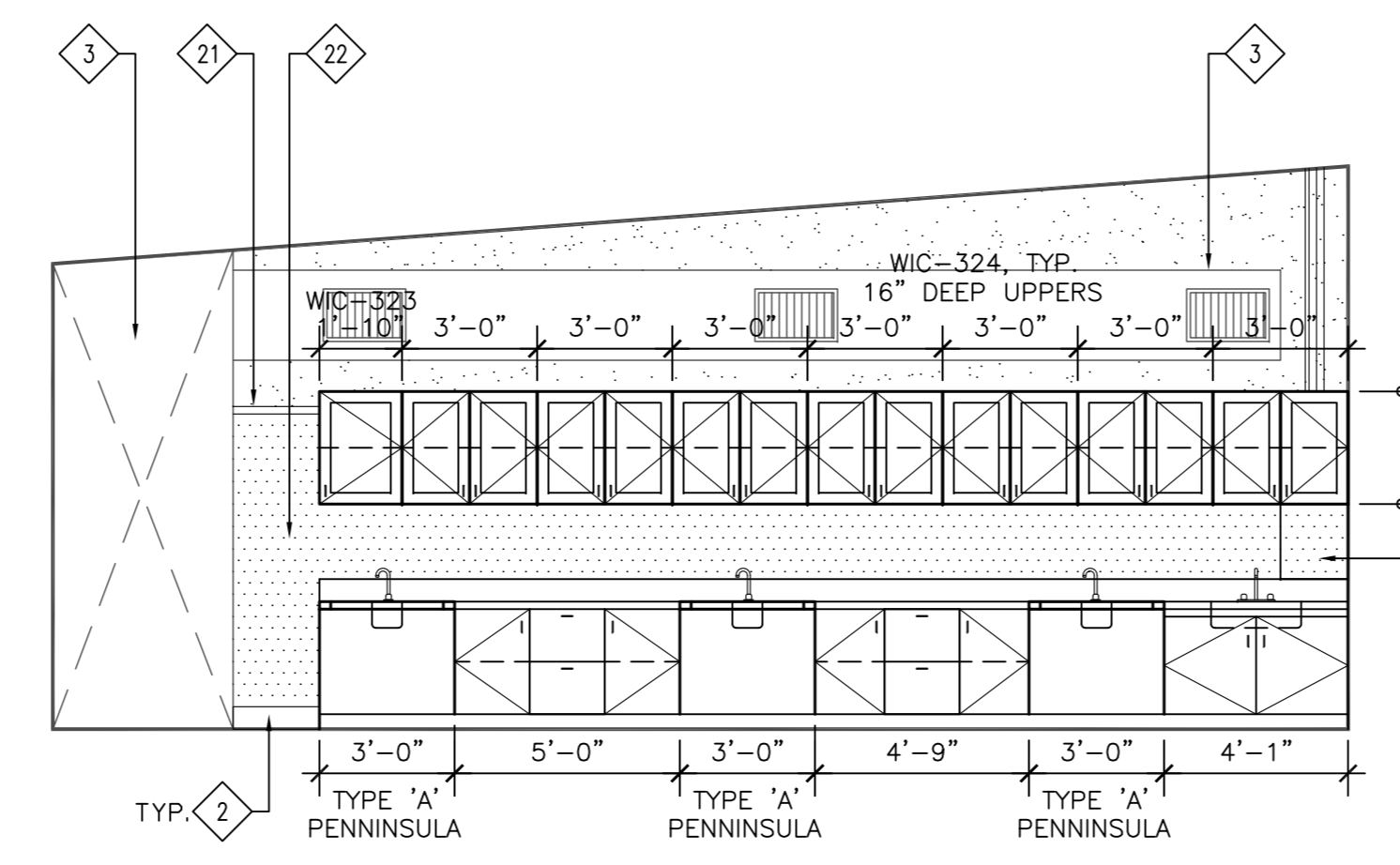

EAST 24" DEEP COUNTERTOP W/
(N) UTILITY CHASE BEHIND CABINETS

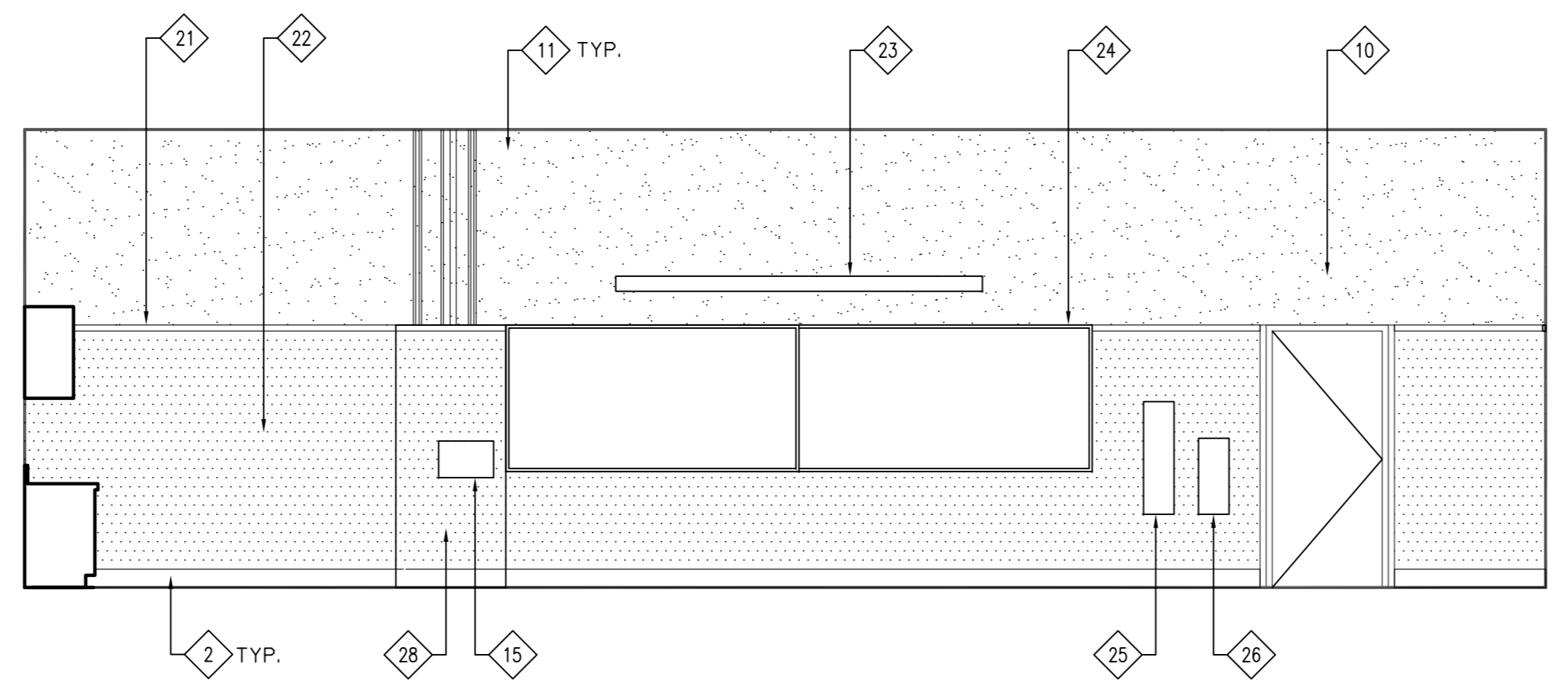

SOUTH

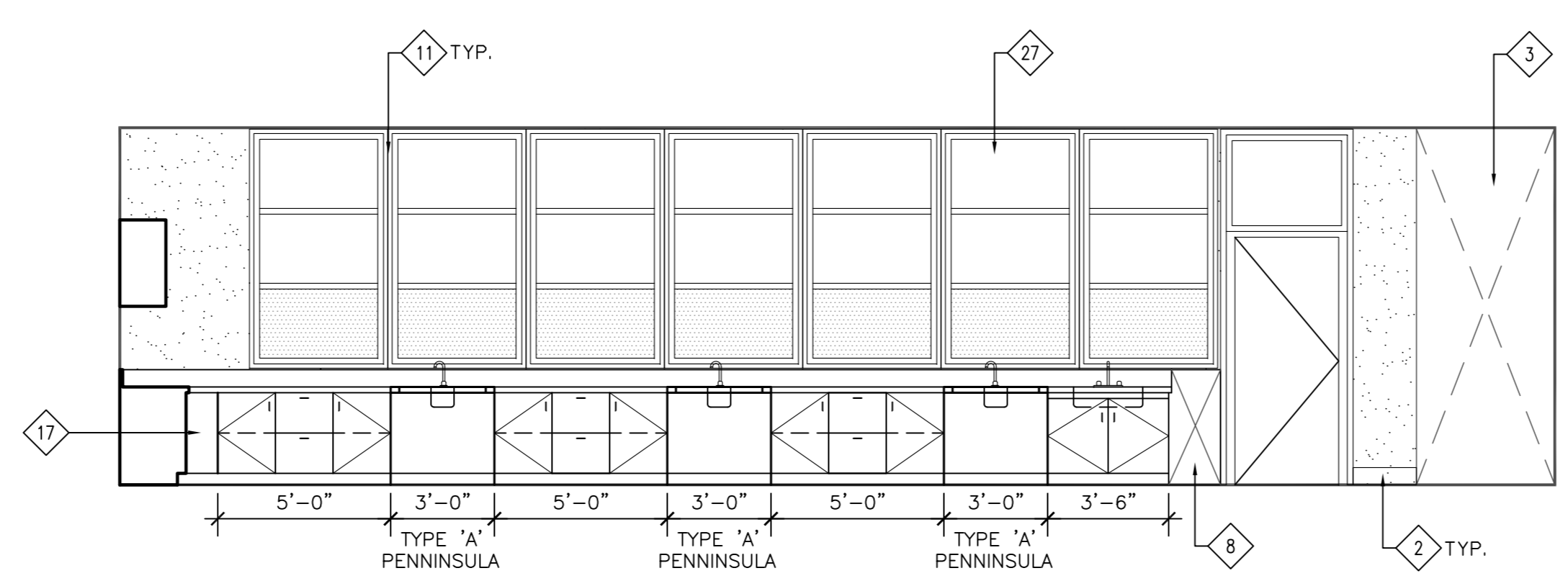

NORTH 24" DEEP COUNTERTOP W/
(N) UTILITY CHASE BEHIND CABINETS

2 INTERIOR ELEVATION - CHEMISTRY S7
SCALE: N.T.S.

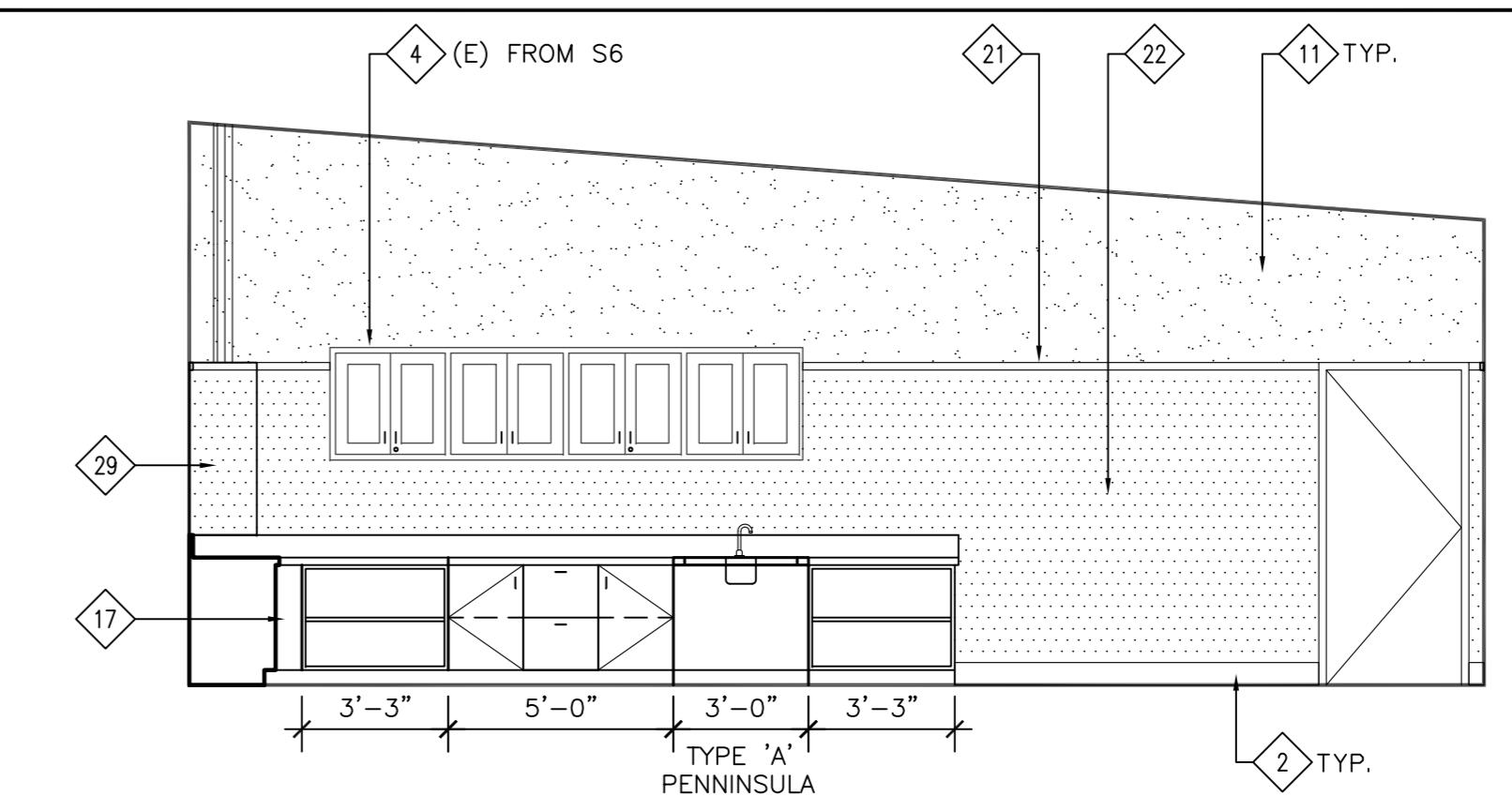

WEST 24" DEEP COUNTERTOP W/
(N) UTILITY CHASE BEHIND CABINETS

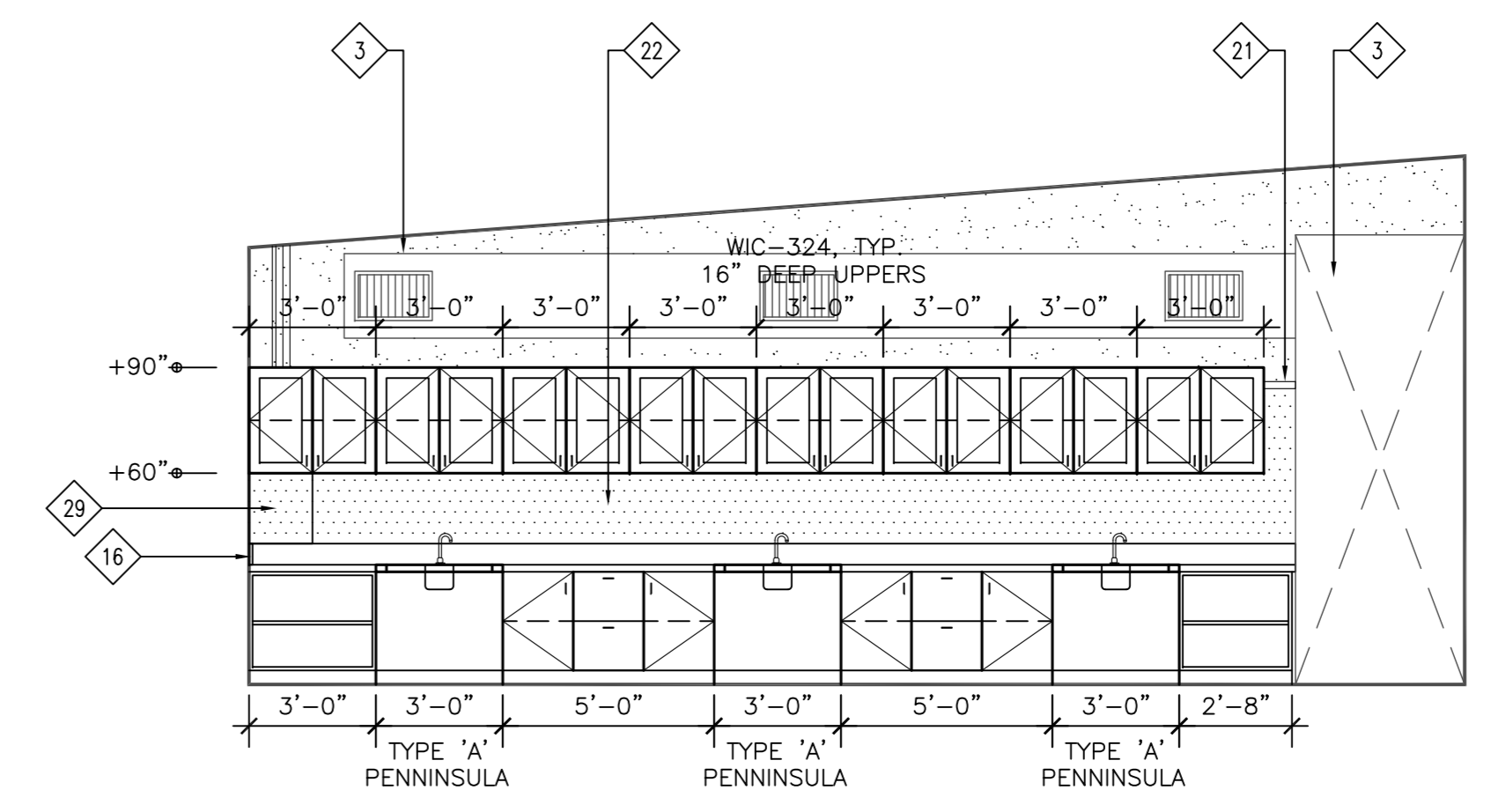

EAST 24" DEEP COUNTERTOP W/
(N) UTILITY CHASE BEHIND CABINETS

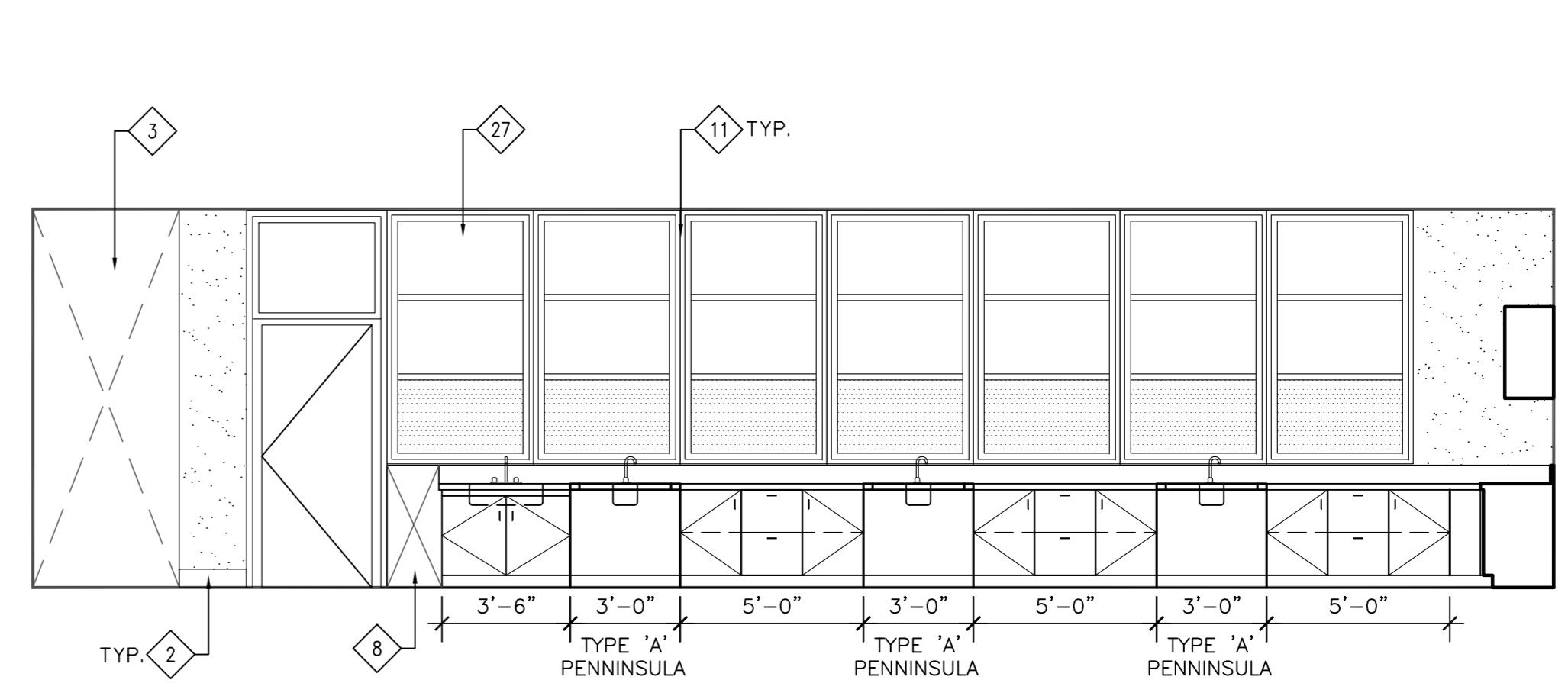

SOUTH 24" DEEP COUNTERTOP W/
(N) UTILITY CHASE BEHIND CABINETS

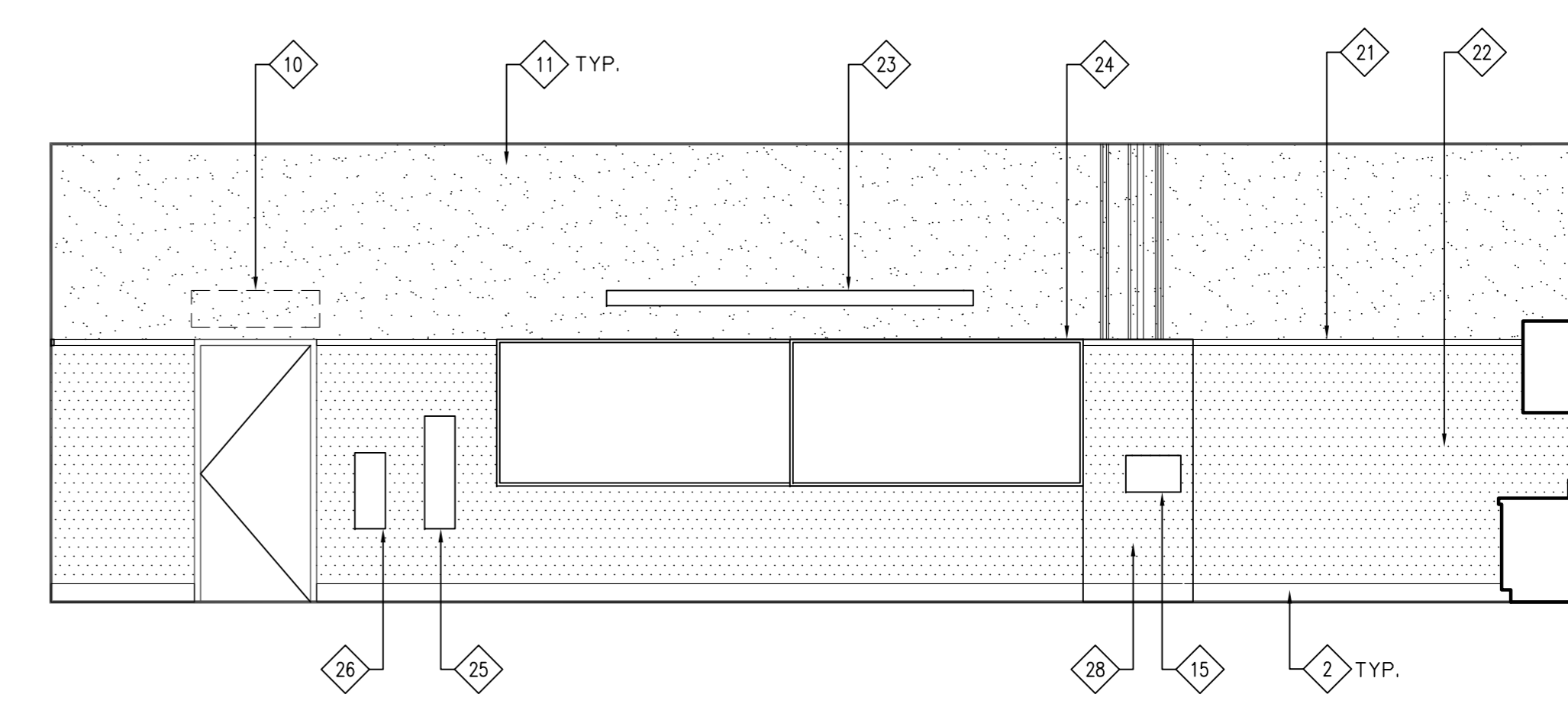

NORTH

1 INTERIOR ELEVATION - CHEMISTRY S6
SCALE: N.T.S.

NEW WORK KEYNOTES:

THESE NEW WORK NOTES APPLY TO THIS SHEET ONLY

- 1 EXISTING RELIEF AIR HOOD TO REMAIN
- 2 RESILIENT BASE
- 3 EXISTING HVAC SYSTEM TO REMAIN, U.O.N.
- 4 REHANG (E) REFINISHED CABINETS AT LOCATIONS NOTED. NOTE INDICATES ORIGINAL ROOM NUMBER OF (E) CABINET TO BE REHUNG.
- 5 NOT USED
- 6 REFRIGERATOR (NIC)
- 7 (E) HEATER TO BE REMOVED - PATCH AND REPAIR REMAINING WALL PENETRATIONS
- 8 REMOVE (E) 1/4" AC PLYWOOD WALL PANEL AT EXPOSED WALL AREA AND REPLACE IN KIND WITH NEW PAINT
- 9 INFILL OPENING(S) IN (E) WALL - TAPE AND TEXTURE TO MATCH (E). PAINT PER FINISH SCHEDULE
- 10 REMOVE (E) TRANSFER GRILL - PATCH AND REPAIR OPENING
- 11 PREP AND PAINT (E) WALL SURFACES AND WOOD WINDOW TRIM (WHERE OCCURS)
- 12 REMOVE (E) TRANSFER GRILL - PATCH AND REPAIR OPENING
- 13 BASE CABINET CONFIGURATION - PROVIDE NEW RESILIENT BASE.
- 14 DOOR/OPENING WALL INFILL
- 15 GAS SHUT-OFF VALVE WITH SURFACE MOUNTED GAS PIPING. SCRIBE VINYL TACK BOARD TIGHT TO PIPE AND VALVE BOX.
- 16 PROVIDE SIDE SPLASH

- 17 FILLER PANEL
- 18 PLASTIC LAMINATE APRON - 27" MIN. CLR. TYP.
- 19 PEG RACK - SEE SPEC SECTION 10 00 00.
- 20 FUME HOOD BASE TOP CONFIGURATION: - PROVIDE DISHED WORK SURFACE WITH LEFT FRONT CLIP SINK, MODEL No. 20L17300 BY THERMO SCIENTIFIC HAMILTON OR EQUAL. - PROVIDE POLYOLEFIN CUPSINK MODEL No. 34113700 BY THERMO SCIENTIFIC HAMILTON OR EQUAL. - PROVIDE NEW RESILIENT BASE.
- 21 NEW PAINTED WOOD TRIM - SEE DETAIL 25
AB.0
- 22 NEW VINYL WRAPPED TACK PANEL
- 23 NEW PROJECTION SCREEN - SEE 29
AB.0 FOR MOUNTING DETAIL, TYP
- 24 NEW MARKER BOARD - SEE SPEC SECTION 10 11 00
- 25 FIRE BLANKET
- 26 FIRE EXTINGUISHER
- 27 NEW EXTERIOR WINDOW SYSTEM
- 28 FIRE EXTINGUISHER
- 27 NEW EXTERIOR WINDOW SYSTEM
- 28 NEW UTILITY CHASE TYPE "A" - SEE DETAIL 6
AB.0
- 29 NEW UTILITY CHASE TYPE "B" - SEE DETAIL 7
AB.0

GENERAL NOTES

1. CASEWORK MANUFACTURER SHALL NOTE ATTACHMENT DETAIL AND MAKE ACCOMMODATIONS FOR WALL LEDGERS AND SUB-TOP IN CASEWORK FABRICATION.
2. AT ALL FREE-STANDING VERTICAL CASEWORK LEGS, PROVIDE (1) ANGLE CLIP SIMILAR TO DETAIL 3/AB.0 AT FRONT AND REAR OF LEG WITH 1/4" X 2" EXPANSION BOLT INTO CONCRETE FLOORING.
3. AT ALL LOCATIONS WHERE NEW CABINET COUNTERTOPS DO NOT ALIGN WITH EXISTING COUNTERTOPS, PROVIDE VERTICAL TRANSITION COUNTERTOP PIECE.
4. SEE FLOOR PLANS AND FINISH SCHEDULE FOR ITEMS NOT NOTED ON ELEVATIONS.
5. SEE DETAIL 26
AB.3 FOR EQUIPMENT MOUNTING HEIGHTS. SEE FLOOR PLANS FOR LOCATIONS.
6. SEE SHEET AB.0 FOR CASEWORK DETAILS.
7. PAINT ALL EXPOSED INTERIOR WALL AND WINDOW TRIM SURFACES THROUGHOUT ALL LABS AND WORKROOMS. PATCH AND REPAIR SURFACES PRIOR TO PAINT.
8. ALL FINISH KEYNOTES INDICATED HERE SHALL BE CONSIDERED TYPICAL THROUGHOUT FOR SIMILAR CONDITIONS IF SHOWN OR NOT OTHERWISE NOTED. SEE FINISH SCHEDULE FOR ADDITIONAL FINISH INFORMATION THAT MAY NOT BE SHOWN HERE.
9. WHERE NEW VINYL WRAPPED TACK PANELS OCCUR, ALL NEW EQUIPMENT ITEMS SHALL BE SURFACE MOUNTED OVER NEW PANELS.
10. AT ALL EXISTING UPPER CABINETS SHOWN TO BE REINSTALLED: CLEAN ALL SURFACES WITH MILD SOLUTION OF TSP. SAND/SCUFF ALL SURFACES OF EXTERIOR BODY OF CABINETS AND PROVIDE A CLEAR SATIN SEALER. INTERIOR OF CABINET SHALL REMAIN AS IS.
11. AT ALL EXISTING UPPER CABINETS SHOWN TO BE REINSTALLED: REPLACE ALL EXTERIOR PULLS WITH SAME TYPE BEING USED ON NEW CASEWORK.
12. AT ALL EXISTING UPPER CABINETS SHOWN TO BE REINSTALLED: REPLACE ALL CYLINDER LOCKS WITH NEW TO MATCH NEW CASEWORK LOCKS.
13. ALL NEW CASEWORK DRAWERS AND DOORS SHALL HAVE PULLS & LOCKS PER SPECIFICATION SECTION 06 41 16.

Mt. Diablo High School
Building S - Science Lab Modernization
 2460 Grant Street
 Concord, California 94520
Mt. Diablo Unified School District



FILE NO. XX-XX
 IDENTIFICATION STAMP
 DIV. OF THE STATE ARCHITECT
 OFFICE OF REGULATION SERVICES
 APPLICATION NO. 01-
 AC. FLS. SS
 DATE

DIVISION OF THE STATE ARCHITECT
 revision date: by:

CONSULTANT
nacht&lewis
 600 Q Street, Suite 100
 Sacramento, CA 95811
 www.nachtlewis.com
 916.329.4000

ARCHITECT
REVISIONS

NO.	DESCRIPTION	DATE	REV'D

DATE February 19, 2012
 JOB NO. Y1211.00
 SHEET TITLE
**Interior Elevations/
 Casework
 Details**
 SHEET NO.
A9.4
 SHEET ___ OF ___ TOTAL
 DSA SUBMITTAL SET

ONE AND ONE-HALF INCH = ONE FOOT
 ONE INCH = ONE FOOT
 THREE-QUARTERS INCH = ONE FOOT
 ONE-HALF INCH = ONE FOOT
 ONE-QUARTER INCH = ONE FOOT
 ONE-EIGHTH INCH = ONE FOOT
 ONE-SIXTEENTH INCH = ONE FOOT
 ONE INCH = TWENTY FEET

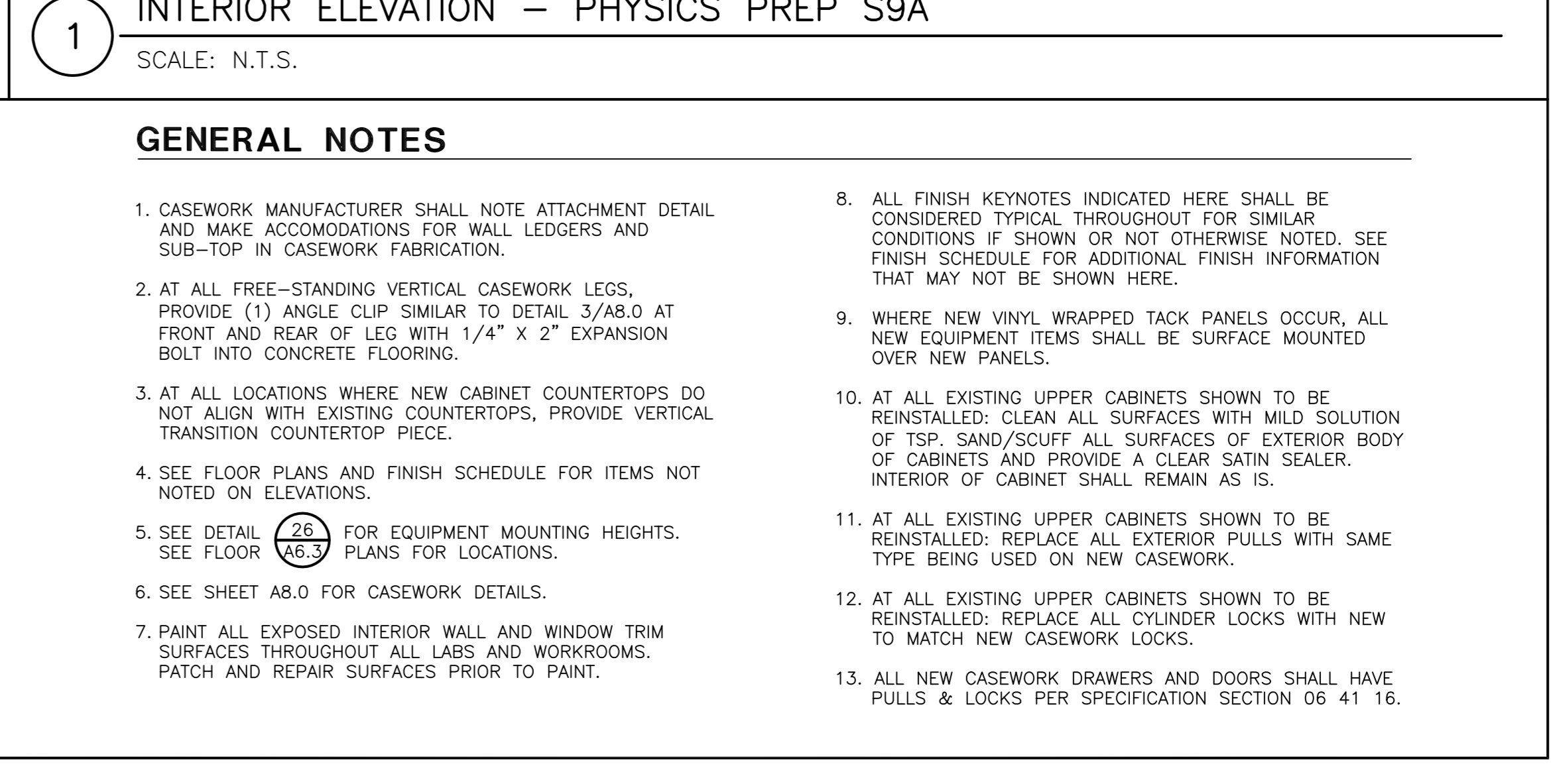
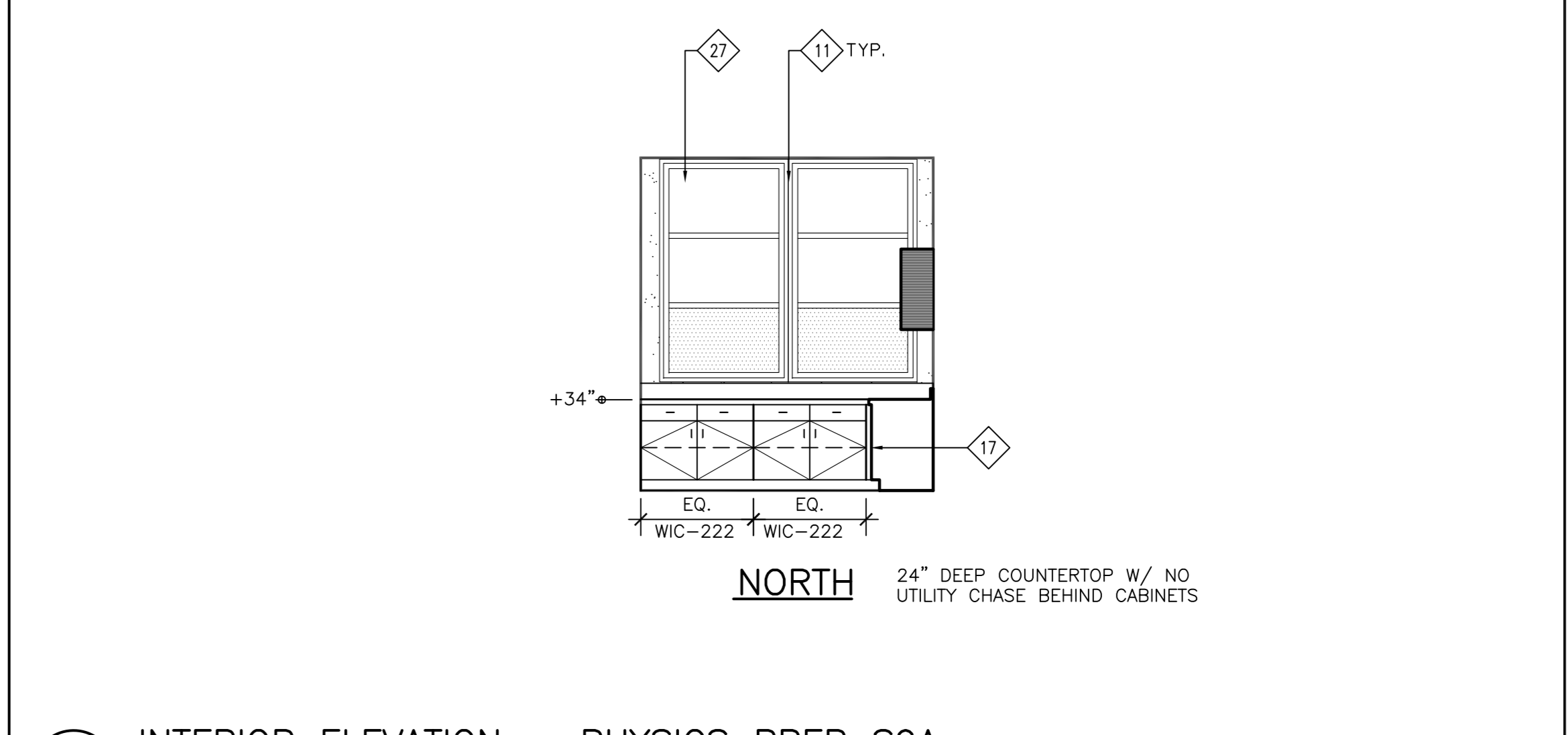
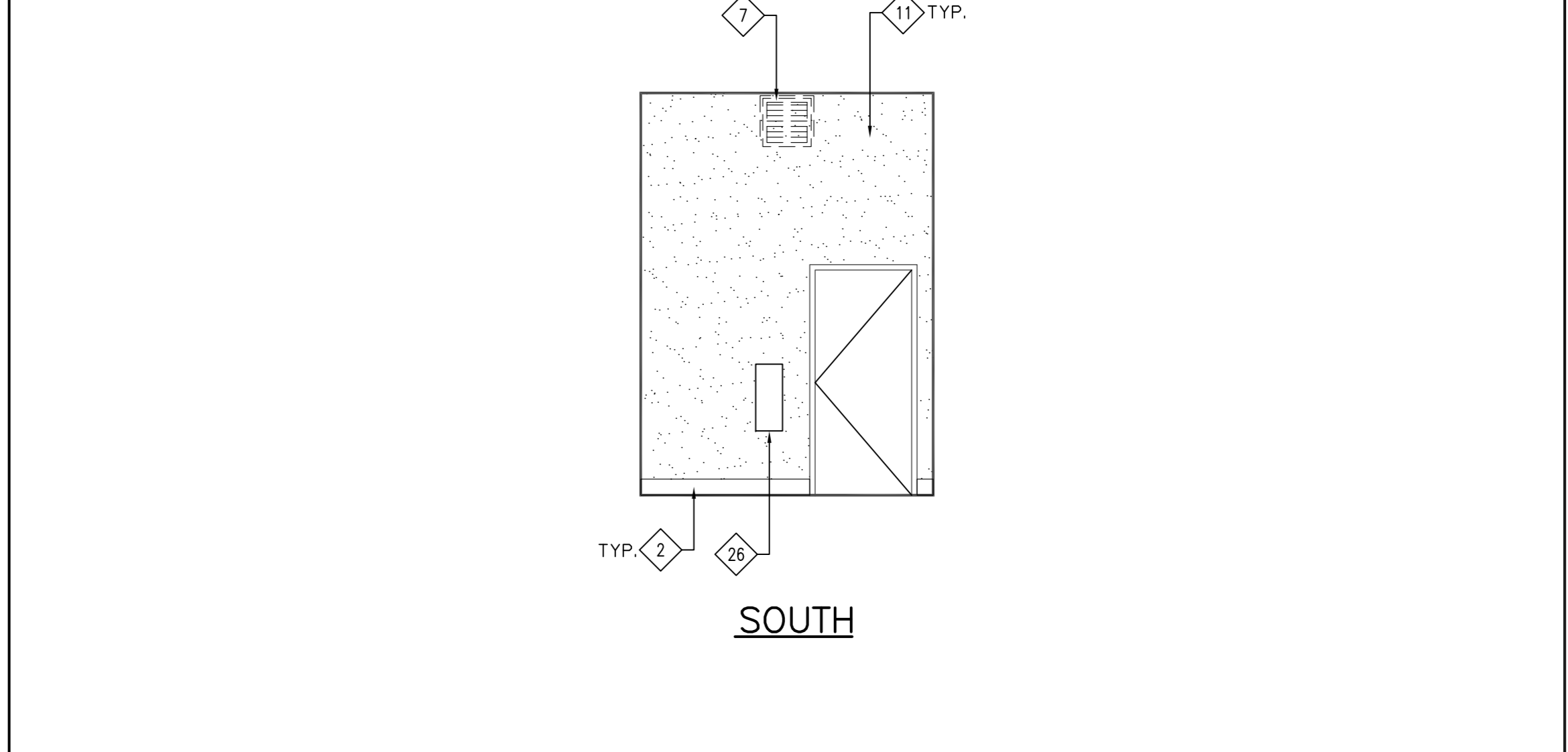
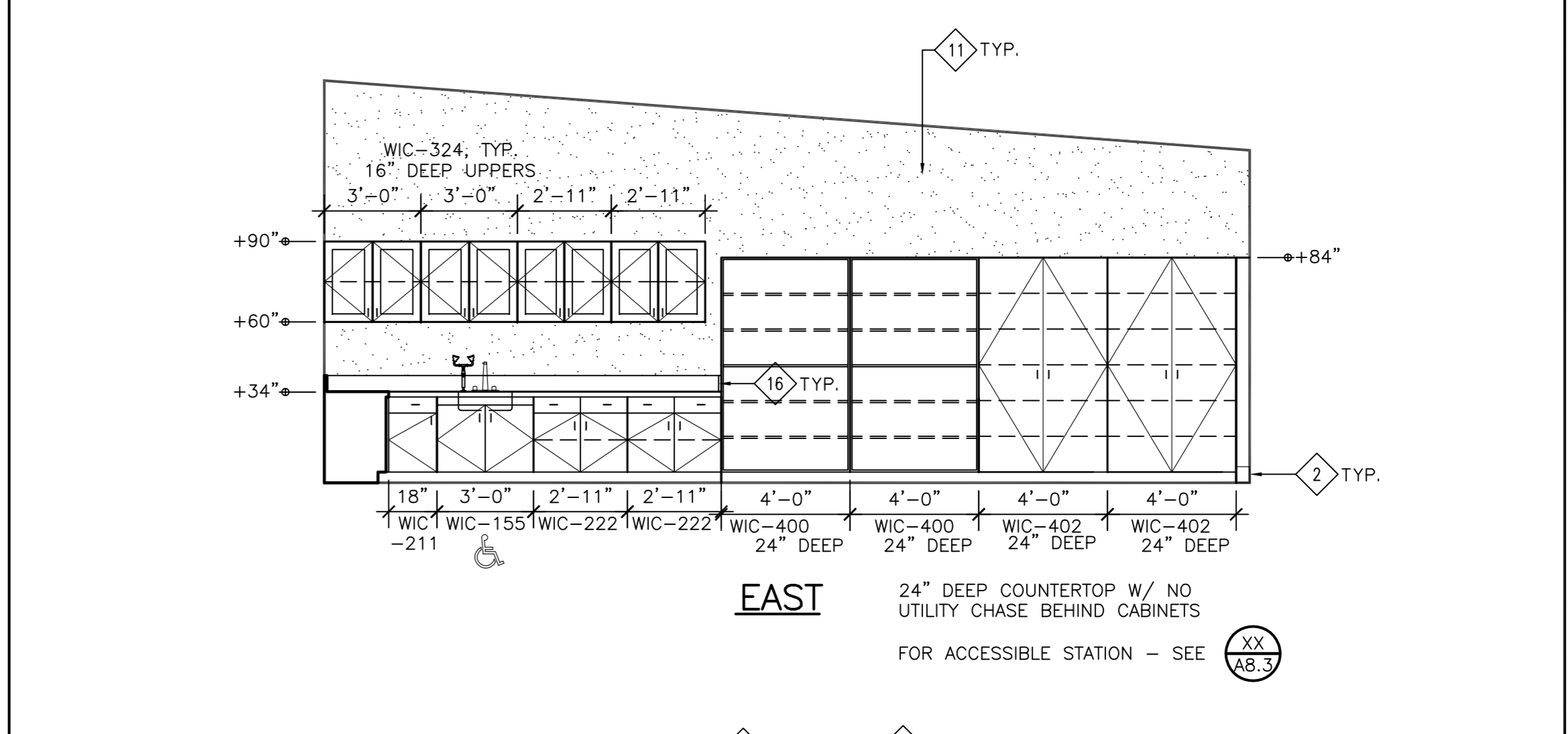
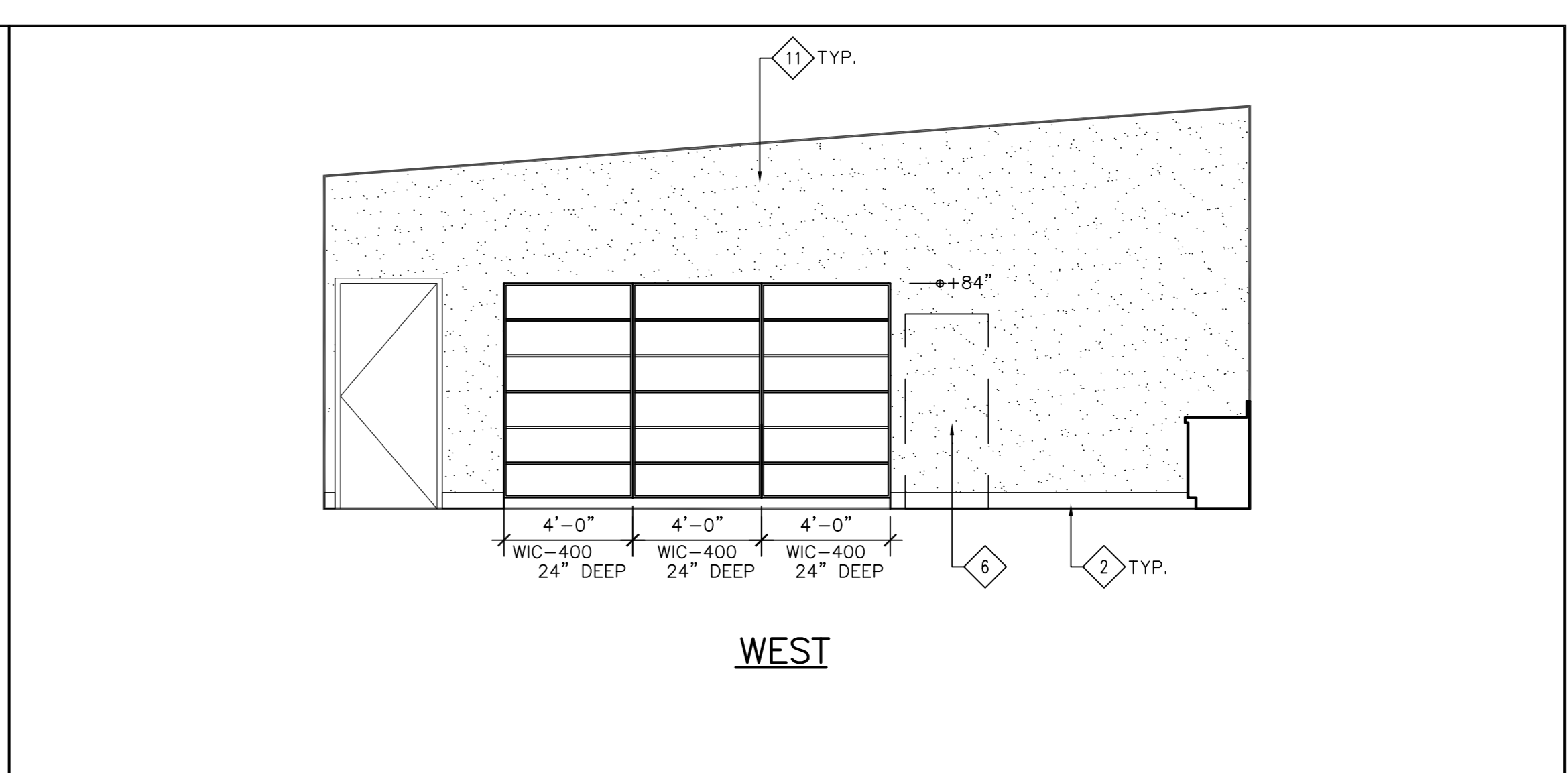
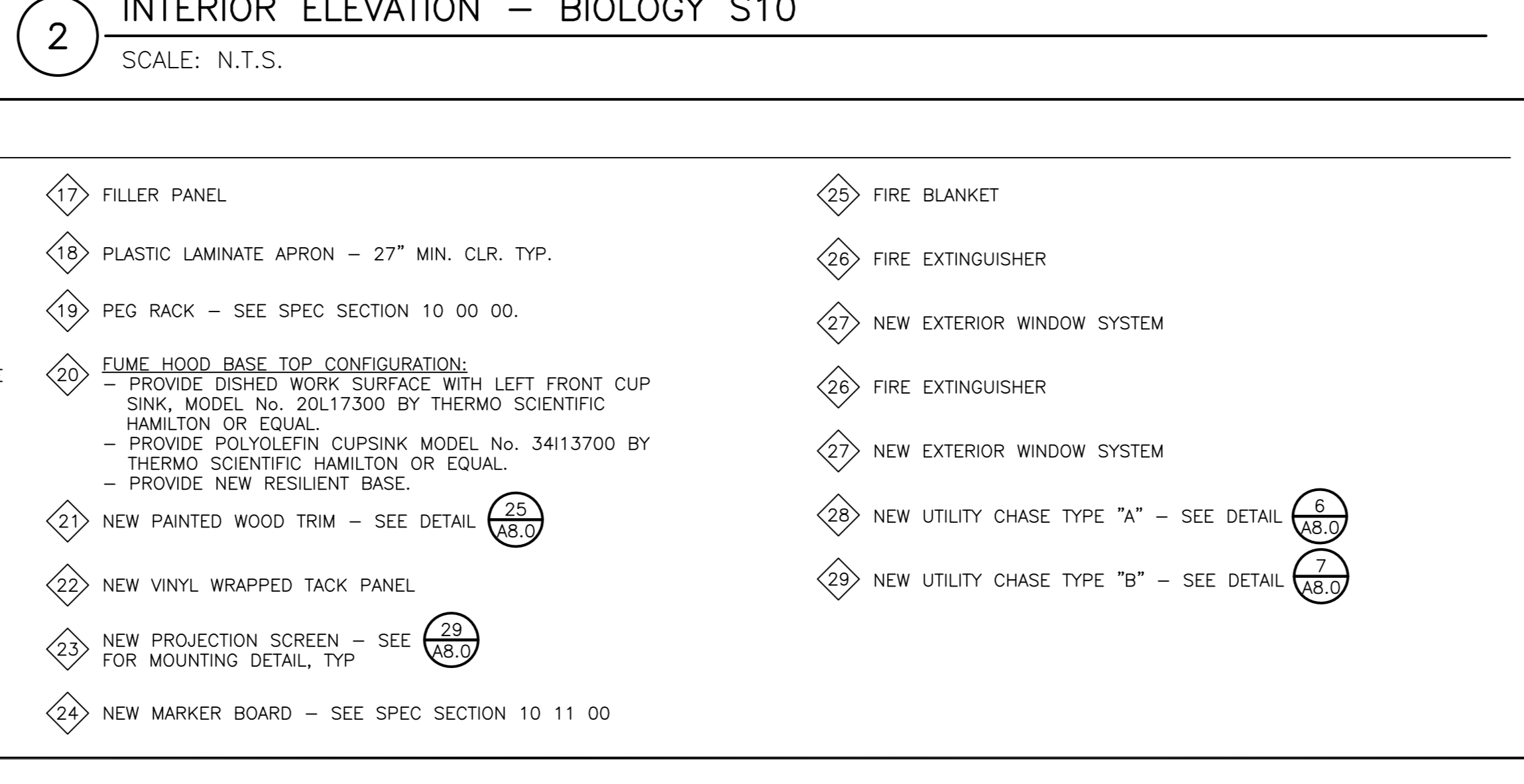
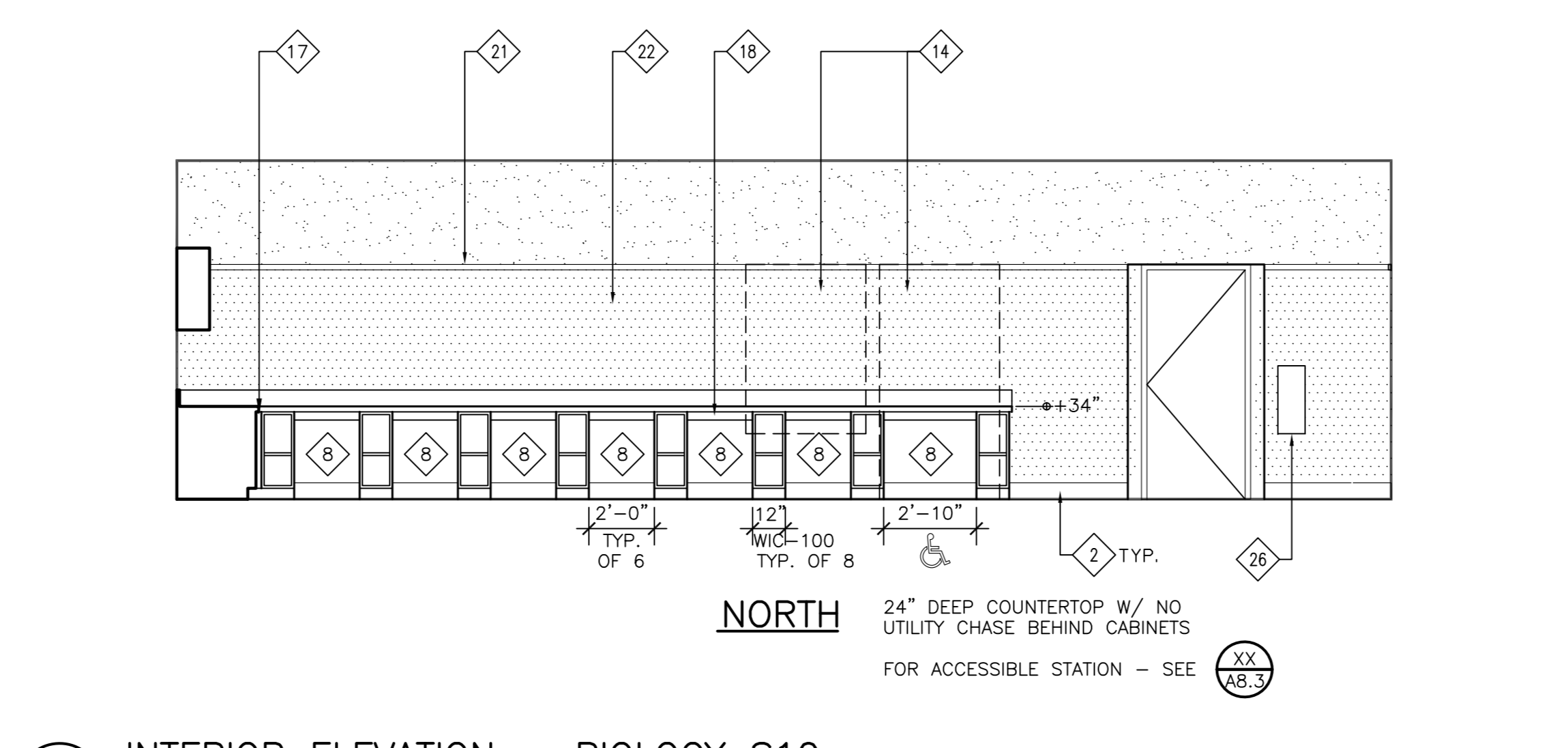
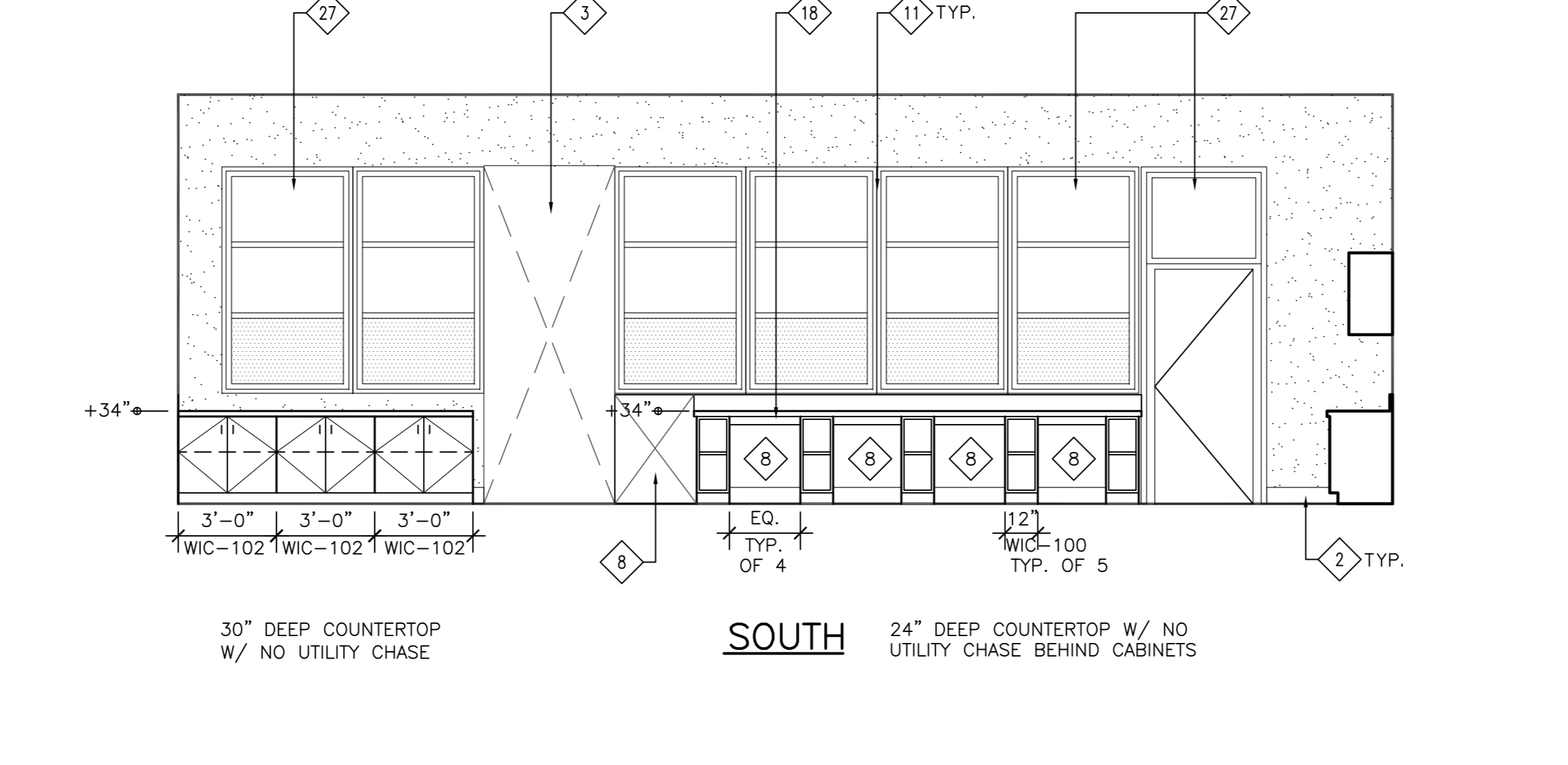
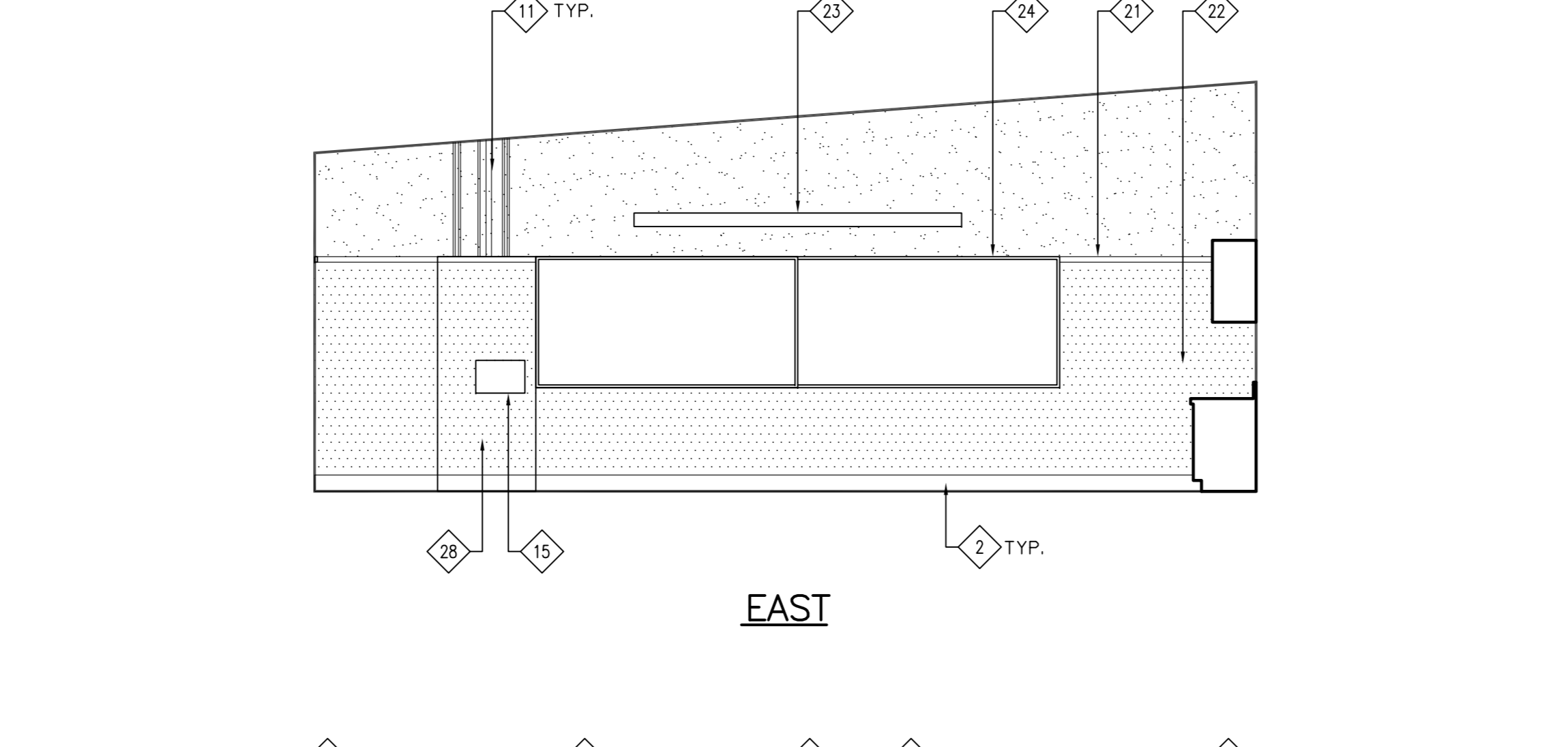
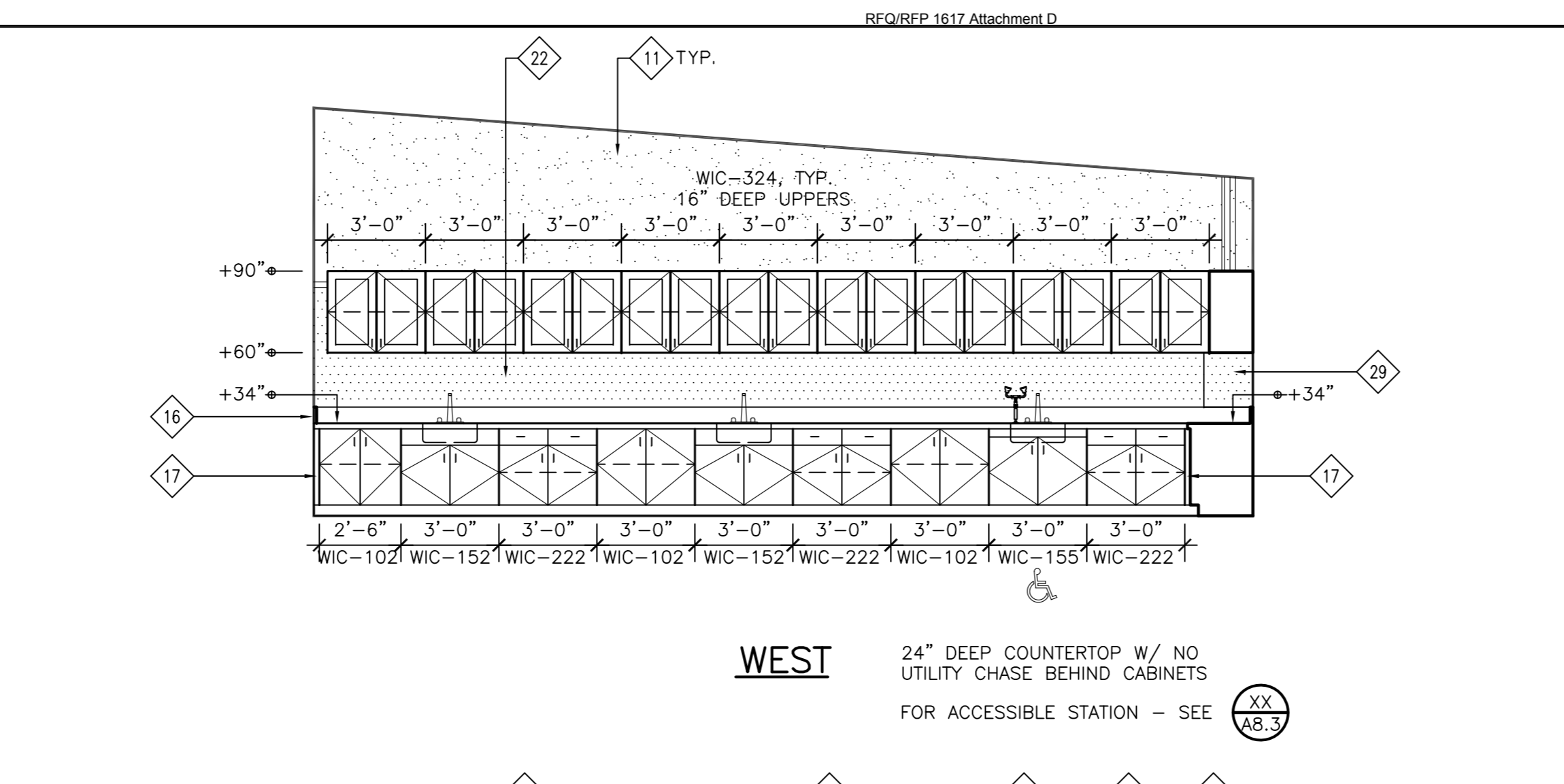
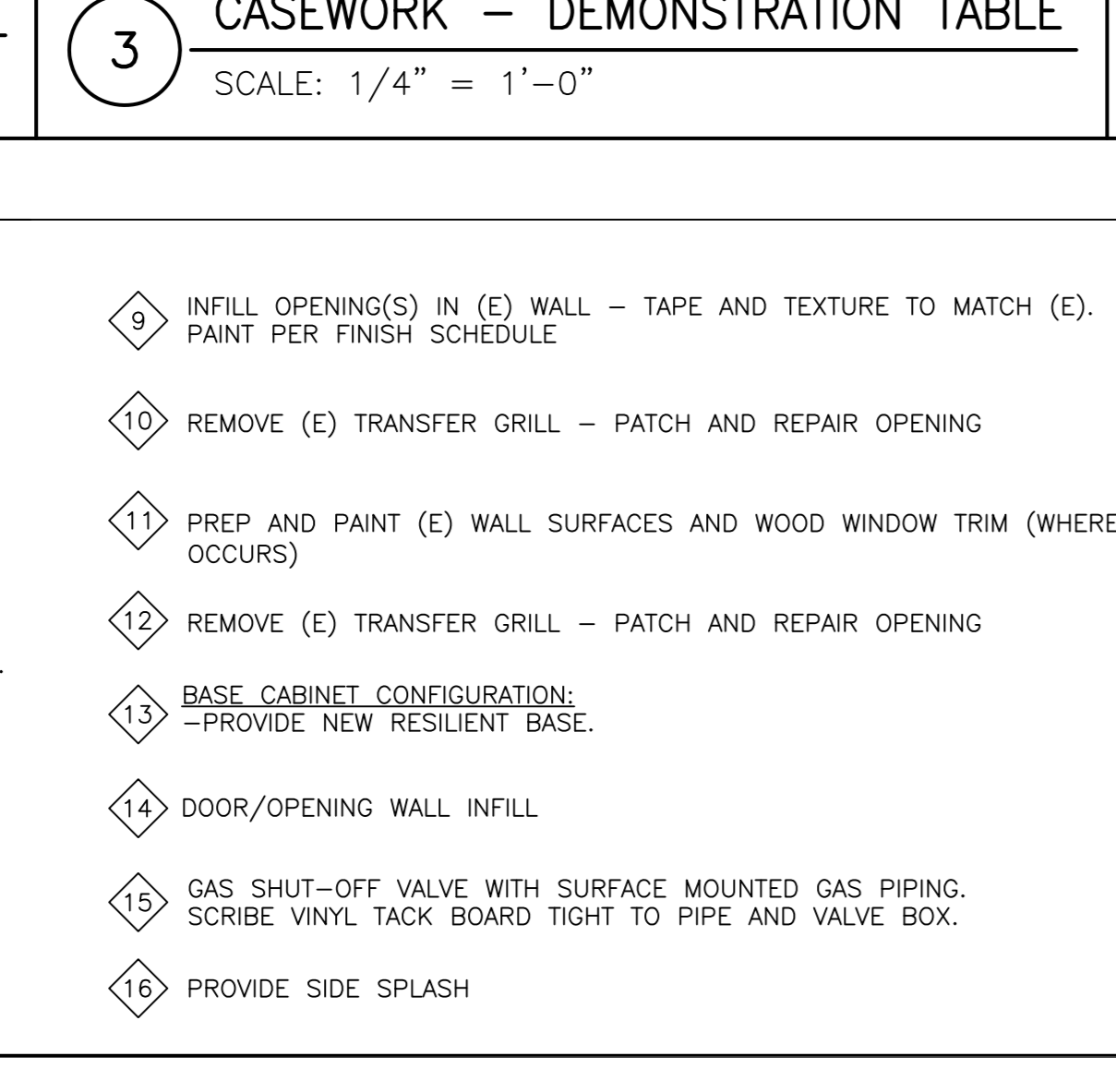
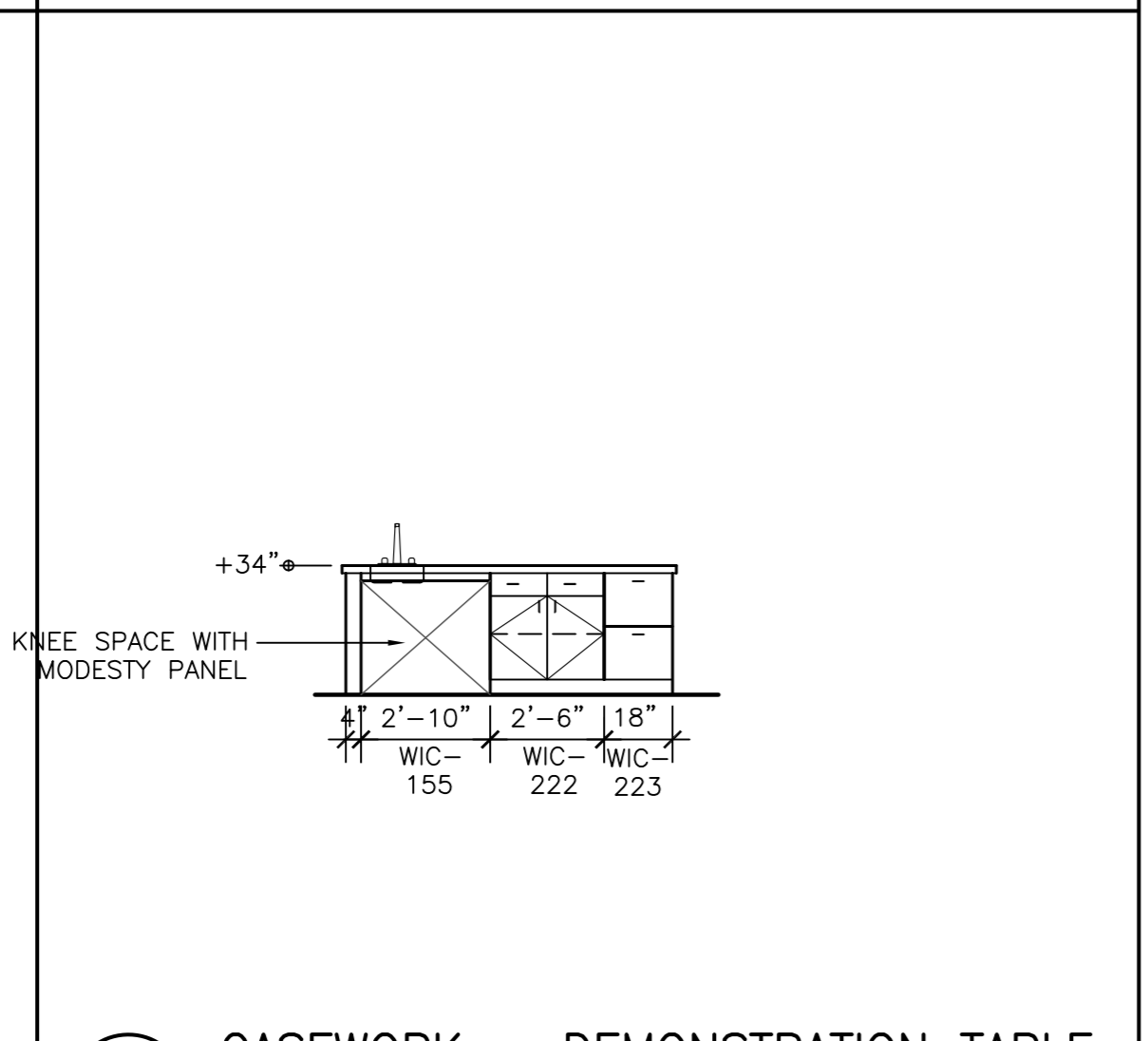
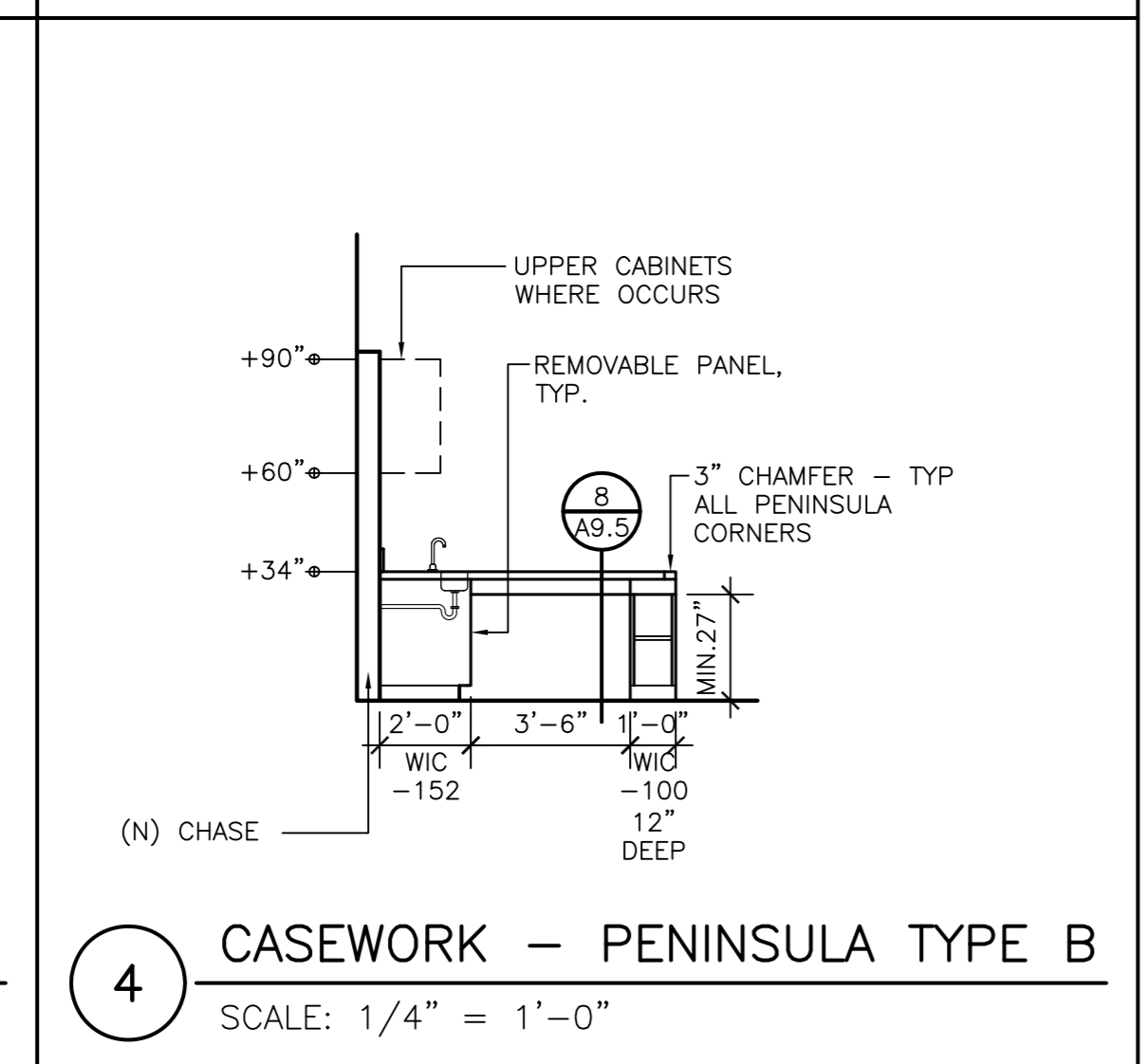
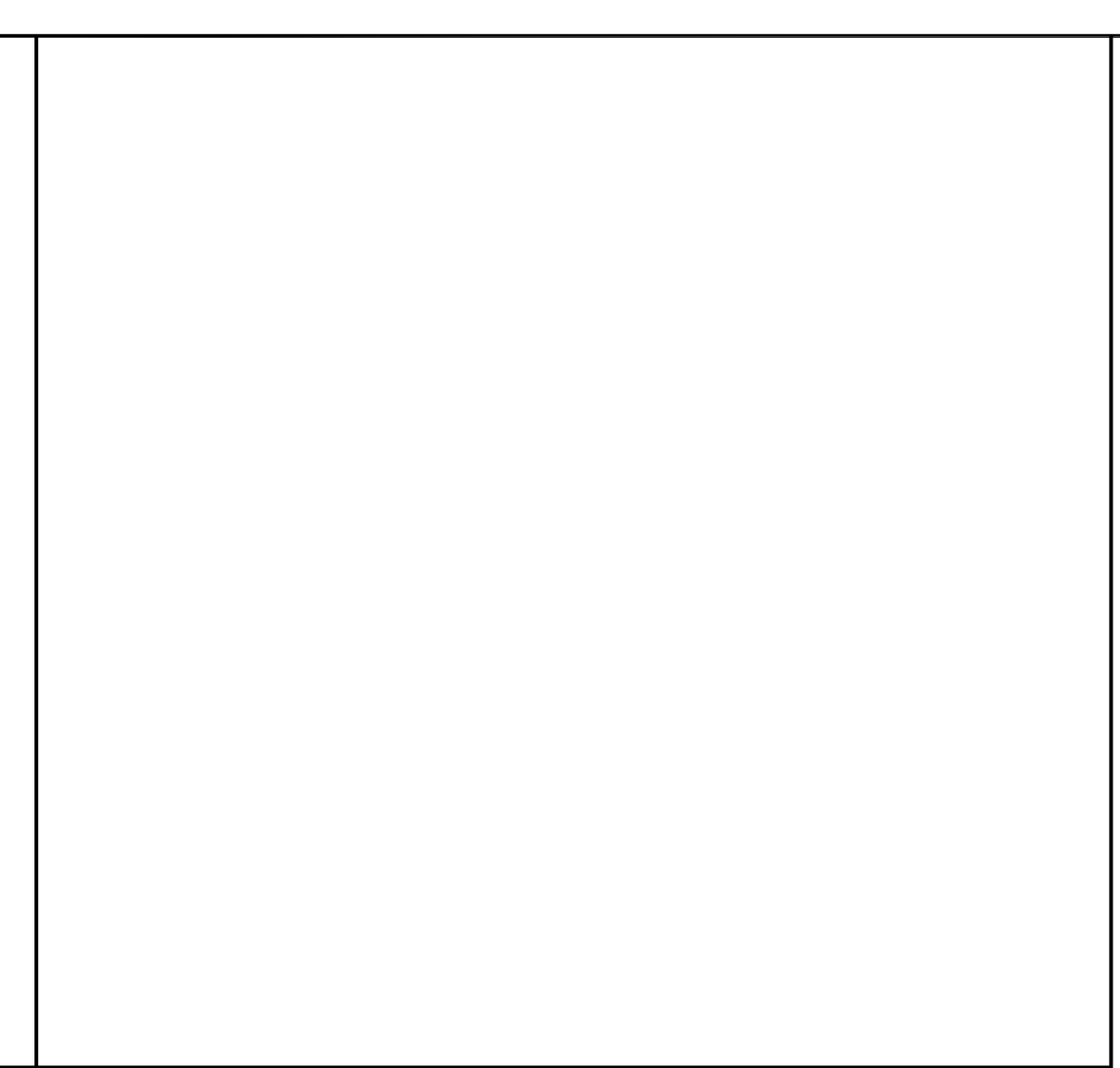
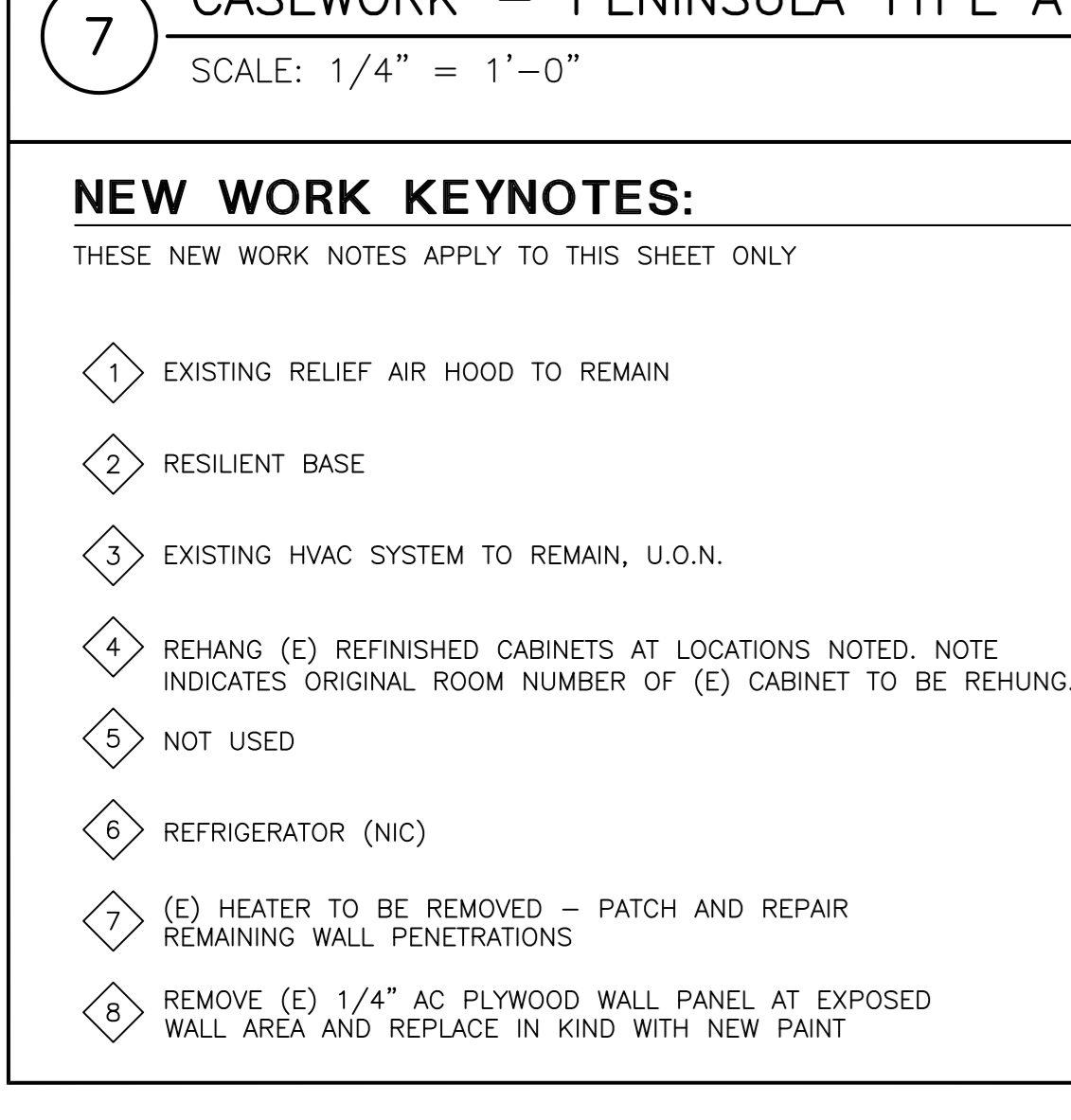
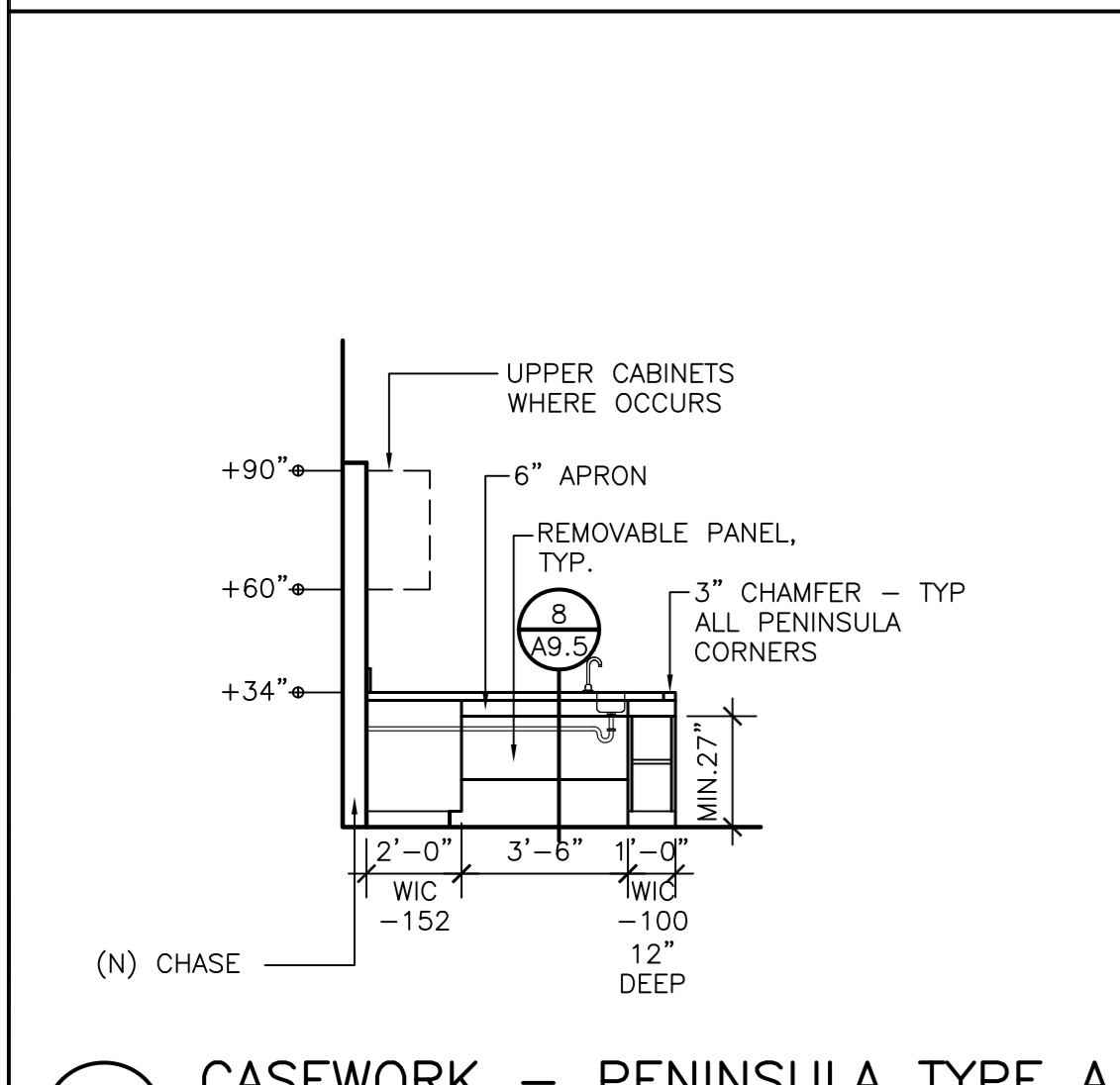
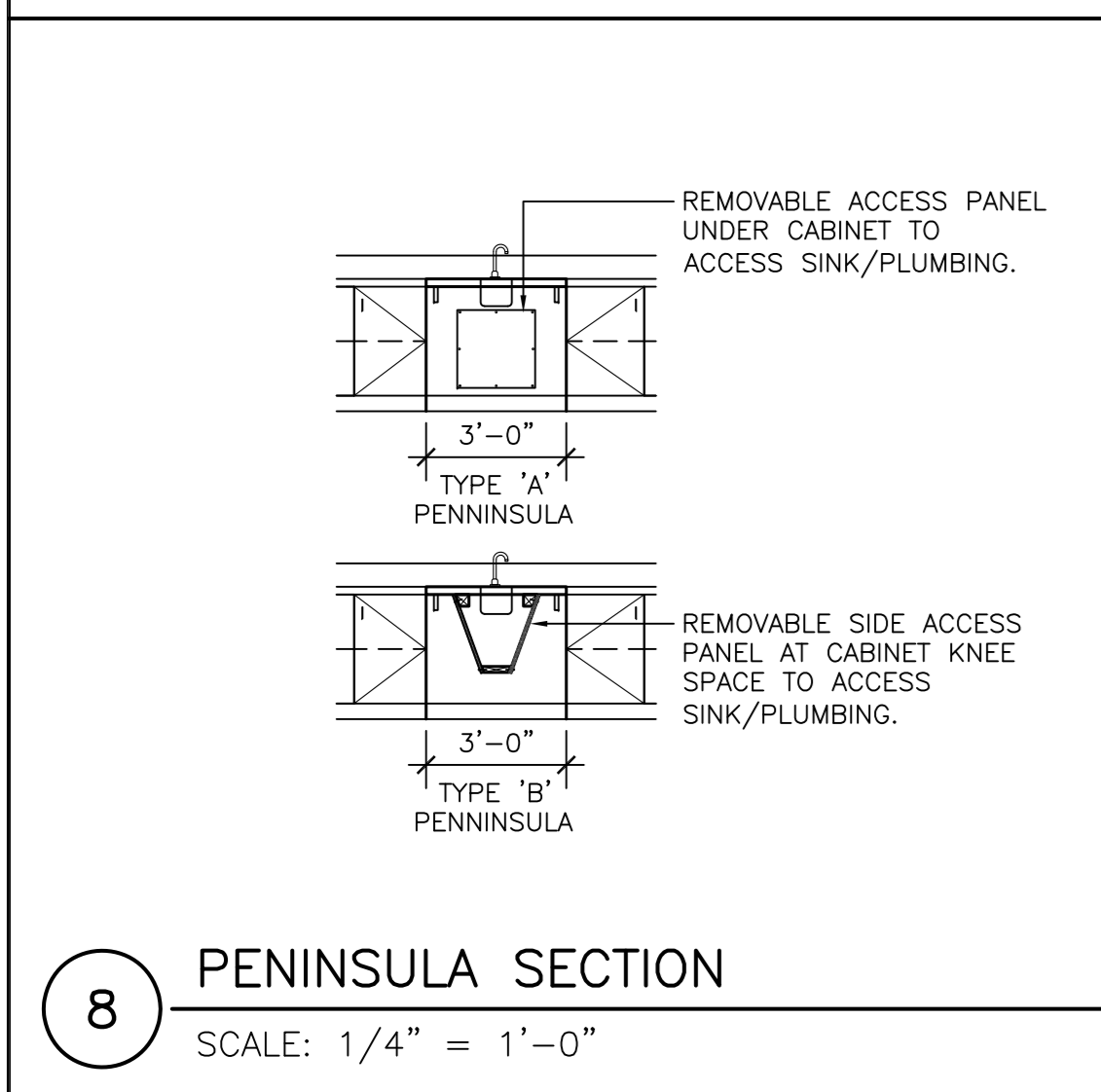
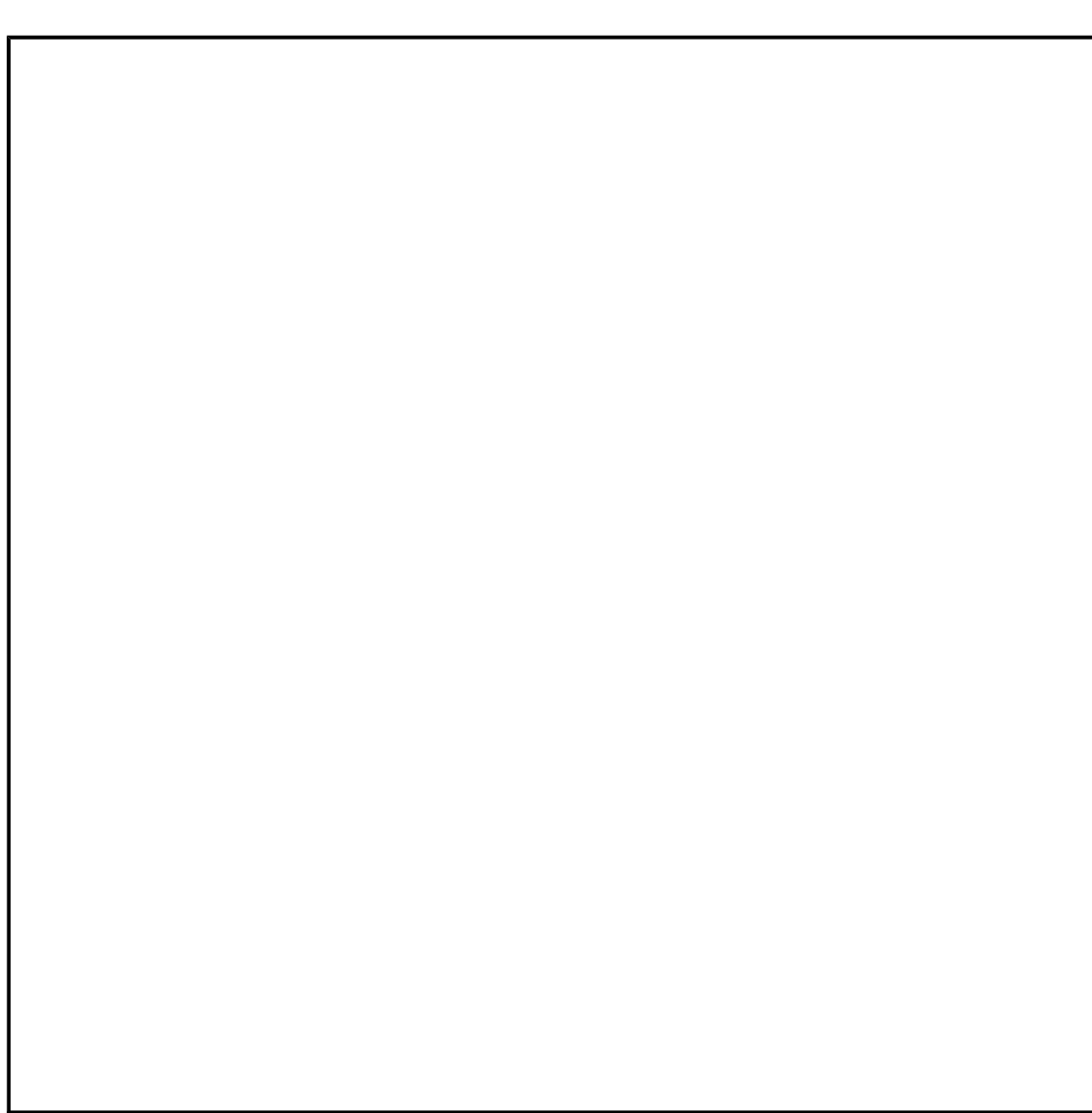

NEW WORK KEYNOTES:

- THESE NEW WORK NOTES APPLY TO THIS SHEET ONLY
- 1 EXISTING RELIEF AIR HOOD TO REMAIN
 - 2 RESILIENT BASE
 - 3 EXISTING HVAC SYSTEM TO REMAIN, U.O.N.
 - 4 REHANG (E) REFINISHED CABINETS AT LOCATIONS NOTED. NOTE INDICATES ORIGINAL ROOM NUMBER OF (E) CABINET TO BE REHUNG.
 - 5 NOT USED
 - 6 REFRIGERATOR (NIC)
 - 7 (E) HEATER TO BE REMOVED - PATCH AND REPAIR REMAINING WALL PENETRATIONS
 - 8 REMOVE (E) 1/4" AC PLYWOOD WALL PANEL AT EXPOSED WALL AREA AND REPLACE IN KIND WITH NEW PAINT
 - 9 INFILL OPENING(S) IN (E) WALL - TAPE AND TEXTURE TO MATCH (E). PAINT PER FINISH SCHEDULE
 - 10 REMOVE (E) TRANSFER GRILL - PATCH AND REPAIR OPENING
 - 11 PREP AND PAINT (E) WALL SURFACES AND WOOD WINDOW TRIM (WHERE OCCURS)
 - 12 REMOVE (E) TRANSFER GRILL - PATCH AND REPAIR OPENING
 - 13 BASE CABINET CONFIGURATION - PROVIDE NEW RESILIENT BASE.
 - 14 DOOR/OPENING WALL INFILL
 - 15 GAS SHUT-OFF VALVE WITH SURFACE MOUNTED GAS PIPING. SCRIBE VINYL TACK BOARD TIGHT TO PIPE AND VALVE BOX.
 - 16 PROVIDE SIDE SPLASH
 - 17 FILLER PANEL
 - 18 PLASTIC LAMINATE APRON - 27" MIN. CLR. TYP.
 - 19 PEG RACK - SEE SPEC SECTION 10 00 00.
 - 20 FUME HOOD BASE TOP CONFIGURATION: - PROVIDE DISHED WORK SURFACE WITH LEFT FRONT CUP SINK, MODEL No. 20L17300 BY THERMO SCIENTIFIC HAMILTON OR EQUAL. - PROVIDE POLYOLEFIN CUPSINK MODEL No. 34113700 BY THERMO SCIENTIFIC HAMILTON OR EQUAL. - PROVIDE NEW RESILIENT BASE.
 - 21 NEW PAINTED WOOD TRIM - SEE DETAIL 25/AB.3
 - 22 NEW VINYL WRAPPED TACK PANEL
 - 23 NEW PROJECTION SCREEN - SEE 29/AB.3 FOR MOUNTING DETAIL, TYP
 - 24 NEW MARKER BOARD - SEE SPEC SECTION 10 11 00
 - 25 FIRE BLANKET
 - 26 FIRE EXTINGUISHER
 - 27 NEW EXTERIOR WINDOW SYSTEM
 - 28 FIRE EXTINGUISHER
 - 29 NEW EXTERIOR WINDOW SYSTEM
 - 30 NEW UTILITY CHASE TYPE "A" - SEE DETAIL 6/AB.3
 - 31 NEW UTILITY CHASE TYPE "B" - SEE DETAIL 7/AB.3

GENERAL NOTES

1. CASEWORK MANUFACTURER SHALL NOTE ATTACHMENT DETAIL AND MAKE ACCOMMODATIONS FOR WALL LEDGERS AND SUB-TOP IN CASEWORK FABRICATION.
2. AT ALL FREE-STANDING VERTICAL CASEWORK LEGS, PROVIDE (1) ANGLE CLIP SIMILAR TO DETAIL 3/AB.0 AT FRONT AND REAR OF LEG WITH 1/4" X 2" EXPANSION BOLT INTO CONCRETE FLOORING.
3. AT ALL LOCATIONS WHERE NEW CABINET COUNTERTOPS DO NOT ALIGN WITH EXISTING COUNTERTOPS, PROVIDE VERTICAL TRANSITION COUNTERTOP PIECE.
4. SEE FLOOR PLANS AND FINISH SCHEDULE FOR ITEMS NOT NOTED ON ELEVATIONS.
5. SEE DETAIL 26 FOR EQUIPMENT MOUNTING HEIGHTS. SEE FLOOR 26/AB.3 PLANS FOR LOCATIONS.
6. SEE SHEET AB.0 FOR CASEWORK DETAILS.
7. PAINT ALL EXPOSED INTERIOR WALL AND WINDOW TRIM SURFACES THROUGHOUT ALL LABS AND WORKROOMS. PATCH AND REPAIR SURFACES PRIOR TO PAINT.
8. ALL FINISH KEYNOTES INDICATED HERE SHALL BE CONSIDERED TYPICAL THROUGHOUT FOR SIMILAR CONDITIONS IF SHOWN OR NOT OTHERWISE NOTED. SEE FINISH SCHEDULE FOR ADDITIONAL FINISH INFORMATION THAT MAY NOT BE SHOWN HERE.
9. WHERE NEW VINYL WRAPPED TACK PANELS OCCUR, ALL NEW EQUIPMENT ITEMS SHALL BE SURFACE MOUNTED OVER NEW PANELS.
10. AT ALL EXISTING UPPER CABINETS SHOWN TO BE REINSTALLED: CLEAN ALL SURFACES WITH MILD SOLUTION OF TSP. SAND/SCUFF ALL SURFACES OF EXTERIOR BODY OF CABINETS AND PROVIDE A CLEAR SATIN SEALER. INTERIOR OF CABINET SHALL REMAIN AS IS.
11. AT ALL EXISTING UPPER CABINETS SHOWN TO BE REINSTALLED: REPLACE ALL EXTERIOR PULLS WITH SAME TYPE BEING USED ON NEW CASEWORK.
12. AT ALL EXISTING UPPER CABINETS SHOWN TO BE REINSTALLED: REPLACE ALL CYLINDER LOCKS WITH NEW TO MATCH NEW CASEWORK LOCKS.
13. ALL NEW CASEWORK DRAWERS AND DOORS SHALL HAVE PULLS & LOCKS PER SPECIFICATION SECTION 06 41 16.

Mt. Diablo High School
Building S - Science Lab Modernization
 2480 Grant Street
 Concord, California 94520
Mt. Diablo Unified School District

MDUSD

 DIVISION OF THE STATE ARCHITECT
 revision date: _____ by: _____

FILE NO. XX-XX
 IDENTIFICATION STAMP
 DIV. OF THE STATE ARCHITECT
 OFFICE OF REGULATION SERVICES
 APPLICATION NO. 01-
 AC. FLS. SS.
 DATE _____

CONSULTANT
nacht&lewis
 600 Q Street, Suite 100
 Sacramento, CA 95811
 www.nachtandlewis.com
 916.329.4000

ARCHITECT
REVISIONS

NO.	DESCRIPTION	DATE	REV'D

DATE February 19, 2012
 JOB NO. Y1211.00
 SHEET TITLE
**Interior Elevations/
 Casework
 Details**
 SHEET NO. _____
A9.5
 SHEET _____ OF _____ TOTAL
DSA SUBMITTAL SET

ONE AND ONE-HALF INCH = ONE FOOT

ONE INCH = ONE FOOT

THREE-QUARTERS INCH = ONE FOOT

ONE-HALF INCH = ONE FOOT

ONE-QUARTER INCH = ONE FOOT

ONE-EIGHTH INCH = ONE FOOT

ONE-SIXTEENTH INCH = ONE FOOT

ONE INCH = TWENTY FEET

♦ NAILING NOTES:

- All nails for structural work shall be common wire nails unless noted otherwise.
- Nails shall be spaced not less than 11 diameters on center. Edge or end distances shall not be less than 6 diameters. Nail holes shall be sub-drilled where necessary to prevent splitting of wood. Sub-drill not to exceed 1/4 of the shank diameter.
- Where plaster or gyp. bd. ceilings occur, ceiling stripping nails shall be annular grooved shanks, "stronghold" or approved equal. Use 2-16d min. at each contact.
- Nailing not noted on this sheet or on details elsewhere, shall be a minimum of 2 nails at each contact using 8d nails thru 1x's and 16d thru 2x's.
- Minimum nailing shall be:
 - A. Studs and posts @ top and bottom to bearing:
 - 2x6 and smaller..... 2-8d TN, ea side or 3-16d end nails
 - 2x8..... 3-8d TN, ea side or 4-16d end nails
 - 2x10 and larger..... 4-8d TN, ea side or 5-16d end nails
 - 3x6 (sub-drill)..... 3-8d TN, ea side or 4-20d end nails
 - 3x8 and larger (sub-drill)..... 4-8d TN, ea side or 5-20d end nails
 - B. Joists or rafters:
 - to side of stud up to 8"..... 3-16d each additional 4"..... 1-16d additional to bearing..... 2-10d TN, ea side at laps (2" minimum)..... 4-16d
 - C. Blocking:
 - to joists, rafters or blk..... 2-10d TN, ea side, ea end, staggered
 - to studs..... 2-10d TN or 2-16d ea end
 - D. Sheathing:
 - floor - 3/4" plywood..... 10d at 6"cc at edges of sheets and over all walls (SPFN), 10d at 12"cc at all interior contacts (SPIN)
 - wall - 1/2" plywood..... 8d at 3"cc at edges of sheets and holdown studs (SPFN), 8d at 12"cc at all interior contacts (SPIN)
 - roof - 1/2 or 5/8" plywood..... 8d at 3"cc at edges of sheets and over all walls (SPFN) 8d at 12"cc at all interior contacts (SPIN)
 - E. Ribbons and ledgers to studs:
 - 1x ribbons..... 2-8d ea stud
 - 2x ribbons..... 2-16d ea stud
 - 2x ledgers..... 2-16d ea stud
 - 3x ledgers..... 2-40d ea stud
 - F. Double top plates:
 - upper plate to lower plate..... 16d at 16"cc stagr corner or intersection..... 3-16d
 - G. Minimum plate laps:
 - 12-16d ea side
 - H. Multiple studs:
 - stagr for over 4" widths..... 16d at 12"cc
 - I. Built-up beams:
 - 10" or less..... 16d at 12"cc stagr (2x)
 - more than 10"..... 1/2" dia bolts at 24"cc
 - J. Double joists:
 - not blocked apart..... 16d at 12"cc stagr blocked apart with 2x T&G decking..... 2-20d ea end, ea block
 - K. nailing:
 - 1-16d straight nail and 1-16d slant nail thru tongue.
- At metal strap ties, fill all holes with nails UNO. Use nail size & type as specified in allowable load table in Simpson catalog C2011. Where two sizes are given, use larger size.
- All nails exposed to weather shall be hot dipped galvanized. All nails driven into pressure treated wood shall be hot dipped galvanized.

♦ DRILLED-IN ANCHORS - INSTALLATION & TESTING:

- Anchor shall be installed in accordance with the recommendations given in the ICC reports listed below and the manufacturer's instructions.
 - Expansion Anchors:
 - A. Hilti Kwik Bolt TZ (KB TZ), ESR-1917
 - B. To CMU..... Hilti Kwik Bolt 3 (KB 3), ESR-1385
 - Epoxy Anchors:
 - A. Simpson SET-XP, ESR-2508
 - B. To CMU..... Hilti HIT HY 150 MAX, ESR-1967
- Anchor shall be tested per all applicable requirements of the 2010 CBC and DSA IR19-1.
- The following criteria apply for the acceptance of installed anchors.
 - A. Hydraulic Ram Method: The anchor should have no observable movement at the applicable test load. For wedge type anchors, a practical way to determine observable movement is that the washer under the nut becomes loose.
 - B. Torque Wrench Method: The applicable test for torque must be reached within 1/2-turn of the nut.
- All anchors used in structural applications shall be tested. 50% of all anchors used in non-structural applications shall be tested per CBC Section 1916A.7. If any anchor fails the test, all anchors of the same type not previously tested shall be tested until 20 consecutive anchors pass, then resume initial testing frequency.
- When installing drilled-in anchors in existing concrete or masonry, do not cut or damage existing reinforcing bars.
- The testing of the anchors shall be done by the testing laboratory and a report of the test results shall be submitted to DSA and the Architect/Structural Engineer.
- Substitution of an alternative manufacturer is subject to the approval of the Structural Engineer of Record and DSA.
- Test expansion anchors to values listed below. Contact Structural Engineer for epoxy anchor test values and procedures.
- Test equipment (including torque wrenches) is to be calibrated by an approved testing laboratory in accordance with standard recognized procedures.
- Testing shall occur at a minimum of 24-hours after the installation of the anchors.
- All tests shall be performed in the presence of a Special Inspector per CBC Section 1916A.7.
- Test proof loads for repair conditions are not part of these documents and will require a separate approval by the Structural Engineer of Record and DSA.

Hilti KB TZ ESR-1917	Minimum Embed (in)	Minimum Torque (Ft#)
3/8"ø	2 3/4	25
1/2"ø	3 3/4	40
5/8"ø	4 1/2	60
3/4"ø	5 3/4	110

* Unless noted otherwise on plan

♦ TESTS & INSPECTIONS:

- Tests and inspections shall be provided for Davis Elementary and Heritage Elementary campuses by the Testing Laboratory as marked below and shall conform to the requirements of the 2010 CBC, Section 1701A. Reference the DSA T&I Form 103 in the Project Specifications for a summary of tests and inspections required for the campuses in this project.

Tests: <input type="checkbox"/> Fill Compaction <input type="checkbox"/> Reinforcing Steel <input checked="" type="checkbox"/> Concrete Compression <input checked="" type="checkbox"/> Structural Steel (Unidentified) <input checked="" type="checkbox"/> Expansion & Epoxy Anchors <input type="checkbox"/> Masonry <input type="checkbox"/> Grout and Mortar	Inspections: <input type="checkbox"/> Footing Excavation <input type="checkbox"/> Pile/Pier Installation <input checked="" type="checkbox"/> Reinforcement Placement <input checked="" type="checkbox"/> Concrete Mix Designs <input checked="" type="checkbox"/> Batch Plant (first batch only) <input type="checkbox"/> Structural Shop Welding <input type="checkbox"/> Structural Field Welding <input type="checkbox"/> Welder Qualifications <input type="checkbox"/> Masonry Placement & Grouting <input type="checkbox"/> Shear Stud Installation
--	--

♦ GENERAL NOTES:

- All construction shall conform to the 2010, Title 24 of the California Code of Regulations and all other applicable codes and regulations.
- Details and notes shown are typical and shall apply unless noted otherwise in the contract documents.
- If conflicting information is shown on construction documents, the more restrictive requirement shall apply.
- Overall wall dimensions are typically from 1/2 of wall to 1/2 of wall at steel framed buildings and from face of wall to face of wall at wood framed buildings, concrete tilt-up and CMU buildings.
- Contractor shall verify all dimensions and elevations on the job including existing construction.
- Prior to fabrication, shop drawings shall be submitted to the Structural Engineer for review.
 - A. Shop drawings: Contractor agrees that shop drawings submitted processed by the Engineer are not change orders and that the purpose of shop drawing submittals by the Contractor is to demonstrate to the Engineer that the Contractor understands the design intent by indicating which material he intends to furnish and install and by detailing the fabrication and installation method he intends to use.
- Contractor shall verify all dimensions, elevations, and property lines etc. on the job.
- Contractor shall notify the Architect and Structural Engineer where a conflict occurs on any of the contract drawings or documents. Contractor is not to order material or construct any portion of the building that is in conflict, until conflict is resolved with the affected parties.
- Contractor shall be responsible for the design and construction of all foundation forms and shoring.

♦ REMODELING AND ADDITION NOTES:

- It shall be the Contractor's responsibility to make himself familiar with all existing conditions, any existing building plans, and all site conditions which may affect his work. He shall ascertain the extent of demolition work required to complete the structure per new plans and be responsible for its safe completion.
- When existing building plans are available, the Contractor shall keep a full set of such plans at the job site during construction. If any existing conditions are discovered which deviate from these plans or from the new plans, the contractor shall notify the Architect and Structural Engineer for instruction prior to proceeding with work in the affected area.
- The Contractor shall match existing heights, lines, materials, and conditions unless noted otherwise on new plans.

♦ CONCRETE & REINFORCING STEEL NOTES:

- Concrete construction shall conform to ACI 318-08.
- The minimum 28 day strength and type of concrete shall be as follows:
 - A. Lean concrete fill..... 1,500 psi (150 pcf)
 - B. Slabs on the grade..... 4,000 psi (150 pcf)
 - C. Tie beams and foundations..... 3,500 psi (150 pcf)
 - D. Exterior slabs and walks..... 3,000 psi (150 pcf)
 - E. Cast-in-place column..... 4,000 psi (150 pcf)
- Cement shall conform to ASTM C-150, type 1 or II.
- Concrete Aggregate: Natural sand and aggregate shall conform to ASTM C-33.
- Reinforcing steel shall conform to ASTM A615 Grade 60, UNO.
- Welding of reinforcing steel shall conform to AWS D1.4 strictly proper low hydrogen electrodes. Tack welding to rebar is strictly prohibited. See "Rebar Welding Notes."
- Reinforcing steel shall be fabricated and installed according to Manual of Standard Practice of Reinforced Concrete Construction by the Concrete Reinforcing Steel Institute.
- Wire fabric shall conform to ASTM A-185.
- Dimensions shown below for location of reinforcing are to the face of reinforcing and denote clear coverage. Concrete coverage shall be as follows UNO on drawings.
 - A. Concrete deposited directly against ground
except slabs..... 3" forms..... 2"
 - C. Slabs on the ground..... position in center of slab.
- Lap splices in concrete: 69 bar dia, 36" min, unless otherwise shown for #6 bars and smaller, 86 bar dia min for #7 and larger bars. Splices in adjacent bars shall be at least 5'-0" apart. Bars may be wired together at splices or laps.
 - A. No pipes or ducts shall be placed in concrete slabs or walls unless specifically detailed on the Structural drawings.
 - B. Refer to Architectural, Structural, Civil, Electrical and Mechanical drawings for all molds grooves or ornaments clips and grounds to be cast in concrete.
- The exposed concrete face at a horizontal construction joint shall be kept continuously moist from time of initial set until placing of concrete. Thoroughly clean contact surface by chipping entire surface not earlier than 5 days after initial pour to expose clean, hard aggregate solidly embedded, or by an approved method that will ensure equal bond, such as green cutting, if contact surface becomes coated with earth, sawdust, etc. after being cleaned, rechip entire surface.
- Remove all debris from the forms before placing any concrete.
- Reinforcing dowels, bolts, anchors sleeves etc. to be embedded in concrete shall be securely positioned before placing concrete. Obtain approval of all affected trades prior to placing concrete.
- Maximum free fall on concrete should be 4'-0". If necessary, provide openings in forms to reduce fall.
- No wood spreaders or wood stakes allowed in areas to be concreted.
- Concrete mix design shall be prepared by an independent laboratory approved by the school district.
- Notify the Structural Engineer 48 hours prior to placing concrete.
- Reinforcing steel not specifically detailed shall be per ACI-318-2008 Detailing Manual.

♦ CARPENTRY NOTES:

- Stagger anchor bolts on sill 6" & wider. For "shot" sills, see details. Use 2 1/2" edge disance on staggered bolts.
- All wood sills to be pressure treated douglas fir. If bolted, use 1/2" dia x 12" bolts (18" at curb) placed not more than 9" nor less than 4 1/2" from ends of sill pieces and not over 4'-0"cc between bolts. Holes over 1/2" E width and notches in sills are considered ends. Use 2-anchor bolts minimum per sill E.
- All studs shall be 2x6 at 16"cc unless noted otherwise.
- Provide continuous 2x stud width blocking between studs at mid-height of stud or so spaced that the unbraced length of studs does not exceed 10'-0". Provide blocking in all walls at ceiling lines.
- Lap wall plates at corners and intersections.
- Provide 2x solid blocking between joists or rafters over supports.
- Bolt holes in wood or steel shall be 1/4" larger than bolt dia.
- All bolts, expansion anchors and lag screws shall be provided with metal washers under the heads and nuts which bear on wood. Lag screws and wood screws shall be screwed and not driven into place. All bolts and lag screws shall be tightened on installation and retightened before closing in or completion of the job.
- Provide shaped and dapped pieces as shown on drawings. Dap 1" max on 3x and larger members, no dap allowed in 2x members.
- Window and door frames shall be firmly secured in place to blocking between jambs and rough openings at top, bottom and at a maximum interval of 24" between. Nail blocking to rough frame with 16d finish nails at 6"cc staggered, set 1/4".
- All cabinets, lockers etc. shall be firmly secured in place by 4-8d minimum nails per stud thru plywood back except if cabinets are wall hung. #14 wood screws shall be used in place of nails penetrating the studs 2" minimum. (See Architectural drawings for additional anchorage details)
- No structural members shall be cut unless specifically detailed.

♦ BOLT AND WASHER NOTES:

- Provide washers under heads and nuts of all bolts and lags bearing against wood.
- Installation of bolts, lags, screws and washers shall be in accordance with Title 24 Section 2318A.
- Washers shall be square plate steel or round malleable iron:
 - A. 1/2"ø bolt..... 2"x2"x1/4" or 2 1/2"ø x 1/4"
 - B. 3/4"ø bolt..... 2 1/2"x2 1/2"x1/4" or 2 1/2"ø x 1/4"
 - C. 1"ø bolt..... 2 1/2"x2 1/2"x1/4" or 3"ø x 1/4"
 - D. 1 1/4"ø bolt..... 3 1/4"x3 1/4"x1/4" or 3 1/2"ø x 1/4"
 - E. 1 1/2"ø bolt..... 3 1/2"x3 1/2"x1/4" or 4"ø x 1/4"
 - F. Sill E ABs..... 3"x3"x1/4"
- All exposed washers shall be malleable iron. Upset (rolled) threads are not permitted.

♦ ABBREVIATIONS:

@	at	jt	joint
&	and	jst	joist
∠	angle	JH	Joist Hanger
abv	above		
addl	additional	llng	longitudinal
alt	alternate	LLH	Long Leg Horizontal
AB	Anchor Bolt	LLV	Long Leg Vertical
Arch	Architect/ural	LS	Lag Screw
AFF	Above Finish Floor	lt	light
agg	aggregate	MB	Machine Bolt
		MC	Moisture Content
bm	beam	mfr	manufacture/d/r
blw	below	mox	maximum
blk	block	mech	Mechanical
blkg	blocking	met	metal
bot	bottom	mezz	mezzanine
B.O.	Bottom Of (Conc. Flg. etc)	NA	Neutral Axis
bdg	building	nom	nominal
btwn	between	(N)	New
bv	beveled	NTS	Not To Scale
brg	bracing	#	number/pounds
brg	bearing	no	number
		opng	opening
CBC	California Building Code	OH	Opposite Hand
C	camber	OD	Outside Diameter
CIP	Cast In Place	ov	over
clq	ceiling		
cl	center line		
ctr	center to center		
ctd	centered		
c	channel		
clr	clear		
col	column		
conc	concrete		
CMU	Concrete Masonry Unit		
conn	connection		
CJ	Construction/Cold Joint		
cont	continuous		
Contr	contractor		
ctsk	countersink		
dn	down		
DF	douglas fir		
diag	diagonal		
Ø	diameter		
dim	dimension		
dbl	double		
dbs	diagonal sheathing		
DS	drawings		
ea	each		
EW	Each Way		
EF	Each Face		
ES	Each Side		
E.O.	Edge Of (Conc. Flg. etc)		
elec	electric/al		
elev	elevation		
embed	embedment		
EN	End Nail		
eq	equal		
(E)	Existing		
EJ	Expansion Joint		
ext	exterior		
F.O.	Face Of (Conc. Flg. etc)		
fin	finish		
FF	Finish Floor		
FHWS	Flat Head Wood Screw		
flr	floor		
ft	foot/feet		
ftg	footing		
frn	foundation		
frng	framing		
fab	fabricate/d		
FG	Finish Grade		
flg	flange		
ga	gauge		
galv	galvanized		
GL	Glu-lam		
gr	grade		
GT	Girder Truss		
gyp	Gypsum Wall Board		
hgr	hanger		
hbr	header		
ht	height		
HSB	High Strength Bolt		
HSS	Hollow Structural Shape		
HD	Hold Down		
horiz	horizontal		
info	headed Welded Stud		
hws	information		
ID	inside Diameter		
int	interior		

♦ SYMBOL LEGEND:

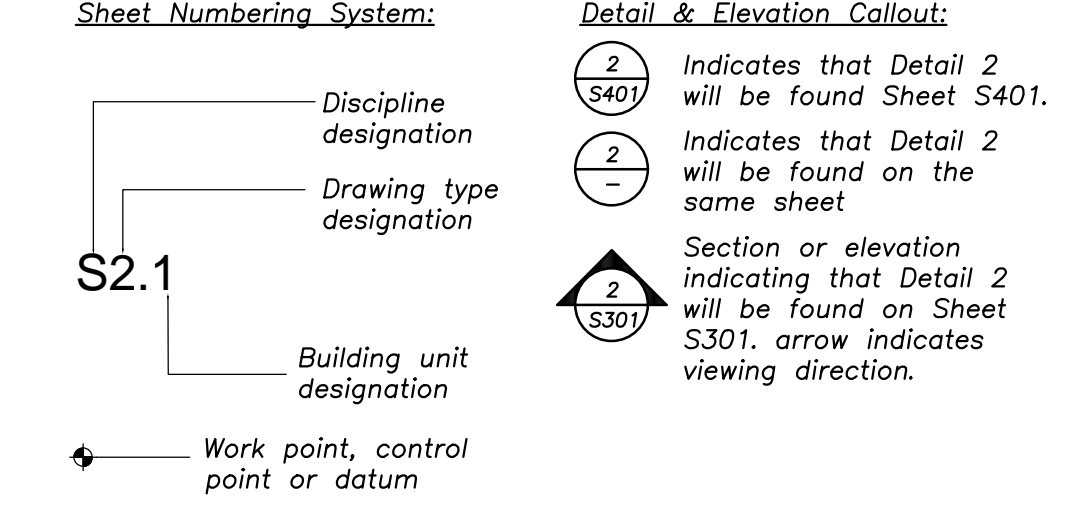

♦ MATERIAL LEGEND:

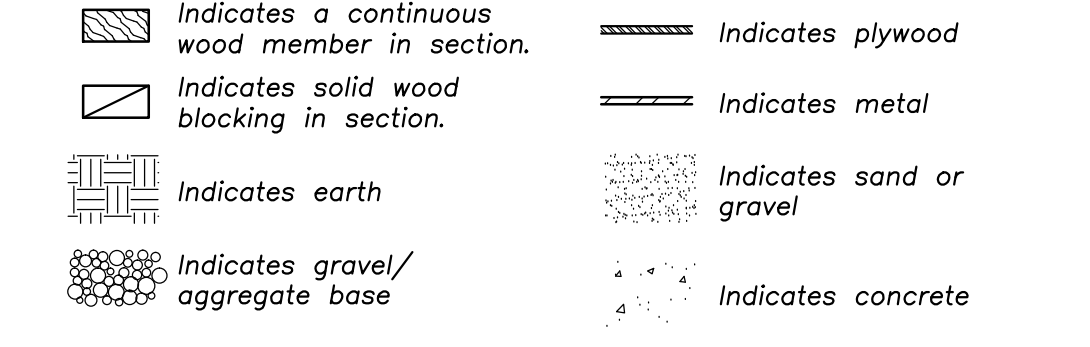



♦ DESIGN CRITERIA:

- Building Code: 2010 California Building Code
- Wind Loads:
 - Basic Wind Speed, V = 85 mph
 - Occupancy Category III, Iw = 1.15
 - Exposure Category = C
- Seismic Loads: Per ASCE 7-05 Section 12.8 (Equivalent Lateral Force Procedure)
 - Occupancy Category III, Is = 1.25
 - Ss = 0.694 S1 = 0.256
 - Site Class D
 - Sds = 0.576 Sd1 = 0.323
 - Seismic Design Category D
 - Wood Shear Walls, R = 6.5
 - V = (Cs)W = 0.115W
- Vertical Loads:
 - Roof dead load = 16 psf
 - Roof live load = 20 psf, reducible

Mt. Diablo High School
Building S - Science Lab Modernization

2450 Grant Street
Concord, California 94620

Mt. Diablo Unified School District

FILE NO. xx-xx
IDENTIFICATION STAMP
DIV. OF THE STATE ARCHITECT
OFFICE OF REGULATION SERVICES
APPLICATION NO.
01-
AC. FLS. \$8
DATE

DIVISION OF THE STATE ARCHITECT
revision date: by:

B (916) 418-9100
Sacramento, CA 95811
barrish.com

Barrish Pelham & Associates, Inc.
Consulting Engineers



CONSULTANT

nacht&lewis

600 Q Street, Suite 100
Sacramento, CA 95811
www.nachtlewis.com
916.329.4000

ARCHITECT

REVISIONS		
NO.	DESCRIPTION	DATE REV'D

DATE February 19, 2012
JOB NO. Y1211.00
SHEET TITLE

General Notes

SHEET NO.

S0.1

SHEET ___ OF ___ TOTAL
DSA SUBMITTAL SET

ONE AND ONE-HALF INCH = ONE FOOT
 ONE INCH = ONE FOOT
 THREE-QUARTERS INCH = ONE FOOT
 ONE-HALF INCH = ONE FOOT
 ONE-QUARTER INCH = ONE FOOT
 ONE-EIGHTH INCH = ONE FOOT
 ONE-SIXTEENTH INCH = ONE FOOT
 ONE INCH = TWENTY FEET

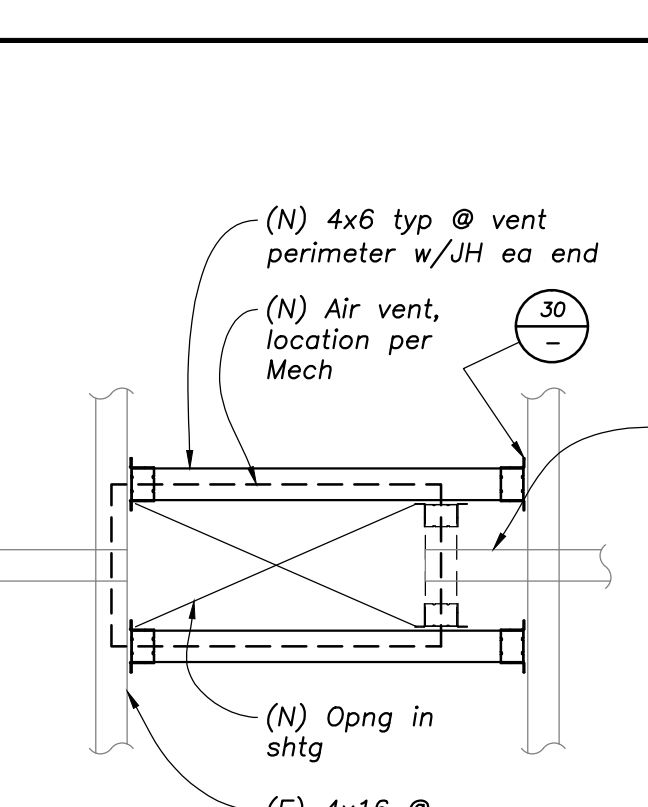

TYPICAL BLOCKING @ ROOF AIR VENT 30

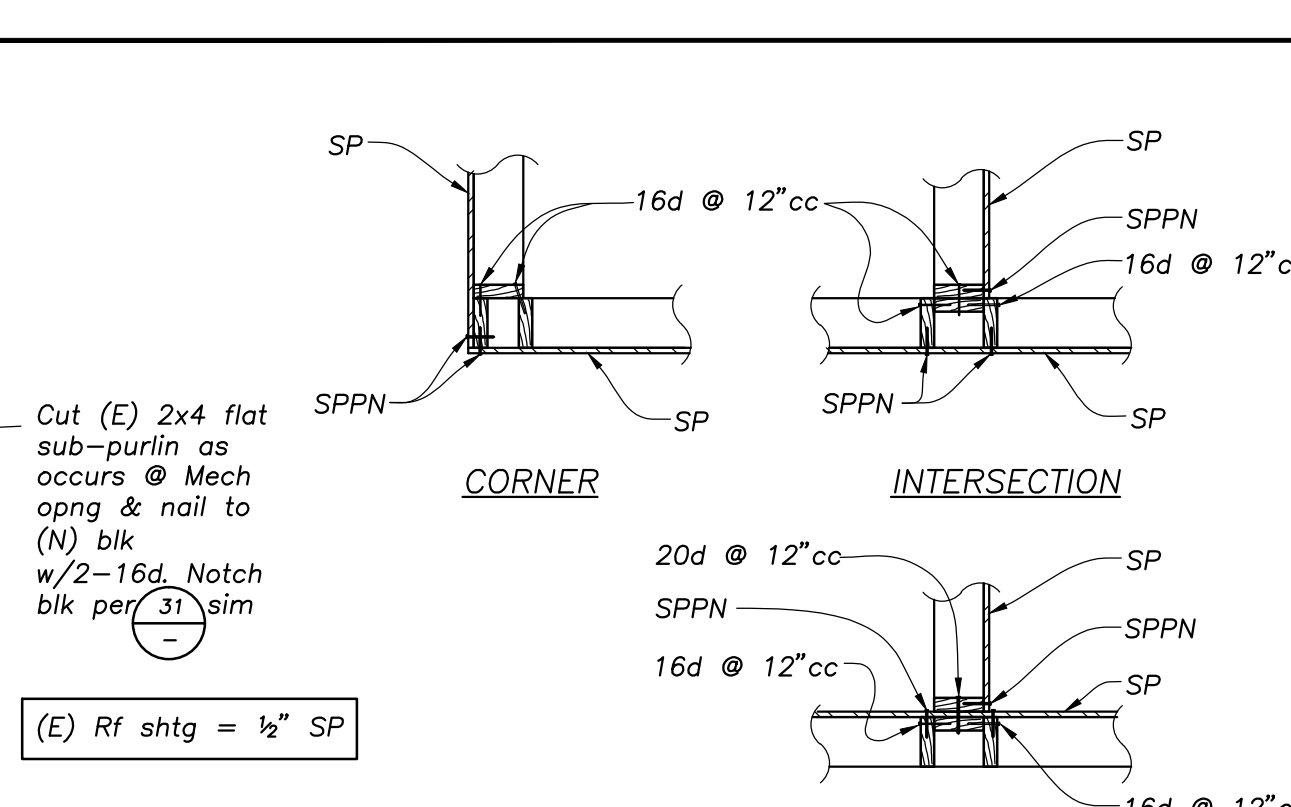

SHEATHED STUD WALL FRAMING DETAILS 25

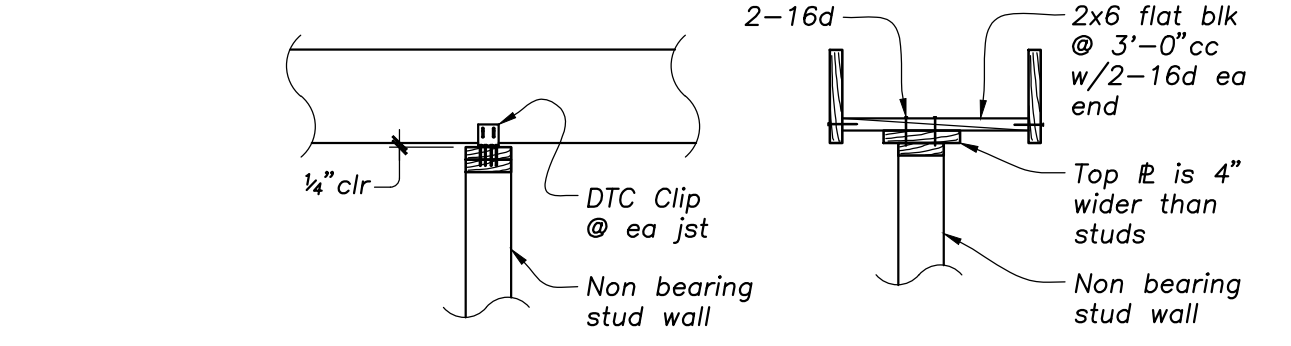

NON-BEARING WALL TO JOISTS 26

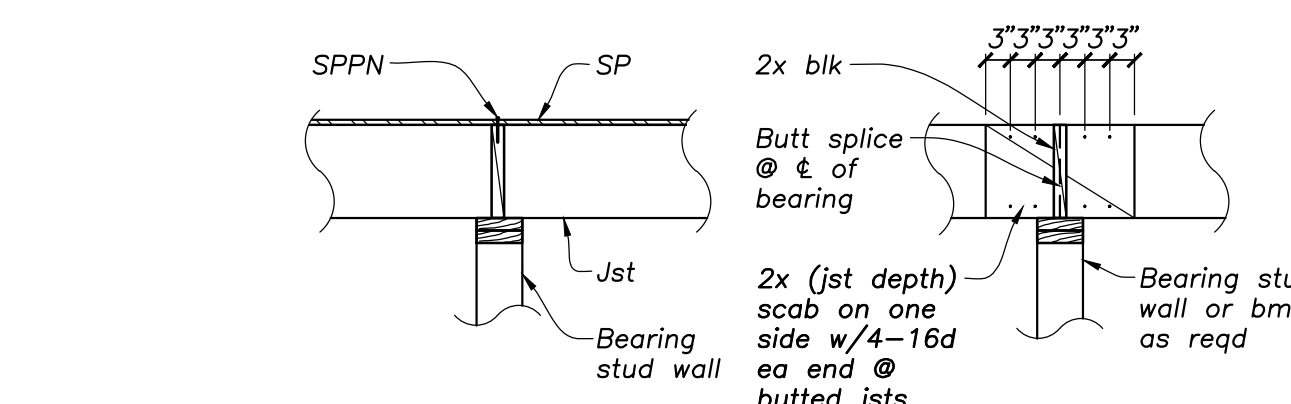

BEARING WALL TO JOISTS 27

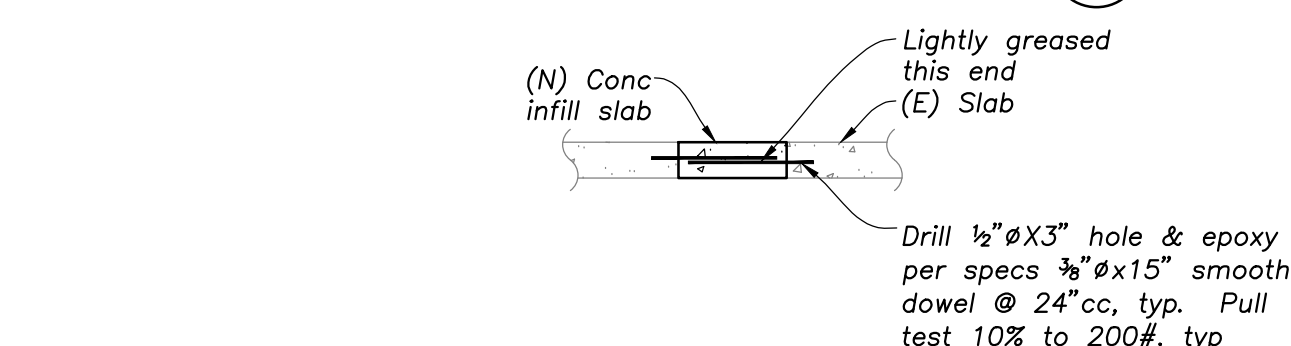

(N) UTILITY TRENCH THRU (E) SLAB 28

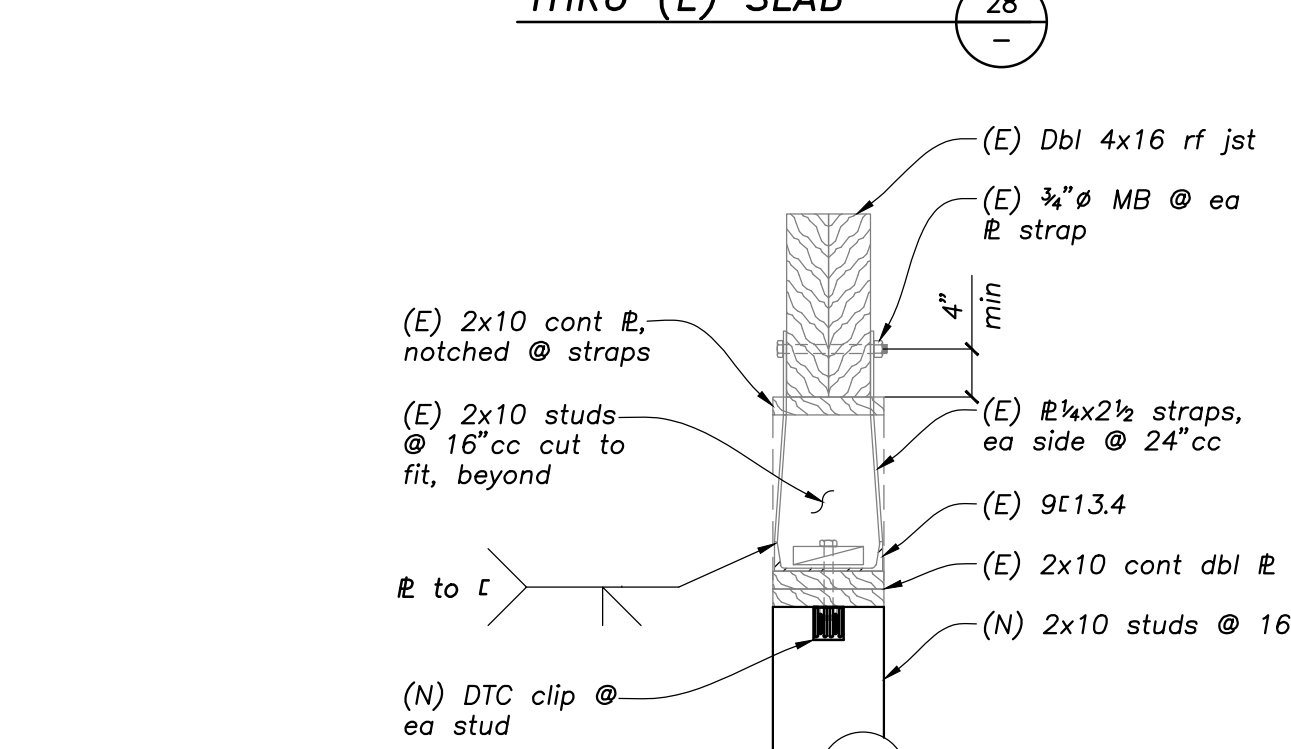

(N) INFILL WALL @ (E) FOLDING PARTITION 29

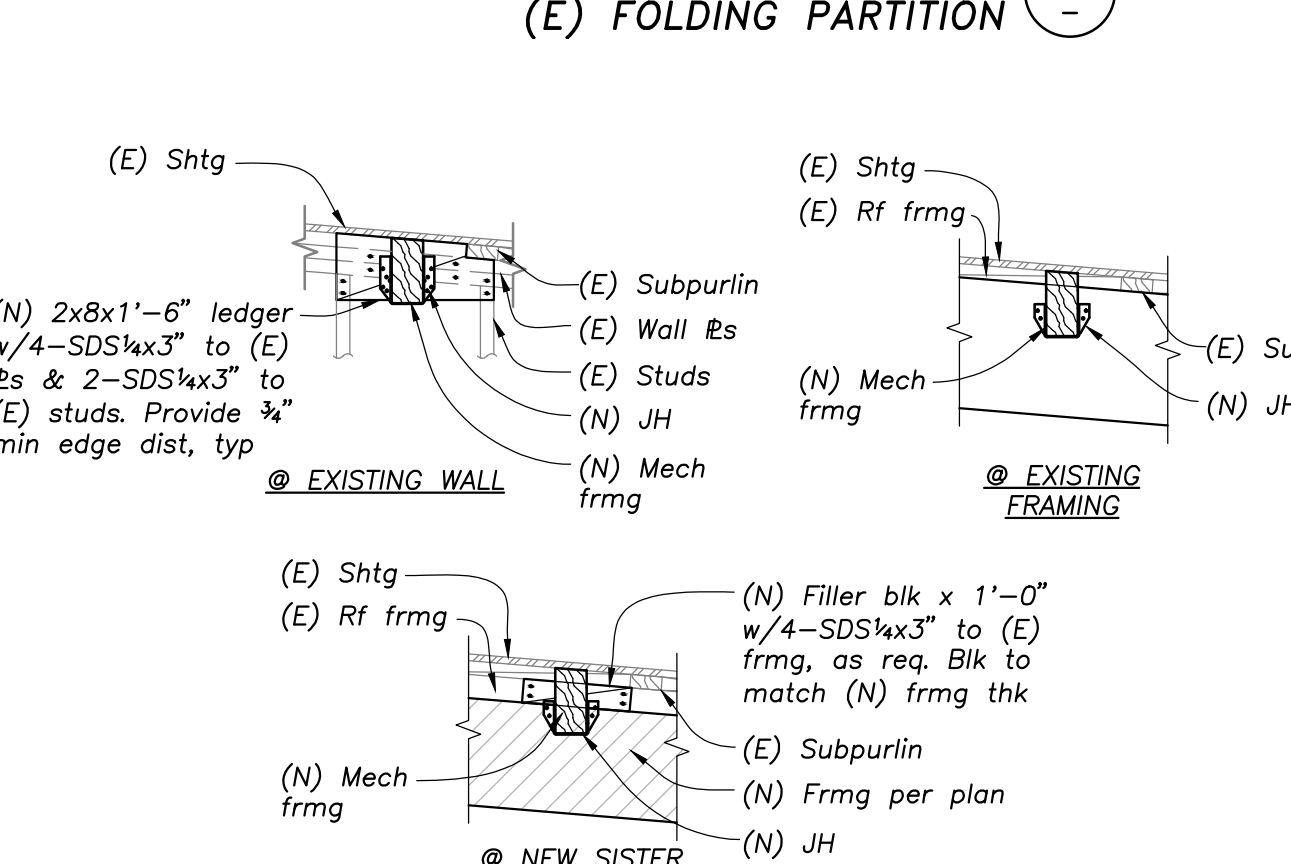

TYPICAL BLOCKING BELOW MECH UNIT 30

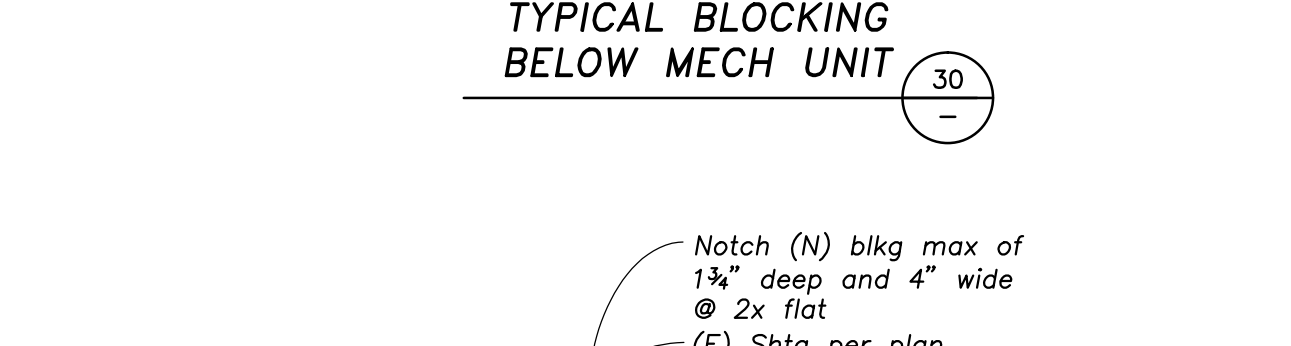

TYPICAL BLOCKING @ SUBPURLINS 31

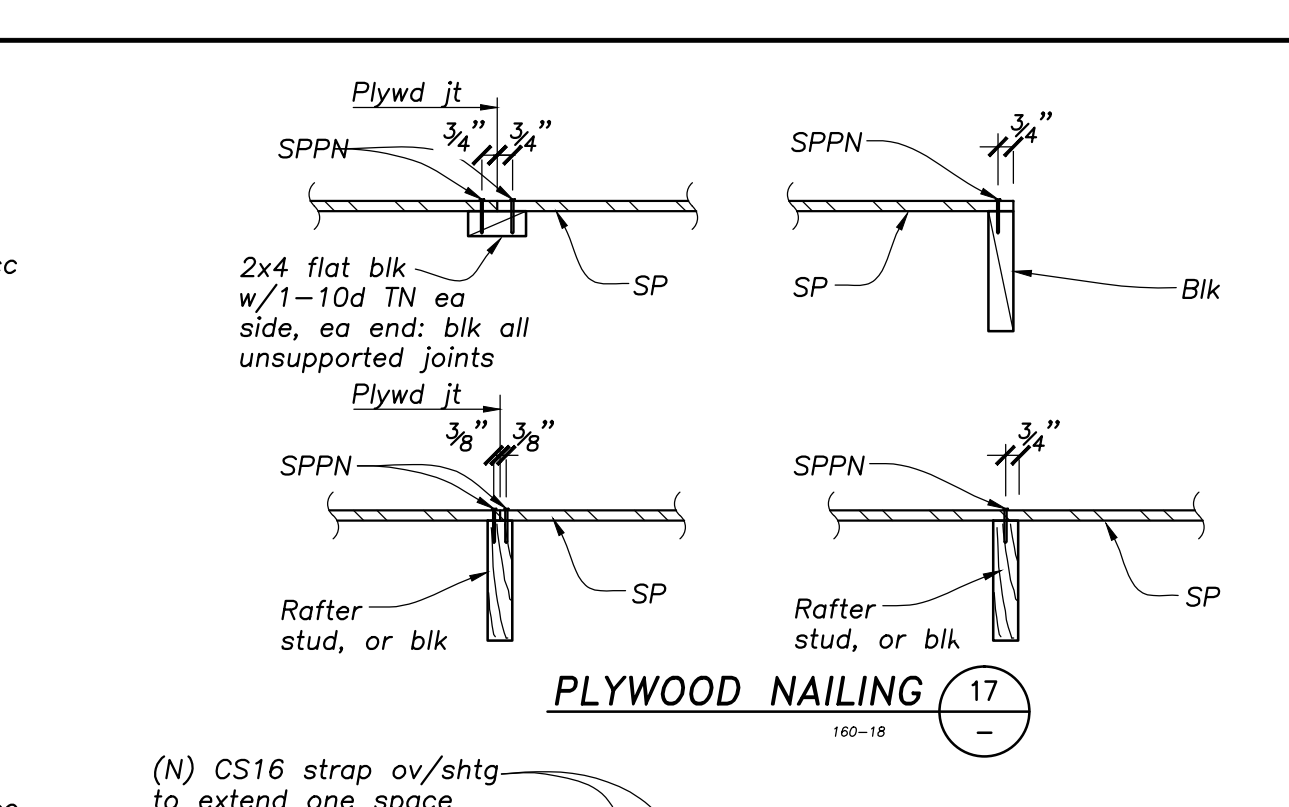

PLYWOOD NAILING 17

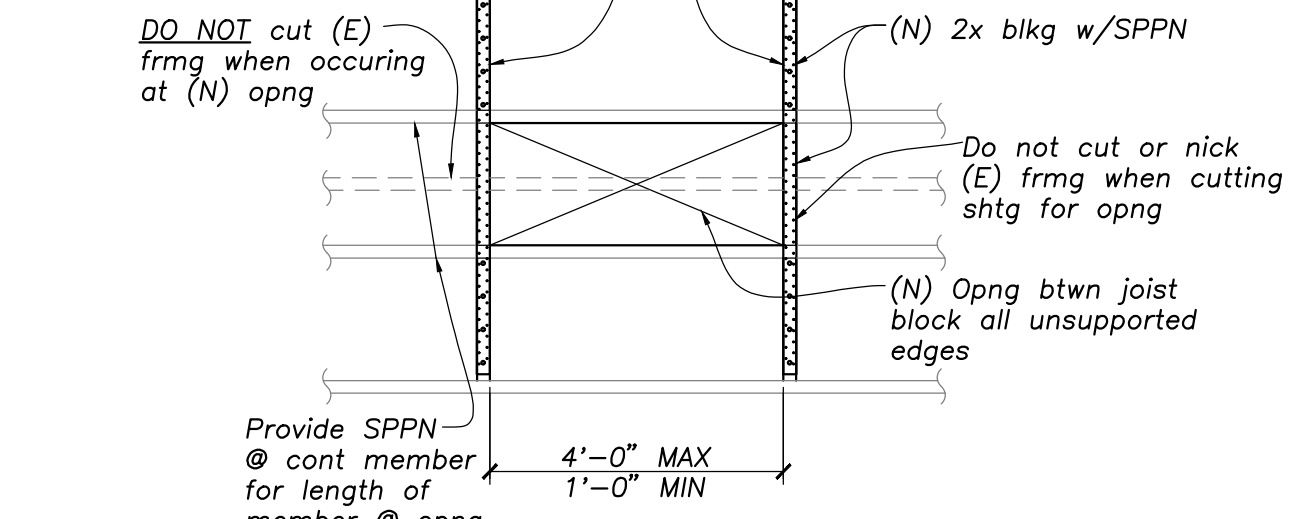

ROOF OPENING 18

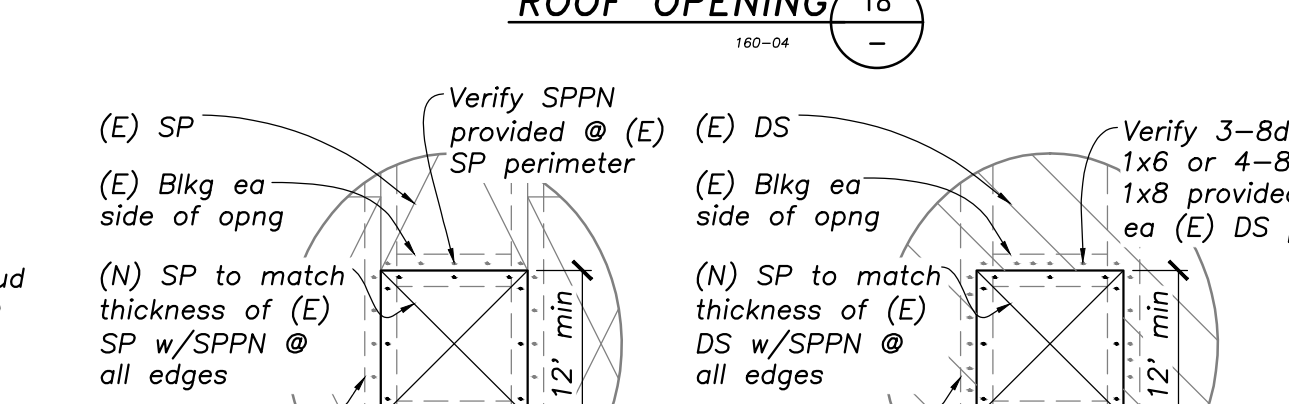

SP INFILL @ EXISTING OPENING 19

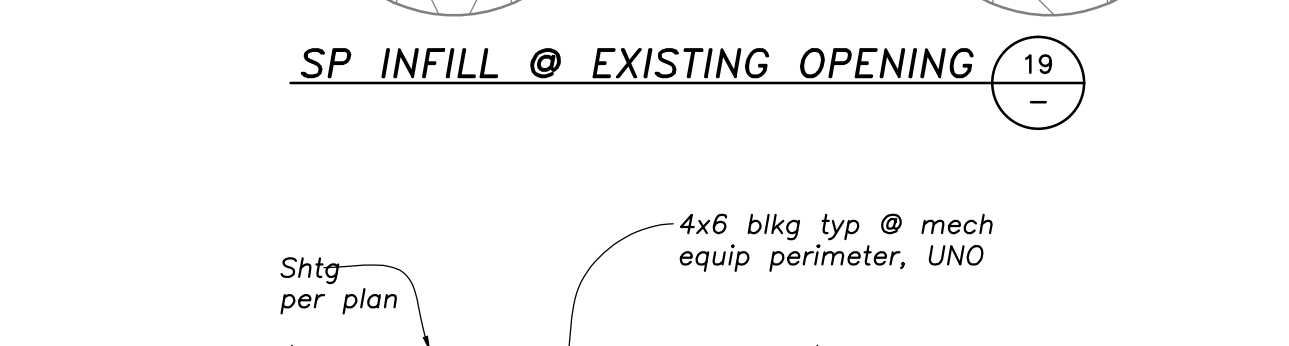

TYPICAL BLOCKING 20

JOIST HANGER SCHEDULE 21

Joist size	Hanger
2x4	LUS24
2x6	LUS26
2x10, 12, 14	LUS210
3x8	HUS8
3x10	HUS10
3x12	HUS12
4x4	LUS44
4x6	HUS46
4x8	HUS48
4x10	HUS410
4x12	HUS412
6x8	HUS68 MAX
6x10	HUS610 MAX
6x12	HUS612 MAX

Notes:
 1. Fill all holes in hanger with 2x8 nails. UNO Use nail size & type as specified in catalog.
 2. Use Simpson hangers, or approved equal.
 3. Where double joists occur, use similar "LUS", "HU", or "HUS" hanger.
 4. At angled connections, use skewed joist hangers conforming with table, typ UNO.

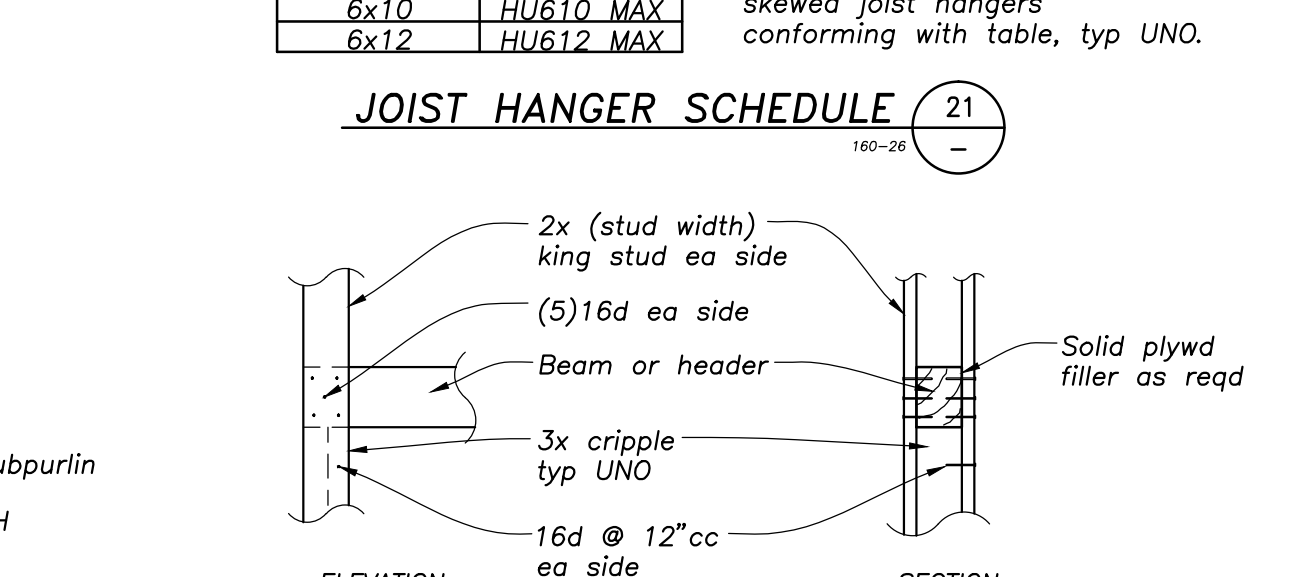

BEAM OR HEADER TO WALL 22

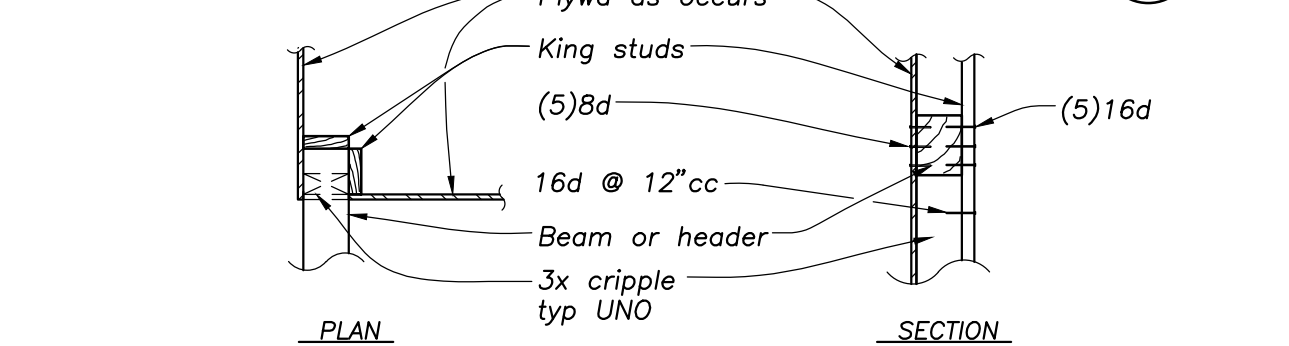

BEAM OR HEADER AT CORNER 23

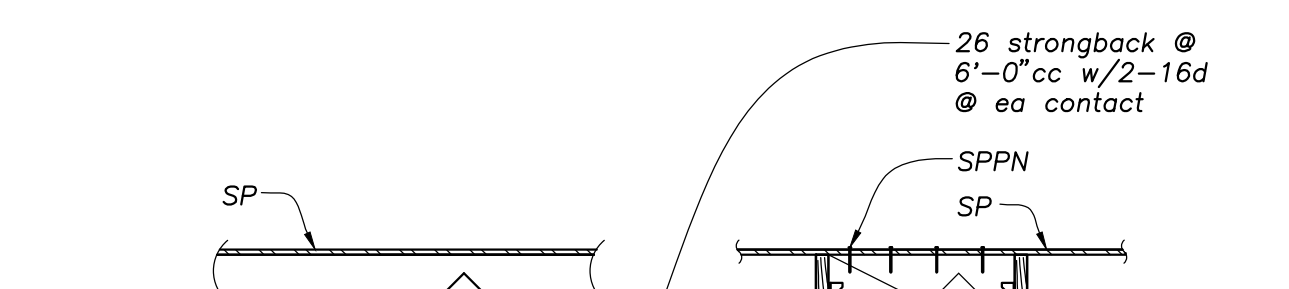

PARTIAL HEIGHT STUD WALL @ T-BAR CEILING 24

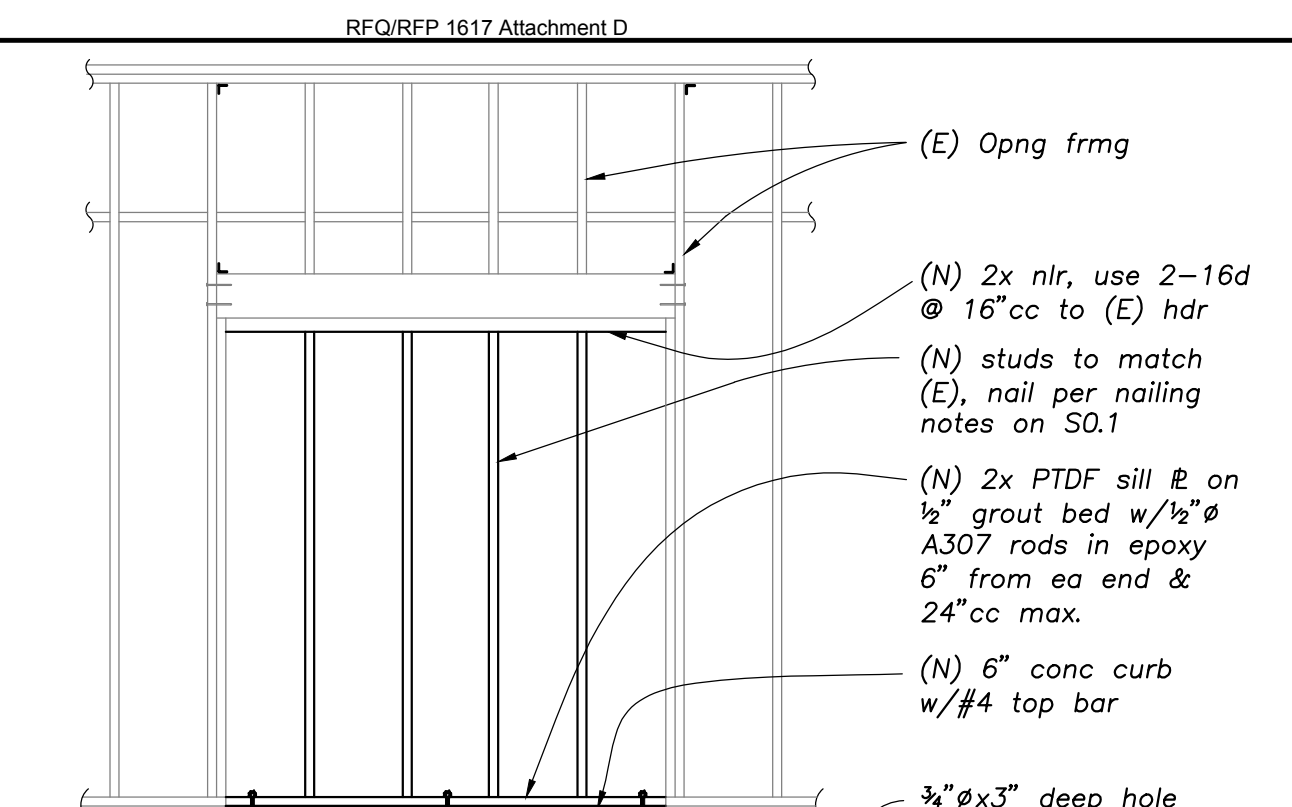

INFILL FRAMING - WITH CURB 12

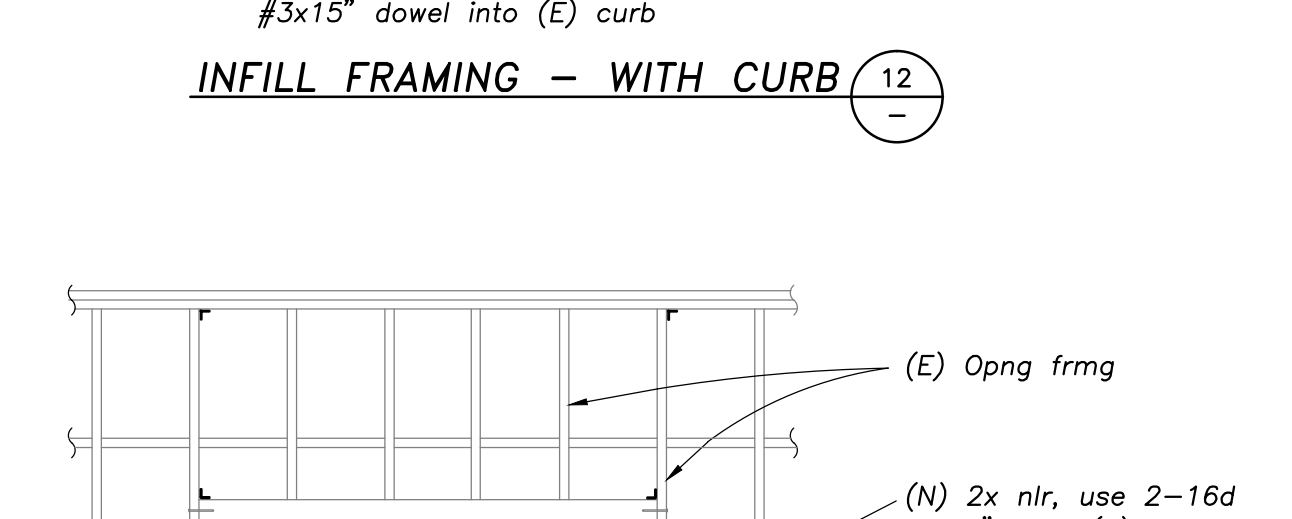

INFILL FRMG - WITH OUT CURB 13

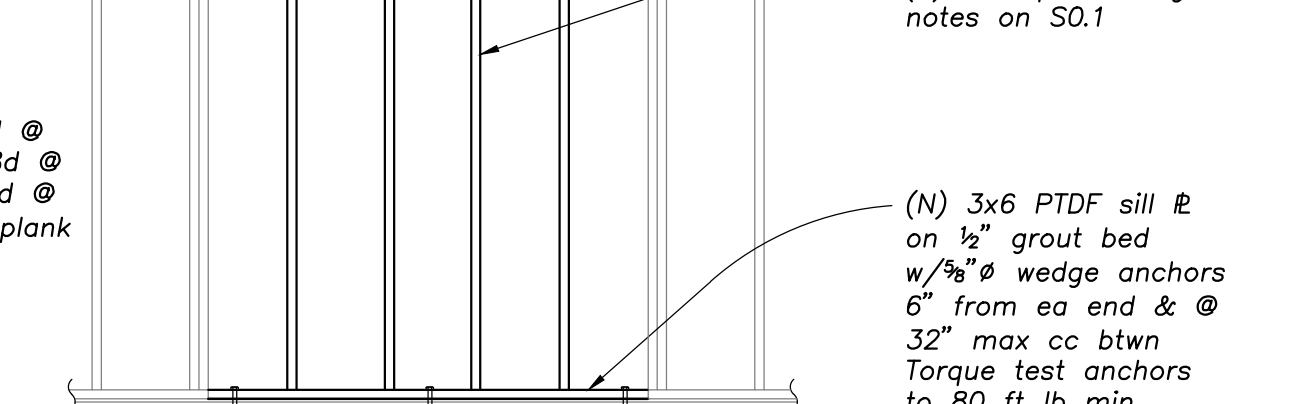

NEW FRAMED WALL OPENINGS 14

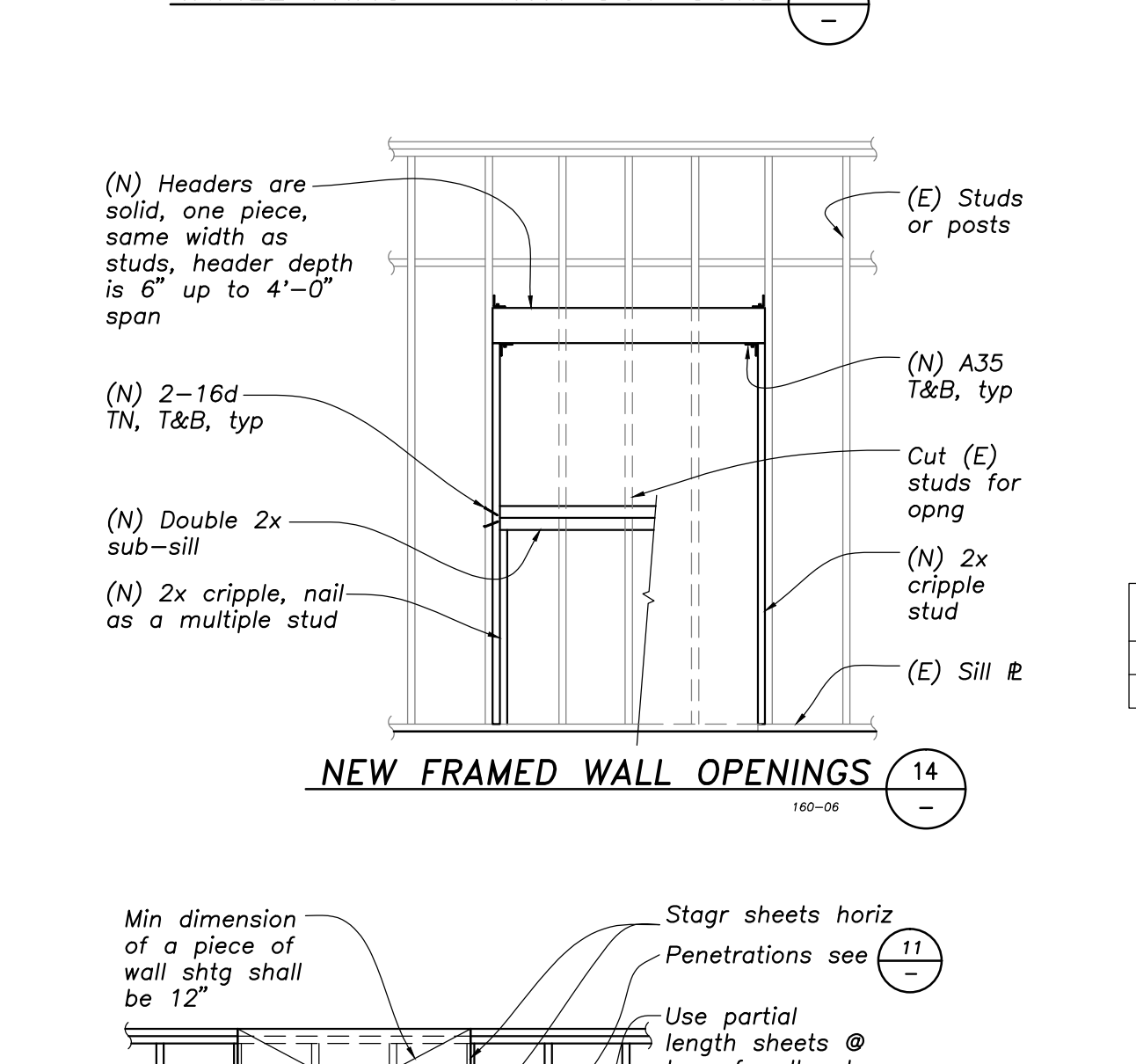

SP WALL SHEATHING 15

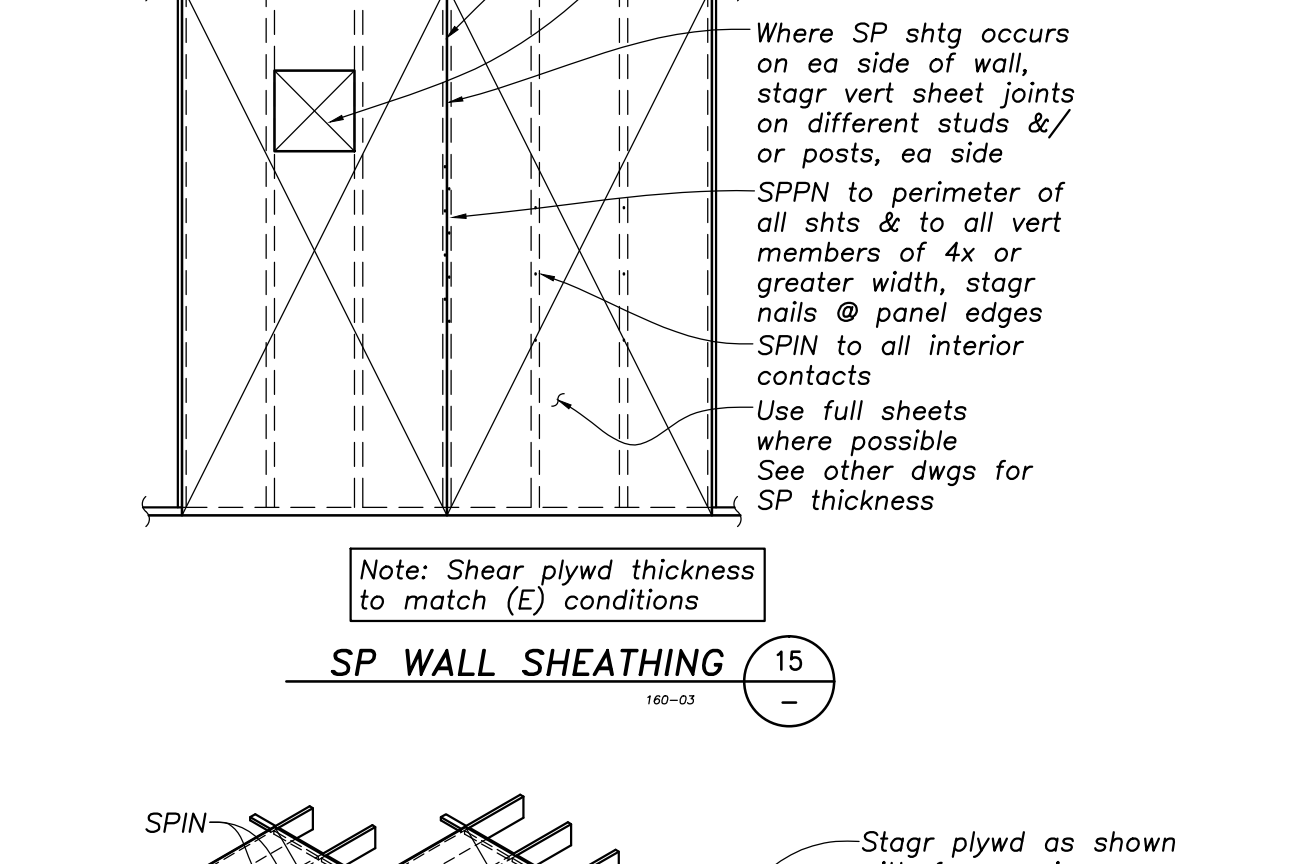

CONVENTIONAL ROOF SHEATHING LAYOUT 16

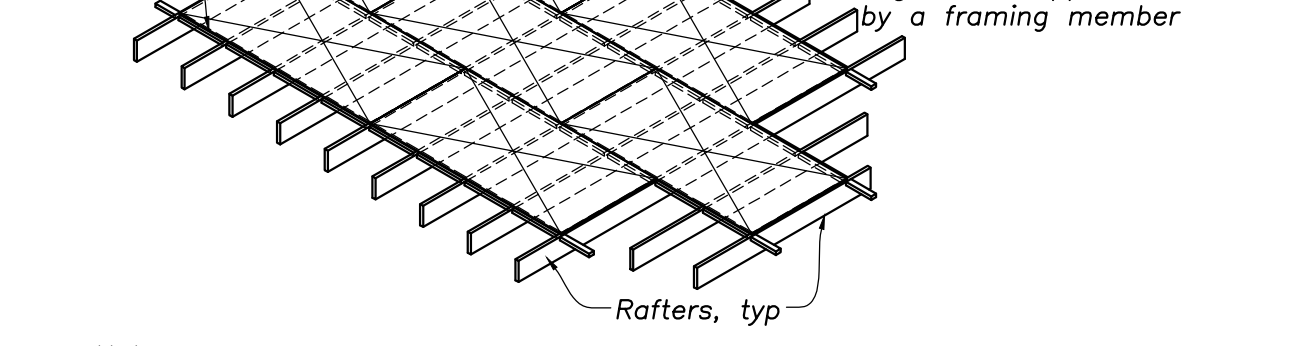

SHEAR WALL OPENING 11

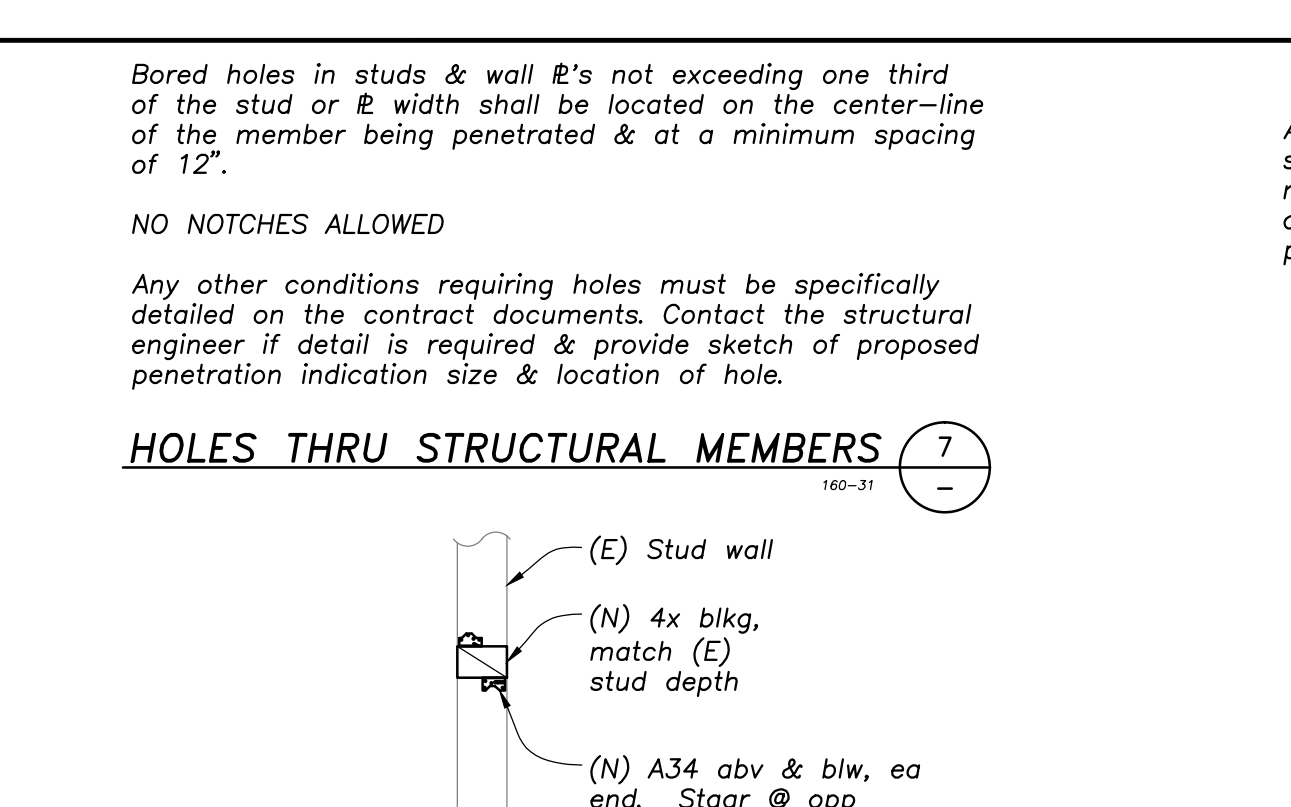

HOLES THRU STRUCTURAL MEMBERS 7

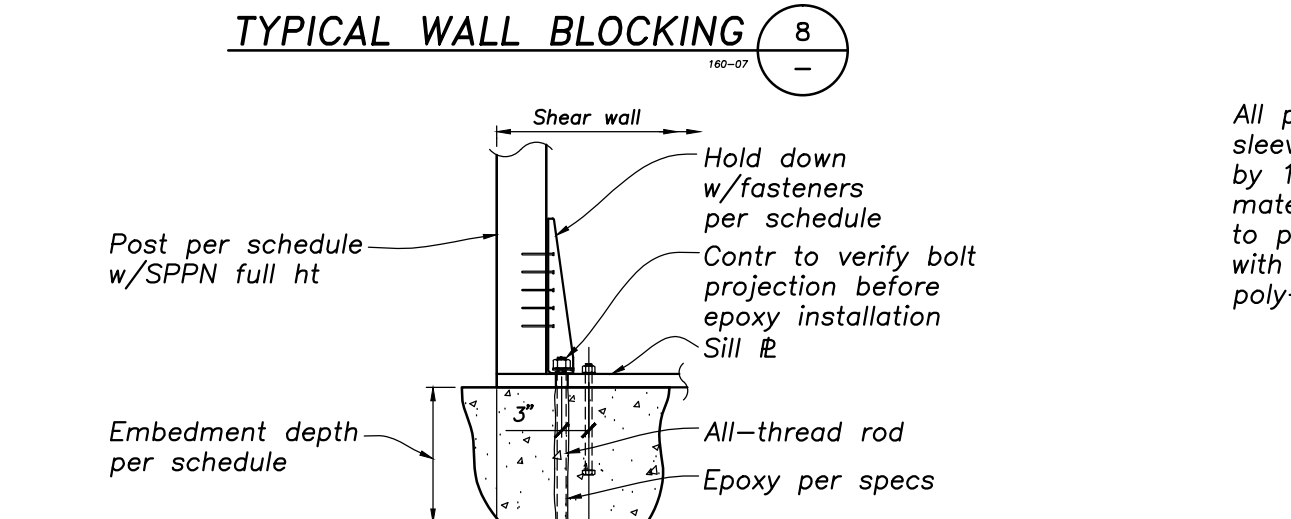

TYPICAL WALL BLOCKING 8

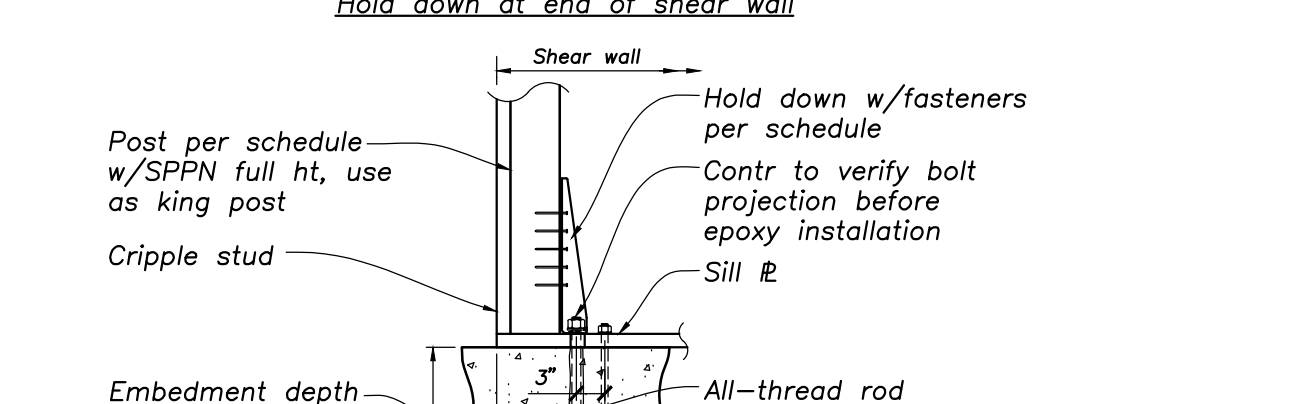

PIPE BELOW FOOTING 2

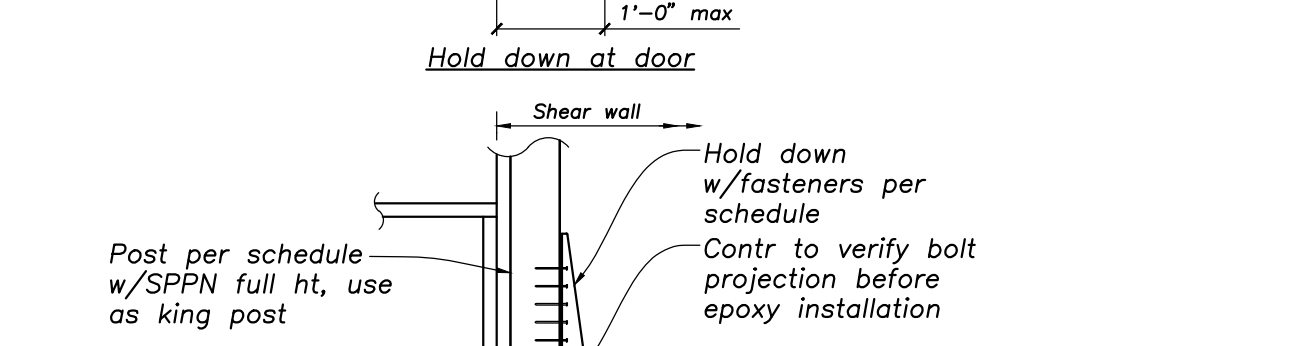

(N) SLAB @ (E) CONDITIONS 3

HOLDOWN (HD) 9

Simpson HD No.	Fastener (No. & Type)	Holddown (No.)	Min post reqd (match stud width)	Minimum Rod Embedment
HU2-SDS25	6-SDS"x2 1/2 SCR	4x	4x	12"
HU5-SDS25	14-SDS"x2 1/2 SCR	4x	4x	12"

NOTE:
 1. HD's do not substitute for sill bolts
 2. Install HD's per Simpson's catalog except above detailed anchor bolts as req.
 3. HD post may be used as king stud
 4. Rod embedment is from FT down, increase embedment at curbs as required to match

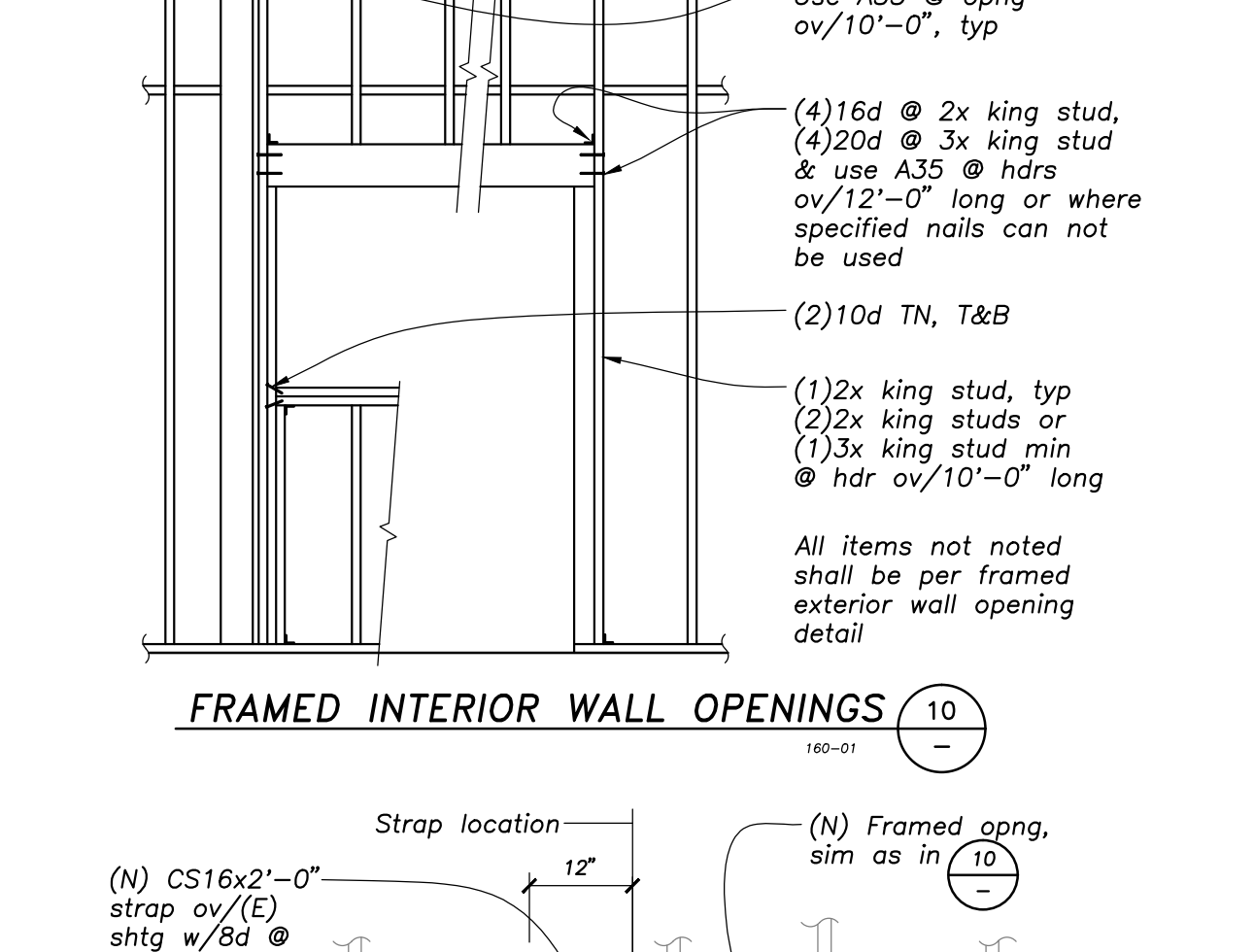

FRAMED INTERIOR WALL OPENINGS 10

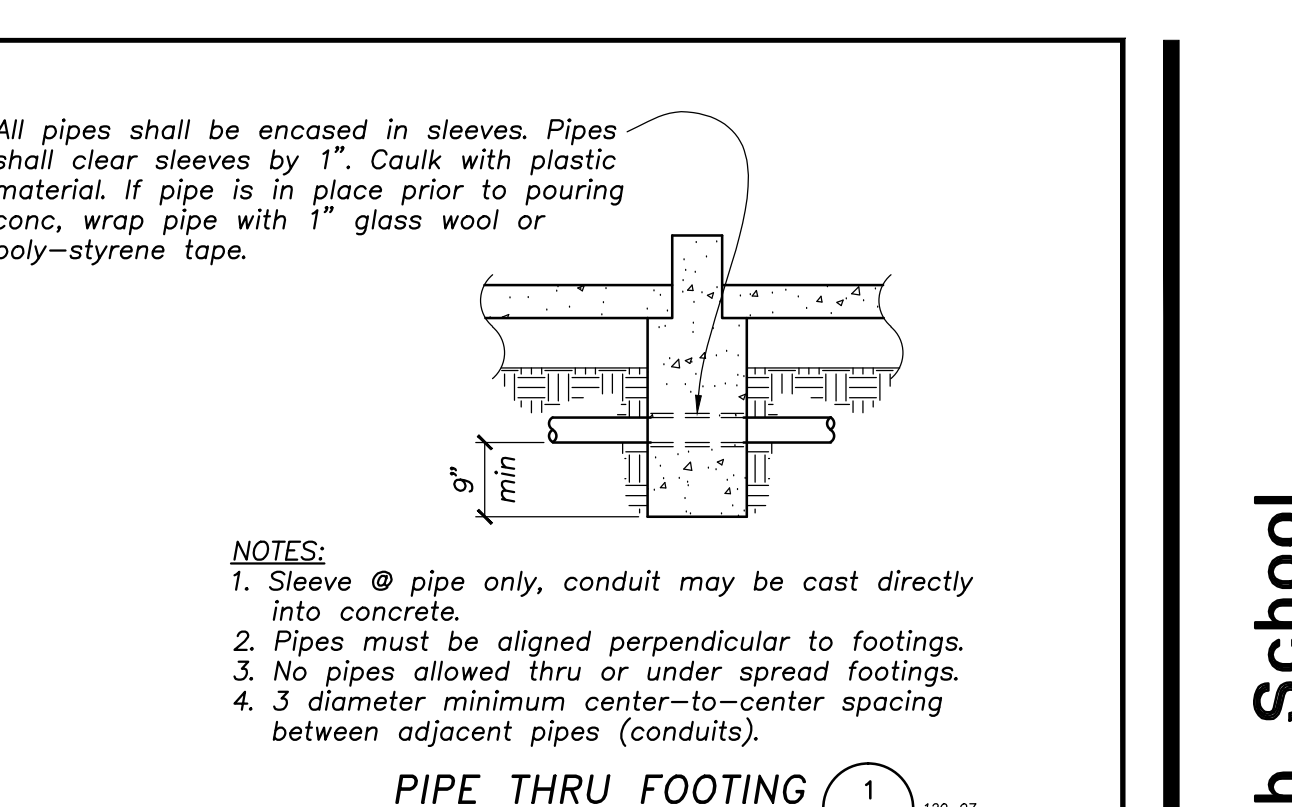

PIPE THRU FOOTING 1

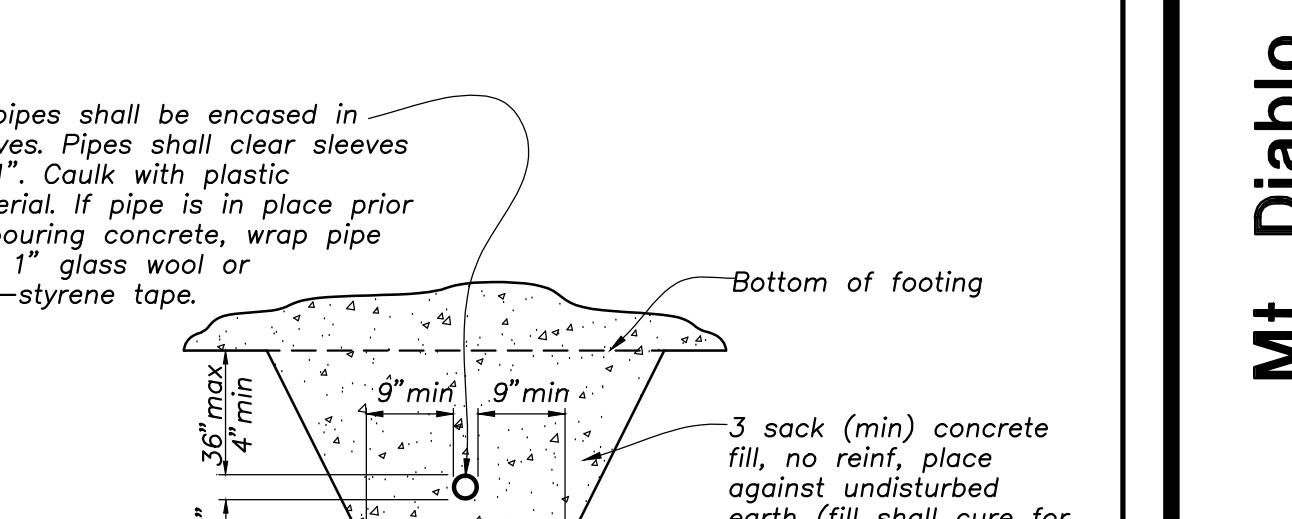

(N) SLAB @ (E) CONDITIONS 4

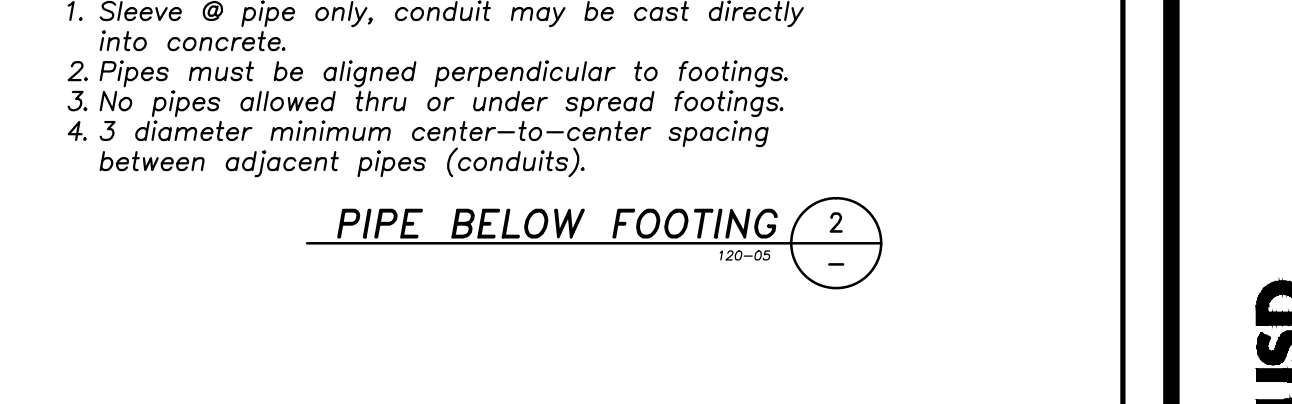

TYPICAL REBAR BENDS 5

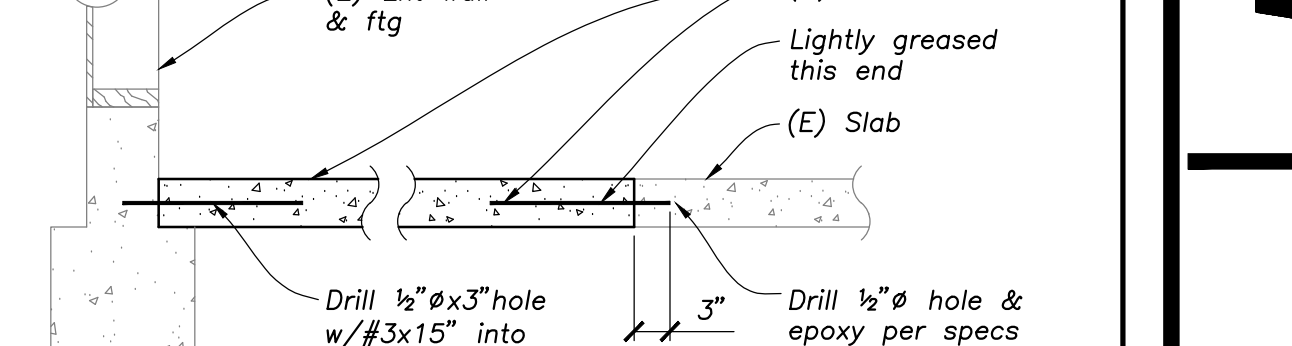

SILL PLATE PENETRATIONS 6

MDUSD MOUNTAIN DIABLO UNIFIED SCHOOL DISTRICT
 2450 Grant Street, Concord, California 94520

FILE NO. xx-xx
 IDENTIFICATION STAMP
 DIV. OF THE STATE ARCHITECT
 OFFICE OF REGULATION SERVICES
 APPLICATION NO. 01-FLS-88
 AC. DATE

DIVISION OF THE STATE ARCHITECT
 revision date: by:

BARRISH PELHAM & ASSOCIATES, INC.
 CONSULTING ENGINEERS
 (916) 418-9100
 Sacramento, CA
 barrish.com

REGISTERED STRUCTURAL ENGINEER
 No. 2558
 Exp. 03/21/14
 STATE OF CALIFORNIA

CONSULTANT

nacht&lewis
 600 Q Street, Suite 100
 Sacramento, CA 95811
 www.nachtandlewis.com
 916.329.4000

ARCHITECT

REVISIONS

NO.	DESCRIPTION	DATE	REV'D

DATE February 19, 2012
JOB NO. Y1211.00
SHEET TITLE Typical Details

SHEET NO. S0.2
SHEET OF TOTAL
DSA SUBMITTAL SET

ONE AND ONE-HALF INCH = ONE FOOT
ONE INCH = ONE FOOT
THREE-QUARTERS INCH = ONE FOOT
ONE-HALF INCH = ONE FOOT
ONE-QUARTER INCH = ONE FOOT
ONE-EIGHTH INCH = ONE FOOT
ONE-SIXTEENTH INCH = ONE FOOT
ONE INCH = TWENTY FEET

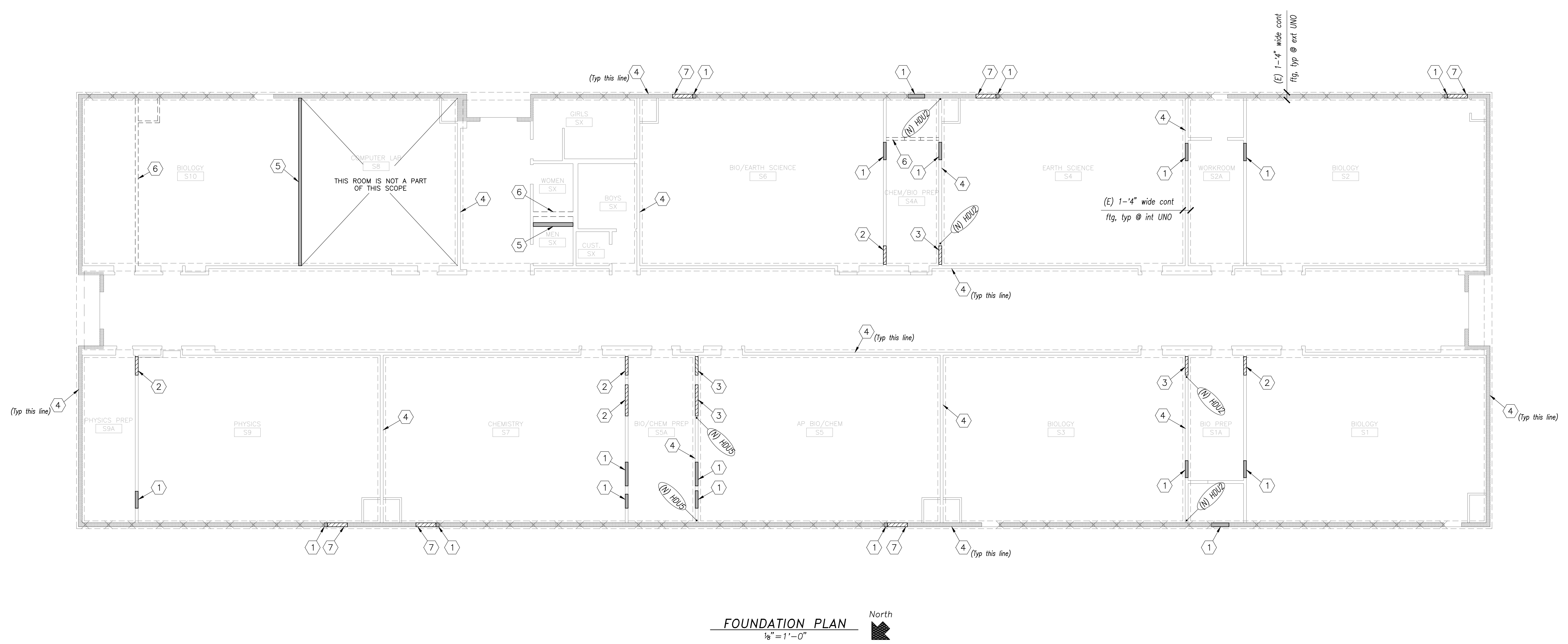

FOUNDATION PLAN
1/8" = 1'-0"

- SHEET NOTES**
- ① Infill (E) opng per 12 S0.2 and/or 13 S0.2
 - ② (N) Opng in non-structural stud wall per 14 S0.2
 - ③ (N) Opng in structural stud wall per 10 S0.2 & 11 S0.2
 - ④ (E) Stud wall w/1/2" SP w/8d @ 3"cc
 - ⑤ (N) Non-structural stud wall per 4 S0.2 & 29 S0.2
 - ⑥ Demo (E) non-structural wall
 - ⑦ Reframe (E) window opng for (N) door per 14 S0.2

- FOUNDATION PLAN LEGEND & NOTES**
- Indicates (E) structural stud wall on on 6" high curb on line footing
 - Indicates (E) structural stud wall on line footing
 - Indicates (E) non-structural stud wall
 - Indicates (E) non-structural stud wall to be demolished
 - Indicates (N) opng in (E) stud wall
 - Indicates (N) stud wall or stud wall infill
 - Indicates (E) post or mullion
 - Indicates Hold Down (HD) per 9/S.02 coordinate location with Arch dwgs

- Notes:**
1. Verify & coordinate all dimensions & elevations w/Arch dwgs.
 2. Verify & coordinate extent of demolition w/Arch, Mech & Elect dwgs.
 3. Existing stud walls are 2x6 @ 16"cc unless noted otherwise (UNO).
 4. All existing interior slabs are 5" thick w/#3 @ 12"cc each way, centered in slab.
 5. Exterior slabs are not shown on these plans.

MDUSD
Mt. Diablo High School
Building S - Science Lab Modernization

2450 Grant Street
Concord, California 94520

Mt. Diablo Unified School District

FILE NO. xx-xx
IDENTIFICATION STAMP
DIV. OF THE STATE ARCHITECT
OFFICE OF REGULATION SERVICES

APPLICATION NO.
01-
AC. FLS. SS
DATE

DIVISION OF THE STATE ARCHITECT
revision date: by:

B (916) 418-9100
Sacramento, CA
barrish.com

Barrish Pelham & Associates, Inc.
Consulting Engineers

REGISTERED STRUCTURAL ENGINEER
No. 2558
Exp. 03/21/14
STATE OF CALIFORNIA

CONSULTANT

nacht&lewis
600 Q Street, Suite 100
Sacramento, CA 95811
www.nachtlewis.com
916.329.4000

ARCHITECT

REVISIONS		
NO.	DESCRIPTION	DATE

DATE February 19, 2012
JOB NO. Y1211.00
SHEET TITLE
Foundation Plan
SHEET NO.
S2.1
SHEET ___ OF ___ TOTAL
DSA SUBMITTAL SET

ONE INCH = TWENTY FEET
 ONE-SIXTEENTH INCH = ONE FOOT
 ONE-EIGHTH INCH = ONE FOOT
 ONE-FOURTH INCH = ONE FOOT
 ONE-HALF INCH = ONE FOOT
 THREE-QUARTERS INCH = ONE FOOT
 ONE INCH = ONE FOOT
 ONE AND ONE-HALF INCH = ONE FOOT

DUCT LEGEND	
DOUBLE LINE SYMBOL	DESCRIPTION
	RECTANGULAR DUCT - WIDTH x DEPTH (PLAN VIEW) DEPTH x WIDTH (SECTION VIEW)
	ACOUSTICALLY LINED RECTANGULAR DUCT-DIMENSIONS ARE OUTSIDE
	ACOUSTICALLY LINED ROUND DUCT-DIMENSIONS ARE OUTSIDE
	MANUAL AIR DAMPER
	RISE OR DROP DUCT IN DIRECTION OF AIR FLOW
	RECTANGULAR TO RECTANGULAR TRANSITION , MAX. SLOPE OF 1:3
	RECTANGULAR TO ROUND TRANSITION , MAX. SLOPE OF 1:3
	ELBOW, RECTANGULAR, SMOOTH RADIUS, WITHOUT TURNING VANES
	SQUARE/RECTANGULAR DUCT ELBOW WITH TURNING VANES
	CONVERGING OR DIVERGING TEE, 45° ENTRY, RECTANGULAR MAIN AND BRANCH. WHEN REDUCING MAIN, SIDE OF TAKE OFF OR ENTRY BRANCH TO BE FLAT, OTHER SIDES MAX. SLOPE OF 1:3
	CONICAL DUCT TAKE OFF FROM RECTANGULAR VIA SPIN-IN W/DAMPER AND SCOOP
	ROUND DUCT TAKE OFF FROM RECTANGULAR VIA SMOOTH CONVERGING BELL MOUTH
	RECTANGULAR DUCT TEE MAD'S ON THE 2 BRANCHES, THROAT SIZED FOR EQUAL PRESSURE DROP
	RECTANGULAR DUCT SPLIT MAD'S, THROAT SIZED FOR EQUAL PRESSURE DROP
	3-WAY RECTANGULAR SPLIT WITH TWO TRANSITIONAL ELBOWS AND TRANSITIONING MAIN. DOWNSTREAM MAD'S ON THE TREE BRANCHES. THROATS SIZED FOR EQUAL PRESSURE DROP.
	FOR CONCEALED DUCT: DROP TO DIFFUSER SHALL BE FULL SIZE OF DIFFUSER NECK. FOR EXPOSED DUCT: DROP SHALL BE FULL SIZE OF OD DIFFUSER FRAME, FLANGE FOR MOUNTING DIFFUSER TURNED IN. AIR EXTRACTOR AND EQUALIZER GRID AT CONNECTION TO MAIN.
	SUPPLY AIR, SUPPLY AIR DUCT IN SECTION, SUPPLY DROP
	RETURN AIR, RETURN AND OUTSIDE AIR DUCT IN SECTION, RETURN AIR DROP
	EXHAUST AIR, EXHAUST AIR DUCT IN SECTION, EXHAUST AIR DROP
	FLEXIBLE DUCT (ROUND)
	FC FLEXIBLE CONNECTION

MECHANICAL LEGEND		
SYMBOL	ABBREVIATION	DESCRIPTION
	ABV	ABOVE
	ABC	ABOVE CEILING
	AFF	ABOVE FINISHED FLOOR
	AFG	ABOVE FINISHED GRADE
	AD , AP	ACCESS DOOR , ACCESS PANEL
	AC	AIR CONDITIONING
	BDD	BACK DRAFT DAMPER
	BF	BELOW FLOOR
	BHP	BRAKE HORSE POWER
	BTU(H)	BRITISH THERMAL UNITS (PER HOUR)
	CC	CENTER TO CENTER
	CLG	CEILING
	CEF	CEILING EXHAUST FAN
	CLR	CLEAR
	CONC	CONCRETE
	CONN	CONNECT OR CONNECTION
	CONT	CONTINUATION
	CONTR	CONTRACTOR
	CFM	CUBIC FEET OF AIR FLOW PER MINUTE
	DPR	DAMPER
	°F	DEGREES FAHRENHEIT
	DIA	DIAMETER , PHASE
	DL	DOOR LOUVER
	DN	DOWN
	DB	DRY BULB (DEGREES FAHRENHEIT)
	EP	ELECTRICAL PANEL
	EL	ELEVATION
	ENT	ENTERING
	EDB	ENTERING DRY BULB
	EW	ENTERING WATER
	EWT	ENTERING WATER TEMPERATURE
	EWB	ENTERING WET BULB
	EA	EXHAUST AIR
	EF	EXHAUST FAN
	(E), EXIST	EXISTING
	(E)	EXISTING TO BE REMOVED
	(E)	EXISTING TO BE ABANDONED IN PLACE
	ESP	EXTERNAL STATIC PRESSURE
	FIN	FINISH
	FLR	FLOOR
	FLA	FULL LOAD AMPS
		EXPANSION JOINT
	GPH	GALLONS PER HOUR
	GPM	GALLONS PER MINUTE
	GV	GATE VALVE
	GALV	GALVANIZED
	GI	GALVANIZED IRON
	GA	GAUGE
	HW	HOT WATER
	HTG	HEATING
	IH	INTAKE HOOD (OUTSIDE AIR)
	KW	KILOWATTS

MECHANICAL LEGEND cont'd		
SYMBOL	ABBREVIATION	DESCRIPTION
	KWH	KILOWATT HOUR
	LDB	LEAVING DRY BULB IN DEGREES FAHRENHEIT
	LWB	LEAVING WET BULB IN DEGREES FAHRENHEIT
	LRA	LOCKED ROTOR AMPERES
	LVR	LOUVER
	MAD, MD	MANUAL AIR DAMPER
	MFR	MANUFACTURER
	MAX	MAXIMUM
	MIN	MINIMUM
	(N)	NEW
	OC	ON CENTER
	OA	OUTSIDE AIR
	OD	OUTSIDE DIAMETER
	OH	OVERHEAD
		PIPE DROP
		PIPE RISE
	POC	POINT OF CONNECTION
	POD	POINT OF DISCONNECT
	RS	REFRIGERANT SUCTION PIPING
	RL	REFRIGERANT LIQUID PIPING
	RA	RETURN AIR
	RPM	REVOLUTIONS PER MINUTE
	RLA	RUNNING LOAD AMPERES
	REFRIG.	REFRIGERANT PIPING
	RV.	RELIEF VENT
	SB	SECURITY BARS
	SM	SHEET METAL
	SD	SMOKE DAMPER
	SKD	SMOKE DETECTOR
	SD	SPLITTER DAMPER
	SP	STATIC PRESSURE
	SPD	STATIC PRESSURE DROP
	SA	SUPPLY AIR
	SOV	SHUT-OFF VALVE (GAS)
	TCP	TEMPERATURE CONTROL PANEL
	T	THERMOSTAT, "X" INDICATES DEVICE CONTROLLED MOUNT @ +48" AFF.
	MBH	THOUSAND BRITISH THERMAL UNITS PER HOUR
	TA	TO ABOVE
	TB	TO BELOW
	TP	TOTAL PRESSURE
	TSP	TOTAL STATIC PRESSURE
	TYP	TYPICAL
	UG	UNDERGROUND
	UCD	UNDER CUT DOOR
	UON	UNLESS OTHERWISE NOTED
	W	WATTS
	WT	WEIGHT
	WB	WET BULB
	WMS	WIRE MESH SCREEN

MEP COMPONENT ANCHORAGE NOTE

ALL MECHANICAL, PLUMBING, AND ELECTRICAL COMPONENTS SHALL BE ANCHORED AND INSTALLED PER THE DETAILS ON THE DSA APPROVED CONSTRUCTION DOCUMENTS. WHERE NO DETAIL IS INDICATED, THE FOLLOWING COMPONENTS SHALL BE ANCHORED OR BRACED TO MEET THE FORCE AND DISPLACEMENT REQUIREMENTS PRESCRIBED IN THE 2010 CBC, SECTIONS 1615A.1.12 THROUGH 1615A.1.22 AND ASCE 7-05 CHAPTER 6 AND 13.

- ALL PERMANENT EQUIPMENT AND COMPONENTS.
- TEMPORARY OR MOVABLE EQUIPMENT THAT IS PERMANENTLY ATTACHED (e.g. HARD WIRED) TO THE BUILDING UTILITY SERVICES SUCH AS ELECTRICITY, GAS OR WATER.
- MOVABLE EQUIPMENT WHICH IS STATIONED IN ONE PLACE FOR MORE THAN 8 HOURS AND HEAVIER THAN 400 POUNDS ARE REQUIRED TO BE ANCHORED WITH TEMPORARY ATTACHMENTS.

THE ATTACHMENT OF THE FOLLOWING MECHANICAL AND ELECTRICAL COMPONENTS SHALL BE POSITIVELY ATTACHED TO THE STRUCTURE, BUT NEED NOT BE DETAILED ON THE PLANS. THESE COMPONENTS SHALL HAVE FLEXIBLE CONNECTIONS PROVIDED BETWEEN THE COMPONENT AND ASSOCIATED DUCTWORK, PIPING, AND CONDUIT.

- COMPONENTS WEIGHING LESS THAN 400 POUNDS AND HAVE A CENTER OF MASS LOCATED 4 FEET OR LESS ABOVE THE ADJACENT FLOOR OR ROOF LEVEL THAT DIRECTLY SUPPORT THE COMPONENT.
- COMPONENTS WEIGHING LESS THAN 20 POUNDS, OR IN THE CASE OF DISTRIBUTION SYSTEMS, LESS THAN 5 POUNDS PER FOOT, WHICH ARE SUSPENDED FROM A ROOF OR FLOOR OR HUNG FROM A WALL.

FOR THOSE ELEMENTS THAT DO NOT REQUIRE DETAILS ON THE APPROVED DRAWINGS, THE INSTALLATION SHALL BE SUBJECT TO THE APPROVAL OF THE STRUCTURAL ENGINEER OF RECORD AND THE DSA DISTRICT STRUCTURAL ENGINEER. THE PROJECT INSPECTOR WILL VERIFY THAT ALL COMPONENTS AND EQUIPMENT HAVE BEEN ANCHORED IN ACCORDANCE WITH ABOVE REQUIREMENTS.

PIPING, DUCTWORK & ELECTRICAL DISTRIBUTION SYSTEM BRACING NOTE

PIPING, DUCTWORK, AND ELECTRICAL DISTRIBUTION SYSTEMS SHALL BE BRACED TO COMPLY WITH THE FORCES AND DISPLACEMENTS PRESCRIBED IN ASCE 7-05 SECTION 13.3 AS DEFINED IN ASCE 7-05 SECTION 13.6.8, 13.6.7, 13.6.5.6, AND 2010 CBC, SECTIONS 1615A.1.20, 1615A.1.21 AND 1615A.1.22.

THE BRACING AND ATTACHMENTS TO THE STRUCTURE SHALL BE DETAILED ON THE APPROVED DRAWINGS OR THEY SHALL COMPLY WITH ONE OF THE OSHPD PRE-APPROVALS (OPA #) AS MODIFIED TO SATISFY ANCHORAGE REQUIREMENTS OF ACI 318, APPENDIX D.

COPIES OF THE MANUAL SHALL BE AVAILABLE ON THE JOBSITE PRIOR TO THE START OF HANGING THE BRACING OF THE PIPE, DUCTWORK, AND ELECTRICAL DISTRIBUTION SYSTEMS.

THE STRUCTURAL ENGINEER OF RECORD SHALL VERIFY THE ADEQUACY OF THE STRUCTURE TO SUPPORT THE HANGER AND BRACE LOADS.

MECHANICAL GENERAL NOTES

- REFER TO ARCHITECTURAL SHEET A001 THRU A005 FOR TYPICAL INSTALLATION DETAILS AND NOTES FOR TEAM AIR ENCLOSURES, INTAKE LOUVERS, MECHANICAL ROOF SCREEN AND CONDENSOR ENCLOSURE DETAILS.
- REFER TO STRUCTURAL SHEET S001 GG FOR TYPICAL DETAILS FOR MECHANICAL SCREENS, ROOF AND WALL OPENINGS AND OTHER RELATED FRAMING DETAILS AND INFORMATION.
- REFER TO ELECTRICAL DRAWINGS FOR LIGHTING RELOCATION FOR NEW FURNACE ENCLOSURES.
- PATCH ALL WALL, FLOOR, AND ROOF OPENINGS WITH APPROPRIATE BLOCKING TO MATCH SURROUNDING SURFACES PER STRUCTURAL/ ARCHITECTURAL PLANS AND SPECIFICATIONS.

MDUSD
 Mt. Diablo High School
 Building S - Science Lab Modernization
 2450 Grant Street
 Concord, California 94520

MDUSD
 REGISTERED PROFESSIONAL ENGINEER
 # 22836
 EXPIRES 9/30/14
 MECHANICAL
 STATE OF CALIFORNIA

DATE SIGNED: _____

CAPITAL ENGINEERING CONSULTANTS, INC.
 RANCHO CORDOVA, CALIFORNIA
 CS/SRL 12/02/00
 PM - DESIGN TEAM PROJECT NO. _____

nacht&lewis
 800 G Street, Suite 100
 Sacramento, CA 95811
 www.nachtandlewis.com
 916.329.4000

FILE NO. xx-xx
 IDENTIFICATION STAMP
 DIV. OF THE STATE ARCHITECT
 OFFICE OF REGULATION SERVICES

APPLICATION NO. 01-
 AC. FLS. 88
 DATE _____

DIVISION OF THE STATE ARCHITECT
 revision date: _____ by: _____

REGISTERED PROFESSIONAL ENGINEER
 # 22836
 EXPIRES 9/30/14
 MECHANICAL
 STATE OF CALIFORNIA

DATE SIGNED: _____

CAPITAL ENGINEERING CONSULTANTS, INC.
 RANCHO CORDOVA, CALIFORNIA
 CS/SRL 12/02/00
 PM - DESIGN TEAM PROJECT NO. _____

CONSULTANT

nacht&lewis
 800 G Street, Suite 100
 Sacramento, CA 95811
 www.nachtandlewis.com
 916.329.4000

ARCHITECT

REVISIONS			
NO.	DESCRIPTION	DATE	REV'D

DATE February 19, 2013
 JOB NO. Y1211.00
 SHEET TITLE

HVAC Legend & Notes

SHEET NO.
MO.1
 SHEET ___ OF ___ TOTAL
 DSA SUBMITTAL SET

ONE INCH = TWENTY FEET
 ONE-SIXTEENTH INCH = ONE FOOT
 ONE-EIGHTH INCH = ONE FOOT
 ONE-FOURTH INCH = ONE FOOT
 ONE-HALF INCH = ONE FOOT
 THREE-QUARTERS INCH = ONE FOOT
 ONE INCH = ONE FOOT
 ONE AND ONE-HALF INCH = ONE FOOT

EXHAUST HOOD SCHEDULE

UNIT	AREA SERVED	GREENHECK MODEL NO.	TYPE	TOTAL THROAT SIZE	CFM	S.P. (IN. W.G.)	OPER. WT. (LBS.)	MOUNTING DETAIL
EH 1	PHYSICS PREP S9A	GRS-12	EXHAUST	12 1/4"ø	400	0.04	30	1 M5.1
EH 2	BIOLOGY S10	GRS-12	EXHAUST	12 1/4"ø	400	.04	30	1 M5.1
EH 3	WORK RM. S2A	GRS-12	EXHAUST	12 1/4"ø	400	.04	30	1 M5.1
EH 4	VESTIBULE S2B	GRS-8	EXHAUST	8 1/4"ø	150	.04	25	1 M5.1

NOTES:
 1. PROVIDE WITH MANUFACTURER'S 14" HIGH ROOF CURB.
 2. FACTORY BIRD SCREEN AT OULET OPENINGS.

DIFFUSER, REGISTER & GRILLE SCHEDULE

SYMBOL	DESCRIPTION	TITUS	NAILOR	METALAIR	KRUEGER
SR-1	DIRECT SPIRAL DUCT-MOUNTED SUPPLY 3/4" BLADE SPACING VERTICAL FRONT BLADES RADIUS END CAPS TO MATCH DUCT WITH AIR SCOOP DAMPER/EXTRACTOR.	U300FL	--	--	--
E & TG	EXHAUST OR TRANSFER GRILLE WITH 30" OR 45" HORIZONTAL BARS, & 3/4" SPACING NO SUBSTITUTIONS ALLOWED.	25 RL	7145 H	--	--

NOTES:
 1. FURNISH ALL PRODUCTS OF A SINGLE MANUFACTURER.
 2. COORDINATE DIFFUSER TYPE WITH REFLECTED CEILING PLAN.
 3. OPPOSED BLADE DAMPERS ARE NOT REQUIRED AT REGISTERS OR GRILLES UNLESS NOTED OTHERWISE.
 4. PROVIDE MANUAL AIR DAMPERS AT EACH BRANCH DUCT TO A SINGLE DIFFUSER, REGISTER OR GRILLE.

FAN SCHEDULE

UNIT	AREA SERVED	"GREENHECK" MODEL NO.	CFM	SP (IN. W.G.)	DUTY	STYLE	RPM	HP WATTS	VOLT/PH	OPER. WT. (LBS.)	MOUNTING DETAIL	CONTROL DIAGRAM	NOTES
REF 1	PHYSICS S9	CUE-099-A	1000	.25	E	RE	1531	1/4	220V/ 1 PH	75	5 M5.1	7 M5.1	1,2,3,4,5
REF 2	CHEMISTRY S7	CUE-099-A	1000	.25	E	RE	1531	1/4	220V/ 1 PH	75	5 M5.1	7 M5.1	1,2,3,4,5
REF 3	BIO/CHEM PREP S5A	CUE-099-A	1000	0.375	E	RE	1173	1/4	220V/ 1 PH	75	5 M5.1	6 M5.1	1,2,3,4,7
REF 4	AP/BIO CHEM S5	CUE-099-A	1000	.25	E	RE	1531	1/4	220V/ 1 PH	75	5 M5.1	7 M5.1	1,2,3,4,5
REF 5	BIOLOGY S3	CUE-099-A	1000	.25	E	RE	1531	1/4	220V/ 1 PH	75	5 M5.1	7 M5.1	1,2,3,4,5
REF 6	BIO/PREP S1A	CUE-099-A	1000	0.375	E	RE	1173	1/4	220V/ 1 PH	75	5 M5.1	6 M5.1	1,2,3,4,7
REF 7	BIOLOGY S1	CUE-099-A	1000	.25	E	RE	1531	1/4	220V/ 1 PH	75	5 M5.1	7 M5.1	1,2,3,4,5
REF 8	BIOLOGY S2	CUE-099-A	1000	.25	E	RE	1531	1/4	220V/ 1 PH	75	5 M5.1	7 M5.1	1,2,3,4,5
REF 9	EARTH SCIENCE S4	CUE-099-A	1000	.25	E	RE	1531	1/4	220V/ 1 PH	75	5 M5.1	7 M5.1	1,2,3,4,5
REF 10	CHEM/BIO PREP S4A	CUE-099-A	1000	0.375	E	RE	1173	1/4	220V/ 1 PH	75	5 M5.1	6 M5.1	1,2,3,4,7
REF 11	BIO/EARTH SCIENCE S6	CUE-099-A	1000	.25	E	RE	1531	1/4	220V/ 1 PH	75	5 M5.1	7 M5.1	1,2,3,4,5
REF 12	BIOLOGY S10	CUE-099-A	1000	.25	E	RE	1531	1/4	220V/ 1 PH	75	5 M5.1	7 M5.1	1,2,3,4,5
REF 13	BIO/CHEM PREP S5A	CUE-090-D	400	0.5	E	RE	1456	1/15	220V/ 1 PH	75	5 M5.1	6 M5.1	1,2,3,4,6
CEF 1	PHYSICS PREP S9A	SP-A510	400	.25	E	CE	1001	(224)	220V/ 1 PH	32	4 M5.1	6 M5.1	2,3 & 7
CEF 2	BIOLOGY S10	SP-A510	400	.25	E	CE	1001	(224)	220V/ 1 PH	32	4 M5.1	7 M5.1	2,3 & 5
CEF 3	WORK RM. S2A	SP-A510	400	.25	E	CE	1001	(224)	220V/ 1 PH	32	4 M5.1	7 M5.1	2,3 & 5
CEF 4	VESTIBULE S2B	SP-B150	150	.25	E	CE	1024	(129)	220V/ 1 PH	11	4 M5.1	7 M5.1	2,3 & 5
EF 1	BIO/CHEM PREP S5A	VEKTOR-H-9	700	0.5	E	RE	2347	3/4	220V/ 1 PH	274	2 M5.1	10 M5.1	1,2,3 & 6
EF 1	BIO/CHEM PREP S5A	VEKTOR-H-9	700	0.5	E	RE	2453	3/4	220V/ 1 PH	274	2 M5.1	10 M5.1	1,2,3 & 6

LEGEND
 DUTY: S-SUPPLY, R-RETURN, E-EXHAUST
 STYLE: BI-BACKWARD INCLINED, FC-FORWARD CURVED, RE-ROOF EXHAUST, CE-CEILING
 NOTES:
 1. INSTALL ON MANUFACTURER'S FACTORY ROOF CURB.
 2. PROVIDE WITH BACKDRAFT DAMPER.
 3. PROVIDE WITH THERMAL OVERLOAD PROTECTION.
 4. PROVIDE FACTORY CORROSION COATING FOR ALL FAN COMPONENTS EXPOSED TO AIR STEAM.
 5. PROVIDE WITH SPEED CONTROLLER AND WALL MOUNTED SPEED SWITCH AND 0-120 MIN. TWIST TIMER ON WALL WHERE SHOWN.
 6. CONTROL FROM SWITCH ON WALL.
 7. PROVIDE WITH SPEED CONTROLLER (FOR BALANCING ONLY) AND 0-120 MIN. TWIST TIMER ON WALL WHERE SHOWN FOR ON/OFF OPERATION.

INTAKE HOOD SCHEDULE

UNIT	AREA SERVED	"GREENHECK" MODEL NO.	TYPE	TOTAL THROAT SIZE	CFM	S.P. (IN. W.G.)	OPER. WT. (LBS.)	MOUNTING DETAIL	INTERLOCK WITH
IH 1	BIO-CHEM PREP S5A	FGI	INTAKE	36x20	3400	.09	145	1 M5.1	EF-1, EF-2 & REF-3
IH 2	BIO-CHEM PREP S4A	FGI	INTAKE	16x16	1000	.04	65	1 M5.1	REF-10
IH 3	WORK RM. S2A	FGI	INTAKE	14x14	600	.04	65	1 M5.1	CEF-3
IH 4	BIO-PREP S1A	FGI	INTAKE	16x16	1000	.04	65	1 M5.1	REF-6
IH 5	PHYSICS PREP S9A	FGI	INTAKE	14x14	600	.04	65	1 M5.1	CEF-1

NOTES:
 1. PROVIDE WITH 14" HIGH MANUFACTURER'S ROOF CURB.
 2. MOTORIZED DAMPER INTERLOCKED WITH FAN AS INDICATED ABOVE..
 3. FACTORY FILTER AT INLET OPENINGS.

MISC. EQUIPMENT SCHEDULE

UNIT	DESCRIPTION
FH 1	FUME HOOD "FISHER HAMILTON" SAFEAIRE 54L2825P0-P-S-B, 60" WIDE x 31 1/4" DEEP. PASS THROUGH DESIGN WITH DOUBLE SASH ON BOTH SIDES. PROVIDE WITH FUSIBLE LINK ON SASH FOR SIDE THRU RATED WALL. TUBE FLOURESCENT LIGHT FIXTURE, LIGHT SWITCH AND TWO DUPLEX RECEPTACLES, CW AND AND NATURAL GAS OUTLETS, CUP SINK, POLY RESIN LINER, RIGHT AND LEFT SIDES FINISHED. FACTORY SHROUD FROM TOP TO CEILING AND BOTH SIDES. 700 CFM AT 100 FPM, (0.09" SP) AND 18" OPENING. OPER. WEIGHT = 640 LBS. FOR MOUNTING SEE DETAIL: 3 FOR CONTROL DIAGRAM SEE DETAIL: 10
FH 2	FUME HOOD "FISHER HAMILTON" MODEL 554S8B10 CANOPY HOOD. 36" WIDE x 36" DEEP. 12"ø DUCT COLLAR. INTERNAL Baffles, STEEL CONSTRUCTION WITH REAGENT-RESISTANT FINISH. (4) 48" HANGER RODS. OPER. WEIGHT = 95 LBS. FOR MOUNTING SEE DETAIL: 11 FOR CONTROL DIAGRAM SEE DETAIL: 10

Mt. Diablo High School
Building S - Science Lab Modernization

2450 Grant Street
 Concord, California 94520

Mt. Diablo Unified School District

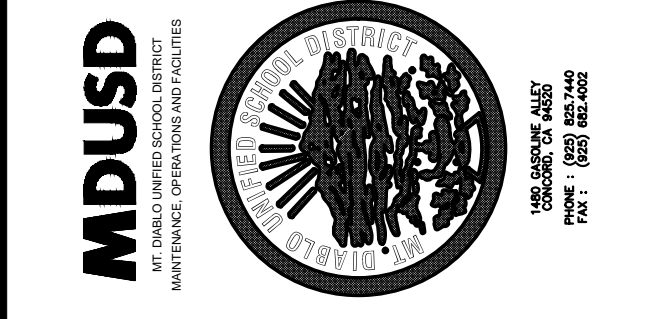

FILE NO. xx-xx
 IDENTIFICATION STAMP
 DIV. OF THE STATE ARCHITECT
 OFFICE OF REGULATION SERVICES
 APPLICATION NO. 01-
 AC. FLS. 88
 DATE

DIVISION OF THE STATE ARCHITECT
 revision date: by:



DATE SIGNED: _____
CAPITAL ENGINEERING CONSULTANTS, INC.
 RANCHO CORDOVA, CALIFORNIA
 CS/SL PM - DESIGN TEAM 12002.00 PROJECT NO.

CONSULTANT

nacht&lewis
 600 Q Street, Suite 100
 Sacramento, CA 95811
 www.nachtandlewis.com
 916.329.4000

ARCHITECT

REVISIONS

NO.	DESCRIPTION	DATE	REV'D

DATE February 19, 2013
 JOB NO. Y1211.00
 SHEET TITLE

HVAC Equipment Schedules

SHEET NO.
MO.2
 SHEET ___ OF ___ TOTAL
 DSA SUBMITTAL SET

ONE AND ONE-HALF INCH = ONE FOOT
 ONE INCH = ONE FOOT
 THREE-QUARTERS INCH = ONE FOOT
 ONE-HALF INCH = ONE FOOT
 ONE-QUARTER INCH = ONE FOOT
 ONE-EIGHTH INCH = ONE FOOT
 ONE-SIXTEENTH INCH = ONE FOOT
 ONE INCH = TWENTY FEET

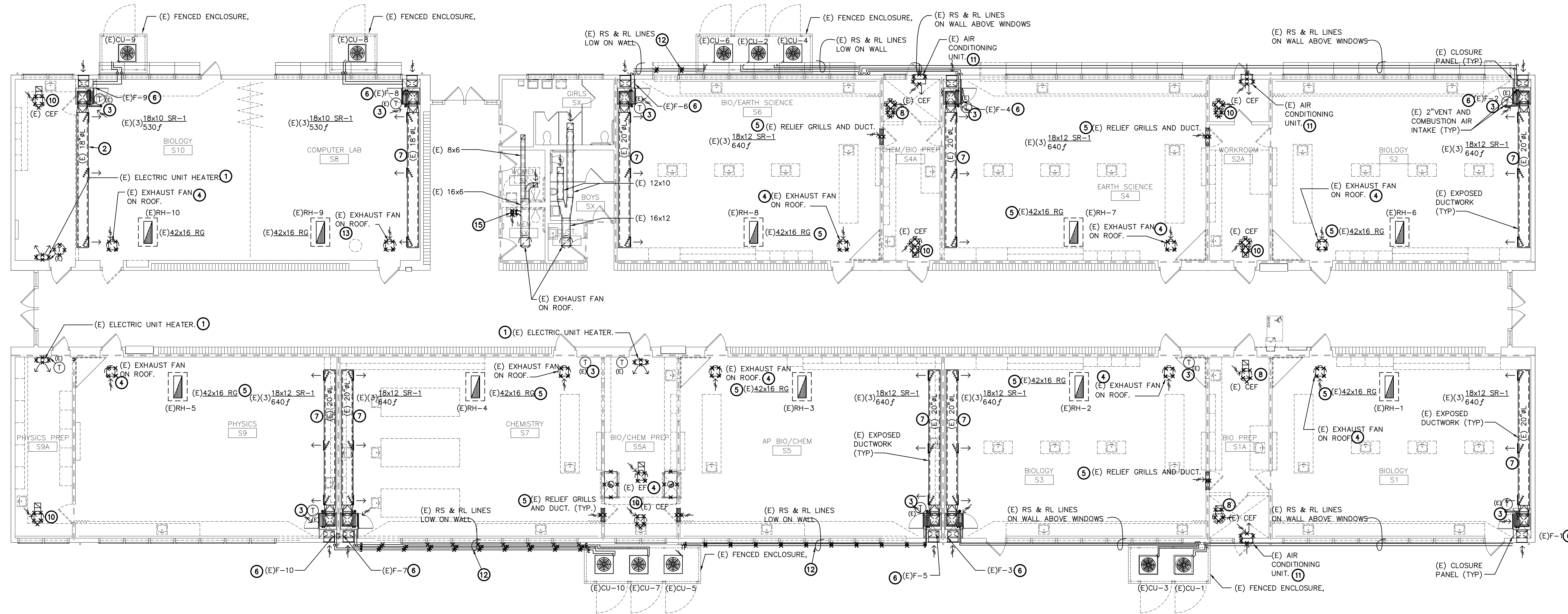

Building - HVAC Demolition Floor Plan

SCALE : 1/8" = 1'-0"

1
M2.0

DEMOLITION SHEET NOTES

- ① REMOVE EXISTING ELECTRIC UNIT HEATER, SUPPORTS ALL CONTROLS AND DISCONNECT ELECTRICAL.
- ② DISCONNECT AND REMOVE EXISTING WALL MOUNTED DUCTWORK, GRILLES AND SUPPORTS. SET ASIDE AND STORE IN SECURE LOCATION FOR RE-INSTALLATION AFTER WALL REMOVAL. SEE 1/M2.1 FOR NEW WORK.
- ③ EXISTING THERMOSTAT ON FURNACE ENCLOSURE TO REMAIN IN PLACE.
- ④ REMOVE EXISTING ROOF EXHAUST FAN, CURB, GRILLE AND WALL SWITCH. PREPARE OPENING FOR NEW ROOF EXHAUST FAN AND SWITCH INSTALLATION. SEE 1/M2.1 FOR NEW WORK.
- ⑤ REMOVE EXISTING RELIEF GRILLE AND DUCTWORK. PATCH AND REPAIR WALL OPENING. SEE ARCH'L DWGS FOR INFILL DETAILS.
- ⑥ EXISTING FURNACE IN "TEAM AIR" ENCLOSURE TO REMAIN IN PLACE.
- ⑦ EXISTING EXPOSED DUCTWORK AND GRILLES TO REMAIN IN PLACE.
- ⑧ REMOVE EXISTING CEILING EXHAUST FAN, ROOF JACK AND ALL CONTROLS. PATCH AND SEAL EXISTING ROOF OPENING.
- ⑨ EXISTING CEILING EXHAUST FAN AND WALL SWITCH TO REMAIN IN PLACE. REMOVE EXISTING GRILLE, CLEAN, PAINT AND RE-INSTALL TO MATCH NEW CEILING PAINT.
- ⑩ REMOVE EXISTING CEILING EXHAUST FAN AND WALL SWITCH. PREPARE CEILING OPENING FOR NEW EXHAUST FAN INSTALLATION. SEE 1/M2.1 FOR NEW WORK.

- ⑪ REMOVE EXISTING WALL MOUNTED AIR CONDITIONER, LOUVER AND ALL CONTROLS AND SUPPORTS. PATCH AND SEAL EXISTING WALL OPENING.
- ⑫ REMOVE EXISTING REFRIGERANT TUBING ON WALL. DISCONNECT, EVACUATE AND CAPTURE EXISTING REFRIGERANT AND TEMPORARILY CAP TUBING ENDS. SET ASIDE REMOVED SECTIONS OF REFRIGERANT PIPING FOR REINSTALLATION. SEE 1/M2.1 FOR NEW WORK.
- ⑬ REMOVE EXISTING ROOF EXHAUST FAN, GRILLE AND WALL SWITCH. PATCH AND SEAL EXISTING ROOF OPENING.
- ⑭ REMOVE EXISTING FUME HOOD, EXHAUST FAN, DUCT THRU ROOF AND ROOF CAP. REMOVE ALL EXISTING CONTROLS. PATCH AND SEAL EXISTING ROOF OPENING.
- ⑮ REMOVE EXISTING EXHAUST GRILLE AND DUCT THRU CEILING. CAP AND PREPARE EXISTING DUCT FOR EXTENSION TO NEW GRILLE. SEE 1/M2.1 FOR NEW WORK.

DEMOLITION GENERAL NOTES

- 1. LOCATIONS OF EXISTING EQUIPMENT, DUCTWORK AND PIPING SHOWN ARE APPROXIMATE ONLY AND DO NOT NECESSARILY REPRESENT ALL EXISTING HVAC COMPONENTS THAT WILL REQUIRE REMOVAL OR ABANDONMENT FOR COMPLETION OF NEW WORK. CONTRACTOR SHALL FIELD VERIFY EXACT LOCATIONS AND NUMBER OF EXISTING HVAC COMPONENTS IN FIELD PRIOR TO BEGINNING WORK AND PROVIDE ALL NECESSARY DEMOLITION REQUIRED TO COMPLETE NEW WORK INDICATED ON PLANS.

Mt. Diablo High School
Building S - Science Lab Modernization
 2450 Grant Street
 Concord, California 94520
Mt. Diablo Unified School District



FILE NO. xx-xx
 IDENTIFICATION STAMP
 DIV. OF THE STATE ARCHITECT
 OFFICE OF REGULATION SERVICES
 APPLICATION NO. 01-
 AC. FLS. SS
 DATE

DIVISION OF THE STATE ARCHITECT
 revision date: by:



CAPITAL ENGINEERING
 CONSULTANTS, INC.
 RANCHO CORDOVA, CALIFORNIA
 CS/RL PROJECT NO. 121002.00

CONSULTANT

nacht&lewis
 800 G Street, Suite 100
 Sacramento, CA 95811
 www.nachtandlewis.com
 916.329.4000

ARCHITECT

REVISIONS		
NO.	DESCRIPTION	DATE / REV'D

DATE February 19, 2013
 JOB NO. Y1211.00
 SHEET TITLE

Building HVAC Demolition Plan

SHEET NO.
M2.0

SHEET ___ OF ___ TOTAL
 DSA SUBMITTAL SET

ONE INCH = TWENTY FEET
ONE INCH = TEN FEET
ONE INCH = FIVE FEET
ONE INCH = TWO FEET
ONE INCH = ONE FOOT
ONE-EIGHTH INCH = ONE FOOT
ONE-FOURTH INCH = ONE FOOT
ONE-HALF INCH = ONE FOOT
THREE-QUARTERS INCH = ONE FOOT
ONE INCH = ONE FOOT
ONE AND ONE-HALF INCH = ONE FOOT

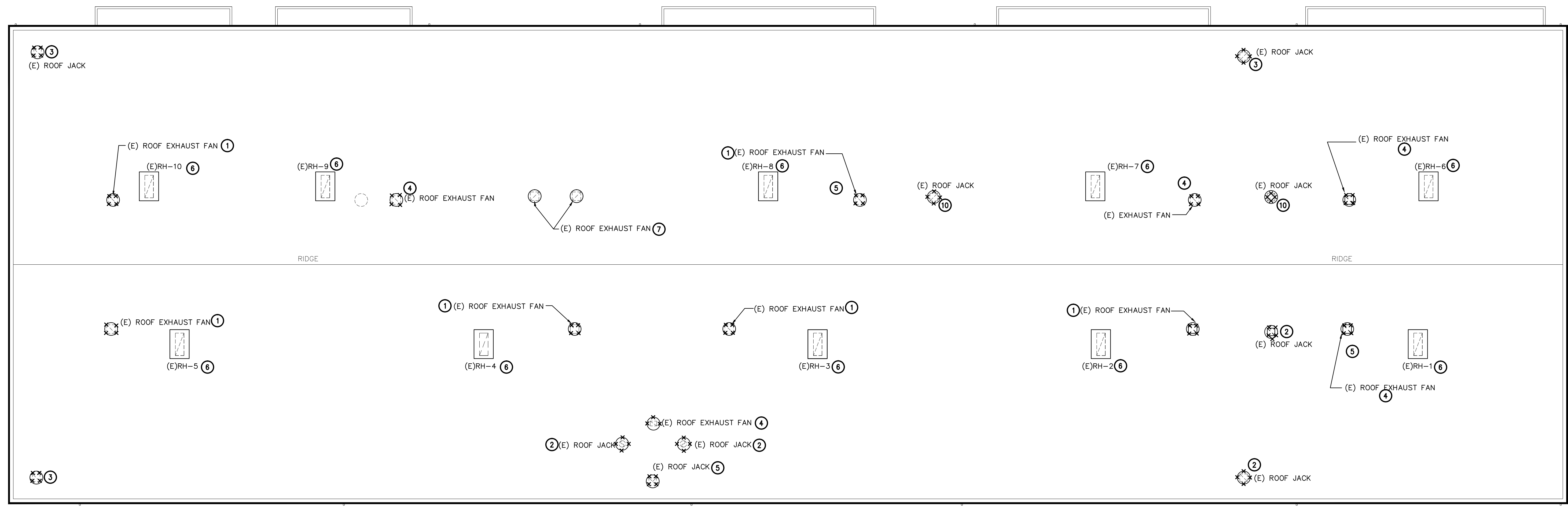

Building - HVAC Demolition Roof Plan

1
M4.0

SCALE : 1/8" = 1'-0"

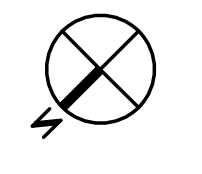

DEMOLITION SHEET NOTES

- ① REMOVE EXISTING ROOF EXHAUST FAN AND CURB. PREPARE OPENING FOR NEW ROOF EXHAUST FAN SEE 1/M4.1 FOR NEW WORK.
- ② REMOVE EXISTING ROOF JACK. PATCH AND SEAL EXISTING ROOF OPENING AND REPAIR ROOF PER DISTRICT STANDARDS.
- ③ REMOVE EXISTING ROOF JACK. PREPARE FOR NEW CEILING EXHAUST FAN AND ROOF JACK INSTALLATION. SEE 1/M2.1 AND 1/M4.1 FOR NEW WORK.
- ④ REMOVE EXISTING ROOF EXHAUST FAN, PATCH AND SEAL EXISTING ROOF OPENING AND REPAIR ROOF PER DISTRICT STANDARDS.
- ⑤ REMOVE EXISTING ROOF JACK. PREPARE FOR NEW ROOF EXHAUST FAN INSTALLATION. SEE 1/M2.1 AND 1/M4.1 FOR NEW WORK.
- ⑥ EXISTING RELIEF HOOD TO REMAIN IN PLACE.
- ⑦ EXISTING ROOF EXHAUST FAN TO REMAIN IN PLACE.

DEMOLITION GENERAL NOTES

- 1. LOCATIONS OF EXISTING EQUIPMENT, DUCTWORK AND PIPING SHOWN ARE APPROXIMATE ONLY AND DO NOT NECESSARILY REPRESENT ALL EXISTING HVAC COMPONENTS THAT WILL REQUIRE REMOVAL OR ABANDONMENT FOR COMPLETION OF NEW WORK. CONTRACTOR SHALL FIELD VERIFY EXACT LOCATIONS AND NUMBER OF EXISTING HVAC COMPONENTS IN FIELD PRIOR TO BEGINNING WORK AND PROVIDE ALL NECESSARY DEMOLITION REQUIRED TO COMPLETE NEW WORK INDICATED ON PLANS.

**Mt. Diablo High School
Building S - Science Lab Modernization**
2450 Grant Street
Concord, California 94520
Mt. Diablo Unified School District



FILE NO. xx-xx
IDENTIFICATION STAMP
DIV. OF THE STATE ARCHITECT
OFFICE OF REGULATION SERVICES
APPLICATION NO. 01-
AC. FLS. SS
DATE

DIVISION OF THE STATE ARCHITECT
revision date: by:



DATE SIGNED: _____
**CAPITAL ENGINEERING
CONSULTANTS, INC.**
RANCHO CORDOVA, CALIFORNIA
CS/SJL 12/02/00
PM - DESIGN TEAM PROJECT NO.

CONSULTANT

nacht&lewis
800 G Street, Suite 100
Sacramento, CA 95811
www.nachtlewis.com
916.329.4000

ARCHITECT

NO.	DESCRIPTION	DATE	REV'D

DATE February 19, 2013

JOB NO. Y1211.00

SHEET TITLE

**Building
HVAC
Demolition
Roof Plan**

SHEET NO.

M4.0

SHEET ___ OF ___ TOTAL
DSA SUBMITTAL SET

ONE INCH = TWENTY FEET
ONE INCH = TEN FEET
ONE EIGHTH INCH = ONE FOOT
ONE QUARTER INCH = ONE FOOT
ONE HALF INCH = ONE FOOT
THREE QUARTERS INCH = ONE FOOT
ONE INCH = ONE FOOT
ONE AND ONE HALF INCH = ONE FOOT

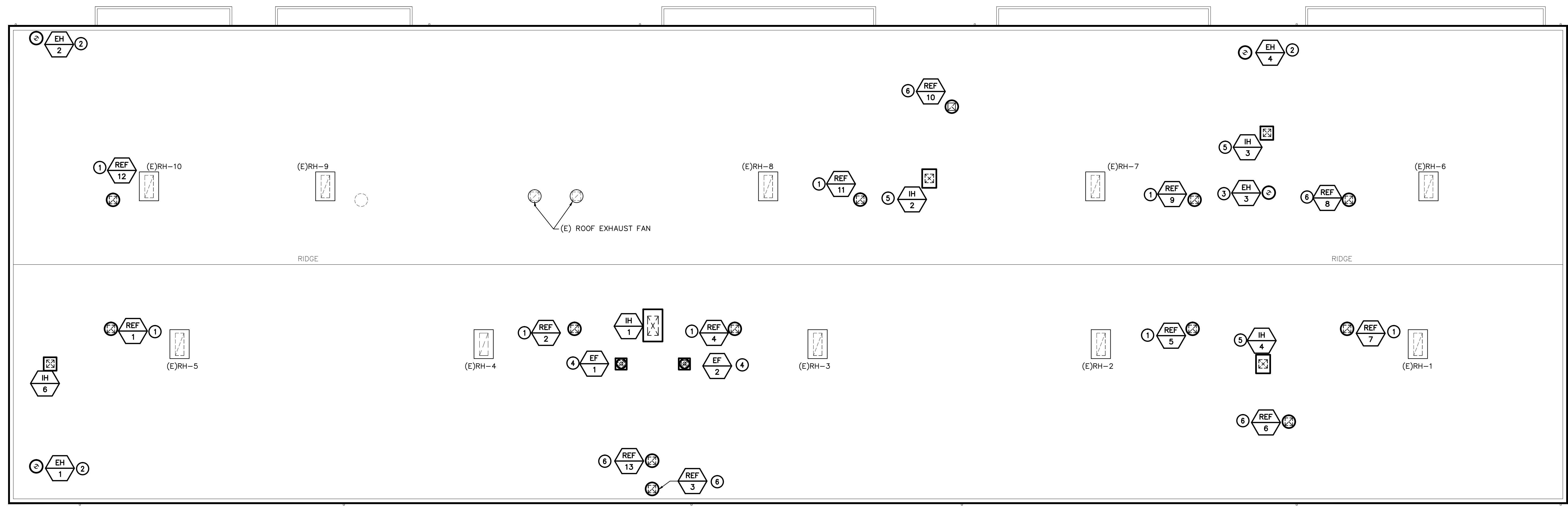

Building - HVAC Roof Plan

SCALE : 1/8" = 1'-0"

1
M4.1

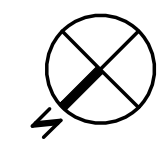

SHEET NOTES

- ① INSTALL NEW ROOF EXHAUST FAN AND CURB OVER EXISTING ROOF OPENING. SEE 5/M5.1.
- ② INSTALL NEW EXHAUST HOOD AND CURB OVER EXISTING ROOF OPENING. SEE 1/M5.1.
- ③ INSTALL NEW EXHAUST HOOD AND CURB SEE 1/M5.1.
- ④ INSTALL NEW LAB EXHAUST FAN AND CURB SEE 2/M5.1.
- ⑤ INSTALL NEW INTAKE HOOD AND CURB SEE 1/M5.1.
- ⑥ INSTALL NEW ROOF EXHAUST FAN AND CURB SEE 5/M5.1.

GENERAL NOTES

- 1. LOCATIONS OF EXISTING EQUIPMENT, DUCTWORK AND PIPING SHOWN ARE APPROXIMATE ONLY AND DO NOT NECESSARILY REPRESENT ALL EXISTING HVAC COMPONENTS THAT WILL REQUIRE REMOVAL OR ABANDONMENT FOR COMPLETION OF NEW WORK. CONTRACTOR SHALL FIELD VERIFY EXACT LOCATIONS AND NUMBER OF EXISTING HVAC COMPONENTS IN FIELD PRIOR TO BEGINNING WORK AND PROVIDE ALL NECESSARY DEMOLITION REQUIRED TO COMPLETE NEW WORK INDICATED ON PLANS.

MDUSD
Mt. Diablo High School
Building S - Science Lab Modernization

2450 Grant Street
 Concord, California 94520

Mt. Diablo Unified School District



FILE NO. xx-xx
 IDENTIFICATION STAMP
 DIV. OF THE STATE ARCHITECT
 OFFICE OF REGULATION SERVICES

APPLICATION NO.
 01-
 AC. FLS. SS
 DATE

DIVISION OF THE STATE ARCHITECT
revision date: by:



DATE SIGNED: _____

CAPITAL ENGINEERING CONSULTANTS, INC.
 RANCHO CORDOVA, CALIFORNIA

CS/SL 12002.00
 PM - DESIGN TEAM PROJECT NO.

CONSULTANT

nacht&lewis

800 G Street, Suite 100
 Sacramento, CA 95811
 www.nachtlewis.com
 916.329.4000

ARCHITECT

REVISIONS			
NO.	DESCRIPTION	DATE	REV'D

DATE February 19, 2013
 JOB NO. Y1211.00
 SHEET TITLE

Building HVAC Roof Plan

SHEET NO.
M4.1

SHEET ___ OF ___ TOTAL
 DSA SUBMITTAL SET

ONE AND ONE-HALF INCH = ONE FOOT
 ONE INCH = ONE FOOT
 THREE-QUARTERS INCH = ONE FOOT
 ONE-HALF INCH = ONE FOOT
 ONE-QUARTER INCH = ONE FOOT
 ONE-EIGHTH INCH = ONE FOOT
 ONE-SIXTEENTH INCH = ONE FOOT
 ONE INCH = TWENTY FEET

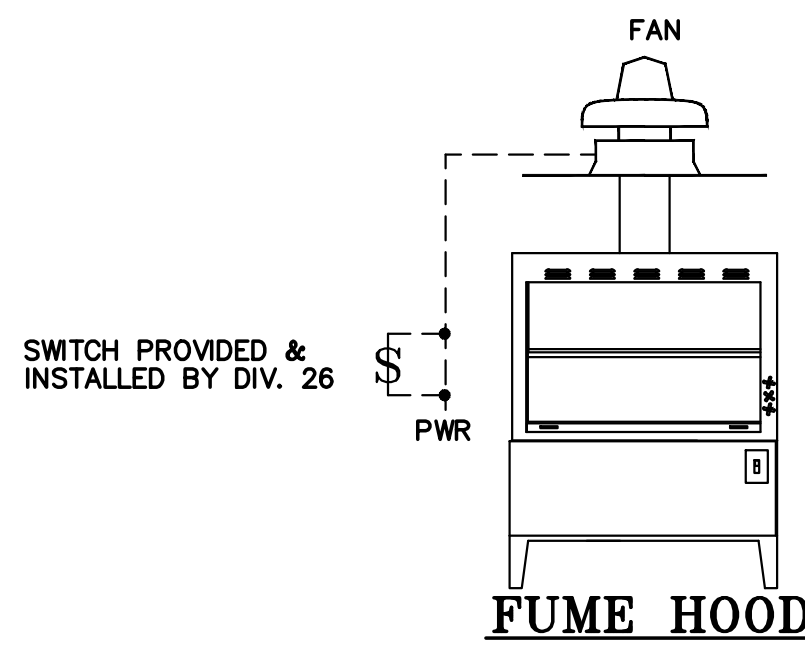

FUME HOOD CONTROL DIAGRAM

SCALE : NONE

10
M5.1

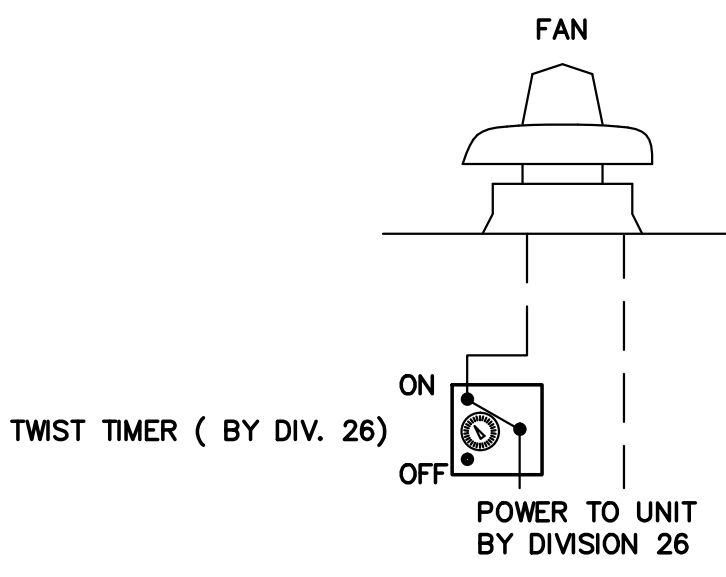

EXHAUST FAN w/ TWIST TIMER DIAGRAM

SCALE : NONE

7
M5.1

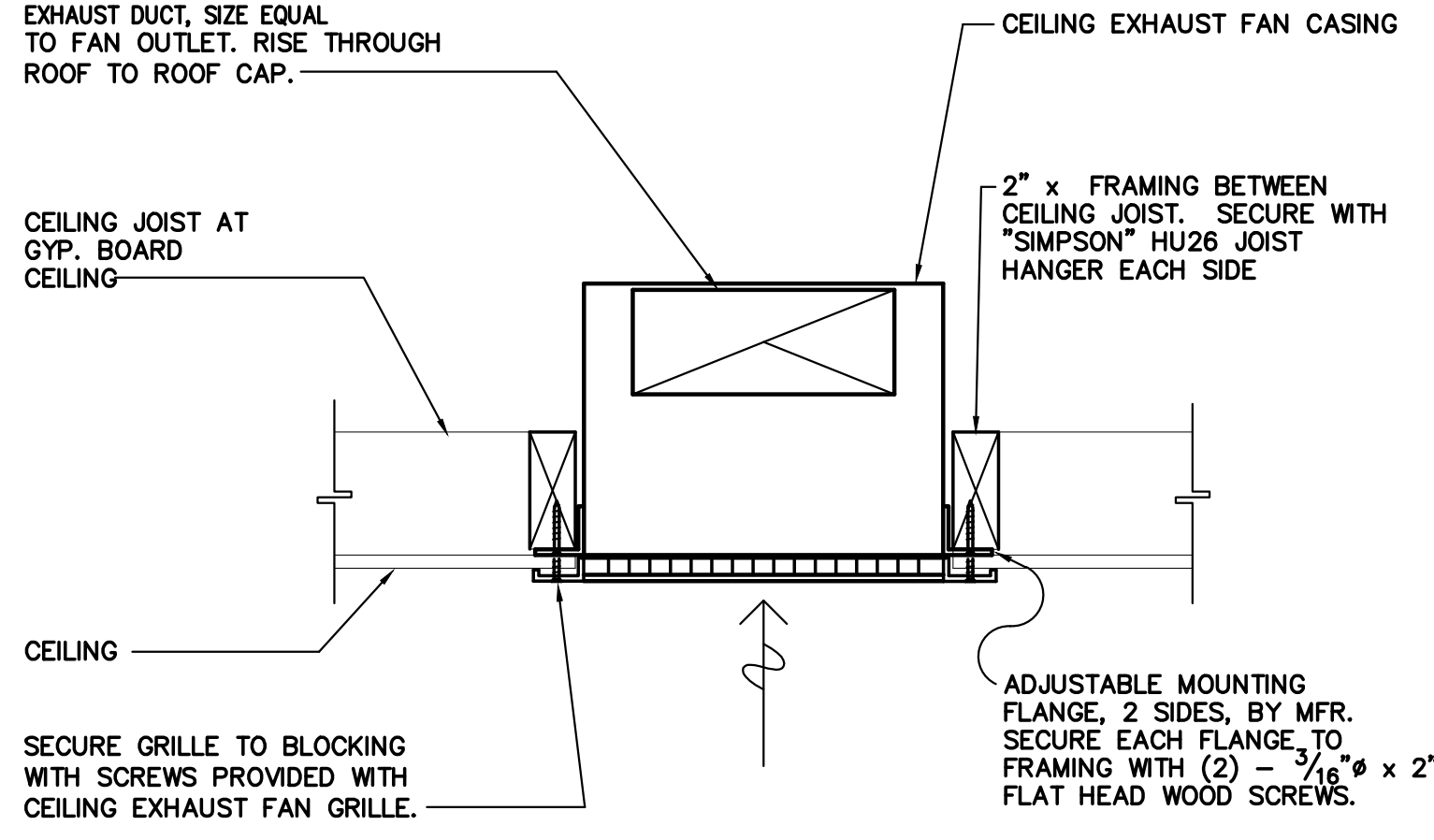

TYPICAL C.E.F. MOUNTING

SCALE : NONE

4
M5.1

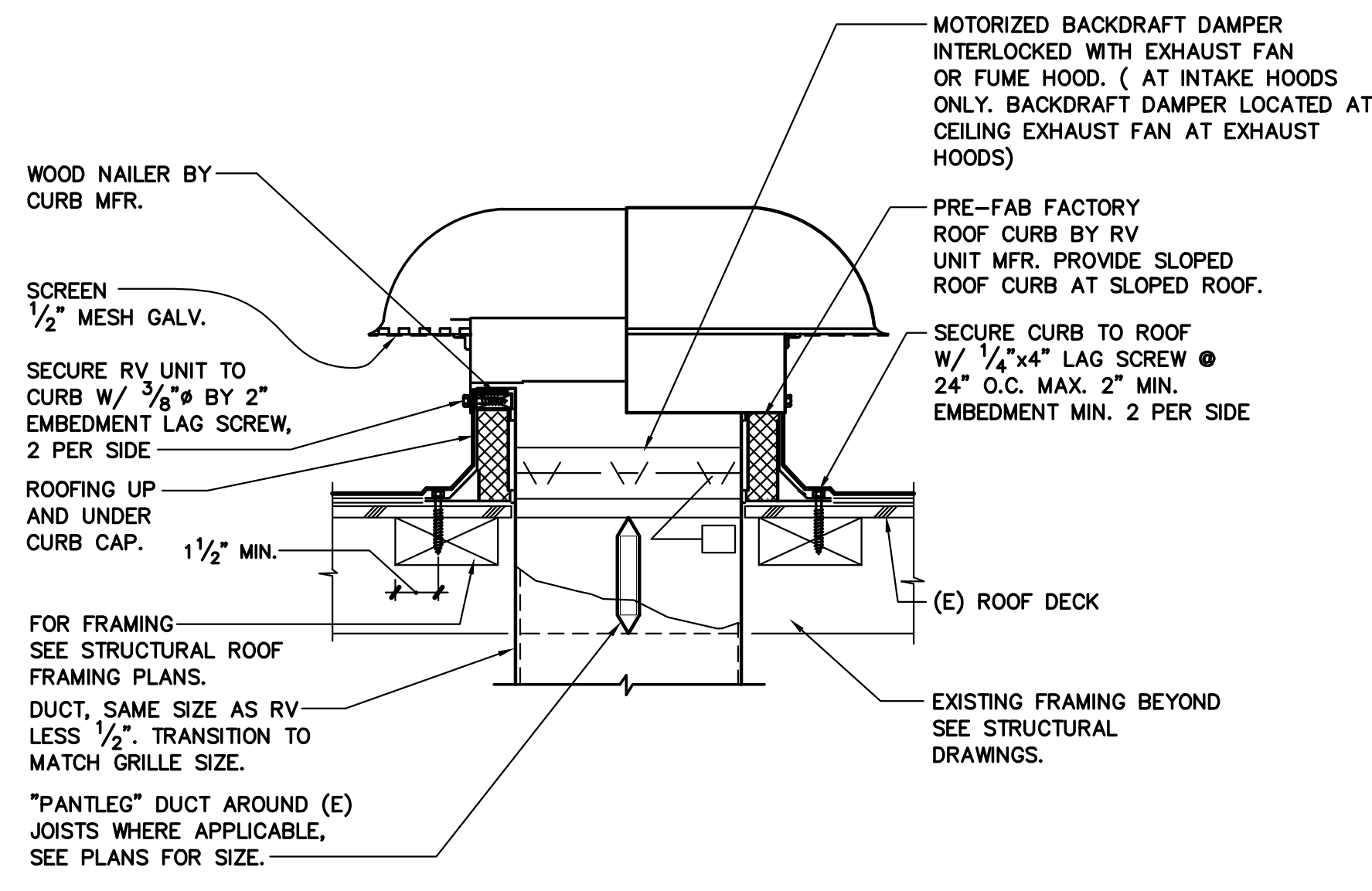

INTAKE/EXHAUST HOOD DETAIL

SCALE : NONE

1
M5.1

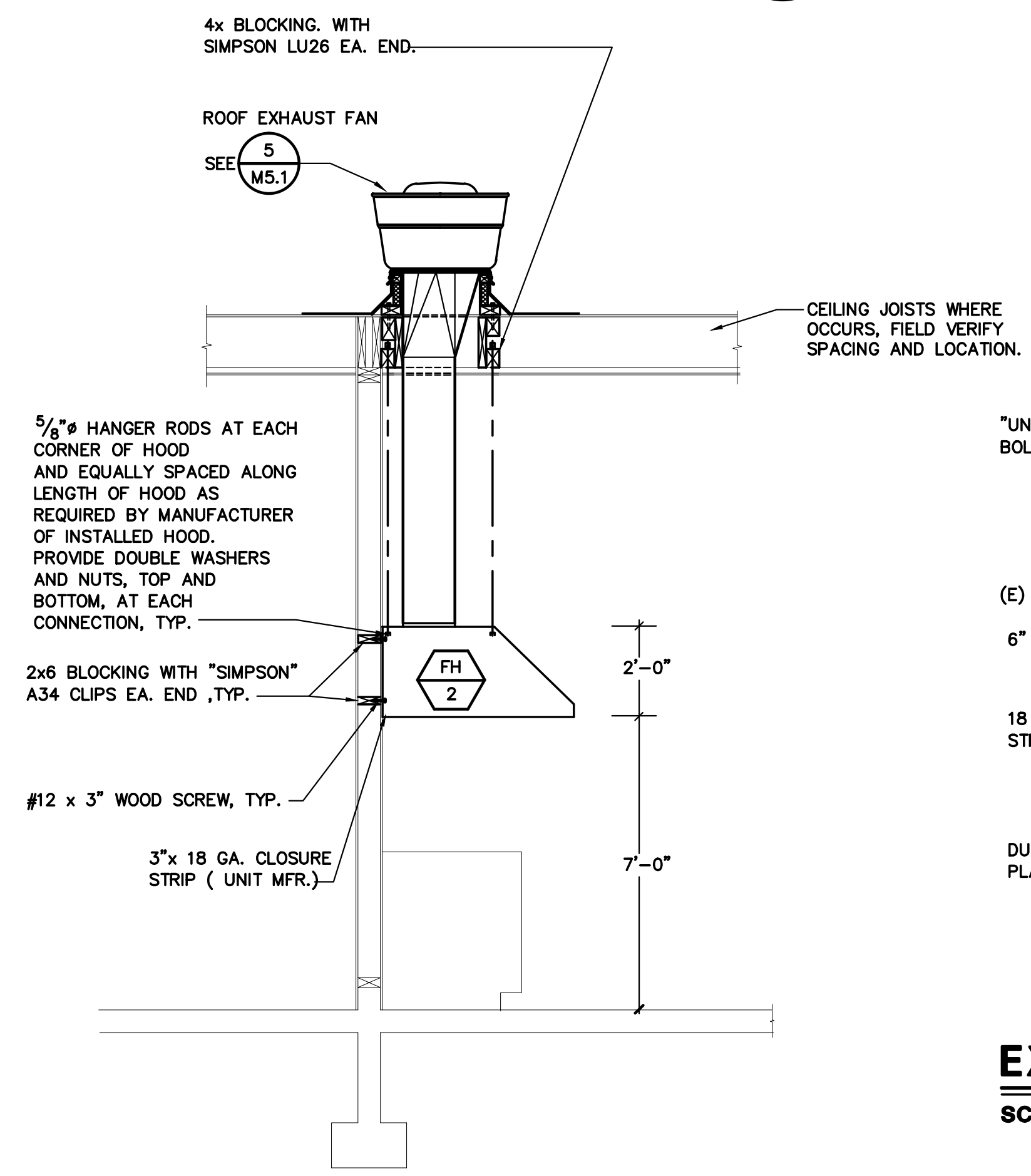

EXPOSED DUCT HANGER DETAIL

SCALE : NONE

8
M5.1

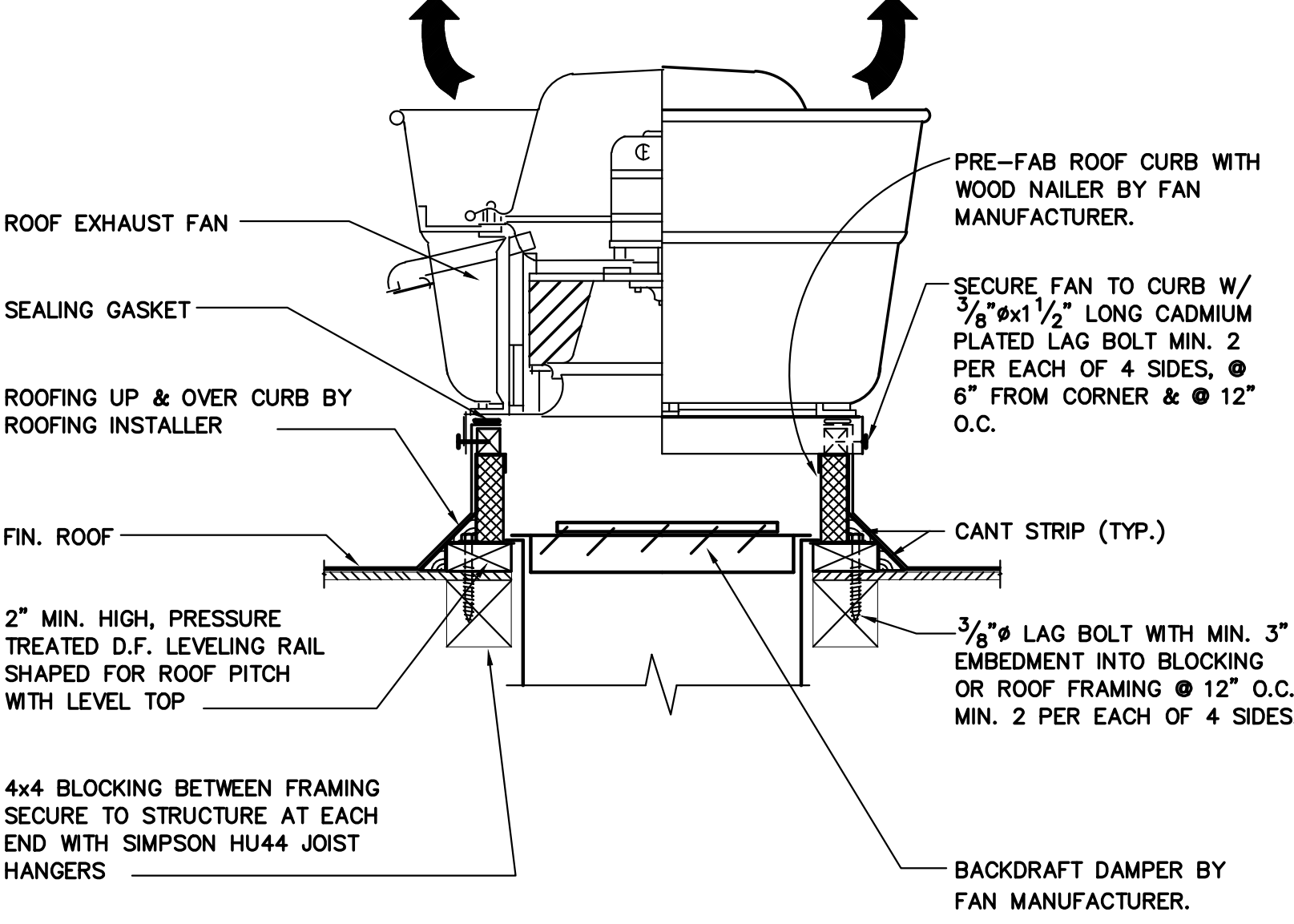

REF MOUNTING DETAIL

SCALE : NONE

5
M5.1

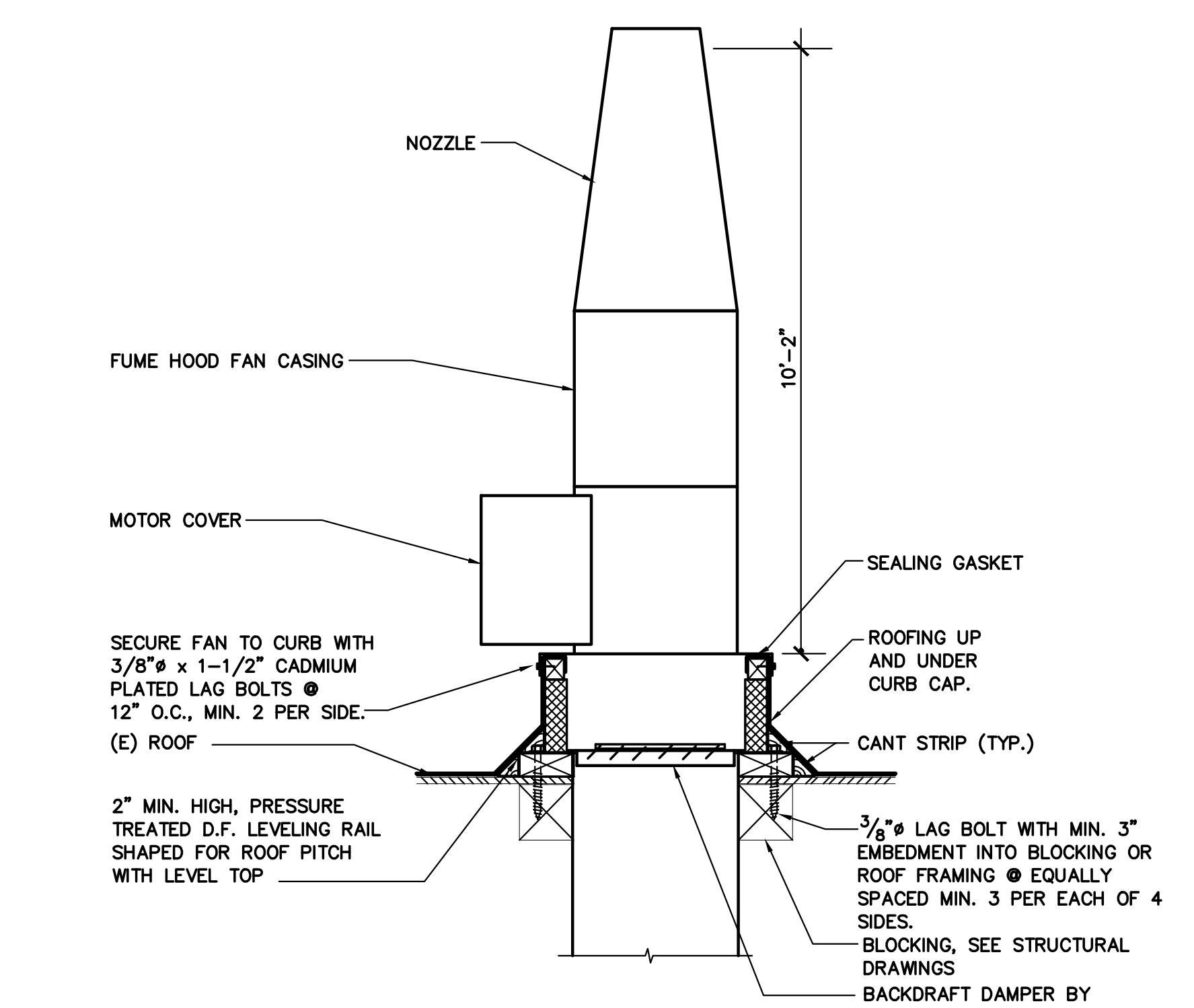

EF-1 & 2 MOUNTING DETAIL

SCALE : NONE

2
M5.1

FH-2 HOOD MOUNTING

SCALE : NONE

11
M5.1

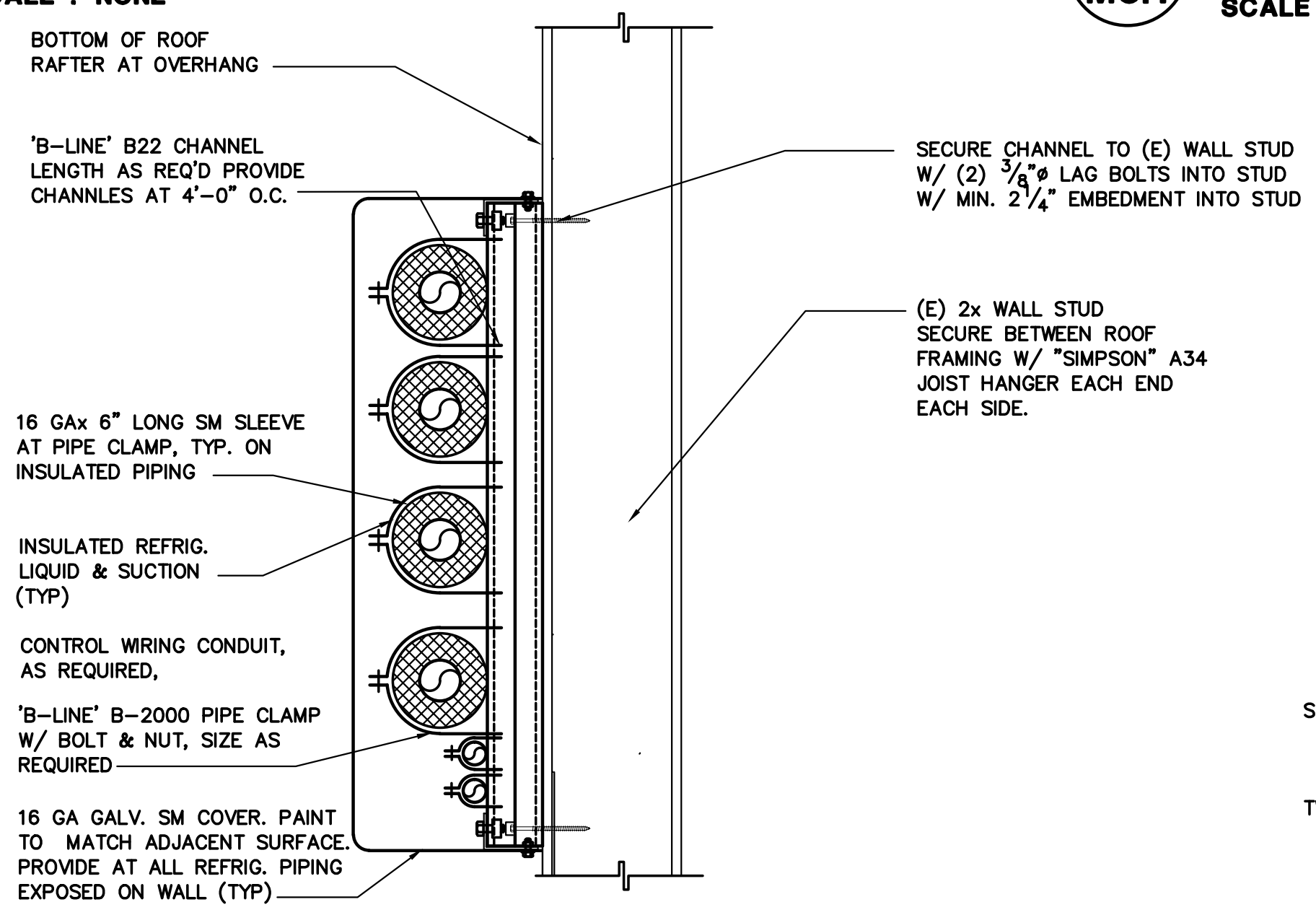

REFRIGERANT PIPING AT WALL

SCALE : NONE

9
M5.1

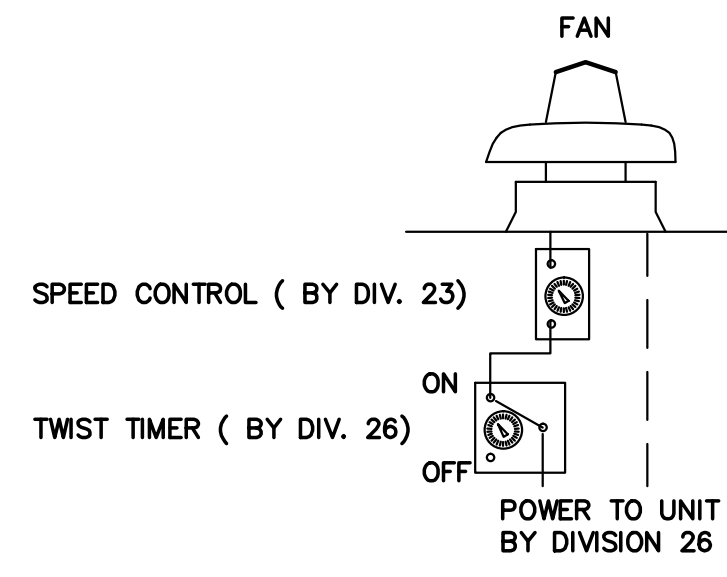

EXHAUST FAN w/ SPEED CONTROL DIAGRAM

SCALE : NONE

6
M5.1

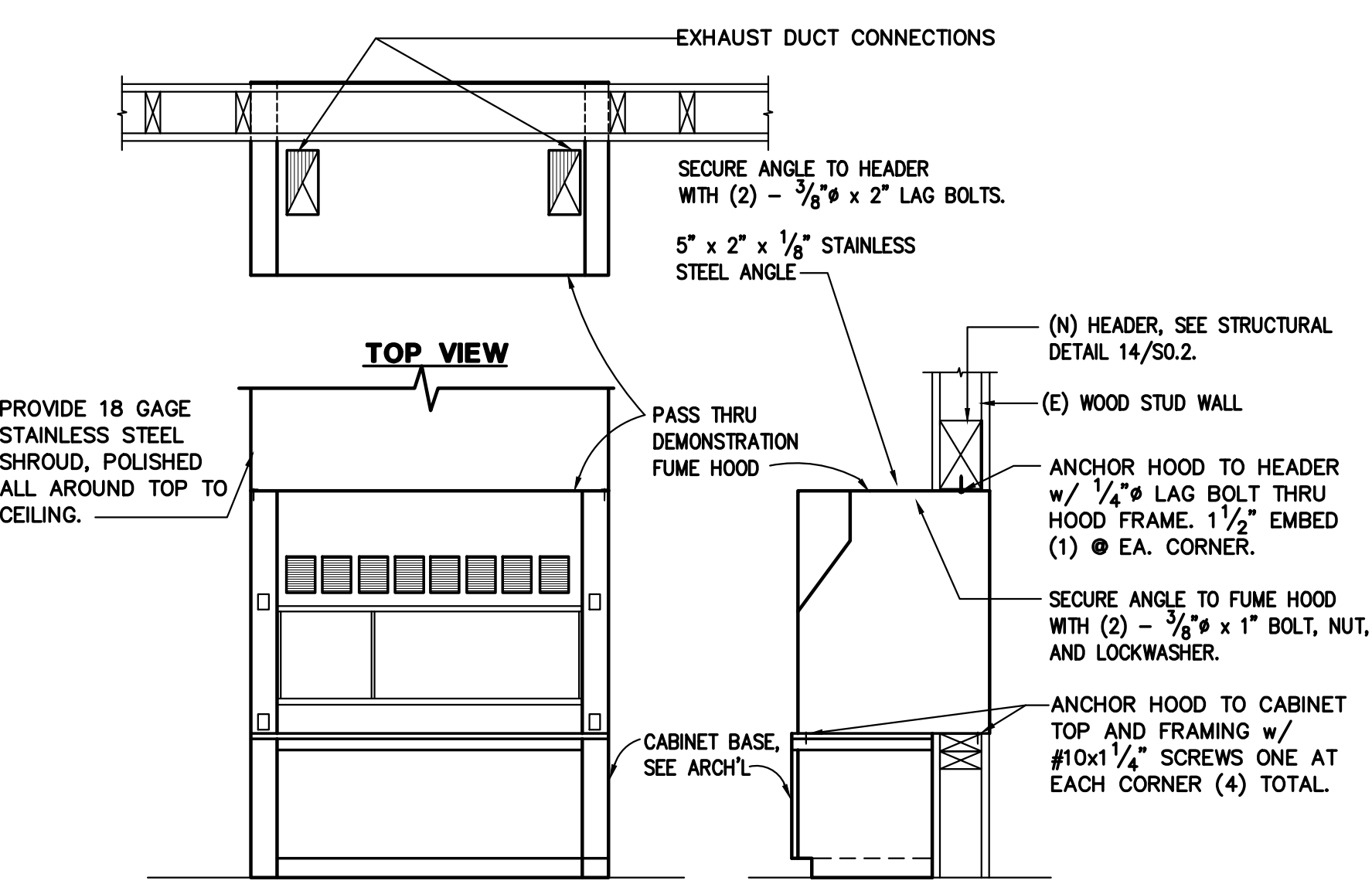

FUME HOOD MOUNTING DETAIL

SCALE : NONE

3
M5.1

UNDER GROUND REFRIGERANT PIPING

SCALE : NONE

12
M5.1

Mt. Diablo High School
 Building S - Science Lab Modernization
 2450 Grant Street
 Concord, California 94520
 Mt. Diablo Unified School District



FILE NO. xx-xx
 IDENTIFICATION STAMP
 DIV. OF THE STATE ARCHITECT
 OFFICE OF REGULATION SERVICES
 APPLICATION NO. 01-
 AC. FLS. 88
 DATE

DIVISION OF THE STATE ARCHITECT
 revision date: by:



CAPITAL ENGINEERING CONSULTANTS, INC.
 RANCHO CORDOVA, CALIFORNIA
 CS/S/L 12/02/00
 PM - DESIGN TEAM PROJECT NO.

CONSULTANT

nacht&lewis
 800 G Street, Suite 100
 Sacramento, CA 95811
 www.nachtlewis.com
 916.329.4000

ARCHITECT

REVIEWS

NO.	DESCRIPTION	DATE	REV'D

DATE February 19, 2013
 JOB NO. Y1211.00
 SHEET TITLE

HVAC
 Details

SHEET NO.

M5.1

SHEET ___ OF ___ TOTAL
 DSA SUBMITTAL SET

ONE INCH = TWENTY FEET
 ONE-SIXTEENTH INCH = ONE FOOT
 ONE-EIGHTH INCH = ONE FOOT
 ONE-FOURTH INCH = ONE FOOT
 ONE-HALF INCH = ONE FOOT
 THREE-QUARTERS INCH = ONE FOOT
 ONE INCH = ONE FOOT
 ONE AND ONE-HALF INCH = ONE FOOT

PLUMBING LEGEND		
SYMBOL	ABBREVIATION	DESCRIPTION
	ABC	ABOVE CEILING
	AFF	ABOVE FINISHED FLOOR
	AFG	ABOVE FINISHED GRADE
	AF, BF	ABOVE FLOOR, BELOW FLOOR
	AD, AP	ACCESS DOOR, ACCESS PANEL
	AW	ACID WASTE BELOW FLOOR
	AW	ACID WASTE ABOVE FLOOR
	AV	ACID VENT PIPING
	BV	BALL VALVE
		BRANCH - TOP CONNECTION
		BRANCH - BOTTOM CONNECTION
		BRANCH - SIDE CONNECTION
	CEP	CAP ON END OF PIPE
	CB, RD	CATCH BASIN, ROOF DRAIN
		CENTER LINE
	CW	COLD WATER
	CMH, HMH, VH	COLD WATER HEADER, HOT WATER HEADER, VENT HEADER
	CR	CONCENTRIC REDUCER
	CD	CONDENSATE DRAIN LINE
	PCD	PUMPED CONDENSATE DRAIN
	CO	CLEANOUT
	DI	DEIONIZED WATER
	F	DEGREES FAHRENHEIT
	φ, □	DIAMETER, SQUARE (FEET)
	(E)	EXISTING TO BE REMOVED
	EJ	EXPANSION JOINT
	FF=	FINISHED FLOOR ELEVATION
	FU	FIXTURE UNIT
	CO	FLOOR CLEANOUT
	FD	FLOOR DRAIN
	FS	FLOOR SINK
		FLOW IN DIRECTION OF ARROW
	FV, FT	FLUSH VALVE, FLUSH TANK
	(FA), (TA)	FROM ABOVE, TO ABOVE
	(FB), (TB)	FROM BELOW, TO BELOW
	GSCK, PC	GAS COOK, PLUG COCK
	G	GAS - LOW PRESSURE
	GR	GAS PRESSURE REGULATOR
	GV	GATE VALVE
	GPM	GALLONS PER MINUTE
	GLV	GLOBE VALVE
	CO	GRADE CLEANOUT
	HD	HOPPER DRAIN, HUB DRAIN
	HB	HOSE BIBB
	HW	HOT WATER PIPING
	D	INDIRECT DRAIN, CONDENSATE DRAIN
	(N), (E)	NEW, EXISTING
	(NTS)	NOT TO SCALE
	OH	OVERHEAD
		PIPE GUIDE
		PIPE IN SLEEVE
		PITCH DOWN IN DIRECTION OF FLOW
	POC	POINT OF CONNECTION
	PD	PUMP DISCHARGE LINE
	WH	RECESSED BOX HOSE BIBB OR WALL HYDRANT
	RE, IE	RIM ELEVATION, INVERT ELEVATION
	(R), (D)	RISE, DROP
		RISE DOWN (ELBOW)
		RISE UP (ELBOW)
		RISE OR DROP
	R, D	ROOF DRAIN
	S, W	SOIL, WASTE OR SANITARY SEWER BELOW FLOOR
	SD	STORM DRAIN
	T	TEMPERED WATER SUPPLY
	TP	TRAP PRIMER
	TP	TRAP PRIMER PIPING
	TYP	TYPICAL
	UN	UNION OR FLANGE
		VALVE IN RISER (TYPE AS INDICATED OR NOTED)
	VB	VALVE IN VALVE BOX (VALVE TYPE SYMBOL AS REQUIRED FOR VALVE TYPE USED)
	V	VENT PIPING
	V, VR, VTR	VENT, VENT RISER, VENT THRU ROOF
	WCO	WALL CLEANOUT
	WHA	WATER HAMMER ARRESTOR

- ### PLUMBING GENERAL NOTES
- SEE ARCHITECTURAL DRAWINGS FOR BUILDING DIMENSIONS AND EXACT LOCATIONS OF PLUMBING FIXTURES.
 - COORDINATE LOCATION OF PIPING WITH OTHER TRADES ON THIS PROJECT.
 - CONCEAL ALL PIPING IN WALL FURRING, PARTITIONS, ETC., EXCEPT AT MECHANICAL ROOMS.
 - PROVIDE BALL VALVES ON WATER PIPE BRANCHES TO EQUIPMENT AND PLUMBING FIXTURES. PROVIDE ACCESS PANELS WHEN LOCATED IN FURRED SPACES OR ABOVE NON-REMOVABLE CEILINGS. ALL VALVES SHALL BE FULL LINE SIZE.
 - SEAL ALL PIPE PENETRATIONS THRU FLOORS WATERTIGHT.
 - PROVIDE GAS SHUT-OFF VALVE, UNION AND DIRT LEG AT EACH GAS CONNECTION TO MECHANICAL EQUIPMENT.
 - DOMESTIC HOT WATER HEATERS SHALL BE SEISMICALLY SECURED TO BUILDING STRUCTURE WITH ADEQUATE STRUCTURAL SUPPORT WITH ANCHOR BOLTS TO WITHSTAND 0.29 LATERAL AND VERTICAL LOADS.
 - PRIOR TO ANY SOLENOID VALVE, QUICK CLOSING VALVE, ETC. PROVIDE AND INSTALL SHOCK ABSORBER OF REQUIRED SIZE.
 - PENETRATIONS OF RATED ASSEMBLIES SHALL BE FIRE-STOPPED. FIRE STOPPING SHALL BE AN APPROVED MATERIAL OF THE ENFORCING AGENCY.
 - OFFSET VENTS THRU ROOF 10 FEET MINIMUM FROM AIR INTAKES AND 4 FEET FROM OUTSIDE WALLS.
 - CONDENSATE DRAIN LINE CONNECTIONS TO MECHANICAL UNITS SHALL INCLUDE MINIMUM 4" DEEP "P" TRAP AND CLEANOUTS AT ALL OFFSETS.
 - ALL MECHANICAL UNITS ARE SHOWN FOR REFERENCE AND COORDINATION ONLY. SEE "M" SHEETS.
 - OFFSET ALL RISERS AND DROPS TO AVOID PENETRATIONS AT TOP PLATES.
 - FIELD VERIFY EXACT SIZES, LOCATIONS AND ELEVATIONS OF ALL PIPING CONNECTIONS, OTHER WORK, ETC., PRIOR TO TRENCHING OR INSTALLING OF ANY NEW WORK.
 - BUILDING SEWER, WATER AND STORM DRAIN RUN APPROXIMATELY 5' MIN. FROM BUILDING, SECTION 15400 APPLIES TO UTILITIES IN THE BUILDING, UNDER THE BUILDING AND TO 5' OUTSIDE THE BUILDING, BEYOND THE 5' OUTSIDE OF THE BUILDING SECTION 02700 GOVERNS.

- ### MEP COMPONENT ANCHORAGE NOTE
- ALL MECHANICAL, PLUMBING, AND ELECTRICAL COMPONENTS SHALL BE ANCHORED AND INSTALLED PER THE DETAILS ON THE DSA APPROVED CONSTRUCTION DOCUMENTS. WHERE NO DETAIL IS INDICATED, THE FOLLOWING COMPONENTS SHALL BE ANCHORED OR BRACED TO MEET THE FORCE AND DISPLACEMENT REQUIREMENTS PRESCRIBED IN THE 2010 CBC, SECTIONS 1615A.1.12 THROUGH 1615A.1.22 AND ASCE 7-05 CHAPTER 6 AND 13.
- ALL PERMANENT EQUIPMENT AND COMPONENTS.
 - TEMPORARY OR MOVABLE EQUIPMENT THAT IS PERMANENTLY ATTACHED (e.g. HARD WIRED) TO THE BUILDING UTILITY SERVICES SUCH AS ELECTRICITY, GAS OR WATER.
 - MOVABLE EQUIPMENT WHICH IS STATIONED IN ONE PLACE FOR MORE THAN 8 HOURS AND HEAVIER THAN 400 POUNDS ARE REQUIRED TO BE ANCHORED WITH TEMPORARY ATTACHMENTS.
- THE ATTACHMENT OF THE FOLLOWING MECHANICAL AND ELECTRICAL COMPONENTS SHALL BE POSITELY ATTACHED TO THE STRUCTURE, BUT NEED NOT BE DETAILED ON THE PLANS. THESE COMPONENTS SHALL HAVE FLEXIBLE CONNECTIONS PROVIDED BETWEEN THE COMPONENT AND ASSOCIATED DUCTWORK, PIPING, AND CONDUIT.
- COMPONENTS WEIGHING LESS THAN 400 POUNDS AND HAVE A CENTER OF MASS LOCATED 4 FEET OR LESS ABOVE THE ADJACENT FLOOR OR ROOF LEVEL THAT DIRECTLY SUPPORT THE COMPONENT.
 - COMPONENTS WEIGHING LESS THAN 20 POUNDS, OR IN THE CASE OF DISTRIBUTION SYSTEMS, LESS THAN 5 POUNDS PER FOOT, WHICH ARE SUSPENDED FROM A ROOF OR FLOOR OR HUNG FROM A WALL.
- FOR THOSE ELEMENTS THAT DO NOT REQUIRE DETAILS ON THE APPROVED DRAWINGS, THE INSTALLATION SHALL BE SUBJECT TO THE APPROVAL OF THE STRUCTURAL ENGINEER OF RECORD AND THE DSA DISTRICT STRUCTURAL ENGINEER. THE PROJECT INSPECTOR WILL VERIFY THAT ALL COMPONENTS AND EQUIPMENT HAVE BEEN ANCHORED IN ACCORDANCE WITH ABOVE REQUIREMENTS.

- ### PIPING, DUCTWORK & ELECTRICAL DISTRIBUTION SYSTEM BRACING NOTE
- PIPING, DUCTWORK, AND ELECTRICAL DISTRIBUTION SYSTEMS SHALL BE BRACED TO COMPLY WITH THE FORCES AND DISPLACEMENTS PRESCRIBED IN ASCE 7-05 SECTION 13.3 AS DEFINED IN ASCE 7-05 SECTION 13.6.8, 13.6.7, 13.6.5.6, AND 2010 CBC, SECTIONS 1615A.1.20, 1615A.1.21 AND 1615A.1.22.
- THE BRACING AND ATTACHMENTS TO THE STRUCTURE SHALL BE DETAILED ON THE APPROVED DRAWINGS OR THEY SHALL COMPLY WITH ONE OF THE OSHPD PRE-APPROVALS (OPA #) AS MODIFIED TO SATISFY ANCHORAGE REQUIREMENTS OF ACT 318, APPENDIX D.
- COPIES OF THE MANUAL SHALL BE AVAILABLE ON THE JOBSITE PRIOR TO THE START OF HANGING THE BRACING OF THE PIPE, DUCTWORK, AND ELECTRICAL DISTRIBUTION SYSTEMS.
- THE STRUCTURAL ENGINEER OF RECORD SHALL VERIFY THE ADEQUACY OF THE STRUCTURE TO SUPPORT THE HANGER AND BRACE LOADS.

INSTANTANEOUS WATER HEATER SCHEDULE

UNIT	LOCATION	CHRONOMETER MODEL NO.	ΔT TEMP. RISE AT FLOW RATE	MAX. TEMP. SETTING	VOLTAGE WATTS	AMPS	DETAIL
IWH 1	S5A	E80XT	55°F / 1 GPM	120°F	208V/1φ / 8 KW	38	11 (P5.1)
IWH 2	S1A,S2A,S4A	M-20L	42°F / 1 GPM	105°F	208V/1φ / 6240	30	11 (P5.1)

ACID NEUTRALIZATION TANK SCHEDULE

UNIT	LOCATION	"ENFIELD" MODEL NO.	GALLONS	VOLUME CU. FT.	DETAIL	MONITORING SYSTEM	NOTES
ANT 1	--	CT0150	150	17.25	1-2-3 (P5.1)	"WATTS" PRO-SYSTEM 1	PROVIDE WITH "WATTS" MONITORING SYSTEM

Mt. Diablo High School
 Building S - Science Lab Modernization
 2450 Grant Street
 Concord, California 94520
 Mt. Diablo Unified School District



FILE NO. xx-xx
 IDENTIFICATION STAMP
 DIV. OF THE STATE ARCHITECT
 OFFICE OF REGULATION SERVICES
 APPLICATION NO. 01-
 AC. FLS. 88
 DATE

DIVISION OF THE STATE ARCHITECT
 revision date: by:



CAPITAL ENGINEERING CONSULTANTS, INC.
 RANCHO CORDOVA, CALIFORNIA
 CS/S/L
 PM - DESIGN TEAM 12002.00 PROJECT NO.

CONSULTANT

nacht&lewis
 800 G Street, Suite 100
 Sacramento, CA 95811
 www.nachtlewis.com
 916.329.4000

ARCHITECT

REVISIONS			
NO.	DESCRIPTION	DATE	REV'D

DATE February 19, 2013
 JOB NO. Y1211.00
 SHEET TITLE

Plumbing Legend & Notes
 SHEET NO.
 P0.1
 SHEET OF TOTAL
 DSA SUBMITTAL SET

PLUMBING FIXTURE SPECIFICATION & CONNECTION SCHEDULE

ADA	SYMBOL	FIXTURE	FIXTURE MANUFACTURER AND MODEL No.	FAUCET OR VALVE MANUFACTURER AND MODEL No.	TRIM MANUFACTURER AND MODEL No.	REMARKS	VENT	WASTE		COLD WATER		HOT WATER	
								BRANCH	OUTLET	BRANCH	OUTLET	BRANCH	OUTLET
		WC-1 WATER CLOSET FLOOR MOUNTED FLUSH VALVE ACCESSIBLE	"KOHLER" HIGHLINE NO. K-4405, FLOOR MOUNTED, ELONGATED, SIPHON JET ACTION 1-1/2" TOP SPUD, 17-1/8" RIM HEIGHT, 1.28 GPF	"SLOAN" ROYAL 111 HET 1.28, ADA COMPLIANT, 1.28 GPF (MANUAL)	SEAT: "CHURCH" MODEL 255SSC OR "BEMIS" MODEL 3155SSCT. PROVIDE WITH SELF-SUSTAINING CONCEALED CHECK HINGES. ONE PIECE STAINLESS STEEL POST HINGES, WHITE COLOR.	MOUNT AT HEIGHT INDICATED ON ARCHITECTURAL DRAWINGS. WHERE USED FOR CBC ACCESSIBLE WATER CLOSETS, THE FLUSH VALVE HANDLE SHALL BE MOUNTED ON THE WIDE SIDE OF THE WATER CLOSET ENCLOSURE.	2"	4"	4"	1-1/4"	1"	--	--
		L-1 LAVATORY WALL MOUNTED HOT AND COLD WATER STD/ACCESSIBLE	"KOHLER" KINGSTON NO. K-2005 WALL HUNG, VITREOUS CHINA WITH CONTOURED BACK AND SIDE SPLASH SHIELDS, FRONT OVERFLOW, CONCEALED ARM RECESS, 4" CENTERS, 21-1/4" x 18-1/8" D SHAPED BOWL.	"CHICAGO" 3300-ABCP FAUCET, PUSH LEVER WITH AERATOR WITH 0.5 GPM FLOW RATE. WITH VANDAL RESISTANT ECONO-FLO SPRAY OUTLET. WITH IPS CONNECTIONS, ADA COMPLIANT. SET MAXIMUM WATER TEMPERATURE STOP TO RESTRICT WATER TEMPERATURE TO 110° F.	ADA COMPLIANT. LAVATORY GRID DRAIN WITH 1-1/4" OFFSET TAILPIECE, INTEGRAL PERFORATED GRID NO. 7723.018, CHROME FINISH. MOUNT P-TRAP FLUSH TO WALL. CARRIER: "J R SMITH" 0700 OR EQUAL	MOUNT AT HEIGHT INDICATED ON ARCHITECTURAL DRAWINGS. PROVIDE CONCEALED ARMS AND FLOOR SUPPORT, WITH FEET OF SUPPORT SECURELY ANCHORED TO FLOOR. IN ADDITION ANCHOR TOP OF SUPPORT TO WALL CONSTRUCTION.	1 1/2"	2"	1 1/2"	3/4"	1/2"	3/4"	1/2"
		S-1 SINK COUNTER MOUNTED HOT AND COLD WATER WORK ROOM	"ELKAY" MODEL LRADQ2219-65-BP, 19" FRONT TO BACK, 22" WIDE x 6-1/2" DEPTH OVERALL, 18 GAUGE STAINLESS STEEL, LEDGE BACK WITH SELF-RIM, PROVIDE SINGLE FAUCET HOLE. PROVIDE REAR DRAIN LOCATION. PROVIDE FACTORY ADHERED VANDAL RESISTANT BACKING PLATE AT FAUCET, AND SLOT AT FAUCET FOR VANDAL RESISTANT PINS.	"CHICAGO" ECASST MODEL 50-317(VAVVP)ABCP GOOSENECK FAUCET, 1.5 GPM VANDAL RESISTANT LAMINAR FLOW AERATOR AND RIGID FAUCET. PROVIDE VANDAL RESISTANT PIN IN FAUCET, ARRANGED TO MATE WITH SLOT IN SINK.	"ELKAY" MODEL LKAD35, OFFSET CRUMB CUP STRAINER WITH REMOVABLE BASKET AND P-TRAP. INSTALL P-TRAP FLUSH TO WALL. *ENFIELD W511 P-TRAP WITH CLEAR BASE.	FOR ACCESSIBLE SINKS "HANDY-SHIELD" MODEL 3011-2 INSULATOR PROTECTORS	1 1/2"	2"	1 1/2"	3/4"	1/2"	3/4"	1/2"
		DF-1 DRINKING FOUNTAIN WALL MOUNTED STD/ACCESSIBLE DUAL HEIGHT	"HAWKS" 1117L, STAINLESS STEEL DUAL HEIGHT, WALL MOUNTED STAINLESS STEEL BACK PANEL.	INTEGRAL	WITH P-TRAP	SUPPORT SYSTEM: MODEL 6700.4 MOUNTING PLATE AND 6800 SUPPORT CARRIER. PROVIDE MANUFACTURER'S INTERNAL SUPPORT SYSTEM. WHERE INSTALLED ON CONCRETE OR CMU WALL, PROVIDE TWO MODEL 6700 MOUNTING PLATES AND INSTALL WITH ONE PLATE ON EACH SIDE OF WALL. SET AT HEIGHT INDICATED ON ARCH DRAWINGS.	1 1/2"	2"	1 1/2"	3/4"	1/2"	-	-
		GD GARBAGE DISPOSER	DISPOSER: "IN-SINK-ERATOR" EVOLUTION ESSENTIAL, CONTINUOUS FEED, 3/4 HP, CAPACITOR START. INSTALL DISPOSER IN RIGHT HAND COMPARTMENT. PROVIDE WALL SWITCH FOR OPERATION OF DISPOSER AND PROVIDE FULL 6 YEAR PARTS AND SERVICE WARRANTY FOR DISPOSER.										
		ESH/EW EMERGENCY SHOWER EYE WASH ACCESSIBLE	"GUARDIAN" MODEL GBF1909, COMBINATION SHOWER AND EYE WASH	INTEGRAL	INTEGRAL		-	TO FD	-	1 1/4"	1 1/4"	-	-
		EW-1 EYE WASH	"HAWKS" EYEPOD MODEL 7620, EYE WASH	ATTACH TO FAUCET GOOSENECK	INTEGRAL		-	-	-	-	-	-	-
		EW-2 EYE WASH ACCESSIBLE	"BRADLEY" MODEL S19-46SEFW, DECK MOUNTED HAND HELD HOSE SPRAY WITH S27-303 DUAL-CHECK BACKFLOW PREVENTER.	INTEGRAL	INTEGRAL		-	-	-	3/4"	1/2"	-	-
		RIM REFRIGERATOR ICE MAKER	"WATER-TITE" MODEL MIB-1AB OR "GUY GRAY" MODEL SSB2AB LEAD FREE ICE MAKER HOOK-UP, WITH 1/2" FIP INLET AND 1/4" COMPRESSION OUTLET	INTEGRAL	INTEGRAL	PROVIDE STAINLESS STEEL BOX AND STAINLESS STEEL FACE PLATE.	-	-	-	1/2"	1/4"	-	-
		DW DISHWASHER	ZURN MODEL CD3P SPEEDFLEX AIR GAP FITTING IN SINK LEDGE	INTEGRAL	PROVIDE HW STOP VALVE	ROUGH-IN AND CONNECT HOT WATER AND 2" VENTED P-TRAP	-	-	-	-	-	-	1/2"
		HB HOSE BIBB	EXTERIOR WALL MOUNTED - ACORN MODEL 8121CR OR WOODFORD MODEL 24CH, OR EQUAL. ROOF MOUNTED - ACORN MODEL 8126CR OR WOODFORD MODEL RHMC-MS, OR EQUAL. ROOF MOUNTED ON PARAPET OR SIDE OF AC UNIT - ACORN MODEL 8121CR OR WOODFORD MODEL 24CH, OR EQUAL. INTERIOR WALL MOUNTED - ACORN MODEL 8121CP WOODFORD MODEL 24PC, OR EQUAL. EXTERIOR WALL MOUNT NON-FREEZE - J.R. SMITH 5609QT OR WOODFORD MODEL 27, OR EQUAL.	WITH INTEGRAL VACUUM BREAKER PROTECTED. CARTRIDGE OPERATED HOSE VALVE WITH LOCK SHIELD BONNET AND REMOVABLE KEY HANDLE.			-	-	-	3/4"	3/4"	-	-
		TP TRAP PRIMER	MIFAB "M-500" SERIES, PRECISION PLUMBING PRODUCTS "PRIME-RITE" OR SIOUX CHIEF MANUFACTURING CO. "PRIME PERFECT"				-	-	-	1/2"	1/2"	-	-
		FD FLOOR DRAIN	GENERAL SERVICE FD - ZURN MODEL Z-415, OR EQUAL, WITH TYPE "B" STRAINER FOR EXPOSED CONCRETE AND TYPE "S" STRAINER FOR TILE FLOOR. PROVIDE BRONZE TRIM. FD IN COMPOSITION TYPE FLOORS - ZURN MODEL Z-415, OR EQUAL, WITH TYPE SL STRAINER. FD IN RESINOUS/EPOXY TYPE FLOORS - ZURN MODEL Z-415BL, OR EQUAL, NICKEL BRONZE WITH ADJUSTABLE STRAINER. FD CONNECTED TO ACID WASTE PIPING SYSTEMS - ORION MODEL FD-1, OR EQUAL, CORROSION RESISTANT FLOOR DRAIN, MANUFACTURED FROM FIRE RETARDING POLYPROPYLENE MATERIAL. PROVIDE FIBER-FILLED POLYPROPYLENE GRATE. CONNECT TRAP PRIMER TO FLOOR DRAIN CONNECTION. PROVIDE FUSION JOINT P-TRAP TO MATCH PIPING SYSTEM.				2"	2"	2"	-	-	-	-
		LS-1 LAB SINK COLD WATER	SEE SPECIFICATION SECTION 12345, SPECIALTY CASEWORK FOR NEW EPOXY SINKS. PROVIDE SLOT AT FAUCET FOR VANDAL RESISTANT PINS.	"CHICAGO" MODEL 928-369CP, LEVER OPERATED DECK-MOUNTED FAUCET IN CENTER PUNCH, WITH VACUUM BREAKER AND SERRATED NOZZLE OUTLET. PROVIDE FACTORY ADHERED VANDAL RESISTANT BACKING PLATE AT ALL FAUCETS, AND PROVIDE SLOTS AT FAUCETS FOR VANDAL RESISTANT PINS. BACKING PLATE SHALL BE 14 GAUGE, 304 STAINLESS STEEL, FORMED AS A CHANNEL.	"ENFIELD", "ORION", OR EQUAL, ACID WASTE AND LOOP VENT WITH "ENFIELD W511 P-TRAP WITH CLEAR BASE. PROVIDE JUST J-15SSW-316 STAINLESS STEEL STANDPIPE DRAIN, WITH 4 INCH STANDPIPE.	FOR ACCESSIBLE SINKS "HANDY-SHIELD" MODEL 3011-2 INSULATOR PROTECTORS	1 1/2"	2"	2"	3/4"	1/2"	-	-
		LS-2 LAB SINK HOT AND COLD WATER	SEE SPECIFICATION SECTION 12345, SPECIALTY CASEWORK FOR NEW EPOXY SINKS. PROVIDE SLOT AT FAUCET FOR VANDAL RESISTANT PINS.	"CHICAGO" MODEL 930-369CP, LEVER OPERATED DECK-MOUNTED FAUCET IN CENTER PUNCH, WITH VACUUM BREAKER AND SERRATED NOZZLE OUTLET. PROVIDE FACTORY ADHERED VANDAL RESISTANT BACKING PLATE AT ALL FAUCETS, AND PROVIDE SLOTS AT FAUCETS FOR VANDAL RESISTANT PINS. BACKING PLATE SHALL BE 14 GAUGE, 304 STAINLESS STEEL, FORMED AS A CHANNEL.	"ENFIELD", "ORION", OR EQUAL, ACID WASTE AND LOOP VENT WITH "ENFIELD W511 P-TRAP WITH CLEAR BASE. PROVIDE JUST J-15SSW-316 STAINLESS STEEL STANDPIPE DRAIN, WITH 4 INCH STANDPIPE.	FOR ACCESSIBLE SINKS "HANDY-SHIELD" MODEL 3011-2 INSULATOR PROTECTORS	1 1/2"	2"	2"	3/4"	1/2"	3/4"	1/2"
		FH FUME HOOD	FUME HOOD NOT IN PLUMBING CONTRACT ROUGH-IN WASTE, COLD WATER AND GAS MAKE FINAL CONNECTION			WASTE: ENFIELD, ORION, OR EQUAL ACID WASTE FOR HORIZONTAL WASTE AND VENT PIPING, WITH ENFIELD "S" W511 P-TRAP WITH CLEAR BASE.	1 1/2"	2"	1 1/2"	3/4"	1/2"	-	-
		GO GAS OUTLET	GAS OUTLET-"CHICAGO" MODEL 982-VR909AGVCP, WITH TURRET AND SERRATED NOZZLE.										

GENERAL NOTES:
 1. WATER SUPPLIES AND STOPS
 A. PROVIDE 85 PERCENT IPS RED BRASS PIPE, SECURELY ANCHORED TO BUILDING CONSTRUCTION, FOR EACH CONNECTION TO FAUCETS, STOPS, HOSE BIBBS, ETC. EACH FIXTURE, EXCEPT HOSE BIBBS, SHALL HAVE A STOP VALVE INSTALLED ON WATER SUPPLY LINES TO PERMIT REPAIRS WITHOUT SHUTTING OFF WATER MAINS.
 B. PROVIDE ALL WATER SUPPLIES TO FIXTURES WITH COMPRESSION SHUT-OFF STOPS WITH IPS INLETS WITH THREADED BRASS NIPPLES AT PIPE CONNECTION AND LOCK SHIELD LOOSE KEY. PROVIDE COMBINATION FIXTURES WITH COMPRESSION STOP AND IPS INLET ON EACH WATER SUPPLY FITTING. PROVIDE LOOSE KEY HANDLE FOR EACH STOP.
 C. PROVIDE 1/2 INCH RISER TUBES WITH REDUCING COUPLING FOR ALL FIXTURES, UNLESS OTHERWISE NOTED. REFER TO SPECIFICATION SECTION 15440.
 2. PIPE, PIPE OR PLUMBING FITTINGS, FIXTURES, SOLDER AND FLUX INSTALLED IN A SYSTEM PROVIDING WATER FOR HUMAN CONSUMPTION SHALL COMPLY WITH LEAD FREE REQUIREMENTS OF THE CALIFORNIA HEALTH AND SAFETY CODE SECTION 116875. PROVIDE SUBMITTAL INFORMATION FOR PRODUCTS THIRD-PARTY CERTIFIED BY AN APPROVED LABORATORY AS COMPLYING WITH CALIFORNIA HEALTH AND SAFETY CODE SECTION 116875. OF COMPLIANCE WITH THE CALIFORNIA HEALTH AND SAFETY CODE SECTION 116875. PROVIDE PRODUCT SUBMITTAL INFORMATION PROVING

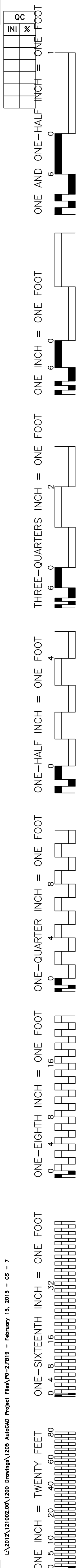

**Mt. Diablo High School
Building S - Science Lab Modernization**

2450 Grant Street
Concord, California 94520

Mt. Diablo Unified School District

MDUSD **MDUSD**

FILE NO. xx-xx
IDENTIFICATION STAMP
DIV. OF THE STATE ARCHITECT
OFFICE OF REGULATION SERVICES

APPLICATION NO.
01-
AC. FLS. 88
DATE

DIVISION OF THE STATE ARCHITECT
revision date: by:

REGISTERED PROFESSIONAL ENGINEER
22836
EXPIRES 9/30/14
MECHANICAL
STATE OF CALIFORNIA

DATE SIGNED: _____

**CAPITAL ENGINEERING
CONSULTANTS, INC.**
RANCHO CORDOVA, CALIFORNIA

CS/S/L 12/02/00
PW - DESIGN TEAM PROJECT NO.

CONSULTANT

nacht&lewis

800 G Street, Suite 100
Sacramento, CA 95811
www.nachtandlewis.com
916.329.4000

ARCHITECT

NO.	DESCRIPTION	DATE	REV'D

DATE **February 19, 2013**

JOB NO. **Y1211.00**

SHEET TITLE

Plumbing
Fixture
Specification

SHEET NO.

P0.2

SHEET ___ OF ___ TOTAL
DSA SUBMITTAL SET

ONE INCH = TWENTY FEET
 ONE-SIXTEENTH INCH = ONE FOOT
 ONE-EIGHTH INCH = ONE FOOT
 ONE-FOURTH INCH = ONE FOOT
 ONE-HALF INCH = ONE FOOT
 THREE-QUARTERS INCH = ONE FOOT
 ONE INCH = ONE FOOT
 ONE AND ONE-HALF INCH = ONE FOOT

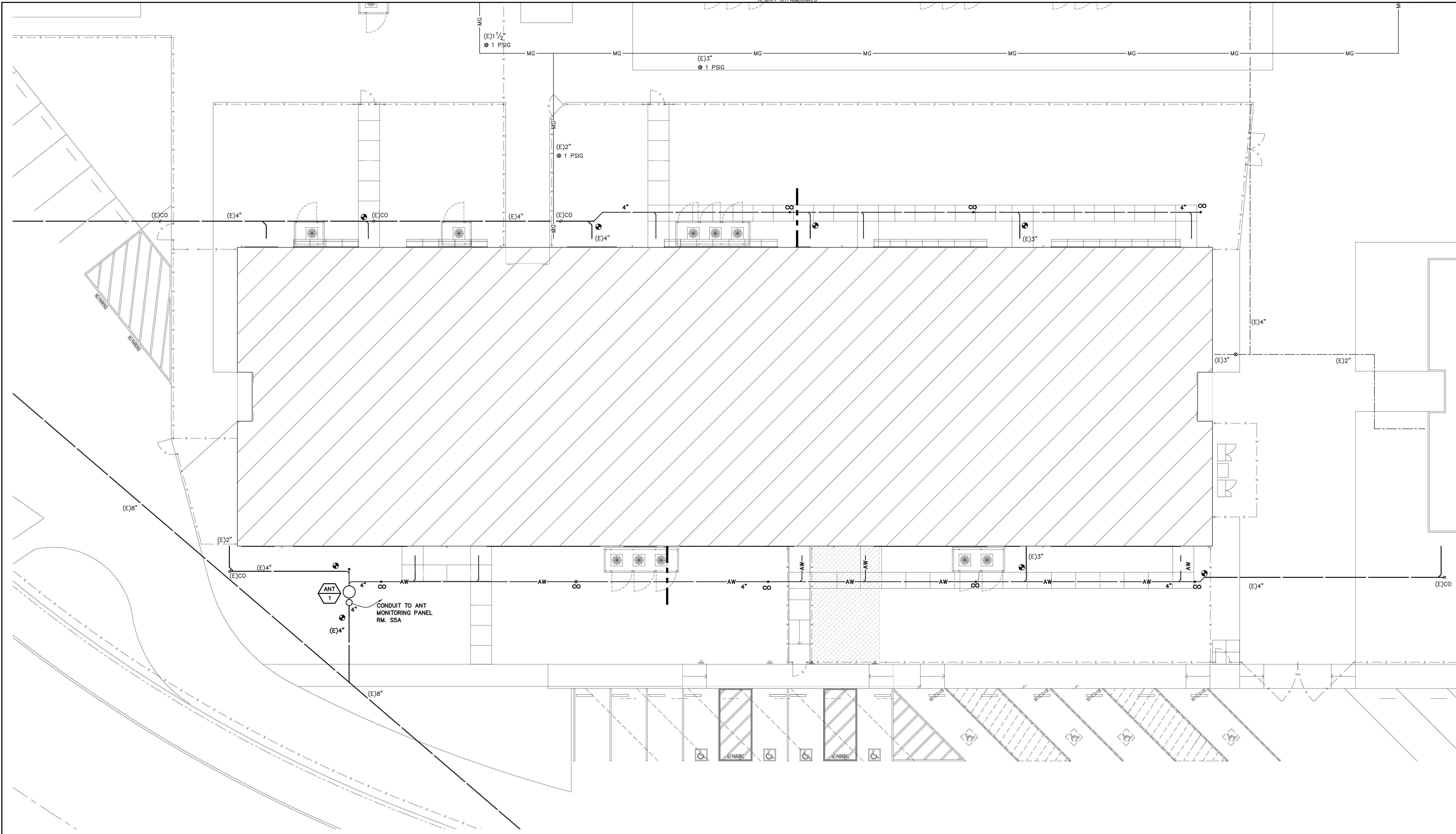

Plumbing Site Plan
 SCALE : 1" = 10'-0"
1
P1.1

MDUSD
 Mt. Diablo High School
 Building S - Science Lab Modernization
 2450 Grant Street
 Concord, California 94520
 Mt. Diablo Unified School District



FILE NO. xx-xx
 IDENTIFICATION STAMP
 DIV. OF THE STATE ARCHITECT
 OFFICE OF REGULATION SERVICES
 APPLICATION NO. 01-
 AC. FLS. SS
 DATE

DIVISION OF THE STATE ARCHITECT
 revision date: by:



DATE SIGNED:
CAPITAL ENGINEERING CONSULTANTS, INC.
 RANCHO CORDOVA, CALIFORNIA
 CS/SJL 12/02/00
 PM - DESIGN TEAM PROJECT NO.

CONSULTANT

nacht&lewis
 800 G Street, Suite 100
 Sacramento, CA 95811
 www.nachtlewis.com
 916.329.4000

ARCHITECT

REVISIONS			
NO.	DESCRIPTION	DATE	REV'D

DATE February 19, 2013
 JOB NO. Y1211.00
 SHEET TITLE

Plumbing Site Plan

SHEET NO.
P1.1

SHEET ___ OF ___ TOTAL
 DSA SUBMITTAL SET

ONE AND ONE-HALF INCH = ONE FOOT
ONE INCH = ONE FOOT
THREE-QUARTERS INCH = ONE FOOT
ONE-HALF INCH = ONE FOOT
ONE-QUARTER INCH = ONE FOOT
ONE-EIGHTH INCH = ONE FOOT
ONE-SIXTEENTH INCH = ONE FOOT
ONE INCH = TWENTY FEET

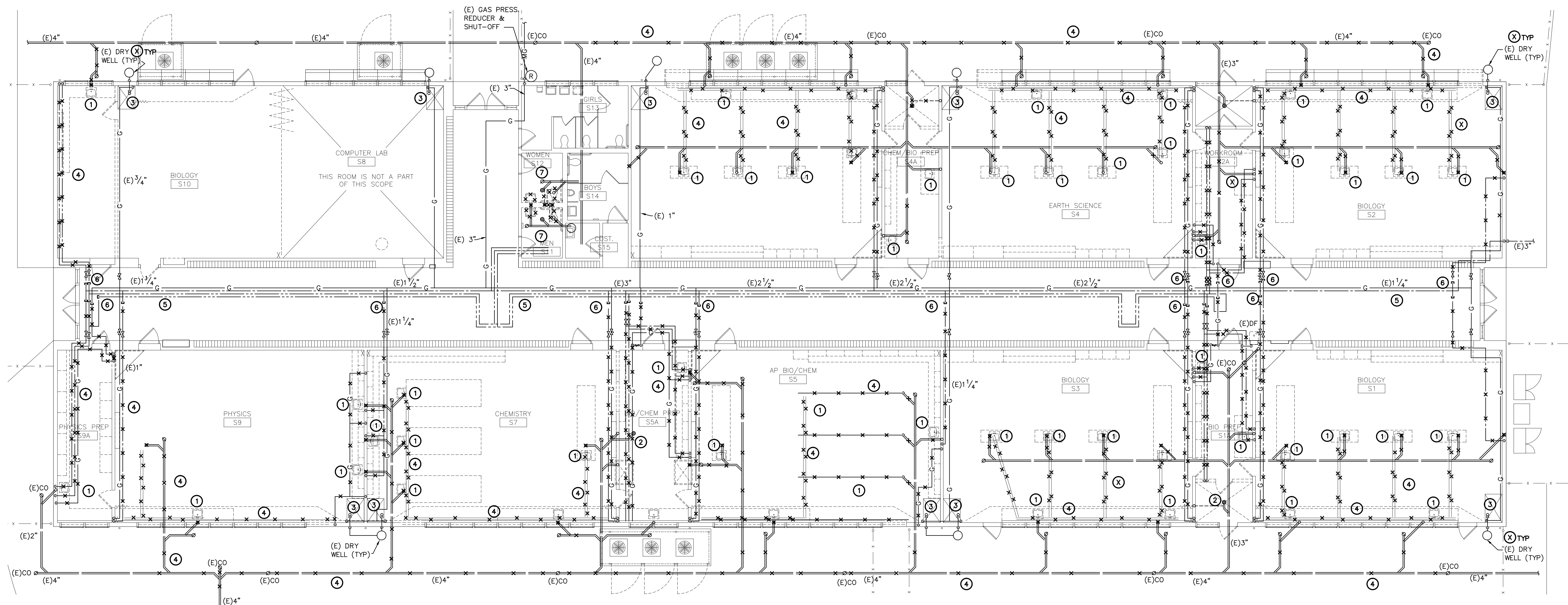

Building - Plumbing Demolition Floor Plan
SCALE : 1/8" = 1'-0"

1
P2.0

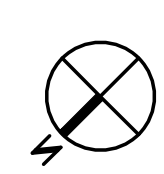

DEMOLITION SHEET NOTES

- ① EXISTING SINK TO BE REMOVED.
- ② EXISTING FLOOR DRAIN TO BE REMOVED.
- ③ EXISTING GAS TO FURNACE UNIT TO REMAIN.
- ④ EXISTING PIPING TO BE REMOVED IF EXPOSED, ABANDONED IF CONCEALED.
- ⑤ EXISTING PIPING TO REMAIN.
- ⑥ EXISTING PIPING TO BE CAPPED OFF.
- ⑦ EXISTING FIXTURES TO BE REMOVED. REMOVE UNUSED PIPING AND CAP BEHIND ARCHITECTURAL FINISHES.

DEMOLITION GENERAL NOTES

- 1. UNUSED PIPING IN CONCEALED SPACES MAY BE ABANDONED IN PLACE. CAP BEHIND ARCHITECTURAL SURFACES AS NECESSARY.
- 2. WHERE UNUSED PIPING IS EXPOSED, REMOVE AND CAP UNUSED PIPING BEHIND ARCHITECTURAL SURFACES AS NECESSARY.

Mt. Diablo High School
Building S - Science Lab Modernization
2450 Grant Street
Concord, California 94520
Mt. Diablo Unified School District



FILE NO. xx-xx
IDENTIFICATION STAMP
DIV. OF THE STATE ARCHITECT
OFFICE OF REGULATION SERVICES
APPLICATION NO. 01-
AC. FLS. SS
DATE

DIVISION OF THE STATE ARCHITECT
revision date: by:



CAPITAL ENGINEERING CONSULTANTS, INC.
RANCHO CORDOVA, CALIFORNIA
CS/S/L PROJECT NO. 12002.00

CONSULTANT

nacht&lewis
800 G Street, Suite 100
Sacramento, CA 95811
www.nachtandlewis.com
916.329.4000

ARCHITECT

REVISIONS			
NO.	DESCRIPTION	DATE	REV'D

DATE **February 19, 2013**
JOB NO. **Y1211.00**
SHEET TITLE

Building Plumbing Demolition Plan

SHEET NO. **P2.0**

SHEET OF TOTAL
DSA SUBMITTAL SET

ONE INCH = TWENTY FEET
 ONE-SIXTEENTH INCH = ONE FOOT
 ONE-EIGHTH INCH = ONE FOOT
 ONE-FOURTH INCH = ONE FOOT
 ONE-HALF INCH = ONE FOOT
 THREE-QUARTERS INCH = ONE FOOT
 ONE INCH = ONE FOOT
 ONE AND ONE-HALF INCH = ONE FOOT

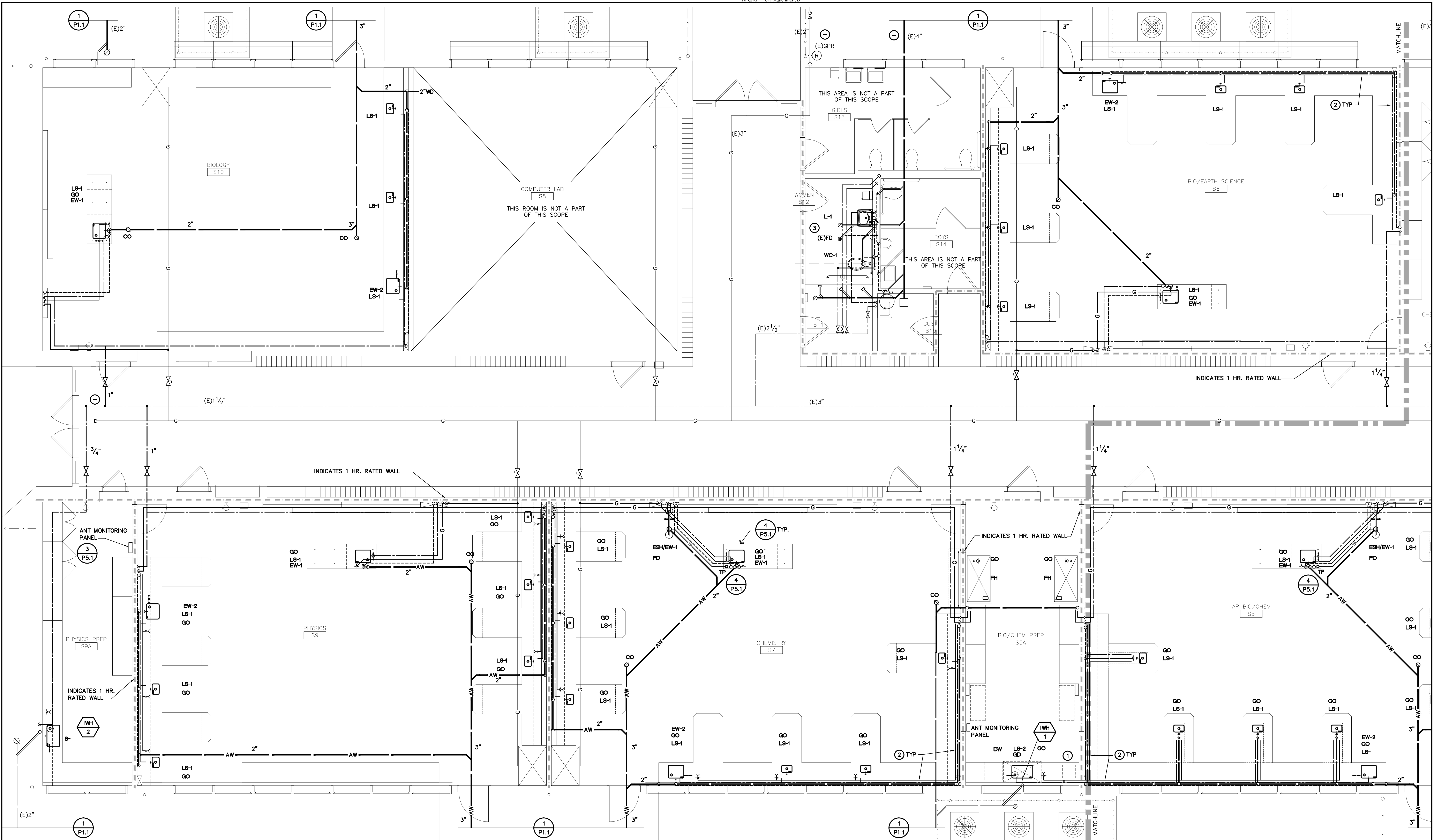

Building - Plumbing Floor Plan
 SCALE : 1/8" = 1'-0"
1
P3.0

SHEET NOTES

- ① DEIONIZER BY OWNER
- ② CAREFULLY COORDINATE WITH ARCHITECT PIPING IN BACK OF CABINET CHASE AND IN WALLS.
- ③ EXTEND EXISTING PIPING TO NEW FIXTURES AS REQUIRED.

GENERAL NOTES

- 1. CONTRACTOR TO PROVIDE MOST EFFICIENT LAYOUT POSSIBLE FOR THE UNDER SLAB WORK TO MINIMIZE SAW CUTTING.

KEYPLAN:

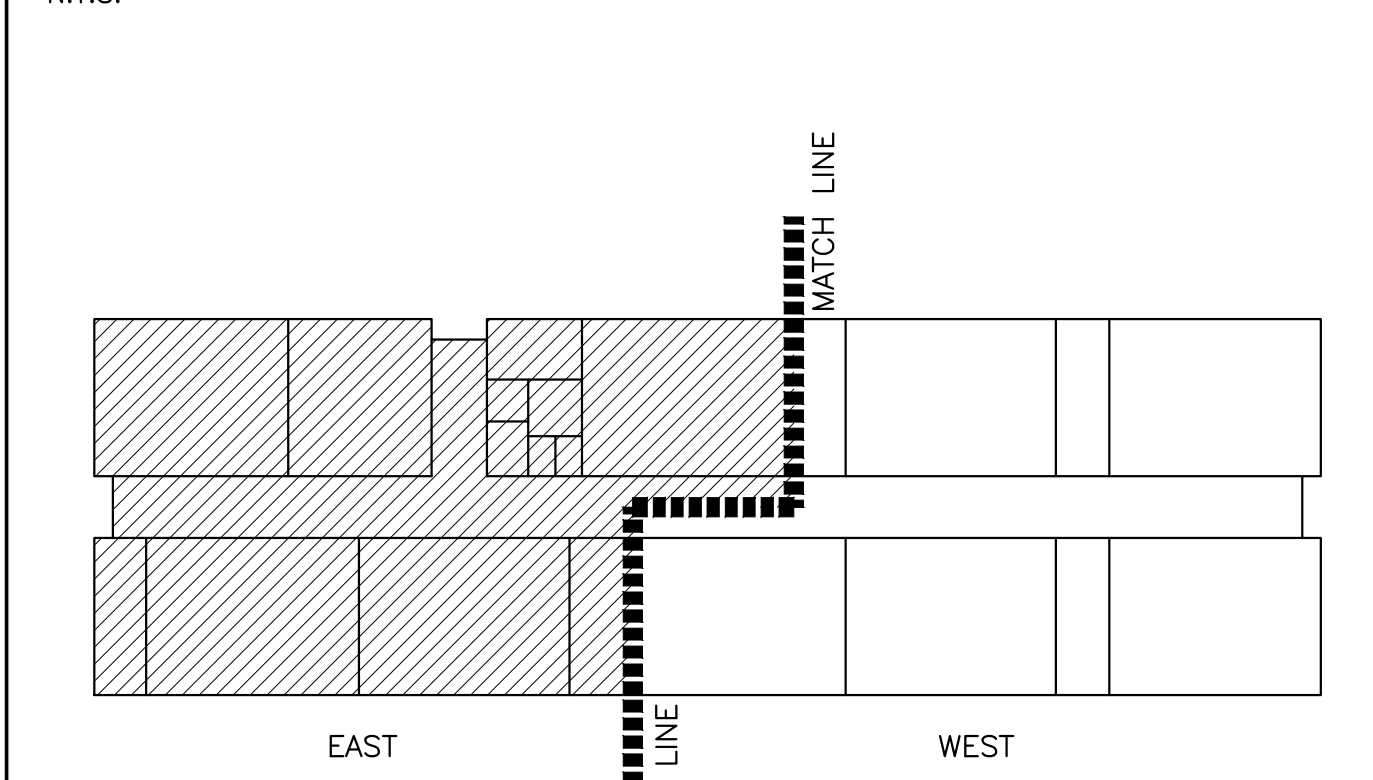

Mt. Diablo High School
Building S - Science Lab Modernization
 2450 Grant Street
 Concord, California 94520
Mt. Diablo Unified School District

MDUSD

FILE NO. xx-xx
 IDENTIFICATION STAMP
 DIV. OF THE STATE ARCHITECT
 OFFICE OF REGULATION SERVICES
 APPLICATION NO. 01-
 AC. FLS. SS
 DATE

DIVISION OF THE STATE ARCHITECT
 revision date: by:

REGISTERED PROFESSIONAL ENGINEER
 THOMAS A. DAULTON
 No. 22836
 EXPIRES 2/28/14
 MECHANICAL
 STATE OF CALIFORNIA
 DATE SIGNED:

CAPITAL ENGINEERING CONSULTANTS, INC.
 RANCHO CORDOVA, CALIFORNIA
 CS/SL 12002.00 PROJECT NO.
 PM - DESIGN TEAM

CONSULTANT

nacht&lewis
 800 G Street, Suite 100
 Sacramento, CA 95811
 www.nachtandlewis.com
 916.329.4000

ARCHITECT
REVISIONS

NO.	DESCRIPTION	DATE	REV'D

 DATE February 19, 2013
 JOB NO. Y1211.00
 SHEET TITLE
Building Plumbing Plan
 SHEET NO.
P3.0
 SHEET ___ OF ___ TOTAL
DSA SUBMITTAL SET

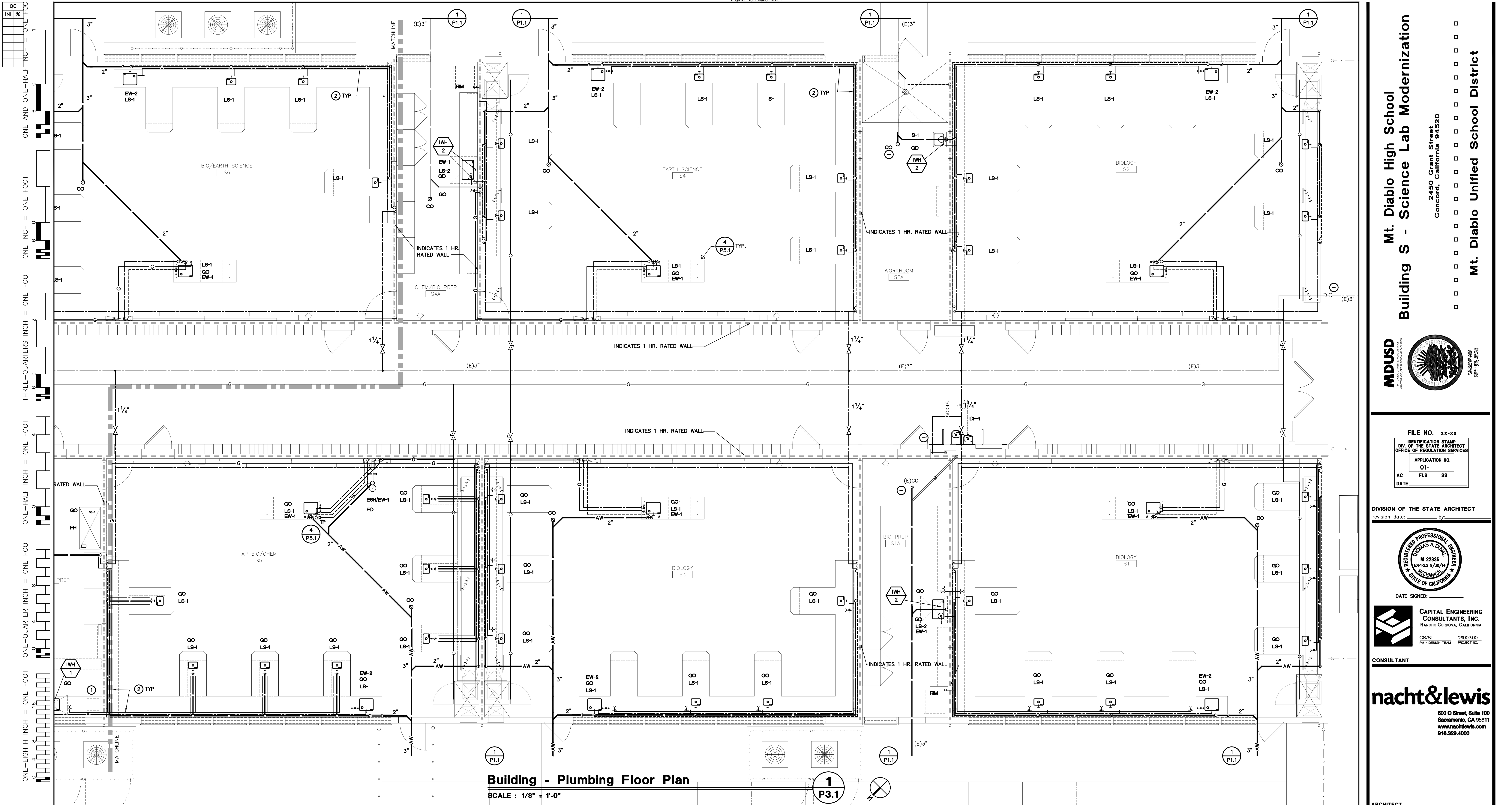

Building - Plumbing Floor Plan

SCALE : 1/8" = 1'-0"

1
P3.1

SHEET NOTES

- ① DEIONIZER BY OWNER
- ② CAREFULLY COORDINATE WITH ARCHITECT PIPING IN BACK OF CABINET CHASE AND IN WALLS.

GENERAL NOTES

1. CONTRACTOR TO PROVIDE MOST EFFICIENT LAYOUT POSSIBLE FOR THE UNDER SLAB WORK TO MINIMIZE SAW CUTTING.

KEYPLAN:

N.T.S.

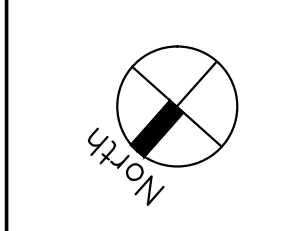
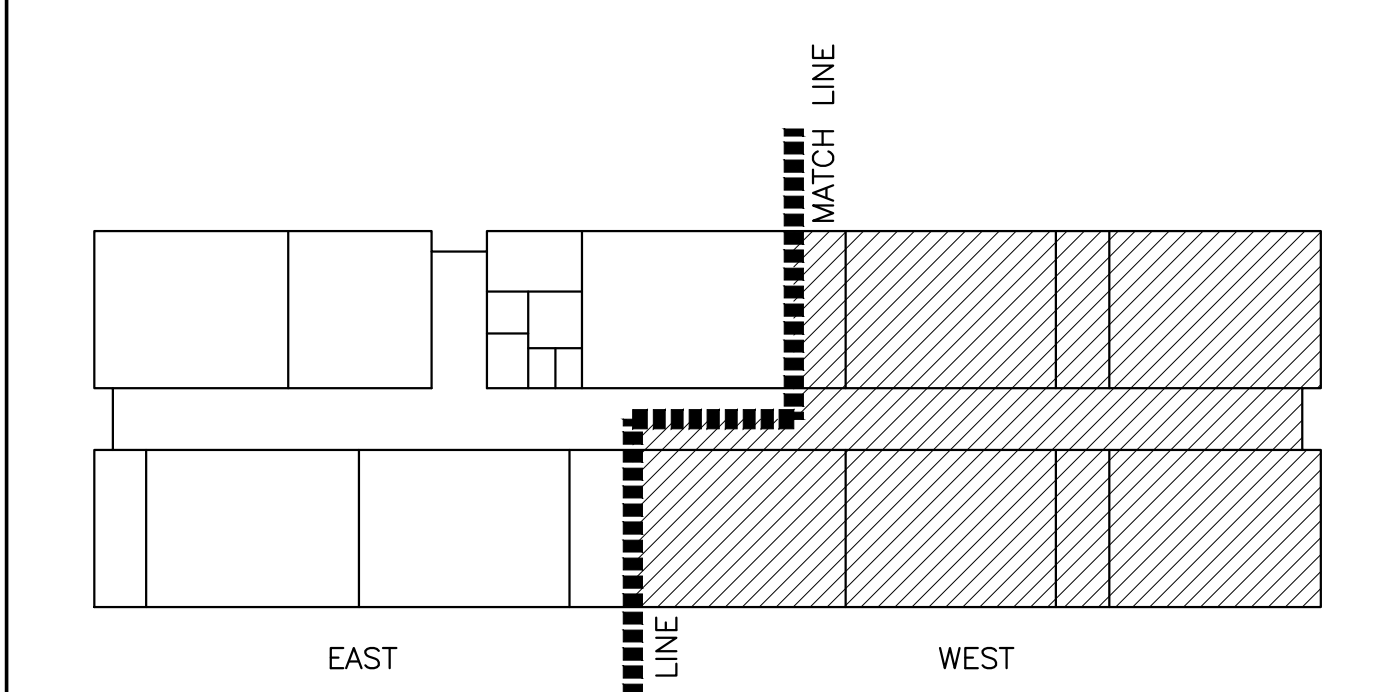

MDUSD
 Mt. Diablo High School
 Building S - Science Lab Modernization
 2450 Grant Street
 Concord, California 94520
Mt. Diablo Unified School District



FILE NO. xx-xx
 IDENTIFICATION STAMP
 DIV. OF THE STATE ARCHITECT
 OFFICE OF REGULATION SERVICES
 APPLICATION NO. 01-
 AC. FLS. 88
 DATE

DIVISION OF THE STATE ARCHITECT
 revision date: by:



DATE SIGNED: _____
CAPITAL ENGINEERING CONSULTANTS, INC.
 RANCHO CORDOVA, CALIFORNIA
 CS/S/L 12/02/00 PROJECT NO.

CONSULTANT

nacht&lewis
 800 G Street, Suite 100
 Sacramento, CA 95811
 www.nachtandlewis.com
 916.329.4000

ARCHITECT

NO.	DESCRIPTION	DATE	REV'D

DATE February 19, 2013
 JOB NO. Y1211.00
 SHEET TITLE

Building Plumbing Plan

SHEET NO.

P3.1

SHEET ___ OF ___ TOTAL
 DSA SUBMITTAL SET

ONE AND ONE-HALF INCH = ONE FOOT
 ONE INCH = ONE FOOT
 THREE-QUARTERS INCH = ONE FOOT
 ONE-HALF INCH = ONE FOOT
 ONE-QUARTER INCH = ONE FOOT
 ONE-EIGHTH INCH = ONE FOOT
 ONE-SIXTEENTH INCH = ONE FOOT
 ONE INCH = TWENTY FEET

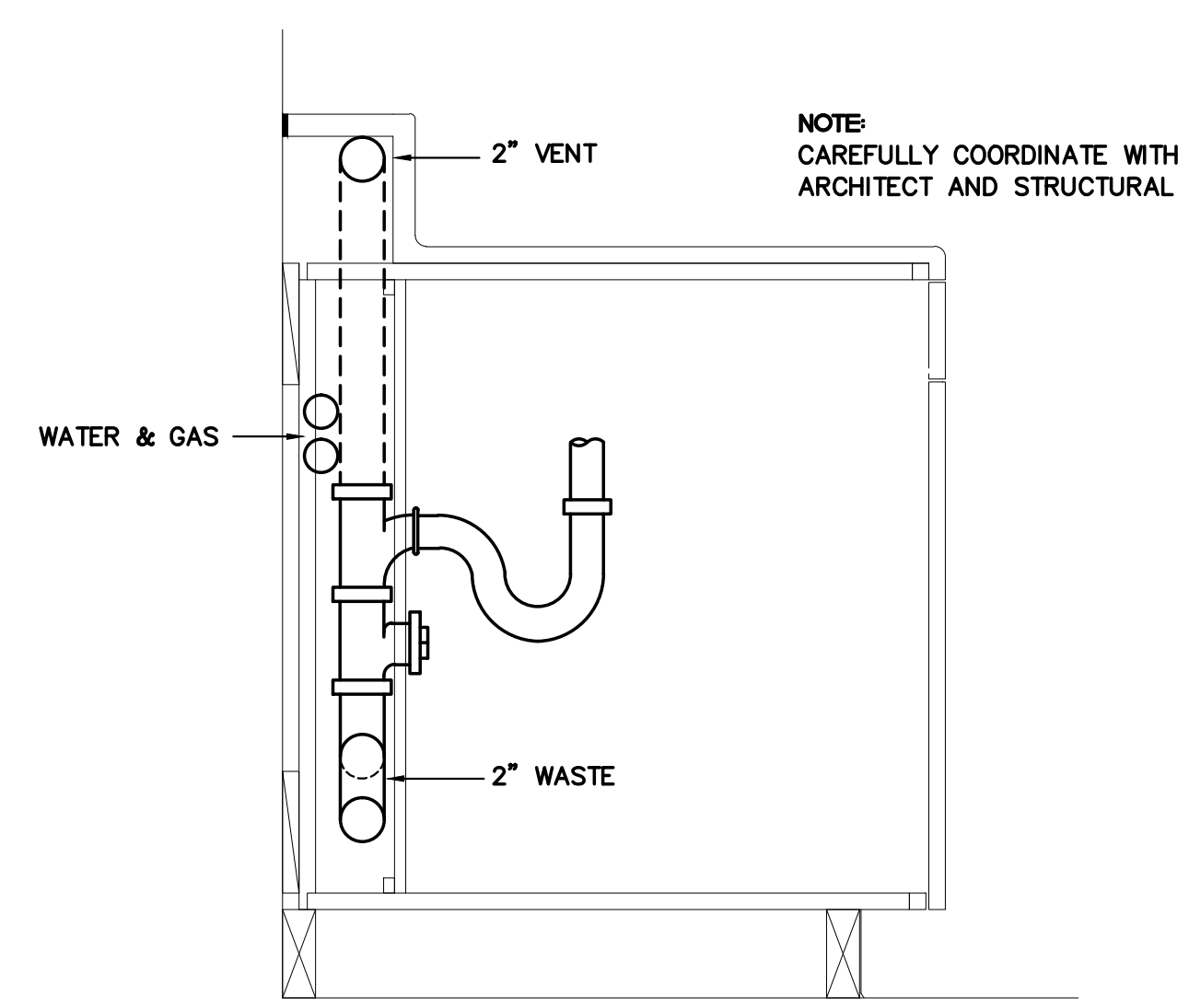

9 P5.1
PIPING BEHIND CABINETS
 SCALE : 1" = 1'-0"

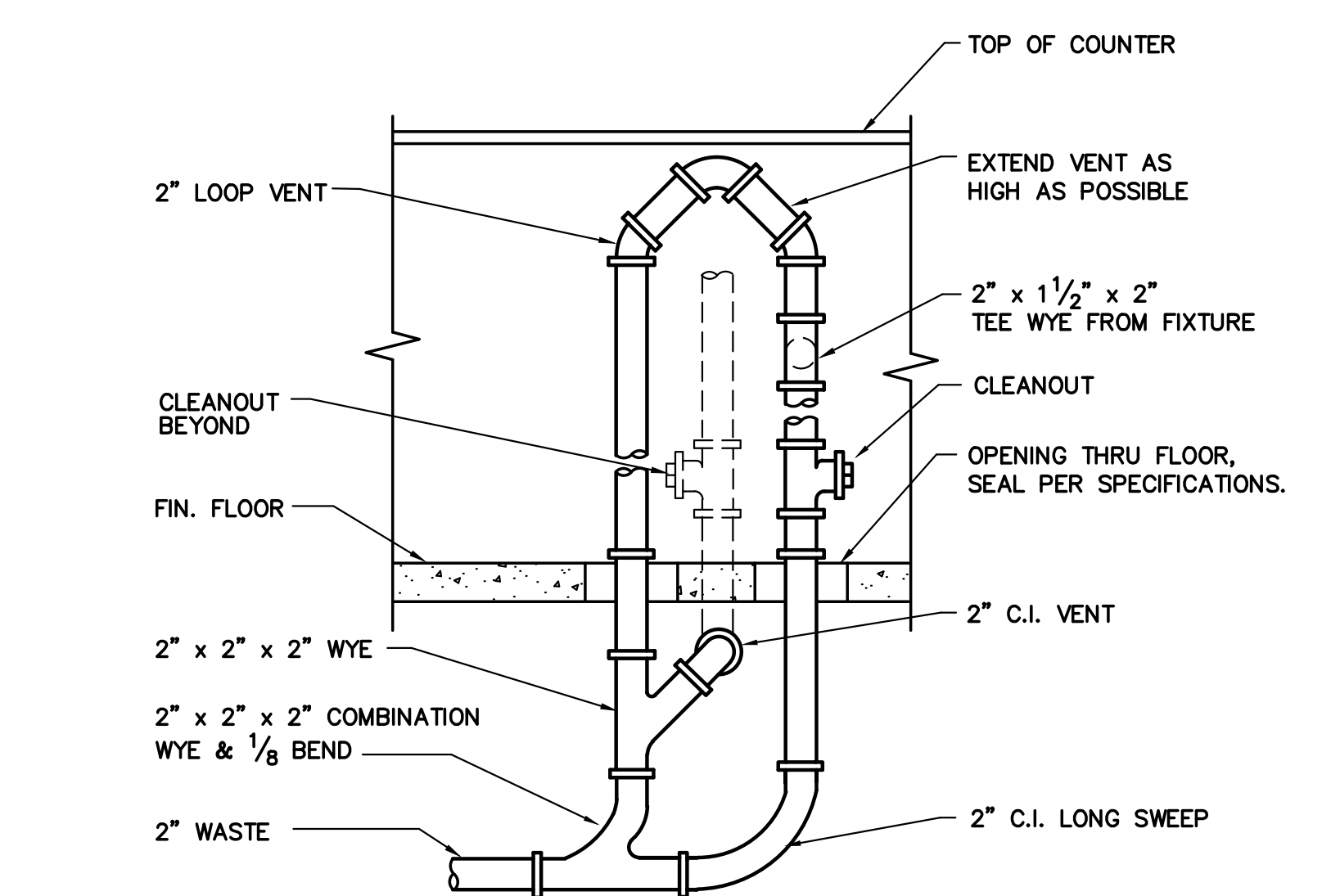

5 P5.1
ISLAND VENT
 SCALE : NONE

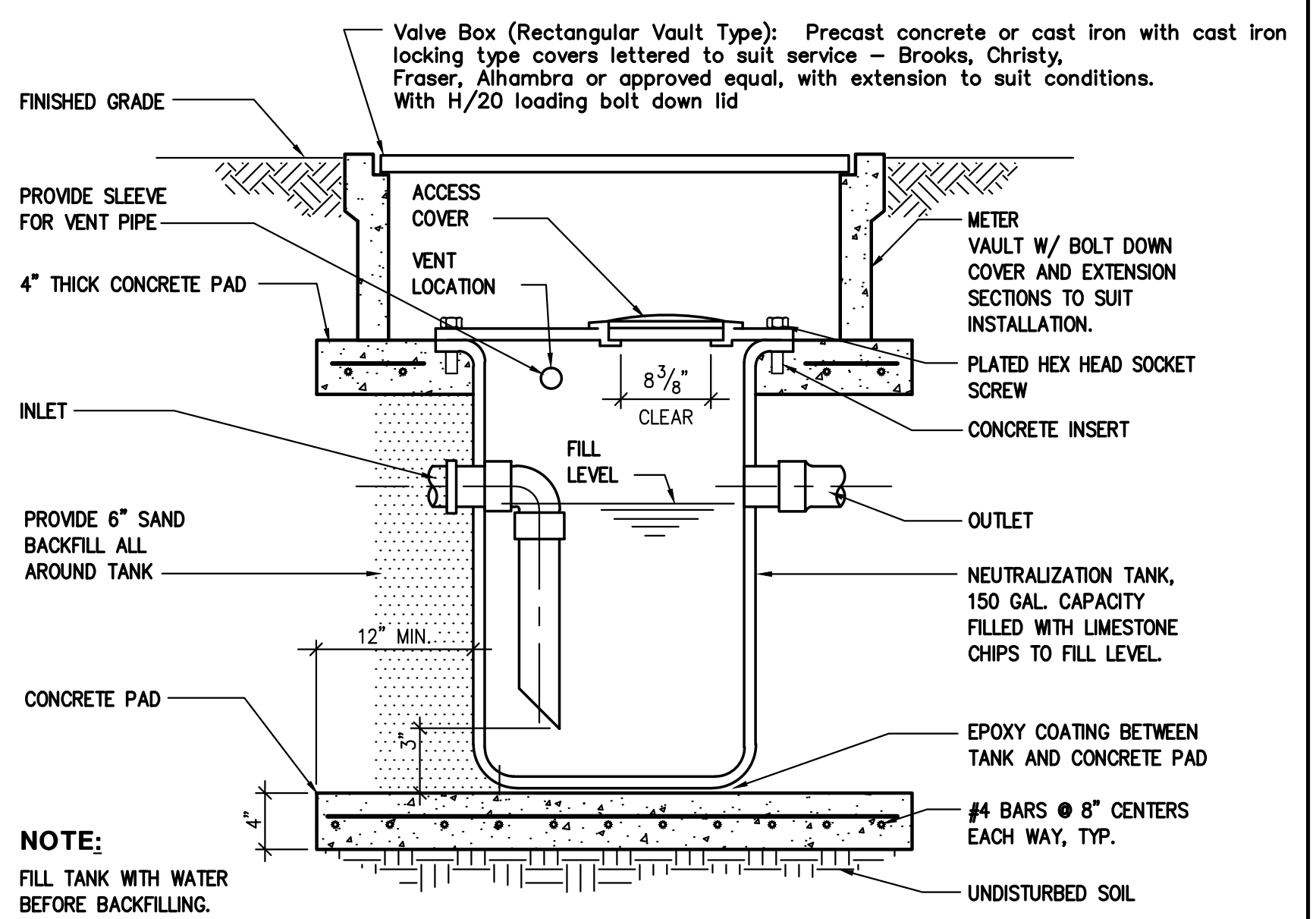

1 P5.1
ACID NEUTRALIZATION TANK (ANT)
 SCALE : NONE

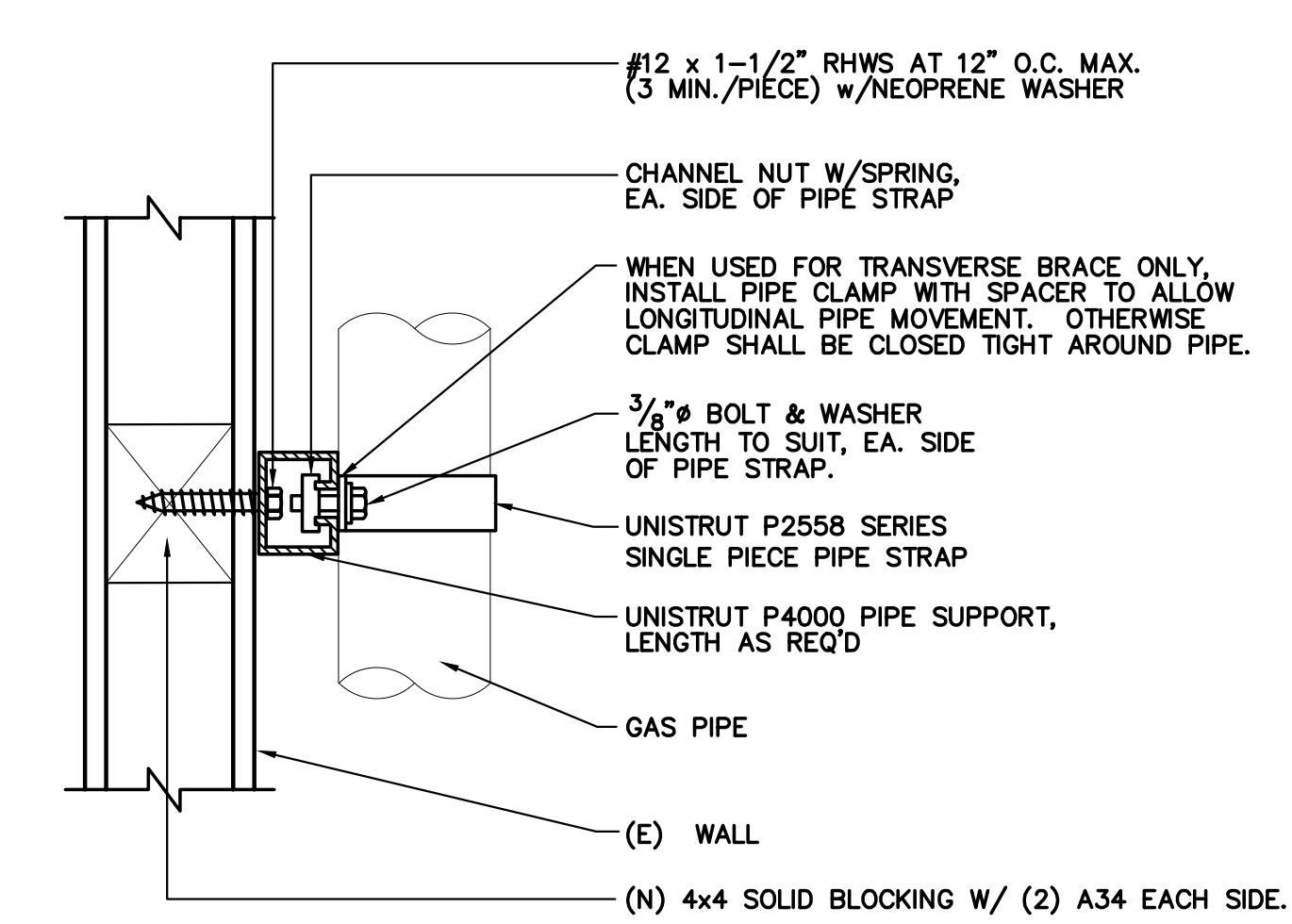

10 P5.1
INTERIOR PIPE ON WALL SUPPORT DETAIL
 SCALE : NONE

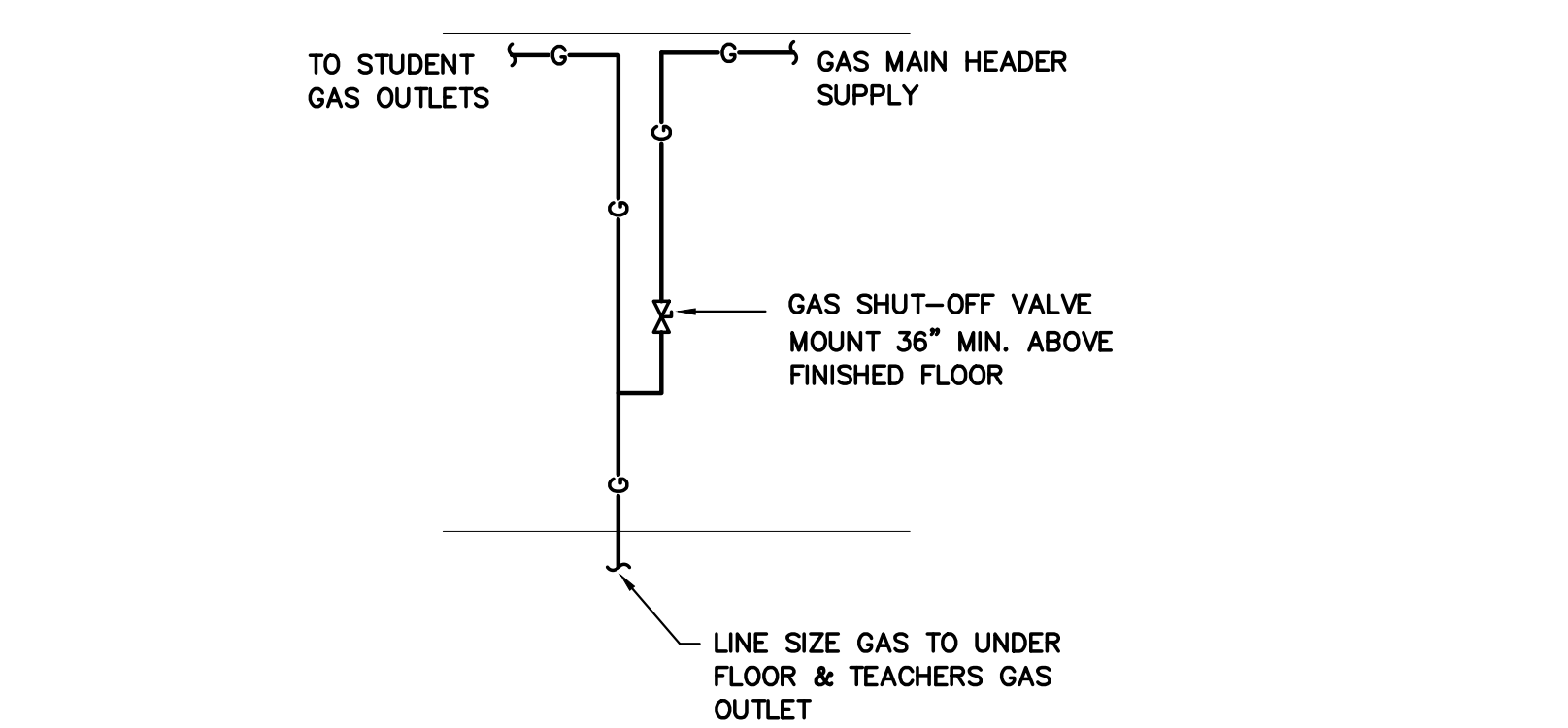

6 P5.1
GAS SHUT-OFF VALVE BOX DETAIL
 SCALE : NONE

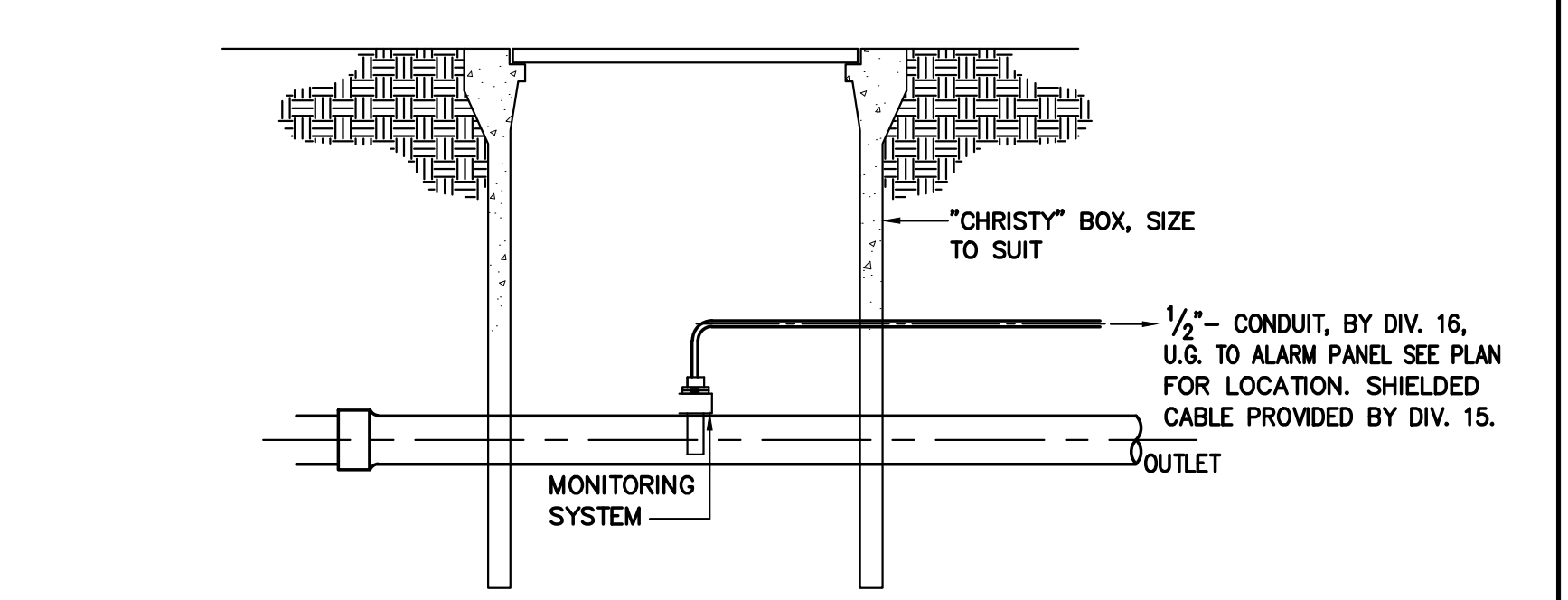

2 P5.1
ANT MONITORING SYSTEM
 SCALE : NONE

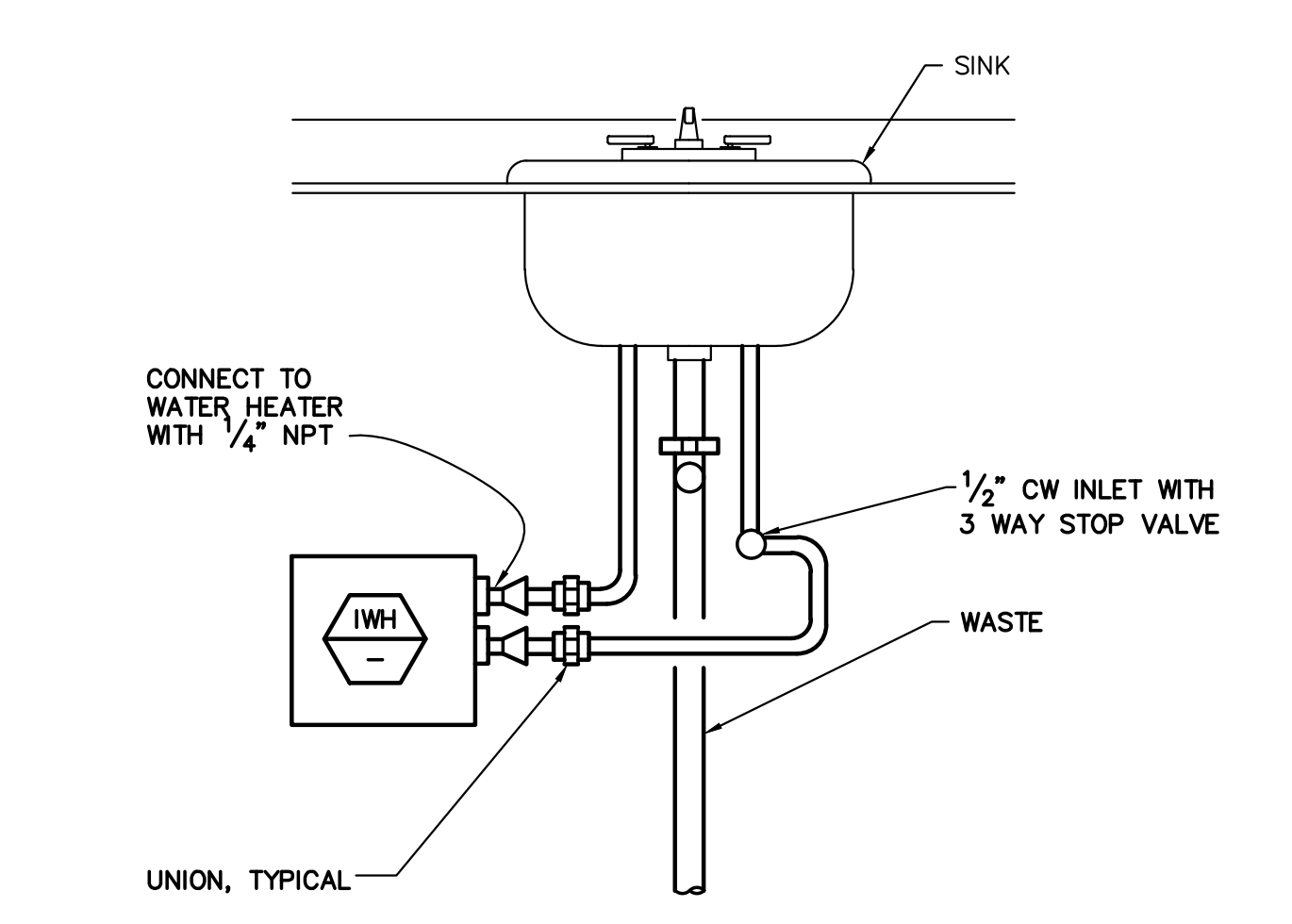

11 P5.1
INSTANTANEOUS WATER HEATER
 SCALE : NONE

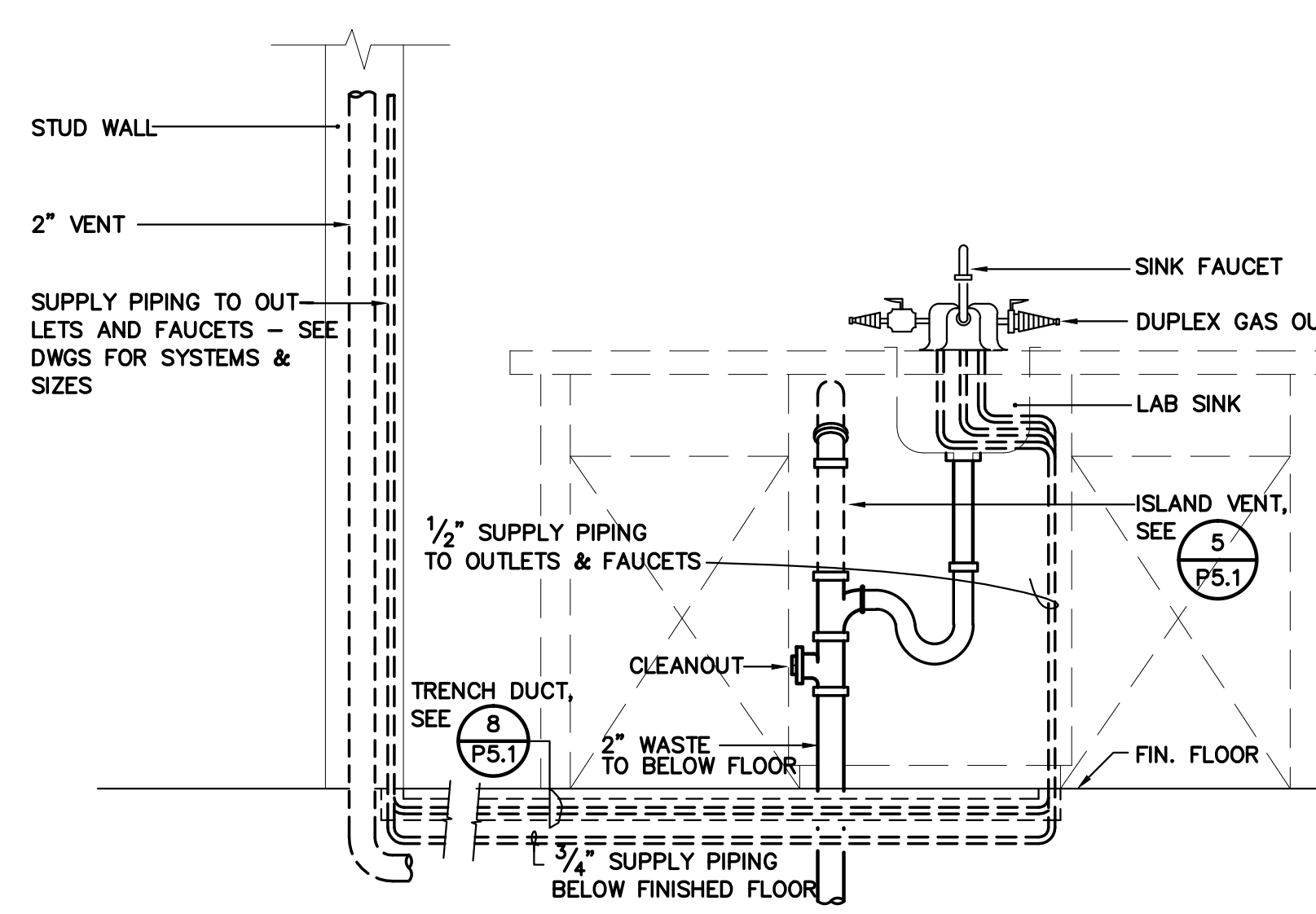

7 P5.1
TYPICAL ISLAND LAB SINK DETAIL
 SCALE : 1" = 1'-0"

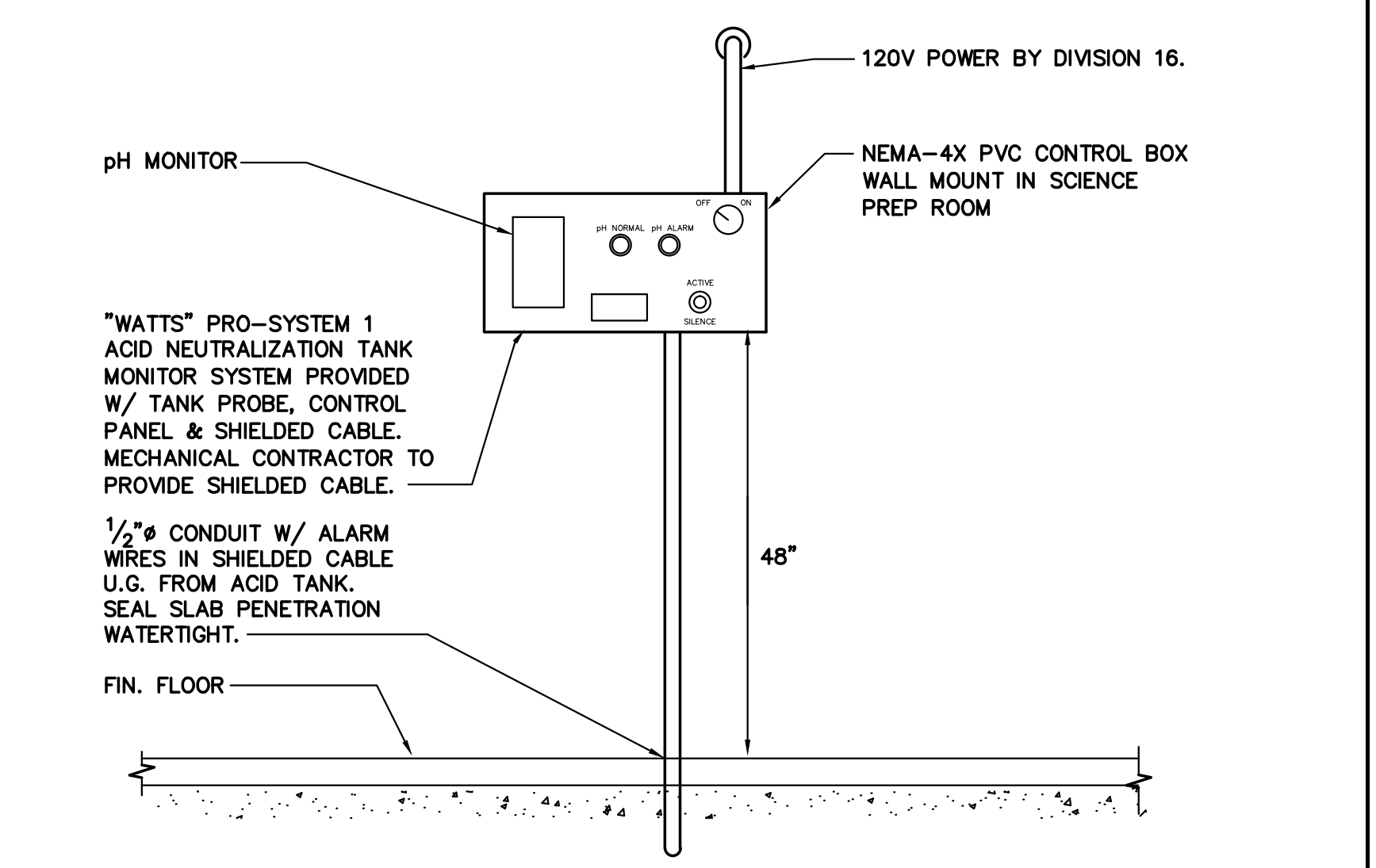

3 P5.1
ANT MONITORING PANEL
 SCALE : NONE

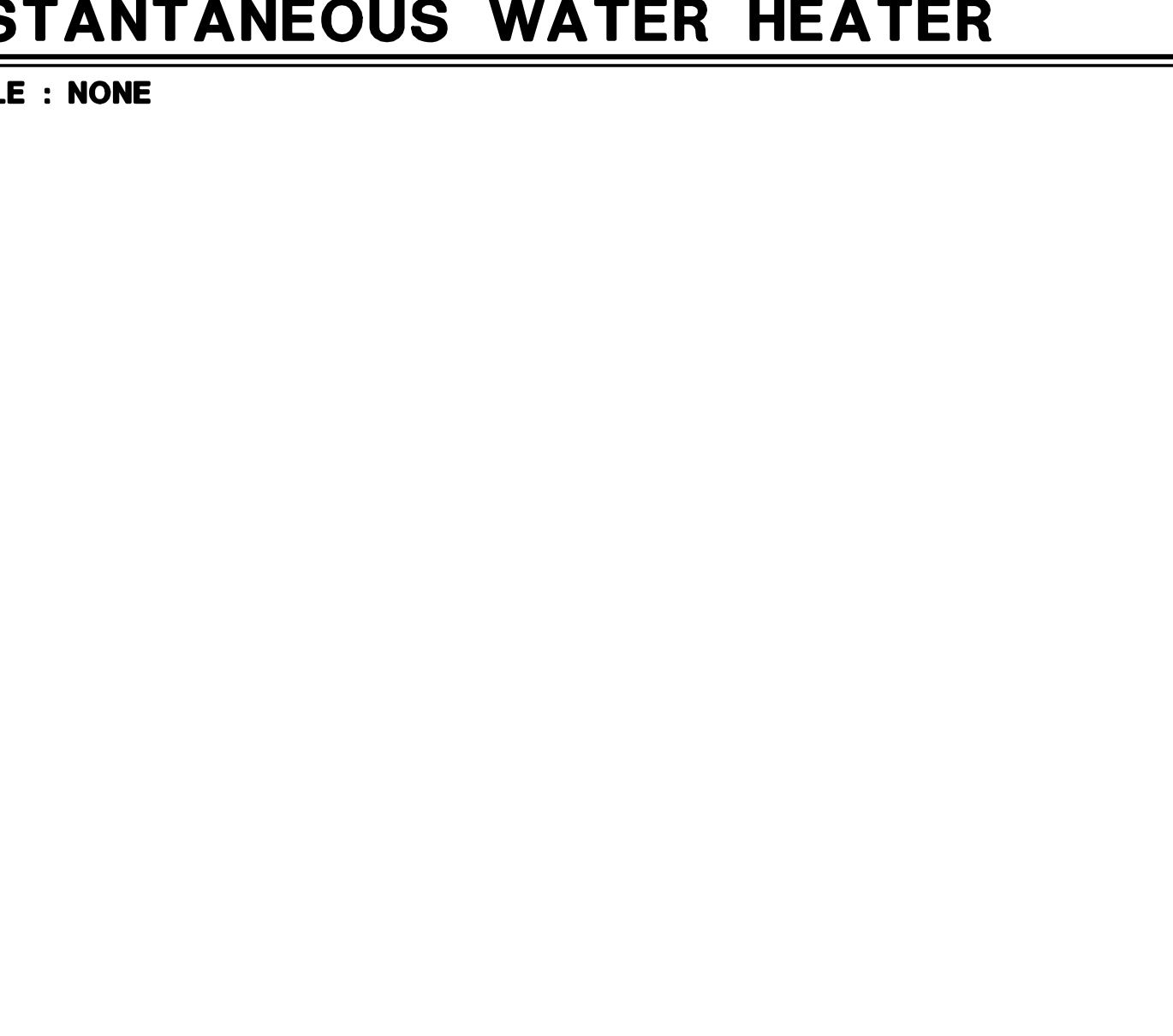

8 P5.1
GAS PIPING TRENCH DETAIL
 SCALE : NONE

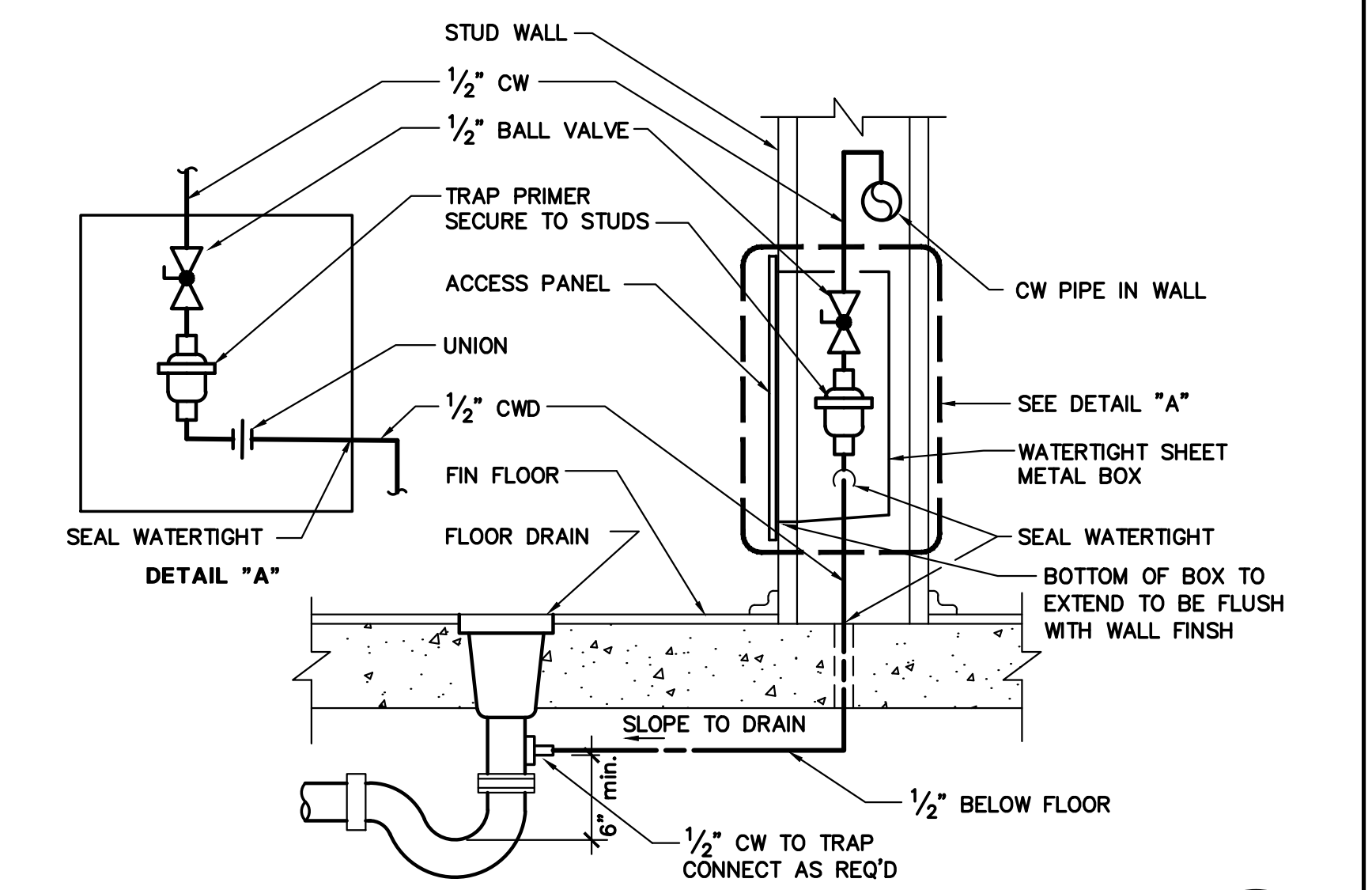

4 P5.1
TRAP PRIMER TO FLOOR DRAIN
 SCALE : NONE

Mt. Diablo High School
Building S - Science Lab Modernization
 2450 Grant Street
 Concord, California 94520
Mt. Diablo Unified School District



FILE NO. xx-xx
 IDENTIFICATION STAMP
 DIV. OF THE STATE ARCHITECT
 OFFICE OF REGULATION SERVICES
 APPLICATION NO. 01-
 AC. FLS. SS
 DATE

DIVISION OF THE STATE ARCHITECT
 revision date: by:

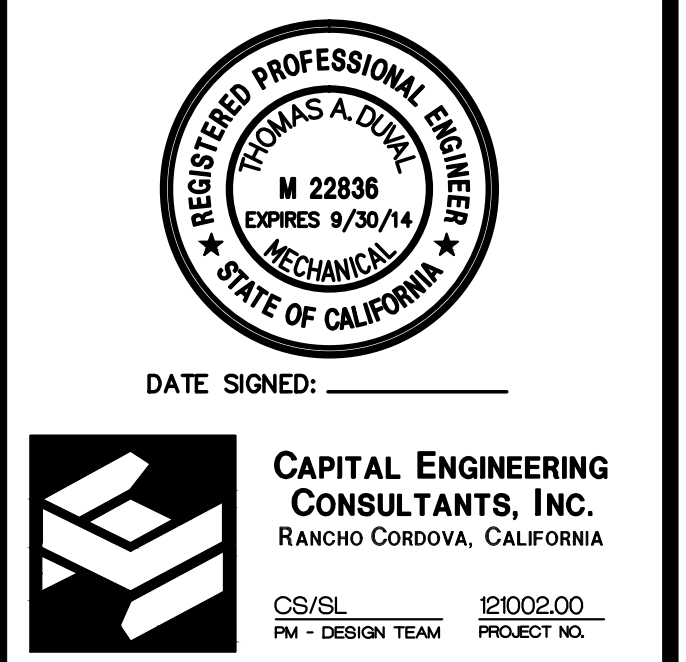

CAPITAL ENGINEERING CONSULTANTS, INC.
 RANCHO CORDOVA, CALIFORNIA
 CS/S/L PROJECT NO. 121002.00

nacht&lewis
 800 G Street, Suite 100
 Sacramento, CA 95811
 www.nachtandlewis.com
 916.329.4000

ARCHITECT

REVISIONS			
NO.	DESCRIPTION	DATE	REV'D

DATE February 19, 2013
 JOB NO. Y1211.00
 SHEET TITLE

Plumbing Details

SHEET NO. **P5.1**

SHEET ___ OF ___ TOTAL
 DSA SUBMITTAL SET

FIXTURE SCHEDULE							
SYM	MANUFACTURER & CATALOG NUMBER	LAMPS	MOUNTING	REMARKS	WEIGHT (LBS)	WATTS	CEC DEFAULT
A	FINELITE 516-DCC-8-278-8C-11K-120-AC-FE	4-F32T8	SUSPENDED 18" BELOW CEILING			114	YES
X	EVENLITE TELECOM-R-U-K-80-HL	LED	WALL ABOVE DOOR	90 MIN. BATTERIES			

ABBREVIATIONS & DESIGNATIONS

- AB ABOVE COUNTER HEIGHT
- AV AUDIO / VIDEO
- CCTV CLOSED CIRCUIT TELEVISION
- CLOCK & PROGRAM TERMINAL CABINET
- AFB ABOVE FINISHED FLOOR
- BMS BUILDING MANAGEMENT SYSTEM
- BTR IT BUILDING TELECOM ROOM
- CATV CABLE TELEVISION
- CCTV CLOSED CIRCUIT TELEVISION
- CLOCK & PROGRAM TERMINAL CABINET
- CR CRITICAL EMERGENCY BRANCH
- D DEPTH
- DIA DIAMETER
- (E) EXISTING
- EMERGENCY EMERGENCY
- EF EXHAUST FAN
- EMS ENERGY MANAGEMENT SYSTEM
- EPO EMERGENCY POWER OFF
- EQ EQUIPMENT EMERGENCY BRANCH
- FA FIRE ALARM
- FAAP FIRE ALARM REMOTE ANNUNCIATOR PANEL
- FABP FIRE ALARM SIGNAL BOOSTER PANEL
- FACP FIRE ALARM CONTROL PANEL
- FATC FIRE ALARM TERMINAL CABINET
- FCI FIRE ALARM CABINET DESIGNATION AS NOTED
- FO FIBER OPTIC
- GFCI GROUND FAULT CIRCUIT INTERRUPTER
- GFI GROUND FAULT INTERRUPTER
- GND GROUND
- H HEIGHT
- HVAC HEATING, VENTILATING, AIR CONDITIONING EQUIPMENT
- IAP INTRUSION ALARM PANEL
- IDF INTERMEDIATE DISTRIBUTION FRAME
- IDF INTERMEDIATE DISTRIBUTION FRAME, DESIGNATION AS NOTED
- IG ISOLATED GROUND
- LCP LIGHTING CONTROL PANEL
- LS LIFE SAFETY EMERGENCY BRANCH
- MDF MAIN DATA FRAME
- MM MULTI-MODE FIBER
- MT EMPTY CONDUIT WITH PULL CORD
- MTC CONDUIT WITH WIRING AS INDICATED OR AS REQUIRED
- (N) NEW
- NA NOT APPLICABLE
- (R) REMOVE
- NIC NOT IN CONTRACT
- NIES NOT IN ELECTRICAL SECTION OF THESE PLANS AND SPECIFICATIONS
- NL NIGHT LIGHT
- NPA NATIONAL PURCHASING AGREEMENT
- NBA NATIONAL SERVICE AGREEMENT
- OFI OWNER FURNISHED CONTRACTOR INSTALLED
- OFIO OWNER FURNISHED OWNER INSTALLED
- OL OUTSIDE LIGHT
- OS OCCUPANCY SENSOR
- OSP OUTSIDE PLANT
- PA PUBLIC ADDRESS SYSTEM
- FR PAIR
- (R) REMOVE
- SB STANDBY
- SSB SIGNAL BACKBOARD
- STC SIGNAL TERMINAL CABINET
- SHLD SHIELDED
- SM SINGLE-MODE FIBER
- STP SHIELDED TWISTED PAIR
- SVIS SUPER VIS
- TER IT MAIN CAMPUS TELECOM ROOM
- TMSB TELECOMMUNICATIONS MAIN GROUNDING BUSBAR LOCATED IN IDF
- TR TELECOM ROOM
- UNLESS OTHERWISE NOTED
- UTP UNSHIELDED TWISTED PAIR
- VFCI EQUIPMENT VENDOR FURNISHED, CONTRACTOR INSTALLED
- VFI EQUIPMENT VENDOR FURNISHED, EQUIPMENT VENDOR INSTALLED
- WITH WITH
- WAP WIRELESS ACCESS PANEL
- WG WIRE GUARD
- WP WEATHERPROOF
- 15,30,75,150 FIRE ALARM VISUAL DEVICE SUBSCRIPTS - NUMBER INDICATES LIGHT INTENSITY

ELECTRICAL SYMBOLS LIST

- FLUORESCENT LIGHTING FIXTURE - SURFACE MOUNTED.
- ILLUMINATE EXIT SIGN WITH LIGHTS AND BATTERY BACKUP.
- HORSEPOWER RATED MOTOR DISCONNECT SWITCH.
- KEY PAD SWITCH.
- HALL MOUNTED 2 CIRCUITS OCCUPANCY SWITCH, 48".
- NON-FUSED DISCONNECT SWITCH, SIZE AND TYPE AS REQUIRED.
- 2 HR. THIST TIMER, TORK #C80H.
- HALL MOUNTED OCCUPANCY SENSOR SWITCH.
- CEILING MOUNTED POWER PACK.
- SWITCH SUBSCRIPTS - a = DEVICE CONTROLLED, k = KEY, p = PILOT LIGHT.
- CONTROL EQUIPMENT, N.I.E.S., CONNECT AS REQUIRED.
- HALL AND CEILING MOUNTED JUNCTION BOXES.
- CEILING MOUNTED 15 AMP DUPLEX RECEPTACLE, 48".
- 15 AMP DOUBLE DUPLEX RECEPTACLES, 48". SAME SUBSCRIPTS AS FOR 15 AMP DUPLEX RECEPTACLE.
- 20 AMP DUPLEX RECEPTACLE INSTALLED ABOVE COUNTER, OR AT SPECIAL HEIGHT FOR EQUIPMENT.
- COMBINATION TWO COMPARTMENT SURFACE NON-METALLIC RECESSED, WIREMOLD 8400 SERIES WITH ALL NECESSARY FITTINGS. PROVIDE DEVICES AS SHOWN.
- 15 AMP (2) DUPLEX RECEPTACLE WITH GROUND FAULT INTERRUPTER.
- FIVE DATA OUTLETS.
- POWER REEL, CEILING MOUNTED LIND EQUIPMENT #LE2630B.
- EQUIPMENT IDENTIFICATION TAG, (N.I.E.S.) CONNECT AS REQUIRED, INCLUDING INSTALLATION AND CONNECTION OF REMOTE STARTERS.
- CEF = CEILING EXHAUST FAN
- EF = EXHAUST FAN
- FH = FUME HOOD
- IWH = INSTANTANEOUS WATER HEATER
- REF = ROOF EXHAUST FAN
- VH = VENT HOOD
- TELEPHONE - MATCH (E) SYSTEM.
- SINGLE DATA OUTLET, 48".
- COMBINATION (1) DATA / (1) VOICE OUTLET, 48".
- COMBINATION (2) DATA / (1) VOICE OUTLET, 48".
- FOUR DATA OUTLETS, 48".
- FIVE DATA OUTLETS, 48".
- HALL MOUNTED INTERIOR SPEAKER.
- HALL MOUNTED MEDIA LINK CONTROLLER.
- INTERMEDIATE DISTRIBUTION FRAME
- CEILING MOUNTED PROJECTOR SYSTEM SWITCHER.
- HALL MOUNTED COMPOSITE VIDEO AND AUDIO INPUT.
- HALL MOUNTED YGA AND AUDIO INPUT.
- J-HOOK CABLE SUPPORT SYSTEM - (2) 4" J-HOOK (DATA, PHONE) AND (1) 4" J-HOOK (SIGNAL); INSTALLED ABOVE ACCESSIBLE CEILING AT 48" O.C.
- FLEX CONDUIT
- CONDUIT CONCEALED IN CEILING OR WALL.
- HOMERUN TO RESPECTIVE PANEL OR TERMINAL.
- EXISTING CONDUIT RUN TO REMAIN "AS-IS".
- EXISTING CONDUIT RUN TO BE REMOVED OR ABANDONED.
- NOTE: BRANCH CIRCUIT WITHOUT FURTHER DESIGNATION IS A 2012 WIRE CIRCUIT. FOR MORE THAN 3/12 WIRES AS FOLLOWS: — 3/12 — 4/12 — 4/12, ETC. FOR OTHER SIZES AS FOLLOWS: — 3/10, — 4/10, — 4/6, ETC.
- NUMBER CONSTRUCTION NOTES SPECIFIC TO THE SHEET.
- FIXTURE IDENTIFICATION - NUMBER INDICATES QUANTITY, LETTER INDICATES TYPE.
- EXISTING EXIT LIGHT TO BE REMOVED.
- EXISTING LIGHT FIXTURE TO BE REMOVED.
- EXISTING CEILING MOUNTED LIGHT FIXTURE TO BE REMOVED.
- EXISTING SWITCH TO BE REMOVED.
- EXISTING JUNCTION BOXES TO BE REMOVED.
- EXISTING RECEPTACLES TO BE REMOVED.
- EXISTING EQUIPMENT TO BE DISCONNECTED. REMOVE OUTLET BOX, CONDUIT AND WIRES.
- AC = AIR CONDITIONING
- CEF = CEILING EXHAUST FAN
- REF = ROOF EXHAUST FAN
- UH = UNIT HEATER
- EXISTING INTERIOR SPEAKER TO BE REMOVED.
- EXISTING HALL MOUNTED CLOCK TO BE REMOVED.
- EXISTING TELEPHONE OUTLET TO BE REMOVED.
- EXISTING TELEVISION OUTLET TO BE REMOVED.
- EXISTING PAGING AMP AND HEADEND TO BE REMOVED.
- EXISTING CCTV TO BE REMOVED.

ELECTRICAL SYMBOLS LIST (CONT.)

- EXISTING EXIT LIGHTS.
- EXISTING FLUORESCENT LIGHTING FIXTURE - SURFACE MOUNTED.
- EXISTING INCANDESCENT OR H.I.D. LIGHTING FIXTURE - SUSPENDED.
- EXISTING SINGLE POLE TOGGLE SWITCH, 48".
- EXISTING 15 AMP DUPLEX RECEPTACLE, 48".
- (E) EQUIPMENT IDENTIFICATION TAG, (N.I.E.S.) CONNECT AS REQUIRED.
- R = .
- EXISTING WALL MOUNTED CLOCK.
- EXISTING TELEVISION OUTLET.
- EXISTING TELEPHONE OUTLET.
- EXISTING INTRUSION FIRE DETECTOR.
- EXISTING CEILING MOUNTED INTERIOR SPEAKER.
- EXISTING FIRE ALARM HEAT DETECTOR.
- EXISTING FIRE ALARM SMOKE DETECTOR.
- EXISTING FIRE ALARM HORN/STROBE.
- EXISTING FIRE ALARM EXTERIOR HORN.
- EXISTING FIRE ALARM STROBE, 48", 15cd, 30cd U.O.N.
- EXISTING FIRE ALARM BOOSTER PANEL.
- EXISTING JUNCTION BOXES - SIZE AND TYPE AS REQUIRED.
- EXISTING SUB DISTRIBUTION PANEL.
- EXISTING BACKBOARD.
- EXISTING PANELBOARDS - SEE PANEL SCHEDULES ON SHEET E102.
- EXISTING PAGING AMP AND HEADEND.

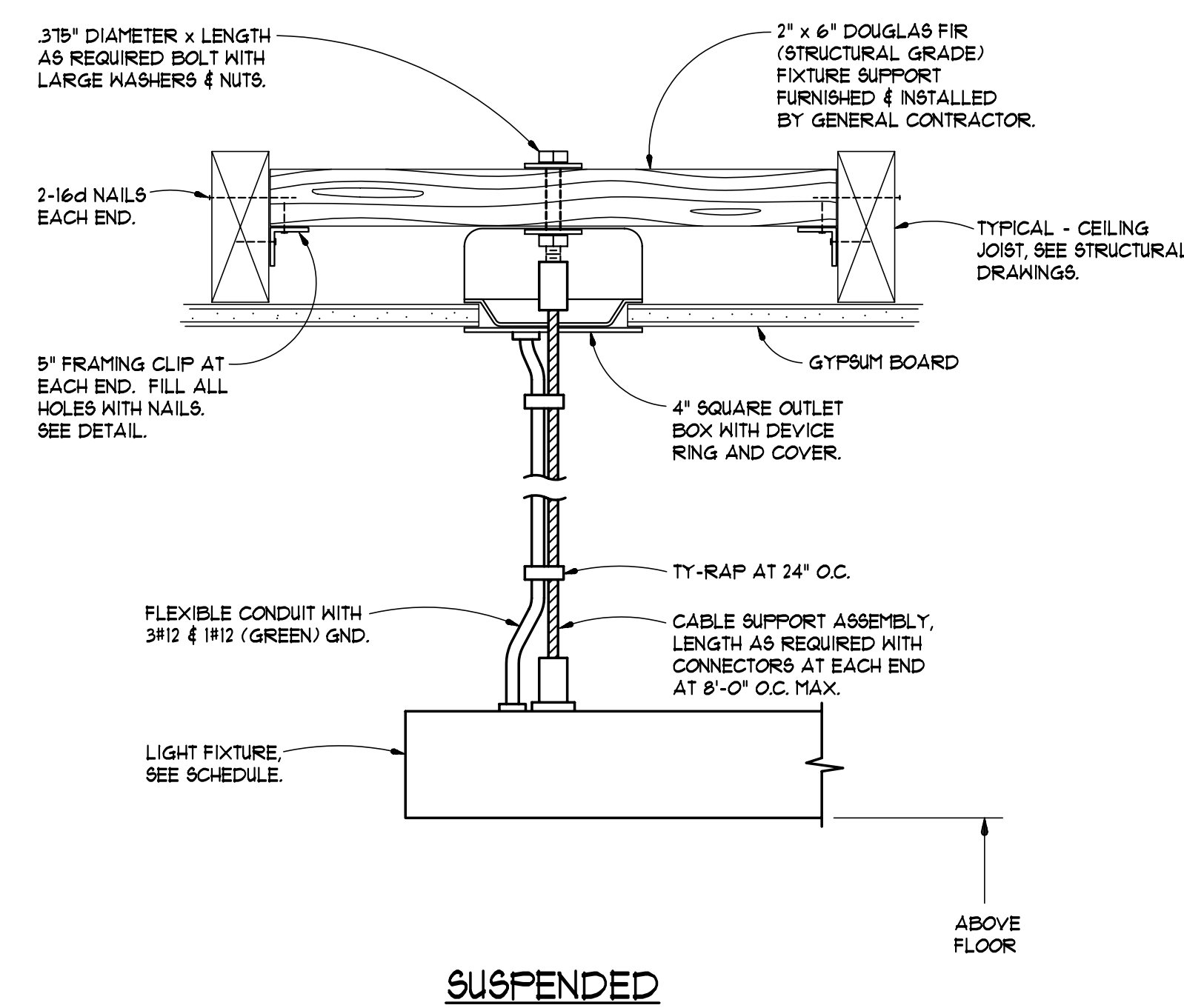

A LIGHT FIXTURE MOUNTING DETAIL
EO.1 NO SCALE

Mt. Diablo High School
Building S - Science Lab Modernization
 2450 Grant Street
 Concord, California 94520
Mt. Diablo Unified School District



FILE NO. xx-xx
 IDENTIFICATION STAMP
 DIV. OF THE STATE ARCHITECT
 OFFICE OF REGULATION SERVICES
 APPLICATION NO. 01-
 AC. FLS. SS.
 DATE

DIVISION OF THE STATE ARCHITECT
 revision date: _____ by _____

HARRY A YEE & ASSOCIATES, INC.
 ELECTRICAL ENGINEERS
 4920 FREEMONT BLVD., SUITE D
 SACRAMENTO, CALIFORNIA 95822
 TEL: 916.454.5319
 FAX: 916.454.4117
 HYA Job #1251



CONSULTANT

nacht&lewis
 600 O Street, Suite 100
 Sacramento, CA 95811
 www.nachtlewis.com
 916.329.4000

ARCHITECT

REVISIONS			
NO.	DESCRIPTION	DATE	REV'D

DATE February 19, 2013
 JOB NO. Y1211.00
 SHEET TITLE

Electrical Symbols List, & Abbreviations

SHEET NO.
EO.1
 SHEET ___ OF ___ TOTAL
 DSA SUBMITTAL SET

ONE AND ONE-HALF INCH = ONE FOOT
 ONE INCH = ONE FOOT
 THREE-QUARTERS INCH = ONE FOOT
 ONE-HALF INCH = ONE FOOT
 ONE-QUARTER INCH = ONE FOOT
 ONE-EIGHTH INCH = ONE FOOT
 ONE-SIXTEENTH INCH = ONE FOOT
 ONE INCH = TWENTY FEET

ONE INCH = TWENTY FEET
ONE-SIXTEENTH INCH = ONE FOOT
ONE-EIGHTH INCH = ONE FOOT
ONE-FOURTH INCH = ONE FOOT
ONE-HALF INCH = ONE FOOT
THREE-QUARTERS INCH = ONE FOOT
ONE AND ONE-HALF INCH = ONE FOOT

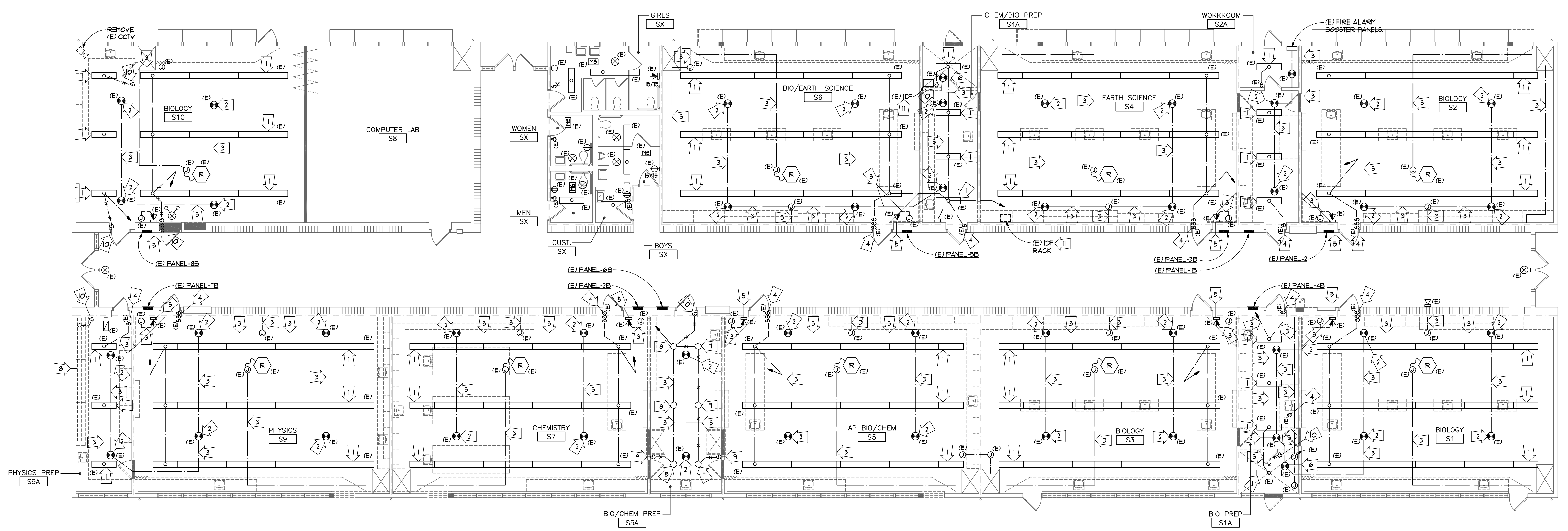

A
E1.1 LIGHTING AND FIRE ALARM DEMOLITION PLAN
SCALE: 1/8" = 1'-0"

CONSTRUCTION NOTES:

- 1 REMOVE (E) LIGHT FIXTURE FOR INSTALLATION OF NEW CEILING. RE-INSTALL TO ORIGINAL OPERATING CONDITIONS.
- 2 REMOVE (E) FIRE ALARM SMOKE DETECTOR FOR INSTALLATION OF NEW CEILING. RE-INSTALL TO ORIGINAL OPERATING CONDITIONS.
- 3 REMOVE (E) SURFACE CONDUIT FOR INSTALLATION OF NEW CEILING. RE-INSTALL TO ORIGINAL OPERATING CONDITIONS.
- 4 REMOVE (E) LIGHT SWITCHES FOR INSTALLATION OF NEW CEILING. RE-INSTALL TO ORIGINAL OPERATING CONDITIONS.
- 5 REMOVE (E) FIRE ALARM DEVICE FOR INSTALLATION OF NEW CEILING. RE-INSTALL TO ORIGINAL OPERATING CONDITIONS.
- 6 REMOVE & RELOCATE EXISTING FIRE ALARM DETECTOR. RECONNECT WIRES TO PROVIDE CIRCUIT CONTINUITY. PROVIDE BLANK COVER. SEE SHEET E5.0 FOR NEW LOCATION.
- 7 REMOVE EXISTING LIGHT FIXTURE INCLUDING OUTLET BOX, CONDUIT & WIRES.
- 8 REMOVE EXISTING LIGHT FIXTURE. OUTLET BOX, CONDUIT AND WIRES TO REMOVE.
- 9 REMOVE EXISTING LIGHT SWITCH INCLUDING OUTLET BOX, CONDUIT, & WIRES.
- 10 REMOVE EXISTING LIGHT SWITCH, CONDUIT & WIRES.
- 11 REMOVE EXISTING IDF INCLUDING CONDUIT, WIRES & FIBER.

Mt. Diablo High School
Building S - Science Lab Modernization
2450 Grant Street
Concord, California 94520



FILE NO. xx-xx
IDENTIFICATION STAMP
DIV. OF THE STATE ARCHITECT
OFFICE OF REGULATION SERVICES
APPLICATION NO. 01-
AC. FLS. SS
DATE

DIVISION OF THE STATE ARCHITECT
revision date: by

HARRY A YEE & ASSOCIATES, INC.
ELECTRICAL ENGINEERS
4920 FREEMONT BLVD., SUITE D
SACRAMENTO, CALIFORNIA 95822
TEL: 916.454.5319
FAX: 916.454.4117
HYA Job #1251



CONSULTANT

nacht&lewis
600 O Street, Suite 100
Sacramento, CA 95811
www.nachtlewis.com
916.329.4000

ARCHITECT

REVISIONS			
NO.	DESCRIPTION	DATE	REV'D

DATE February 19, 2013
JOB NO. Y1211.00
SHEET TITLE

Lighting and Fire Alarm Demolition Plan

SHEET NO.

E1.1

SHEET ___ OF ___ TOTAL
DSA SUBMITTAL SET

ONE AND ONE-HALF INCH = ONE FOOT
ONE INCH = ONE FOOT
THREE-QUARTERS INCH = ONE FOOT
ONE-HALF INCH = ONE FOOT
ONE-QUARTER INCH = ONE FOOT
ONE-EIGHTH INCH = ONE FOOT
ONE-SIXTEENTH INCH = ONE FOOT
ONE INCH = TWENTY FEET

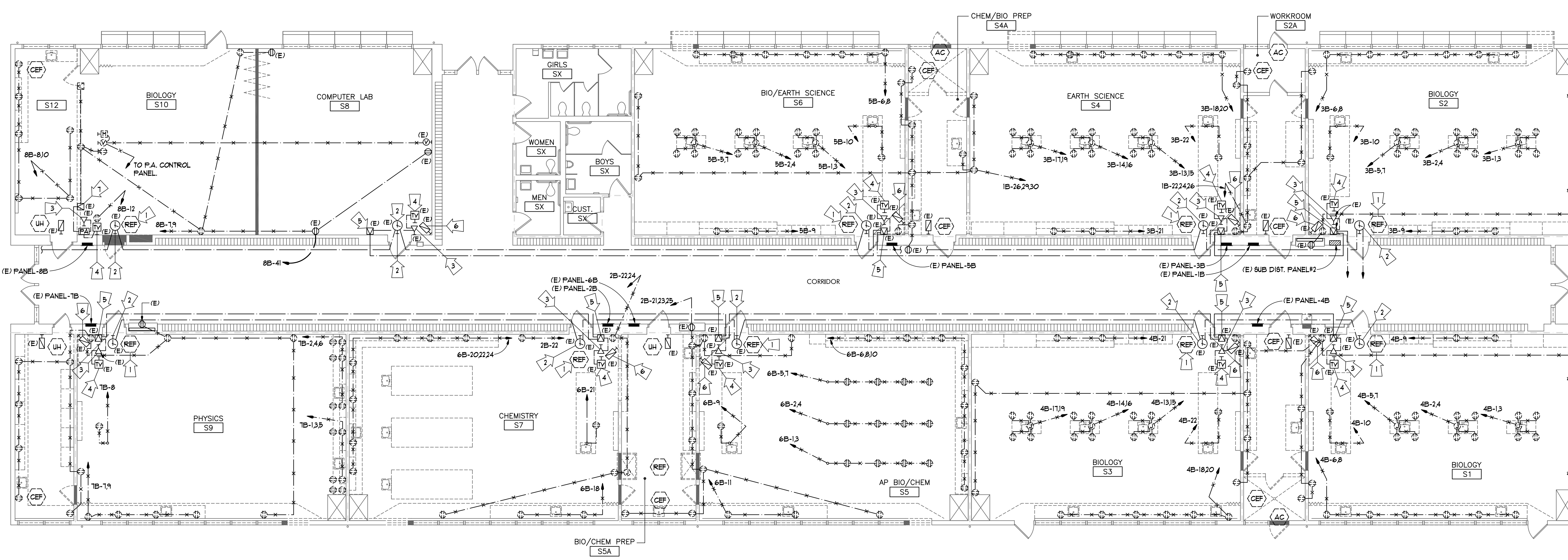

A
E1.2 POWER AND SIGNAL DEMOLITION PLAN
SCALE: 1/8" = 1'-0"
N

- CONSTRUCTION NOTES:**
- 1 DISCONNECT EXISTING REF. REMOVE DISCONNECT SWITCH, CONDUIT AND WIRES TO REMAIN.
 - 2 REMOVE (E) CLOCK INCLUDING SURFACE CONDUIT, WIRES AND BOX FOR INSTALLATION OF NEW FINISHES. PROVIDE BOX EXTENSION. RE-INSTALL TO ORIGINAL OPERATING CONDITIONS.
 - 3 REMOVE (E) TELEPHONE INCLUDING SURFACE CONDUIT, WIRES AND BOX FOR INSTALLATION OF NEW FINISHES. PROVIDE BOX EXTENSION. RE-INSTALL TO ORIGINAL OPERATING CONDITIONS.
 - 4 REMOVE (E) TELEVISION INCLUDING SURFACE CONDUIT, WIRES AND BOX FOR INSTALLATION OF NEW FINISHES. PROVIDE BOX EXTENSION. RE-INSTALL TO ORIGINAL OPERATING CONDITIONS.
 - 5 REMOVE (E) SPEAKER INCLUDING SURFACE CONDUIT, WIRES AND BOX FOR INSTALLATION OF NEW FINISHES. PROVIDE BOX EXTENSION. RE-INSTALL TO ORIGINAL OPERATING CONDITIONS.
 - 6 REMOVE EXISTING INTRUSION ALARM DETECTOR INCLUDING SURFACE CONDUIT, WIRES AND BOX FOR INSTALLATION OF NEW FINISHES. PROVIDE BOX EXTENSION. RE-INSTALL TO ORIGINAL OPERATING CONDITIONS.
 - 7 REMOVE AND RELOCATE (E) SPEAKER WITH ALL NECESSARY CONDUIT, WIRES AND BOXES.

MDUSD
MOUNTAIN DIABLO UNIFIED SCHOOL DISTRICT

**Mt. Diablo High School
Building S - Science Lab Modernization**

2450 Grant Street
Concord, California 94520

Mt. Diablo Unified School District

FILE NO. xx-xx
IDENTIFICATION STAMP
DIV. OF THE STATE ARCHITECT
OFFICE OF REGULATION SERVICES

APPLICATION NO.
01-
AC. FLS. SS
DATE

DIVISION OF THE STATE ARCHITECT
revision date: by

HARRY A. YEE & ASSOCIATES, INC.
ELECTRICAL ENGINEERS
4920 FREEMONT BLVD., SUITE D
SACRAMENTO, CALIFORNIA 95822
TEL: 916.454.5319
FAX: 916.454.4117
HYA Job #1251

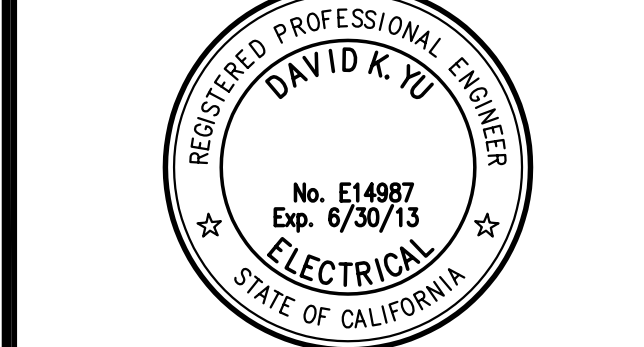

CONSULTANT

nacht&lewis
600 O Street, Suite 100
Sacramento, CA 95811
www.nachtandlewis.com
916.329.4000

ARCHITECT

REVISIONS

NO.	DESCRIPTION	DATE	REV'D

DATE February 19, 2013
JOB NO. Y1211.00
SHEET TITLE
Power and Signal Demolition Plan

SHEET NO.
E1.2
SHEET ___ OF ___ TOTAL
DSA SUBMITTAL SET

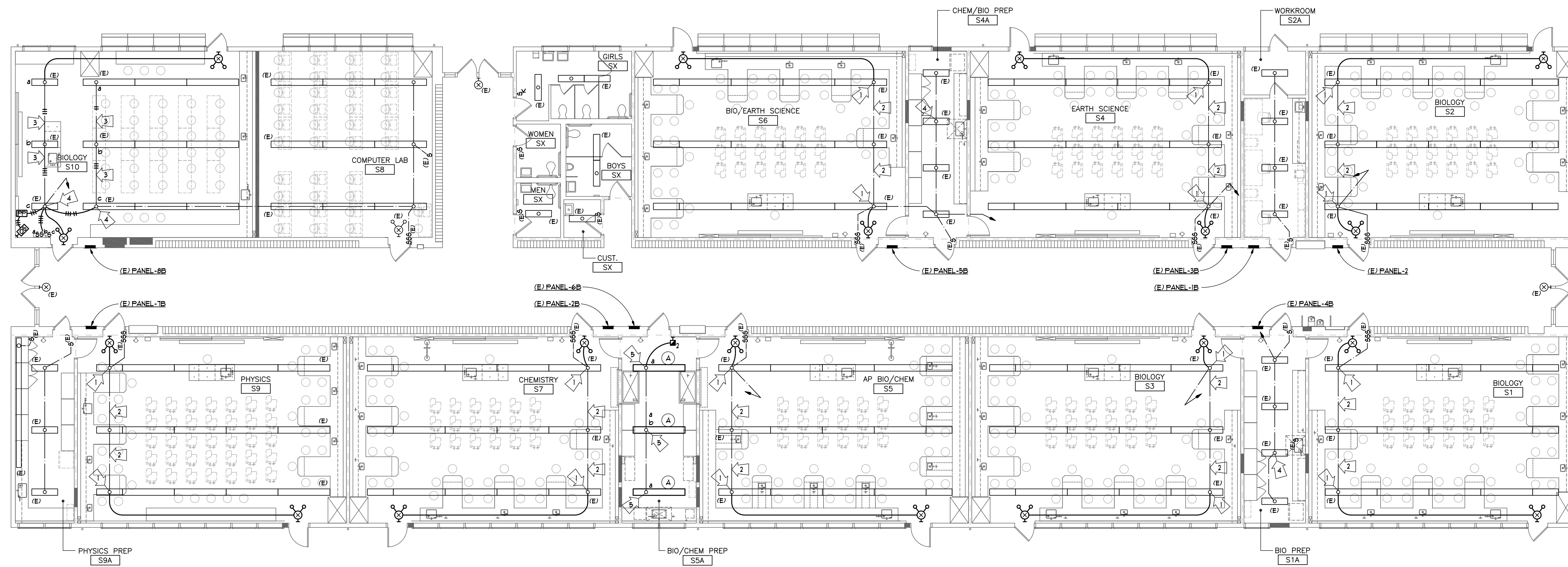

A
E2.0 LIGHTING FLOOR PLAN
SCALE: 1/8" = 1'-0"

- CONSTRUCTION NOTES:**
- 1 EXTEND LIGHTING CIRCUIT TO ILLUMINATED EMERGENCY EXIT SIGN / LIGHT.
 - 2 PULL-IN ADDITIONAL #12 WIRE FOR LINE VOLTAGE.
 - 3 PULL-IN WIRES AS SHOWN.
 - 4 EXTEND LIGHTING CIRCUIT AS SHOWN WITH CONDUIT & WIRES TO CONTROL ALL LIGHT FIXTURES IN ROOM FROM LIGHT SWITCHES.
 - 5 INSTALL NEW LIGHT FIXTURE OVER (E) OUTLET BOX. PULL-IN WIRES TO CONTROL LIGHT FIXTURES AS SHOWN.

ONE INCH = TWENTY FEET
ONE-SIXTEENTH INCH = ONE FOOT
ONE-EIGHTH INCH = ONE FOOT
ONE-FOURTH INCH = ONE FOOT
ONE-HALF INCH = ONE FOOT
THREE-QUARTERS INCH = ONE FOOT
ONE INCH = ONE FOOT
ONE AND ONE-HALF INCH = ONE FOOT

MDUSD
MOUNTAIN DIABLO UNIFIED SCHOOL DISTRICT

**Mt. Diablo High School
Building S - Science Lab Modernization**

2450 Grant Street
Concord, California 94520

Mt. Diablo Unified School District

FILE NO. xx-xx
IDENTIFICATION STAMP
DIV. OF THE STATE ARCHITECT
OFFICE OF REGULATION SERVICES

APPLICATION NO.
01-
AC. FLS. SS.
DATE

DIVISION OF THE STATE ARCHITECT
revision date: by

HARRY A YEE & ASSOCIATES, INC.
ELECTRICAL ENGINEERS
4920 FREEMONT BLVD., SUITE D
SACRAMENTO, CALIFORNIA 95822
TEL: 916.454.5319
FAX: 916.454.4117
HYA Job #1251



CONSULTANT

nacht&lewis
600 O Street, Suite 100
Sacramento, CA 95811
www.nachtlewis.com
916.329.4000

ARCHITECT

REVISIONS

NO.	DESCRIPTION	DATE	REV'D

DATE February 19, 2013
JOB NO. Y1211.00
SHEET TITLE

**Lighting
Floor Plan**

SHEET NO.
E2.0

SHEET ___ OF ___ TOTAL
DSA SUBMITTAL SET

ONE INCH = TWENTY FEET
ONE-SIXTEENTH INCH = ONE FOOT
ONE-EIGHTH INCH = ONE FOOT
ONE-FOURTH INCH = ONE FOOT
ONE-HALF INCH = ONE FOOT
THREE-QUARTERS INCH = ONE FOOT
ONE INCH = ONE FOOT
ONE AND ONE-HALF INCH = ONE FOOT

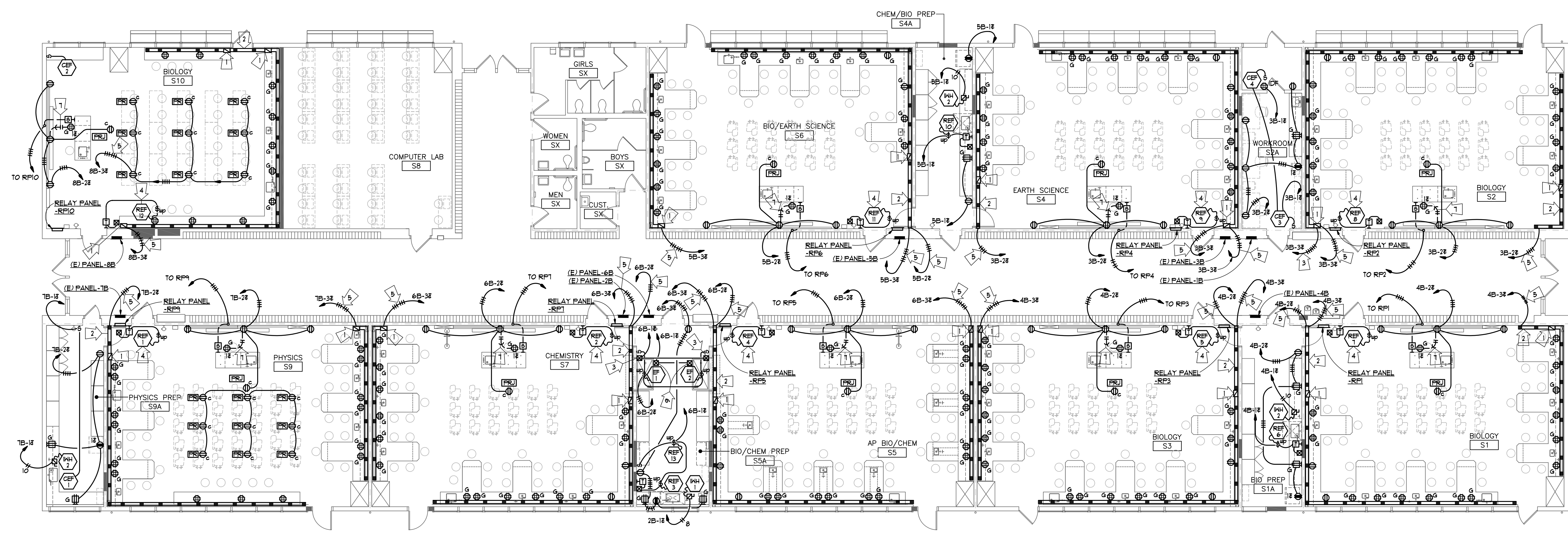

A
E3.0 POWER FLOOR PLAN
SCALE: 1/8" = 1'-0"
N

- CONSTRUCTION NOTES:**
- 1 RISE UP ON WALL TO CEILING.
 - 2 ROUTE HIGH ON WALL BELOW CEILING.
 - 3 RATED DOOR CONTROLLER.
 - 4 RECONNECT REF TO EXISTING CIRCUIT WITH NEW DISCONNECT SWITCH. PROVIDE ALL NECESSARY CONDUIT & WIRES.
 - 5 ROUTE CIRCUITS THRU RELAY PANEL.
 - 6 FUME HOOD.
 - 7 BAW CUT CONCRETE. PATCH TO MATCH EXISTING.

Mt. Diablo High School
Building S - Science Lab Modernization
2450 Grant Street
Concord, California 94520
Mt. Diablo Unified School District



FILE NO. xx-xx
IDENTIFICATION STAMP
DIV. OF THE STATE ARCHITECT
OFFICE OF REGULATION SERVICES
APPLICATION NO. 01-
AC. FLS. SS
DATE

DIVISION OF THE STATE ARCHITECT
revision date: by

HARRY A YEE & ASSOCIATES, INC.
ELECTRICAL ENGINEERS
4920 FREEMONT BLVD., SUITE D
SACRAMENTO, CALIFORNIA 95822
TEL: 916.454.5319
FAX: 916.454.4117
HYA Job #1251

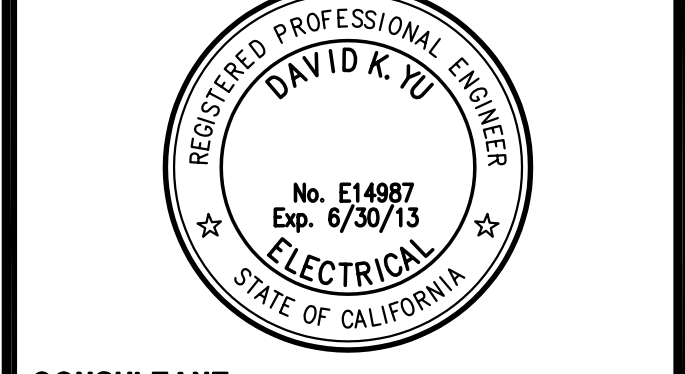

CONSULTANT
nacht&lewis
600 O Street, Suite 100
Sacramento, CA 95811
www.nachtandlewis.com
916.329.4000

ARCHITECT

REVISIONS			
NO.	DESCRIPTION	DATE	REV'D

DATE February 19, 2013
JOB NO. Y1211.00
SHEET TITLE

Power Floor Plan

SHEET NO.
E3.0
SHEET ___ OF ___ TOTAL
DSA SUBMITTAL SET

ONE AND ONE-HALF INCH = ONE FOOT
THREE-QUARTERS INCH = ONE FOOT
ONE-HALF INCH = ONE FOOT
ONE-QUARTER INCH = ONE FOOT
ONE-EIGHTH INCH = ONE FOOT
ONE-SIXTEENTH INCH = ONE FOOT
ONE INCH = TWENTY FEET

A SIGNAL FLOOR PLAN
E4.0 SCALE: 1/8" = 1'-0"
N

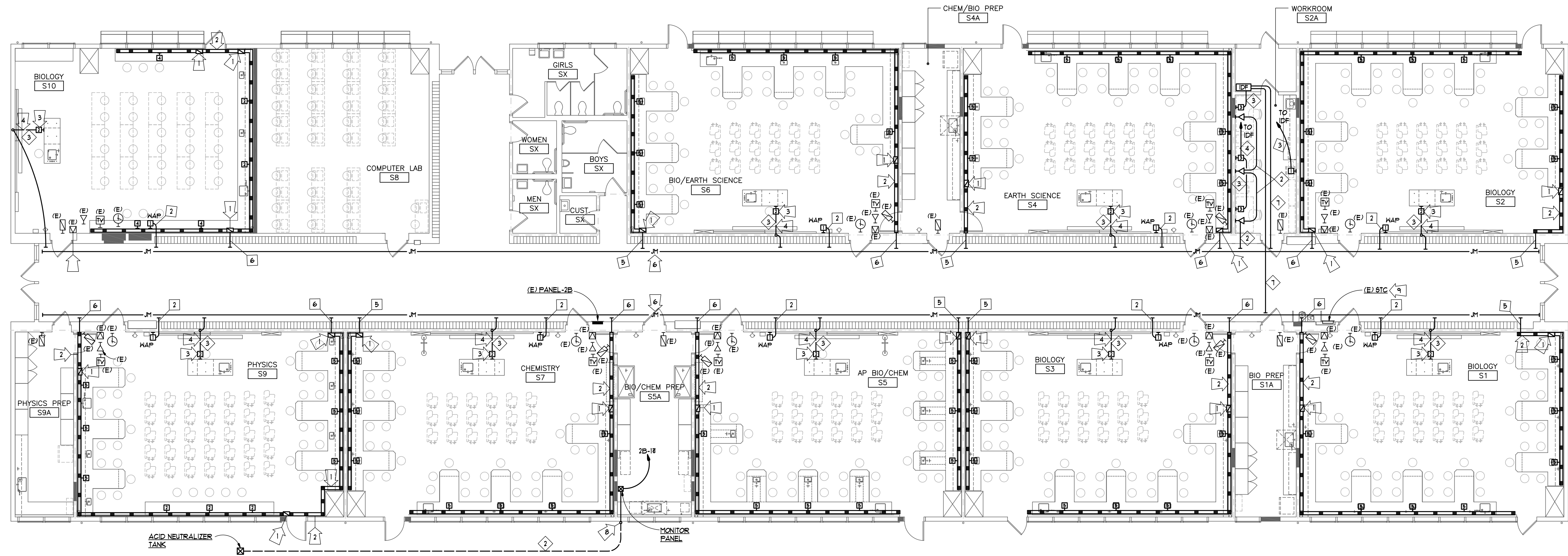

C TELEPHONE SYSTEM RISER DIAGRAM
E4.0 NO SCALE

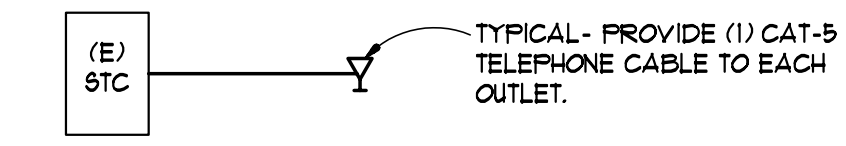

B DATA SYSTEM RISER DIAGRAM
E4.0 NO SCALE

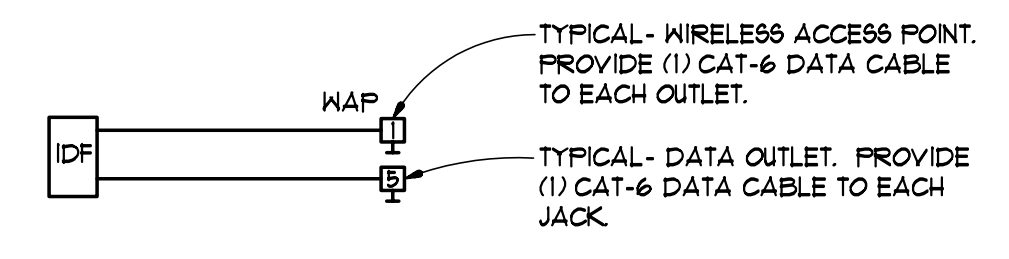

CIRCUIT NOTES:

- 1 1/2" MTC
- 2 3/4" MTC
- 3 1" MTC
- 4 1 1/4" MTC
- 5 2-1" MTC
- 6 2-1 1/4" MTC
- 7 2-4" MTC

CONSTRUCTION NOTES:

- 1 RISE UP ON WALL TO CEILING.
- 2 ROUTE HIGH ON WALL BELOW CEILING.
- 3 COORDINATE EXACT LOCATION WITH CASEWORK.
- 4 SAW CUT CONCRETE AS REQUIRED. PATCH TO MATCH EXISTING.
- 5 ROUTE CONDUIT ABOVE CEILING.
- 6 INSTALL J-HOOKS ABOVE CEILING.
- 7 RELOCATE (E) SPEAKER WITH ALL NECESSARY CONDUIT, WIRES AND BOXES.
- 8 1"LB INTO BUILDING. SEAL PENETRATION WATER-TIGHT.
- 9 PROVIDE 3-1" HT ABOVE CEILING.

Mt. Diablo High School
Building S - Science Lab Modernization
2450 Grant Street
Concord, California 94520
Mt. Diablo Unified School District



FILE NO. xx-xx
IDENTIFICATION STAMP
DIV. OF THE STATE ARCHITECT
OFFICE OF REGULATION SERVICES
APPLICATION NO. 01-
AC. FLS. SS
DATE

DIVISION OF THE STATE ARCHITECT
revision date: by

HARRY A YEE & ASSOCIATES, INC.
ELECTRICAL ENGINEERS
4920 FREEMONT BLVD., SUITE D
SACRAMENTO, CALIFORNIA 95822
TEL: 916.454.5319
FAX: 916.454.4117
HYA Job #1251

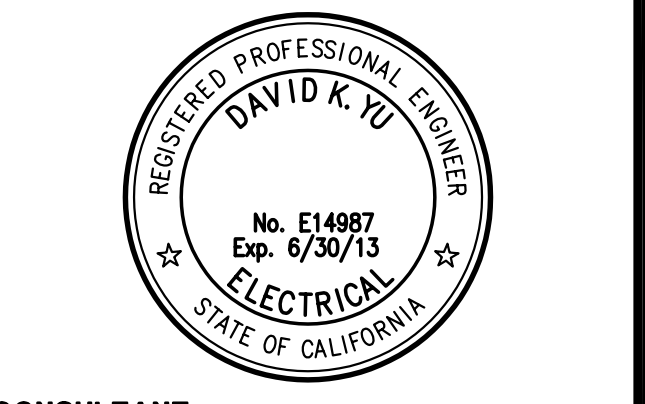

CONSULTANT

nacht&lewis
600 O Street, Suite 100
Sacramento, CA 95811
www.nachtlewis.com
916.329.4000

ARCHITECT

REVISIONS			
NO.	DESCRIPTION	DATE	REV'D

DATE February 19, 2013
JOB NO. Y1211.00
SHEET TITLE

Signal Floor Plan

SHEET NO.

E4.0

SHEET ___ OF ___ TOTAL
DSA SUBMITTAL SET

ONE INCH = TWENTY FEET
 ONE-SIXTEENTH INCH = ONE FOOT
 ONE-EIGHTH INCH = ONE FOOT
 ONE-FOURTH INCH = ONE FOOT
 ONE-HALF INCH = ONE FOOT
 THREE-QUARTERS INCH = ONE FOOT
 ONE INCH = ONE FOOT
 ONE INCH = ONE FOOT
 ONE AND ONE-HALF INCH = ONE FOOT

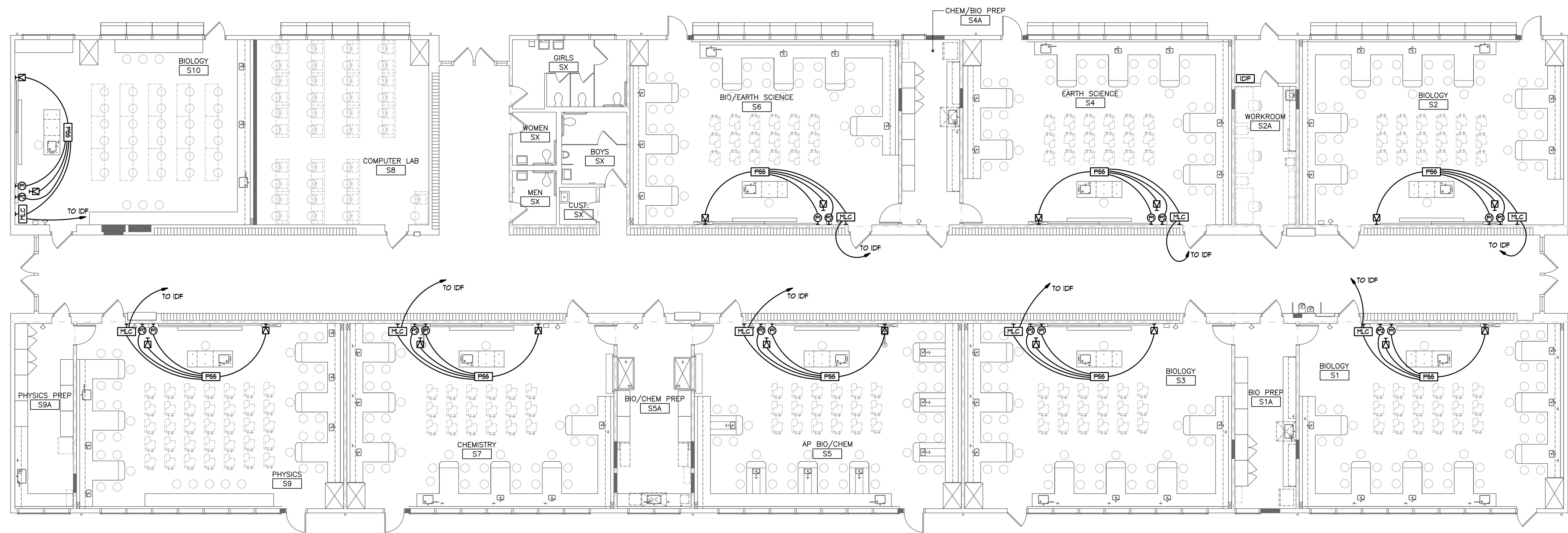

A
E4.1
 A/V FLOOR PLAN
 SCALE: 1/8" = 1'-0"

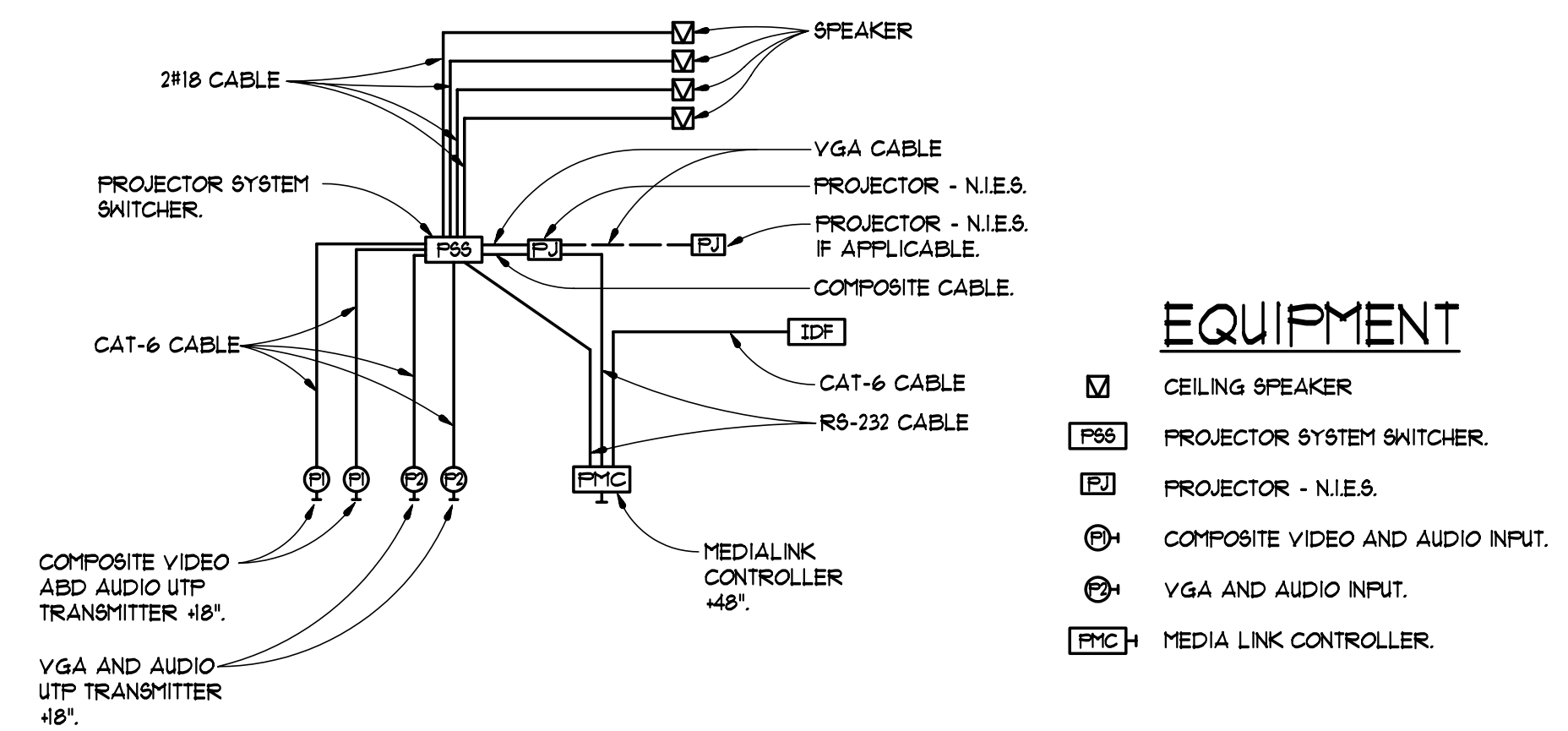

B
E4.1
 CLASSROOM A/V SYSTEM
 WIRING DIAGRAM
 NO SCALE

- EQUIPMENT**
- ☐ CEILING SPEAKER
 - PSB PROJECTOR SYSTEM SWITCHER
 - PLC PROJECTOR - N.I.E.S.
 - ⊕ COMPOSITE VIDEO AND AUDIO INPUT
 - ⊕ VGA AND AUDIO INPUT
 - PLC MEDIA LINK CONTROLLER

Mt. Diablo High School
 Building S - Science Lab Modernization
 2450 Grant Street
 Concord, California 94520
 Mt. Diablo Unified School District



FILE NO. xx-xx
 IDENTIFICATION STAMP
 DIV. OF THE STATE ARCHITECT
 OFFICE OF REGULATION SERVICES
 APPLICATION NO. 01-
 AC. FLS. SS
 DATE

DIVISION OF THE STATE ARCHITECT
 revision date: by:

HARRY A YEE & ASSOCIATES, INC.
 ELECTRICAL ENGINEERS
 4920 FREEMONT BLVD., SUITE D
 SACRAMENTO, CALIFORNIA 95822
 TEL: 916.454.5319
 FAX: 916.454.4117
 HYA job #1251

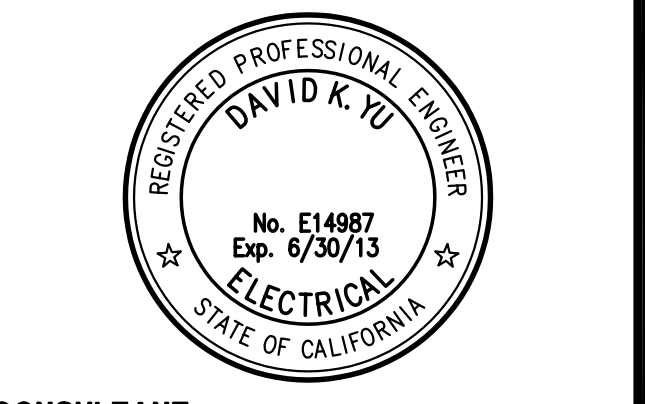

CONSULTANT

nacht&lewis
 600 O Street, Suite 100
 Sacramento, CA 95811
 www.nachtlewis.com
 916.329.4000

ARCHITECT

REVISIONS

NO.	DESCRIPTION	DATE	REV'D

DATE February 19, 2013
 JOB NO. Y1211.00
 SHEET TITLE

**A/V
 Floor Plan**

SHEET NO.

E4.1

SHEET ___ OF ___ TOTAL
 DSA SUBMITTAL SET

FIRE ALARM WIRE SCHEDULE					
DESIG.	DESCRIPTION	USE	SYSTEM	O.D. (inches)	AREA (sq. inches)
F1	1 FR.#16, 5TP, ADDRESSABLE LOOP, FPL, LON CAP, WPK #D9H	BLDG. INITIATING	FIRE ALARM	0.226	0.0401
F2	1 FR.#14, 5TP, ADDRESSABLE LOOP, FPL, NET LOC, LON CAP, WPK #A229S	SITE INITIATING		0.35	0.0962
F3	2#10, THWN	BLDG. SIGNAL		0.13 EA.	0.0265
F4	2#10, THWN	SITE SIGNAL		0.164 EA.	0.0422
F5	2#14 FPL	HARDWIRED INT.			

FIRE ALARM EQUIPMENT SCHEDULE					
SYMBOL	EQUIPMENT / DEVICE	MANUFACTURER AND MODEL NUMBER	CFM LISTING NO.	STANDBY AMPS	ALARM AMPS
ES	CONTROL RELAY	ESTH 91GA-CR	1300-1651-0121	0.0001	0.0001

BATTERY CALCULATIONS					
EQUIPMENT / DEVICE	QUANTITY	DEVICE STANDBY AMPS	TOTAL STANDBY AMPS	DEVICE ALARM AMPS	TOTAL ALARM AMPS
CONTROL RELAY	2	0.0001	0.0002	0.0001	0.0002
TOTALS:			0.0002 AMPS		0.0002 AMPS

NOTES:

- BATTERY CALCULATIONS ARE FOR 24 HOURS (STANDBY) PLUS 5 MINUTES (ALARM).
 FORMULA: MINIMUM BATTERY AMP-HRS REQUIRED =
 (TOTAL STANDBY CURRENT) x (24 HRS) + (TOTAL ALARM CURRENT) x (0.0833 HRS) + (10%)
 MINIMUM BATTERY REQUIRED (AMP-HRS) = 0.06
 (E) BATTERY PROVIDED (AMP-HRS) = 60.0

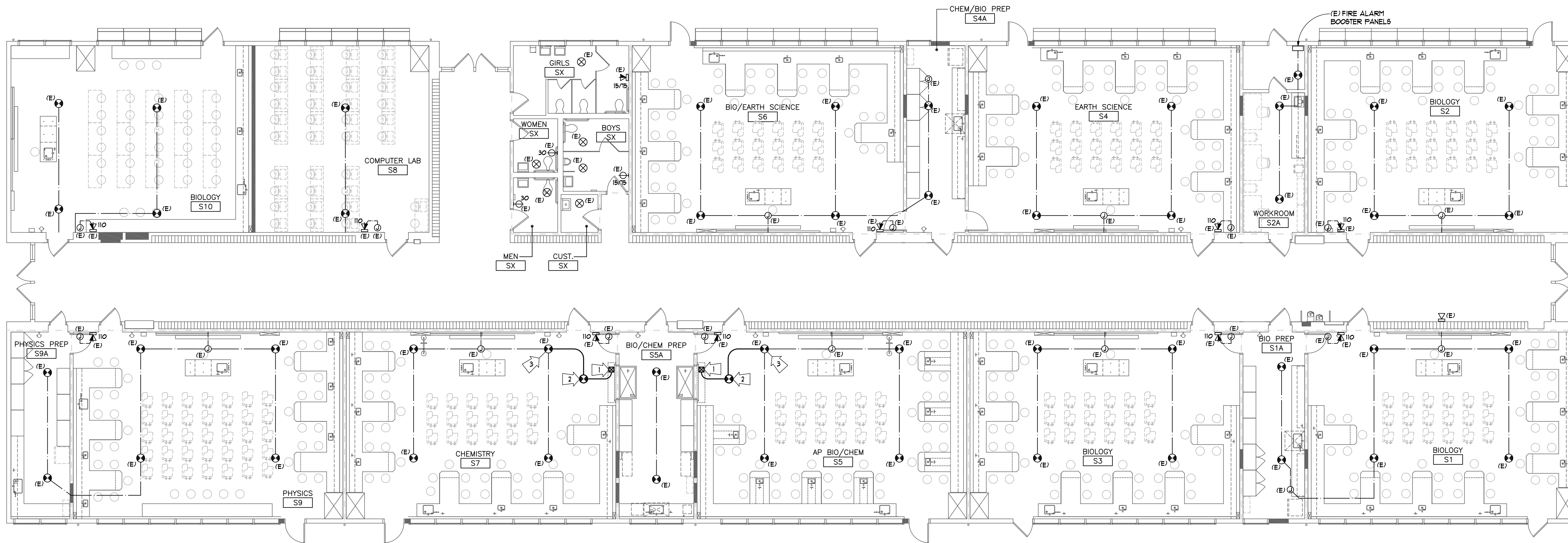

A FIRE ALARM FLOOR PLAN
 SCALE: 1/8" = 1'-0"
 E5.0

FIRE ALARM SCOPE OF WORK

- APPROVAL APPLICATION #105201-INC1.
- EXISTING FIRE ALARM SYSTEM TO REMAIN 'AS-IS' EXCEPT FOR RELOCATION OF (2) CEILING SMOKE DETECTORS.
- CONNECT (2) RATED DOOR CONTROLLERS TO FIRE ALARM SYSTEM WITH ESTH 91GA-CR CONTROL RELAY MODULES.

CONSTRUCTION NOTES:

- RATED DOOR CONTROLLER. CONNECT TO FIRE ALARM SYSTEM WITH CONTROL RELAY MODULE & (1) F1 WIRE.
- EXISTING FIRE ALARM SMOKE DETECTOR RELOCATED. REPROGRAM & CONNECT AS REQUIRED TO ACTIVATE RATED DOOR. PROVIDE ALL NECESSARY HARDWARE.
- EXTEND SLC AS SHOWN WITH CONDUIT & (1) F1 WIRE.

Mt. Diablo High School
Building S - Science Lab Modernization
 2450 Grant Street
 Concord, California 94520
Mt. Diablo Unified School District



FILE NO. xx-xx
 IDENTIFICATION STAMP
 DIV. OF THE STATE ARCHITECT
 OFFICE OF REGULATION SERVICES
 APPLICATION NO. 01-
 AC. FLS. SS
 DATE

DIVISION OF THE STATE ARCHITECT
 revision date: by:

HARRY A YEE & ASSOCIATES, INC.
 ELECTRICAL ENGINEERS
 4920 FREEMONT BLVD., SUITE D
 SACRAMENTO, CALIFORNIA 95822
 TEL: 916.454.5319
 FAX: 916.454.4117
 HYA job #1251



CONSULTANT

nacht&lewis
 600 O Street, Suite 100
 Sacramento, CA 95811
 www.nachtlewis.com
 916.329.4000

ARCHITECT

REVISIONS			
NO.	DESCRIPTION	DATE	REV'D

DATE February 19, 2013
 JOB NO. Y1211.00
 SHEET TITLE

Fire Alarm Floor Plan

SHEET NO.

E5.0

SHEET ___ OF ___ TOTAL

DSA SUBMITTAL SET

ONE AND ONE-HALF INCH = ONE FOOT
 ONE INCH = ONE FOOT
 THREE-QUARTERS INCH = ONE FOOT
 ONE-HALF INCH = ONE FOOT
 ONE-QUARTER INCH = ONE FOOT
 ONE-EIGHTH INCH = ONE FOOT
 ONE-SIXTEENTH INCH = ONE FOOT
 ONE INCH = TWENTY FEET

MINIMUM AIC: 22,000		VOLTAGE: <input type="checkbox"/> 120/208 <input type="checkbox"/> 480/277 <input type="checkbox"/> 120/240				
TYPE: <input type="checkbox"/> FLUSH <input checked="" type="checkbox"/> SURFACE <input type="checkbox"/> FREESTANDING		PHASE: <input type="checkbox"/> 1-PHASE <input checked="" type="checkbox"/> 3-PHASE				
MOUNTING: <input type="checkbox"/> CU <input checked="" type="checkbox"/> AL		BUS AMP: 225 <input type="checkbox"/> CU <input checked="" type="checkbox"/> AL				
MISC: <input type="checkbox"/> MLO <input checked="" type="checkbox"/> BKR		MAIN AMP: 225 <input type="checkbox"/> MLO <input checked="" type="checkbox"/> BKR				
FED FROM:		FED FROM:				
KVA	USE	BKR No.	Phase No.	BKR No.	USE	KVA
--	(E) LIGHTING RM. A11	20/1	1 A	2 20/1	(E) LIGHTING RM. A16	--
	(E) LIGHTING RM. A17	3 B	4		(E) LIGHTING RM. A16	
	(E) LIGHTING RM. A17	5 C	6		(E) LIGHTING RM. A16	
	(E) LIGHTING RM. A18	7 A	8		(E) LIGHTING RM. A14	
	(E) LIGHTING RM. A20	9 B	10		(E) LIGHTING RM. A13	
	(E) LIGHTING RM. A20	11 C	12		(E) LIGHTING RM. A13	
	(E) LIGHTING RM. A20	13 A	14		(E) LIGHTING RM. A10	
	(E) LIGHTING RM. A11	15 B	16		(E) LIGHTING RM. A10	
	(E) LIGHTING HALLWAY	17 C	18		(E) LIGHTING RM. A10	
	(E) LIGHTING EXTERIOR	19 A	20		(E) LIGHTING RM. A10	
	SPARE	21 B	22		SPARE	
		23 C	24			
		25 A	26			
	(E) HEATER RM1	27 B	28			
	(E) HEATER RM3	29 C	30			
	(E) HEATER RM12	31 A	32		(E) HEATER	
	(E) HEATER RM14	33 B	34			
--	(E) LOAD	20/2	35 C	36		--
		37 A	38	20/2	(E) LOAD	
		39 B	40			
		41 C	42	20/1	SPARE	

LOAD KVA: .

MINIMUM AIC: 22,000		VOLTAGE: <input type="checkbox"/> 120/208 <input type="checkbox"/> 480/277 <input type="checkbox"/> 120/240				
TYPE: <input type="checkbox"/> FLUSH <input checked="" type="checkbox"/> SURFACE <input type="checkbox"/> FREESTANDING		PHASE: <input type="checkbox"/> 1-PHASE <input checked="" type="checkbox"/> 3-PHASE				
MOUNTING: <input type="checkbox"/> CU <input checked="" type="checkbox"/> AL		BUS AMP: 225 <input type="checkbox"/> CU <input checked="" type="checkbox"/> AL				
MISC: <input type="checkbox"/> MLO <input checked="" type="checkbox"/> BKR		MAIN AMP: 225 <input type="checkbox"/> MLO <input checked="" type="checkbox"/> BKR				
FED FROM:		FED FROM:				
KVA	USE	BKR No.	Phase No.	BKR No.	USE	KVA
--	(E) LIGHTING RM. 5	20/1	1 A	2 20/1	(E) LIGHTING BOYS RESTROOM	--
	(E) LIGHTING RM. 5	3 B	4		(E) LIGHTING GIRLS REST RM.	
	(E) LIGHTING RM. 5	5 C	6		(E) LIGHTING RM. 9	
	(E) LIGHTING RM. 5	7 A	8		(E) LIGHTING RM. 9	
	(E) LIGHTING RM. 1	9 B	10		(E) LIGHTING RM. 9	
	(E) LIGHTING ATTIC	11 C	12		(E) LIGHTING CORRIDOR 1	
	(E) LIGHTING RM. 1	13 A	14		(E) LIGHTING CORRIDOR 1	
	(E) HEATER-5	15 B	16		(E) HEATER-1	
		17 C	18		(E) HEATER-4	
--	(E) LOAD	20/2	19 A	20	(E) LOAD	--
	SPARE	21 B	22			
		23 C	24	40/2	INH-1	8.0 *
		25 A	26	20/1	SPARE	
	(E) RECEPTACLE CIRC. PUMP	27 B	28			
	(E) CUST. CORR. RECEPT.	29 C	30		MONITOR PANEL	
	(E) RECEPT. BOYS RESTRM. FAN	31 A	32			
	(E) LOAD	33 B	34	30/2	(E) LOAD	--
		35 C	36			
		37 A	38	20/2	(E) HEATER	--
	(E) HEATER	20/2	39 B	40		
	(E) LOAD	20/1	41 C	42		--

LOAD KVA: .

* REMOVE 2-20/1 AND PROVIDE 1-40/2 WITH HARDWARE.

MINIMUM AIC: 22,000		VOLTAGE: <input type="checkbox"/> 120/208 <input type="checkbox"/> 480/277 <input type="checkbox"/> 120/240				
TYPE: <input type="checkbox"/> FLUSH <input checked="" type="checkbox"/> SURFACE <input type="checkbox"/> FREESTANDING		PHASE: <input type="checkbox"/> 1-PHASE <input checked="" type="checkbox"/> 3-PHASE				
MOUNTING: <input type="checkbox"/> CU <input checked="" type="checkbox"/> AL		BUS AMP: 100 <input type="checkbox"/> CU <input checked="" type="checkbox"/> AL				
MISC: <input type="checkbox"/> MLO <input checked="" type="checkbox"/> BKR		MAIN AMP: 100 <input type="checkbox"/> MLO <input checked="" type="checkbox"/> BKR				
FED FROM:		FED FROM:				
KVA	USE	BKR No.	Phase No.	BKR No.	USE	KVA
--	RECEPTACLE	20/1	1 A	2 20/1	RECEPTACLE	--
		3 B	4			
		5 C	6			
		7 A	8			
		9 B	10			
		11 C	12			
		13 A	14			
		15 B	16			
		17 C	18			
		19 A	20			
		21 B	22			
	SPARE	23 C	24		SPARE	
		25 A	26			
		27 B	28			
		29 C	30			

LOAD KVA: .

MINIMUM AIC: 22,000		VOLTAGE: <input type="checkbox"/> 120/208 <input type="checkbox"/> 480/277 <input type="checkbox"/> 120/240				
TYPE: <input type="checkbox"/> FLUSH <input checked="" type="checkbox"/> SURFACE <input type="checkbox"/> FREESTANDING		PHASE: <input type="checkbox"/> 1-PHASE <input checked="" type="checkbox"/> 3-PHASE				
MOUNTING: <input type="checkbox"/> CU <input checked="" type="checkbox"/> AL		BUS AMP: 100 <input type="checkbox"/> CU <input checked="" type="checkbox"/> AL				
MISC: <input type="checkbox"/> MLO <input checked="" type="checkbox"/> BKR		MAIN AMP: 100 <input type="checkbox"/> MLO <input checked="" type="checkbox"/> BKR				
FED FROM:		FED FROM:				
KVA	USE	BKR No.	Phase No.	BKR No.	USE	KVA
--	RECEPTACLE	20/1	1 A	2 20/1	RECEPTACLE	--
		3 B	4			
		5 C	6			
		7 A	8			
		9 B	10			
		11 C	12			
		13 A	14			
		15 B	16			
		17 C	18			
		19 A	20			
		21 B	22			
	SPARE	23 C	24		SPARE	
		25 A	26			
		27 B	28			
		29 C	30	30/2	INH-2	6.3 *

LOAD KVA: .

* REMOVE 2-20/1 AND PROVIDE 1-30/2 WITH HARDWARE.

MINIMUM AIC: 22,000		VOLTAGE: <input type="checkbox"/> 120/208 <input type="checkbox"/> 480/277 <input type="checkbox"/> 120/240				
TYPE: <input type="checkbox"/> FLUSH <input checked="" type="checkbox"/> SURFACE <input type="checkbox"/> FREESTANDING		PHASE: <input type="checkbox"/> 1-PHASE <input checked="" type="checkbox"/> 3-PHASE				
MOUNTING: <input type="checkbox"/> CU <input checked="" type="checkbox"/> AL		BUS AMP: 100 <input type="checkbox"/> CU <input checked="" type="checkbox"/> AL				
MISC: <input type="checkbox"/> MLO <input checked="" type="checkbox"/> BKR		MAIN AMP: 100 <input type="checkbox"/> MLO <input checked="" type="checkbox"/> BKR				
FED FROM:		FED FROM:				
KVA	USE	BKR No.	Phase No.	BKR No.	USE	KVA
--	RECEPTACLE	20/1	1 A	2 20/1	RECEPTACLE	--
		3 B	4			
		5 C	6			
		7 A	8			
	SPARE	9 B	10		SPARE	
		11 C	12			
		13 A	14			
		15 B	16			
		17 C	18			
		19 A	20			
		21 B	22			
		23 C	24			
		25 A	26			
		27 B	28	30/2	INH-2	6.3 *
		29 C	30			

LOAD KVA: .

* REMOVE 2-20/1 AND PROVIDE 1-30/2 WITH HARDWARE.

MINIMUM AIC: 22,000		VOLTAGE: <input type="checkbox"/> 120/208 <input type="checkbox"/> 480/277 <input type="checkbox"/> 120/240				
TYPE: <input type="checkbox"/> FLUSH <input checked="" type="checkbox"/> SURFACE <input type="checkbox"/> FREESTANDING		PHASE: <input type="checkbox"/> 1-PHASE <input checked="" type="checkbox"/> 3-PHASE				
MOUNTING: <input type="checkbox"/> CU <input checked="" type="checkbox"/> AL		BUS AMP: 100 <input type="checkbox"/> CU <input checked="" type="checkbox"/> AL				
MISC: <input type="checkbox"/> MLO <input checked="" type="checkbox"/> BKR		MAIN AMP: 100 <input type="checkbox"/> MLO <input checked="" type="checkbox"/> BKR				
FED FROM:		FED FROM:				
KVA	USE	BKR No.	Phase No.	BKR No.	USE	KVA
--	RECEPTACLE	20/1	1 A	2 20/1	RECEPTACLE	--
		3 B	4			
		5 C	6			
		7 A	8			
		9 B	10			
		11 C	12			
		13 A	14			
		15 B	16			
		17 C	18			
		19 A	20			
		21 B	22			
		23 C	24			
		25 A	26		SPARE	
		27 B	28			
		29 C	30			

LOAD KVA: .

MINIMUM AIC: 22,000		VOLTAGE: <input type="checkbox"/> 120/208 <input type="checkbox"/> 480/277 <input type="checkbox"/> 120/240				
TYPE: <input type="checkbox"/> FLUSH <input checked="" type="checkbox"/> SURFACE <input type="checkbox"/> FREESTANDING		PHASE: <input type="checkbox"/> 1-PHASE <input checked="" type="checkbox"/> 3-PHASE				
MOUNTING: <input type="checkbox"/> CU <input checked="" type="checkbox"/> AL		BUS AMP: 100 <input type="checkbox"/> CU <input checked="" type="checkbox"/> AL				
MISC: <input type="checkbox"/> MLO <input checked="" type="checkbox"/> BKR		MAIN AMP: 100 <input type="checkbox"/> MLO <input checked="" type="checkbox"/> BKR				
FED FROM:		FED FROM:				
KVA	USE	BKR No.	Phase No.	BKR No.	USE	KVA
--	RECEPTACLE	20/1	1 A	2 20/1	RECEPTACLE	--
		3 B	4			
		5 C	6			
		7 A	8			
		9 B	10			
		11 C	12			
		13 A	14			
		15 B	16			
		17 C	18			
		19 A	20			
		21 B	22			
		23 C	24			
	SPARE	25 A	26		INH-2	6.3 *
		27 B	28			
		29 C	30	30/2		

LOAD KVA: .

* REMOVE 2-20/1 AND PROVIDE 1-30/2 WITH HARDWARE.

MINIMUM AIC: 22,000		VOLTAGE: <input type="checkbox"/> 120/208 <input type="checkbox"/> 480/277 <input type="checkbox"/> 120/240					
TYPE: <input type="checkbox"/> FLUSH <input checked="" type="checkbox"/> SURFACE <input type="checkbox"/> FREESTANDING		PHASE: <input type="checkbox"/> 1-PHASE <input checked="" type="checkbox"/> 3-PHASE					
MOUNTING: <input type="checkbox"/> CU <input checked="" type="checkbox"/> AL		BUS AMP: 100 <input type="checkbox"/> CU <input checked="" type="checkbox"/> AL					
MISC: <input type="checkbox"/> MLO <input checked="" type="checkbox"/> BKR		MAIN AMP: 100 <input type="checkbox"/> MLO <input checked="" type="checkbox"/> BKR					
FED FROM:		FED FROM:					
KVA	USE	BKR No.	Phase No.	BKR No.	USE	KVA	
--	RECEPTACLE	20/1	1 A	2 20/1	LIGHTING	--	
		3 B	4		SPARE		
		5 C	6				
		7 A	8		RECEPTACLE		
		9 B	10				
	(E) LOAD	11 C	12				
		13 A	14		(E) RECEPTACLES 8		
		15 B	16				
		17 C	18				
	SPARE	19 A	20				
--	(E) LOAD	50/3	21 B	22	50/3	(E) LOAD	--
		23 C	24				
		25 A	26				
--	(E) LOAD	20/2	27 B	28	20/2	(E) LOAD	--
		29 C	30	30/1			
		31 A	32		(E) SERVER		
		33 B	34		(E) RECEPTACLES 8		
		35 C	36				
		37 A	38				
		39 B	40	20/2	(E) SOLAR	--	

LOAD KVA: .

MINIMUM AIC: .		VOLTAGE: <input type="checkbox"/> 120/208 <input type="checkbox"/> 480/277 <input type="checkbox"/> 120/240				
TYPE: <input type="checkbox"/> FLUSH <input checked="" type="checkbox"/> SURFACE <input type="checkbox"/> FREESTANDING		PHASE: <input type="checkbox"/> 1-PHASE <input checked="" type="checkbox"/> 3-PHASE				
MOUNTING: <input type="checkbox"/> CU <input checked="" type="checkbox"/> AL		BUS AMP: 600 <input type="checkbox"/> CU <input checked="" type="checkbox"/> AL				
MISC: <input type="checkbox"/> MLO <input checked="" type="checkbox"/> BKR		MAIN AMP: 600 <input type="checkbox"/> MLO <input checked="" type="checkbox"/> BKR				
FED FROM:		FED FROM:				
KVA	USE	BKR No.	Phase No.	BKR No.	USE	KVA
--	SPACE	3P	1 A	2	SPACE	--
			3 B	4		
			5 C	6		
			7 A	8		
			9 B	10		
			11 C	12</		

ONE INCH = TWENTY FEET
 ONE-SIXTEENTH INCH = ONE FOOT
 ONE-EIGHTH INCH = ONE FOOT
 ONE-FOURTH INCH = ONE FOOT
 ONE-HALF INCH = ONE FOOT
 THREE-QUARTERS INCH = ONE FOOT
 ONE INCH = ONE FOOT
 ONE AND ONE-HALF INCH = ONE FOOT

EXHAUST FAN SCHEDULE

DESIG.	UNIT TYPE	VOLT / φ	MOTOR	
			HP	WATTS
REF 1	ROOF EXHAUST FAN	120V/1φ	1/4	-
REF 2			1/4	-
REF 3			1/4	-
REF 4			1/4	-
REF 5			1/4	-
REF 6			1/4	-
REF 7			1/4	-
REF 8			1/4	-
REF 9			1/4	-
REF 10			1/4	-
REF 11			1/4	-
REF 12			1/4	-
REF 13			1/8	-
CEP 1	CEILING EXHAUST FAN	120V/1φ	-	224
CEP 2			-	224
CEP 3			-	224
CEP 4			-	129
EF 1	EXHAUST FAN	120V/1φ	3/4	-
EF 2			3/4	-

MISC. EQUIPMENT SCHEDULE

MH 1	INSTANTANEOUS WATER HEATER-1 8 KW, 38 AMPS, 208V/1φ
MH 2	INSTANTANEOUS WATER HEATER-2 6.24 KW, 30 AMPS, 208V/1φ

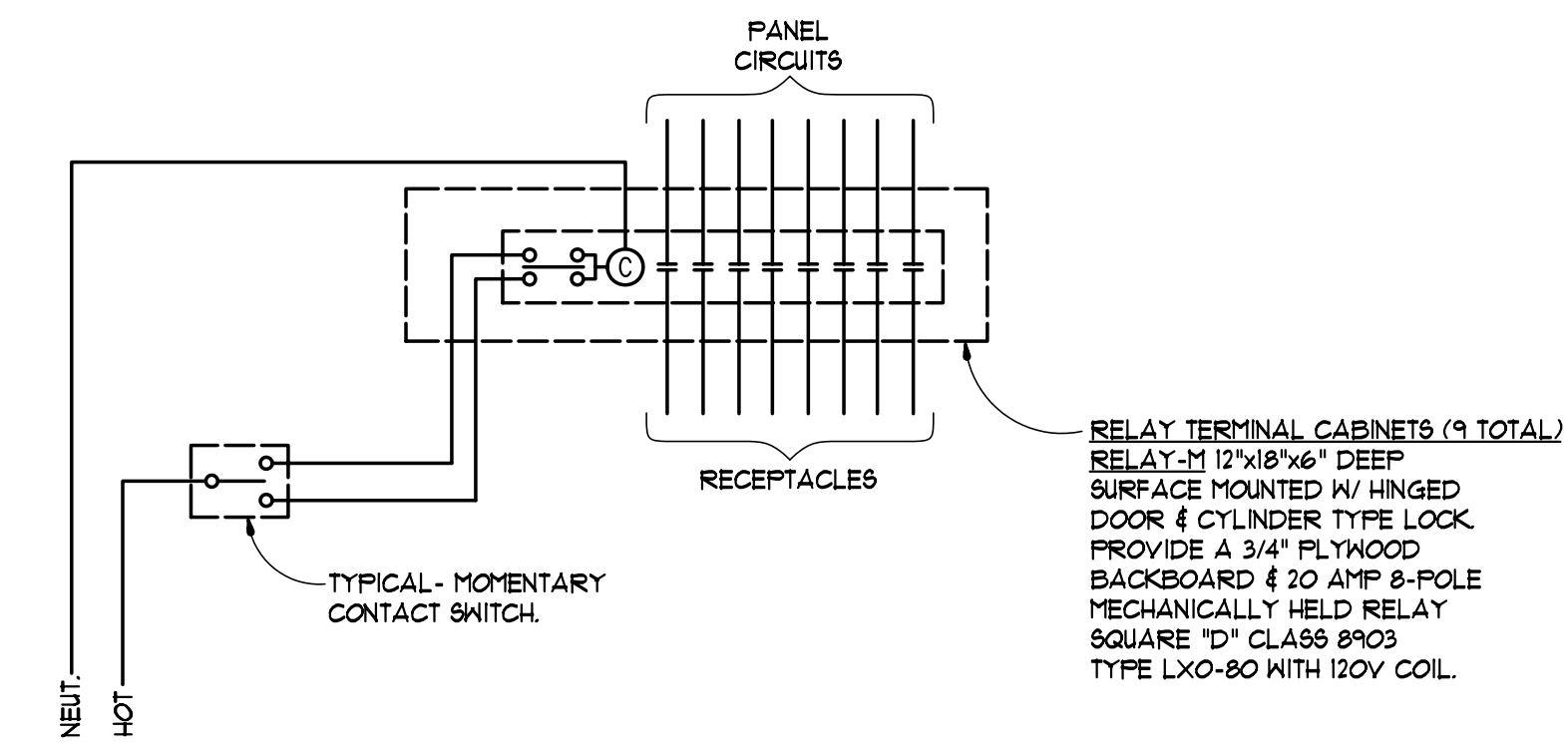

A RECEPTACLE WIRING DIAGRAM
 E7.2 NO SCALE

**Mt. Diablo High School
 Building S - Science Lab Modernization**

2450 Grant Street
 Concord, California 94520

Mt. Diablo Unified School District



FILE NO. xx-xx
 IDENTIFICATION STAMP
 DIV. OF THE STATE ARCHITECT
 OFFICE OF REGULATION SERVICES

APPLICATION NO.
 01-

AC. FLS. SS

DATE

DIVISION OF THE STATE ARCHITECT
 revision date: by:

HARRY A YEE & ASSOCIATES, INC.
 ELECTRICAL ENGINEERS
 4920 FREEMONT BLVD., SUITE D
 SACRAMENTO, CALIFORNIA 95822
 TEL: 916.454.5319
 FAX: 916.454.4117
 HYA job #1251

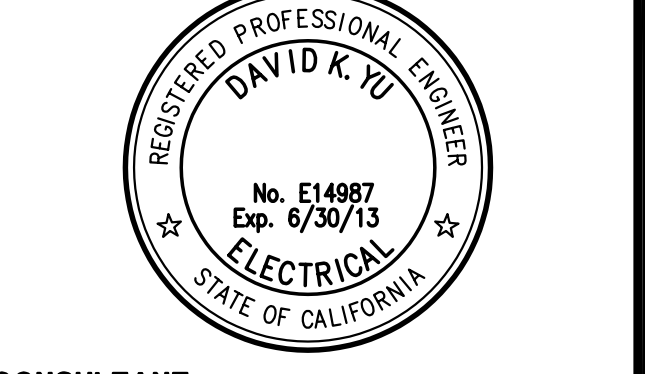

CONSULTANT

nacht&lewis

600 O Street, Suite 100
 Sacramento, CA 95811
 www.nachtlewis.com
 916.329.4000

ARCHITECT

REVISIONS			
NO.	DESCRIPTION	DATE	REV'D

DATE February 19, 2013
 JOB NO. Y1211.00
 SHEET TITLE

**Mechanical
 Equipment
 Schedules**

SHEET NO.
E7.2
 SHEET ___ OF ___ TOTAL
 DSA SUBMITTAL SET



Mt. Diablo Unified School District LLB #1617

ADDENDUM NO. 1617-001

PROJECT: Lease/Leaseback #1617
OWNER: Mt. Diablo Unified School District
3333 Ronald Way
Concord, CA 94519

DATE: 05-08-13

DSA APP. NO.: 01-113151
DSA File. NO.: 7-H5
NLA FILE NO.: Y121L00

Submission Opening CHANGED: May 15, 2013, 2:00 P.M.

Notice is hereby given to all prospective bidders that plans and specifications on the subject project are modified as herein set forth. This Addendum shall be attached to and form a part of the plans and specifications. All bidders must acknowledge receipt of this addendum on the Bid Form.

It is the responsibility of all bidders to notify all subcontractors from whom they request bids and from whom they accept bids of all changes contained in this addendum.

GENERAL ANNOUNCEMENTS

The enclosed documents provide clarification or additional responsibilities on the part of the firm.

Review enclosed modifications to bid documents as a result of comments or clarifications made subsequent to the release of this bid.

Add DSA Application to all pages (where applicable)

DOCUMENT CHANGES

RFQ/RFP CHANGES

1. **DOCUMENT ADDITION/CHANGES:**
 - a. **CHANGE** document to reflect revised response to May 15, 2013.
 - b. **CHANGE** Paragraph I.B to: "Proposal. In addition, the Firms shall provide a firm proposal to the District to perform the Project as indicated herein. The Firm selected as a result of this process may thereafter work cooperatively with the District Board, staff and consultants, the design team (if any), and the Project inspectors, to facilitate the timely completion of the Project."
 - c. **CHANGE** Attachment "A" Paragraph 1 to read: "**The District has estimated that the Project's construction budget (hard costs) is between \$2 million and 2.5 million, which already includes a contingency and escalation.**"
 - d. **CHANGE** Attachment "A" Paragraph 2 to read: "**This Project, including equipment, occupancy and punch-list must be fully completed by January 10, 2014.**"

ATTACHMENT "B" CHANGES

1. **DOCUMENT ADDITION/CHANGES:**

- a. **REPLACE: EXHIBIT H – AGREEMENT FOR PRELIMINARY SERVICES with attached (9 pages).**

ATTACHMENT “C” CHANGES

2. **DOCUMENT ADDITION/CHANGES:**
a. **None**

ATTACHMENT “D” CHANGES

3. **DRAWING ADDITION/CHANGES/DELETIONS:**
None

REQUESTS FOR INFORMATION / CLARIFICATIONS:

	Question/Clarification(Section)	Response
1.	What is the process for submitting substitutions/equals?	As identified in the contact documents, any and all variance from listed items identified in the project documents must be addressed prior to bid opening. The following items have been reviewed for substitution and/or equal with restrictions noted: NONE
2.	What are the access limitations?	The contractor shall proceed accordingly and shall schedule all deliveries and arrivals to meet the requirements of the site. Any deviation from this requirement will be addressed in writing, prior to occurrences.
7.	When are custodial services required?	Custodial services are required any time the contractor must enter any District building. If the contractor is limiting operations to exterior locations, there will be no need for custodial services. There will be no additional charges during periods “normally” covered by a custodian on-site.
8.	What are custodial hours?	Typical custodial hours are 7:00 am to 11:00 PM. Spring Break/Summer custodial hours are 7:00 am to 3:30 p.m.; the district custodian shall secure campus daily. This procedure must be completed by 3:30. Without prior authorization, the contractor shall clear interior locations and not delay the completion of custodial requirement.
9.	Available Utilities	While utilities may be available, any cost associated with temporary connections and/or other costs will remain the responsibility of the contractor (i.e. meters, temporary power poles)
10a.	Proposal & Construction Requirements:	District reserves the right to enter into either a PSA (Exhibit H) or Lease Agreement. Additionally, the District reserves the right to review all estimates prior to recommending/executing lease documents.
10b.		Refer to attached General Electrical Requirements document for FA, Clock, IC, and data. All these electrical components shall be included in these contracts.
10c.		The general contractor is required to verify in field actual existing exposed condition and extent of demolition and construction required to perform job prior to bid - not all existing conditions are shown

		on the drawings.
10d.		In addition the general contractor must walk each site to verify the scope of work shown on the drawings and note to the district any discrepancy or conflict.
10e.		It is understood that these approved drawings are showing the intent of the scope of work and assumptions have been made. Contingency for removal/re-routing, re-constructing, re-sizing existing exterior utility lines such as (but not limited to) gas, sewer, water, clean-outs., storm drains & catch basins, sprinkler systems, electrical & data boxes and related cables & conduits (concealed and not) must be included on the base bid.
10f.		With the above the general contractor is advised and agrees that the district will not negotiate additional compensations on items not shown on the drawings but, visible and/or exposed and reasonably assumed from the project scope and obviously required to be performed in order to attain a complete and finished product.
10g.		The district assumes that the general contractor has performed a detailed site/job evaluation as described above, prior to bid issuance.
10h.		The general contractor to ensure the following: 1. Per the new district standard, each classroom shall receive (6) data drops + (1) wireless. 2. Prep. Room will need (2) data drops. 3. Each work station in science and chemistry classroom shall have (6) duplex receptacles. 4. Provide (4) duplex receptacles in each teacher's work station and space equally.
10i.		Work anticipated WILL BE phased. The general contractor to ensure general conditions necessary to maintain safety and protection during hours of operation OR install exterior doors early and utilize as access to project.
11.	AND NO OTHERS	

END OF ADDENDUM NO. 1617-001

EXHIBIT H
AGREEMENT FOR PRELIMINARY SERVICES
BETWEEN
MT. DIABLO UNIFIED SCHOOL DISTRICT AND

FOR
MT. DIABLO HIGH SCHOOL
S-Wing Modernization

This Agreement for Preliminary Services ("Agreement") dated as of _____, 2013 ("Effective Date"), is made and entered into by and between the Mt. Diablo Unified School District, a school district duly organized and validly existing under the laws of the State of California ("District"), and _____, a California company duly organized and existing under the laws of the State of California, as lessee ("Developer") (together, the "Parties"), for the purposes of providing preliminary services relating to the construction of the S-Wing Modernization - Mt. Diablo High School located at 2450 Grant Street, Concord, CA 9 ("Project").

WHEREAS, the Project will be located at 2450 Grant Street, Concord, CA 94520 as more particularly described in **Attachment "B,"** attached hereto and incorporated herein by this reference ("Site"); and

WHEREAS, District and Developer intend to enter into a lease-leaseback arrangement for the development of the Project pursuant to Education Code section 17406 ("Lease Agreements") after Developer's performance of its duties as set forth in the Agreement and pending both the approval of the Plans and Specifications by the California Division of State Architect ("DSA") and approval by the District and Developer of the Lease Agreements.

WHEREAS, Developer desires to provide consulting services to the District with respect to other related services in preparation for the Project's development; and

WHEREAS, the District is authorized by Section 53060 of the California Government Code to contract with and employ any persons for the furnishing of special services and advice in financial, economic, accounting, engineering, legal or administrative matters, if those persons are specially trained and experienced and competent to perform the special services required; and

WHEREAS, Developer represents that it is specially trained and has the expertise and experience to perform the services set forth in this Agreement; and

NOW, THEREFORE, the Parties hereto agree as follows:

ARTICLE 1. SCOPE OF SERVICES

Scope of Developer's Services. Developer, as the District's development consultant and authorized representative as contemplated by Business and Professions Code Section 7040, agrees to perform the services indicated in **Attachment "A,"** attached hereto and incorporated herein by this reference ("Services"). In providing the Services pursuant to this Agreement, Developer does not assume any responsibility for design, design errors, omissions or inconsistencies. The duties, responsibilities and limitations of authority of Developer shall not be restricted, modified or extended without written agreement between the District and Developer

ARTICLE 2. CONSTRUCTION

The Parties expect to enter into the Lease Agreements on or about _____, 2013. The Parties expect that the Project shall be completed on or before _____, 2014.

ARTICLE 3. DISTRICT'S RESPONSIBILITIES

The District shall provide to Developer information regarding requirements for the Project, including information regarding the District's objectives, schedule, constraints and criteria.

ARTICLE 4. TERM & TERMINATION

4.1. Term. The term of this Agreement ("Term") shall be 2 months from the date indicated above as the date of this Agreement. The Term may be shortened or lengthened by mutual agreement of the Parties or terminated as indicated herein.

4.2. Termination by Developer. This Agreement may be terminated by Developer upon fourteen (14) days written notice to District in the event of an uncured substantial failure of performance by District.

4.3. Termination by District. This Agreement may be terminated without cause by District upon fourteen (14) days written notice to Developer. In the event of a termination by District, the District shall pay Developer for all Services performed and all expenses incurred under this Agreement up until the date of notice of termination plus any sums due Developer for Board approved extra services. In ascertaining the Services actually rendered hereunder up to the date of termination of this Agreement, consideration shall be given to both completed work and work in process of completion and to complete and incomplete documents whether delivered to the District or in the possession of Developer.

ARTICLE 5. COMPENSATION TO DEVELOPER

District agrees to pay Developer the amount of _____ Dollars (\$ _____ .00), for the performance of the Services contemplated by this Agreement, as indicated in **Attachment "C" ("Services: Costs & Schedule")**. Developer shall be responsible for all costs and expenses including the costs of hiring sub-consultants and other professionals to perform the Services, travel expenses to the Project site as well as for meetings with District and its representatives, long distance telephone charges, copying expenses, salaries of Developer's staff and employees working on the Project, overhead, and any other reasonable expenses incurred by Developer in performance of the Services contemplated by this Agreement. Developer shall submit the names of all proposed sub-consultants to District in writing for the District's prior approval.

ARTICLE 6. MISCELLANEOUS

6.1. Developer's Insurance. Developer has in force, and during the term of this Agreement shall maintain in force with the minimum indicated limits, the following insurance: **Commercial General Liability insurance:** \$1,000,000 for each occurrence and general aggregate with Products and Completed Operations Coverage; **Automobile Liability – Any Auto:** combined single limit of \$1,000,000; **Excess Liability insurance:** \$4,000,000; **Workers Compensation:** Statutory limits; **Employers' Liability:** \$1,000,000; and **Professional Liability (Errors and Omissions):** \$1,000,000. Developer shall provide to the District certificate(s) of insurance and endorsements satisfactory to the District. The policy(ies) shall not be amended or modified and the coverage amounts shall not be reduced without thirty (30) days written notice to the District prior to cancellation. Except for the worker's compensation and professional liability insurance policies, the District shall be named as an additional insured on all policies. Developer's policy(ies) shall be primary; any insurance carried by the District shall only be secondary and supplemental. All policies, except for professional liability, shall be written on an occurrence form. Developer shall not allow any subconsultant, subcontractor, employee, or agent to commence work on this Agreement or any subcontract until the insurance required of Developer, subcontractor, or agent has been obtained.

6.2. Indemnity. To the furthest extent permitted by California law, Developer shall defend, indemnify, and hold free and harmless the District, its agents, representatives, officers, consultants, employees, trustees, and volunteers ("the indemnified parties") from any and all claims, demands, causes of action, costs, expenses, liability,

loss, damage or injury of any kind, in law or equity ("Claim"), to property or persons, including personal injury and/or death, to the extent that any of the above arise out of, pertain to, or relate to the negligence, recklessness, errors or omissions, or willful misconduct of Developer, its officials, officers, employees, subcontractors, consultants, or agents directly or indirectly arising out of, connected with, or resulting from the performance of the Services, the Project, or this Agreement

6.3. Independent Contractor. Developer, in the performance of this Agreement, shall be and act as an independent contractor. Developer understands and agrees that Developer and all of Developer's employees shall not be considered officers, employees or agents of the District.

6.4. Audit. Developer shall establish and maintain books, records, and systems of account, in accordance with generally accepted accounting principles, reflecting all business operations of Developer transacted under this Agreement. Developer shall retain these books, records, and systems of account during the Term of this Agreement and for five (5) years thereafter. Developer shall permit the District, its agent, other representatives, or an independent auditor to audit, examine, and make excerpts, copies, and transcripts from all books and records, and to make audit(s) of all billing statements, invoices, records, and other data related to the Services covered by this Agreement. Audit(s) may be performed at any time, provided that the District shall give reasonable prior notice to Developer and shall conduct audit(s) during Developer's normal business hours, unless Developer otherwise consents.

6.5. Confidentiality. Developer and all Developer's agents, personnel, employee(s), and/or subcontractor(s) shall maintain the confidentiality of all information received in the course of performing the Services. This requirement to maintain confidentiality shall extend beyond the termination of this Agreement.

6.6. Standard of Care. Developer shall remain liable to the District in accordance with this Agreement for all damages to the District caused by Developer's failure to perform any of the Services furnished under this Agreement to the standard of care of Developer for its Services, which shall be, at a minimum, the standard of care of a construction managers performing similar work for California school districts at or around the same time and in or around the same geographic area of the District.

6.7. No Third Party Rights. Nothing contained in this Agreement shall create a contractual relationship with or a cause of action in favor of any third party against either the District or Developer.

6.8. Binding on Successors. The District and Developer, respectively, bind themselves, their partners, officers, successors, assigns and legal representatives to the other party to this Agreement with respect to the terms of this Agreement. Developer shall not assign this Agreement.

6.9. Governing Law. This Agreement shall be governed by the laws of the State of California. The Parties further agree that any action or proceeding brought to enforce the terms and conditions of this Agreement shall be maintained and venued in the county where the District's administrative offices are located.

6.10. Modifications. This Agreement represents the entire Agreement between the District and Developer and supersedes all prior negotiations, representations or agreements, either written or oral. This Agreement may be amended or modified only by an agreement in writing signed by both the District and Developer.

6.11. Lease Agreements. In no event shall either party be obligated to enter into the Lease Agreements. District reserves the right to enter into the Lease Agreements with parties other than Developer. District shall not be responsible to Developer for any claims or damages resulting from District's failure to enter into the Lease Agreements with Developer.

ACCEPTED AND AGREED on the date indicated below:

Dated: _____, 20____

Dated: _____, 20____

Mt. Diablo Unified School District

By: _____

By: _____

Print Name: _____

Print Name: _____

Print Title: Superintendent

Print Title: _____

DRAFT

Attachment "A"**Scope of Services**

Developer shall perform management and coordination services, plan and specification constructability reviews, provide value-engineering reviews and recommendations and other reviews as necessary to verify that the drawings and specifications are clear and reasonably accurate to minimize the need for changes during the construction phase of the project, including but not limited to the following:

A. General Services.

- 1 Developer shall attend regular meetings during project development between the Architect, the District, District site personnel, and any other applicable consultants of the District as required to discuss the Project, including budget, scope and schedule.
- 2 Developer shall assist Architect with the making of a written record of all meetings, conferences, discussions and decisions made between or among the District, Architect and Developer.
- 3 Developer shall assist the Architect with making formal presentations to the governing board of District.
- 4 Developer shall prepare and update the preliminary Project schedule.
- 5 Developer shall prepare and update the components of the Guaranteed Project Cost and shall be primarily in control of ensuring that the Project can and is constructed for no more than that amount.
- 6 Assist District with City land use issues;
- 7 Assist District with DSA review, input, and timeframe for same;
- 8 Provide review and comment upon survey of the Project site;
- 9 Provide review and comment upon any EIR or other required CEQA documents with District's CEQA consultant.

B. Review of Design Documents.

- 1 Review Project design and budget with the District and the Architect during the Schematic Design Phase, the Design Development Phase, at 50% Construction Documents Phase, and at 100% Construction Documents Phase to:
 - a. Provide recommendations on site use and improvements, selection of materials, building systems and equipment and methods of Project delivery;
 - b. Provide recommendations on relative feasibility of construction methods, availability of materials and labor, time requirements for procurement, installation and construction of the Project and subparts thereof if requested, and factors relating to cost including, but not limited to, construction costs of alternate designs of materials, preliminary budgets and possible economics that could be achieved through alternate methods or substitutions;
 - c. Provide interim design phase estimates to establish and maintain the Project budget and scheduled costs; and
 - d. Provide plan review.

e. Value-engineering. Prepare a value-engineering report for District review and approval that:

- (1) Details areas of cost saving (e.g. construction processes/procedures, specified materials and equipment, and equipment or other aspects of the design documents that can be modified to reduce costs and/or the time for achieving final completion of the Project and/or to extend life-cycle and/or to reduce maintenance/operations costs, without diminution in the quality of materials/equipment/workmanship, scope or intended purposes of the Project);
- (2) Provides detailed estimate for proposed value-engineering items;
- (3) Defines methodology or approaches that maximize value; and
- (4) Identifies design choices that can be more economically delivered.

f. Constructability Review. Prepare detailed interdisciplinary constructability review within thirty (30) days of receipt of the plans from the District that:

- (1) Ensures construction documents are well coordinated and reviewed for errors;
- (2) Identifies to the extent known, construction deficiencies and areas of concern;
- (3) Back-checks design drawings for inclusion of modifications;
- (4) Provides the District with written confirmation that:
 - (a) Requirements noted in the design documents prepared for the Project are consistent with and conform to the District's Project requirements and design standards.
 - (b) Various components have been coordinated and are consistent with each other so as to minimize conflicts within or between components of the design documents.

2. Confirm Modifications to Design Drawings. If the District accepts Developer's comments, including the value-engineering and/or constructability review comments, review the design documents to confirm that those comments are properly incorporated into the final design documents.

C. Budget of Project Costs.

1. At each stage of plan review indicated above, Developer will update and refine the budget of the Guaranteed Project Cost based on the most recent set of design documents. Developer shall also advise the District and the Architect if it appears that the total construction costs may exceed the Guaranteed Project Cost established by the District and shall make recommendations for corrective action. Developer will further provide input to the District and Architect relative to value of construction, means and methods for construction, duration of construction of various building methods and constructability.
2. In each budget of the Guaranteed Project Cost, Developer shall include values of scopes of work subdivided into component parts in sufficient detail to serve as the basis for progress payments during construction. This budget of the Guaranteed Project Cost shall include, at a minimum, the following information divided into at least the following categories:
 - a. Overhead and profit;
 - b. Supervision;
 - c. General conditions;
 - d. Layout & Mobilization (not more than 1%)
 - e. Submittals, samples, shop drawings (not more than 3%);
 - f. Bonds and insurance (not more than 2%);
 - g. Close-out documentation (not less than 3%);
 - h. Demolition;
 - i. Installation;
 - j. Rough-in;

- k. Finishes;
- l. Testing;
- m. Punchlist and acceptance.

- 3 Developer shall indicate its willingness and ability to enter into the Lease Agreements to construct the Project for at or below that Guaranteed Project Cost, excluding unforeseen conditions or District-requested changes. This commitment will be a component of the Lease Agreements.

D. Construction Schedule and Phasing Plan.

Developer shall prepare a preconstruction schedule to guide the design team through to bid dates. That schedule shall show the multiphases and interrelations of design, constructability review, and estimating. Developer shall also prepare a full construction schedule for the Project detailing the phasing and construction activities. Developer shall further investigate, recommend and prepare a schedule for the District's purchase of materials and equipment requiring long lead time procurement, and coordinate the schedule with the early preparation of portions of the Contract Documents by the Architect.

E. Construction Planning and Bidding.

- 1 Prepare and distribute specifications and drawings provided by District to facilitate bidding to Developer's subcontractors.
- 2 Review the drawings and specifications to eliminate areas of conflict and overlapping in the work to be performed by various subcontractors, and with a view to eliminating change order requests by the Architect or subcontractors.
- 3 Conduct pre-bid conferences. Coordinate with District and the Architect in responding to subcontractor questions or providing clarification to all subcontractors.
- 4 At or around DSA approval (estimated to be **June 6, 2013**), receive subcontractor bids and develop the final GPC in accordance with the lease-leaseback agreement forms, including the requirement that the Developer receive at least three (3) to seven (7) bona fide bids from subcontractors for all scopes of work on the Project that constitute more than three percent (3%) of the total GPC (Article 7 of Attachment D to the Facilities Lease).

Attachment "C"
Services: Costs & Schedule

DRAFT



Mt. Diablo Unified School District LLB #1617

ADDENDUM NO. 1617-002

PROJECT: Lease/Leaseback #1617
OWNER: Mt. Diablo Unified School District
3333 Ronald Way
Concord, CA 94519

DATE: 05-10-13

DSA APP. NO.: 01-113151
DSA File. NO.: 7-H5
NLA FILE NO.: Y121L00

Submission Opening REMAINS: May 15, 2013, 2:00 P.M.

Notice is hereby given to all prospective bidders that plans and specifications on the subject project are modified as herein set forth. This Addendum shall be attached to and form a part of the plans and specifications. All bidders must acknowledge receipt of this addendum on the Bid Form.

It is the responsibility of all bidders to notify all subcontractors from whom they request bids and from whom they accept bids of all changes contained in this addendum.

GENERAL ANNOUNCEMENTS

The enclosed documents provide clarification or additional responsibilities on the part of the firm.

Review enclosed modifications to bid documents as a result of comments or clarifications made subsequent to the release of this bid.

Add DSA Application to all pages (where applicable)

DOCUMENT CHANGES

RFQ/RFP CHANGES

1. **DOCUMENT ADDITION/CHANGES:**
 - a. **CHANGE** Paragraph E.1 to read: "The District intends to first enter into a PSA with the successful firm(s) to partner with the District's staff, Program Manager and Architect to provide preconstruction services that will lead to the Firm providing to the District a Guaranteed Maximum Price (GMP) for the project. The scope of Preconstruction Services will generally consist of reviewing existing documents and site conditions, scheduling, estimating, constructability review, subcontractor bidding, and development of the GMP, as described fully in the Preconstruction services agreement (Exhibit B/Attachment H). The District will require an open-book policy with the Firm and its construction team. Additionally, District will require the selected contractor to submit a copy of all subcontractor bids, pricing backup, contingency breakdown and tracking, general conditions breakdown and tracking, and Firm fees upon submission of the GMP and as indicated herein."
 - b. **CHANGE** Paragraph G to read: "**Provide your Firm's anticipated charges to the District for the following items:**"
 - c. **DELETE** Paragraph G.7

ATTACHMENT “B” CHANGES

- 1. DOCUMENT ADDITION/CHANGES:
 - a. NONE.

ATTACHMENT “C” CHANGES

- 2. DOCUMENT ADDITION/CHANGES:
 - a. None

ATTACHMENT “D” CHANGES

- 3. DRAWING ADDITION/CHANGES/DELETIONS:
 - a. CHANGE A3.0 to reflect provide and install (3) 72”X30”X30” Student tables with epoxy resin tops, solid hardwood construction with legs thru bolted to table body – As manufactured by Sheldon Laboratory Systems (www.sheldonlabs.com). Delete previously indicated fixed architectural casework in this area only to accommodate loose student tables. All other work, including electrical and data distribution in this are remains unchanged.
 - 1. Sketch attached

REQUESTS FOR INFORMATION / CLARIFICATIONS:

	Question/Clarification(Section)	Response
1.	Is a full proposal required to be submitted during with the qualification package?	District intends to enter into a PSA with the successful firm. In accordance with changes noted in this addendum and prior to executing lease agreement, District will work with Firm to establish a GMP.
11.	AND NO OTHERS	

END OF ADDENDUM NO. 1617-002

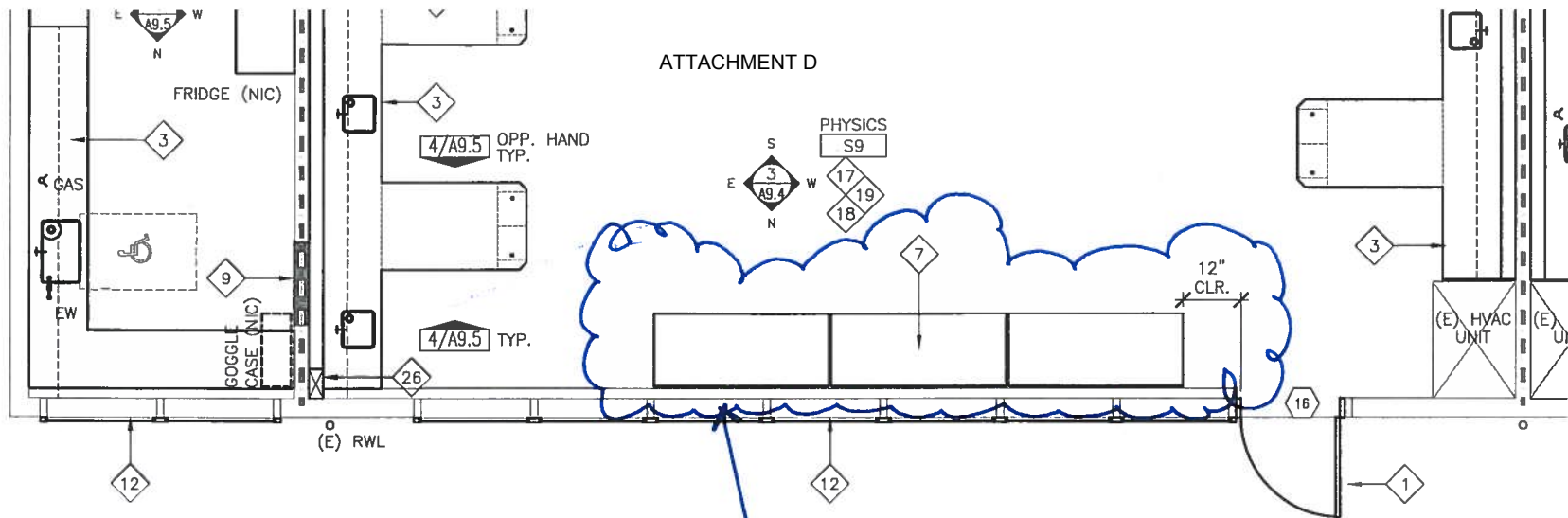

ATTACHMENT D

1 Partial Floor Plan - East
SCALE: 1/4" = 1'-0"

IN LIEU OF FIXED WIG CASEWORK SHOWN ON ORIGINAL PLANS, PROVIDE (3) LOOSE TABLES AS FOLLOWS:
72" x 30" x 30" STUDENT TABLES W/ EPOXY RESIN TOPS, SOLID HARDWOOD CONSTRUCTION WITH LEGS THRU-BOLTED TO TABLE BODY - AS MFR'D. BY SHELDON LAB. SYSTEMS - WWW.SHELDONLABS.COM

NEW WORK KEYNOTES:

THESE NEW WORK KEYNOTES APPLY TO THIS SHEET ONLY

- 1 NEW DOOR IN EXTERIOR WINDOW WALL - SEE OPENING SCHEDULE FOR DETAIL REFERENCES.
- 2 NEW DOOR IN INTERIOR WALL - SEE OPENING SCHEDULE FOR DETAIL REFERENCES.
- 3 PLASTIC LAMINATE BASE CABINETS WITH CHEMICAL/HEAT RESISTANT RESIN COUNTERTOPS.
- 4 SALVAGED AND REFINISHED UPPER WALL CABINETS - SEE INTERIOR ELEVATIONS.
- 5 INSTRUCTOR'S DEMONSTRATION TABLE WITH CHEMICAL/HEAT RESISTANT COUNTERTOP & SINK.
- 6 PLASTIC LAMINATE OPEN SHELVING UNIT WITH ADJUSTABLE SHELVES - SEE INTERIOR ELEVATIONS.
- 7 NEW STUDENT TABLES X 3. SEE SPEC SECTION 10 00 00.

- 12 NEW ALUMINUM EXTERIOR WINDOW SYSTEM WITH TYPICAL FINISHES AND GLAZING - TYPICAL ALL EXTERIOR WINDOWS EXCEPT MAIN HALLWAY ENTRY DOORS (3 LOCATIONS) SEE EXTERIOR ELEVATIONS.
- 13 NEW PASS-THRU DEMONSTRATION FUME HOOD.
- 14 PLASTIC LAMINATE BASE CABINET, COUNTERTOP & UPPER WALL CABINETS.
- 15 ROOM GAS SHUT OFF VALVE IN LOCKABLE WALL BOX - SEE PLUMBING DRAWINGS.
- 16 NEW MARKERBOARD & PROJECTION SCREEN.
- 17 NEW BBT RESILIENT FLOORING & RESILIENT BASE.
- 18 PATCH & REPAIR ALL WALL SURFACES, PROVIDE NEW TACKABLE VINYL WALL PANEL WAINSCOT AND PAINT BALANCE OF EXPOSED WALL SURFACES - SEE INTERIOR ELEVATIONS.
- 19 NEW 12"x12" ACOUSTICAL TILE CEILING ON EXISTING FURRING SEE REFLECTED CEILING PLANS..
- 20 AT NEW EPOXY WORKING SURFACE PROVIDE AT INSTI
- 21 (N) 1/4" CLEAR
- 22 (N) UTILITY CHAS
- 23 (N) UTILITY CHAS
- 24 INSTALL (N) PAPE OF DISPENSER O
- 25 RELOCATED SOAP OF DISPENSER O
- 26 REINSTALL (E) ST
- 27 PATCH & REPAIR AT RELOCATED P,

REFERENCE SHEET A3.0